



## STABILITY IN MULTI-DOMAIN BATTLE

---

COL Stephen Marr  
Lead Author



**PKSOI Paper**

**Stability in Multi-Domain Battle**

**U.S. Army Peacekeeping and Stability  
Operations Institute**

**June 2018**

**COL Stephen Marr  
Lead Author**

The views expressed in this report are those of the authors and do not necessarily reflect the official policy or position of the Department of the Army, the Department of Defense, or the U.S. Government. Authors of Peacekeeping and Stability Operations Institute (PKSOI) publications enjoy full academic freedom, provided they do not disclose classified information, jeopardize operations security, or misrepresent official U.S. policy. Such academic freedom empowers them to offer new and sometimes controversial perspectives in the interest of furthering debate on key issues. This report is cleared for public release; distribution is unlimited.

\*\*\*\*\*

This publication is subject to Title 17, United States Code, Sections 101 and 105. It is in the public domain and may not be copyrighted.

\*\*\*\*\*

Comments pertaining to this report are invited and should be forwarded to: Director, Peacekeeping and Stability Operations Institute, U.S. Army War College, 22 Ashburn Drive, Carlisle, PA 17013-5054.

\*\*\*\*\*

All Peacekeeping and Stability Operations Institute (PKSOI) publications are available on the PKSOI homepage for electronic dissemination. Hard copies of this report also may be ordered while copies last from our homepage. PKSOI's homepage address is: <http://pksoi.armywarcollege.edu>

\*\*\*\*\*

The Peacekeeping and Stability Operations Institute publishes a quarterly journal to update the peace and stability operations community on the research of our analysts, recent and forthcoming publications and upcoming conferences sponsored by PKSOI. Each quarterly journal has a specific theme related to peace and stability operations and a commentary by the Director of PKSOI entitled *The Director's Corner*. If you are interested in receiving this journal, please subscribe on our homepage at <http://pksoi.armywarcollege.edu/index.cfm/pksoi-publications-subscription/>

ISBN-13: 978-0-9981473-9-0

## FOREWORD

Stability is a fundamental component of Multi-Domain Battle (MDB). Integrating stability activities with MDB provides the entire Joint Force with increased decision space and expands freedom of operation. Stability actions during competition build partner capability, capacity, and resilience; identify and counter adversary destabilization efforts; and support deterrence. Stability actions during armed conflict increase the options for the application of all instruments of national power and protect the legitimacy of the United States Government (USG) integrated campaign. Finally, stability actions following armed combat prevent an adversary from reversing friendly gains, reestablish civilian control, and enable a sustainable future. Stability is the common thread that weaves Multi-Domain Battle, the Joint Concept for Integrated Campaigning (JCIC), and our national strategic documents together.

For MDB to succeed, the author recommends that the Army must be able to positively affect the five stability sectors, both directly and through integration with the Joint Force and inter-organizational partners, while also developing effective strategies to preempt or counter adversary destabilization efforts. MDB must be adapted to address threats below the level of armed conflict with a peer competitor with the objective of preventing competition from escalating to armed conflict through proactive stabilization and counter-destabilization efforts. The Army must reconsider its approach to stability within the multi-domain context: Protecting the legitimacy of the USG integrated campaign plan will be critical. The Army must also understand, plan, and account for second and third order impacts of military operations on

stability in order to enable the effective application of all elements of national power. Proactive stabilization, when combined with counter-destabilization efforts, works when diplomatic, development, and defense actors conduct deliberate coordination and planning, develop shared understanding, and develop common priorities.

The author further highlights the following questions as needing to be understood in order to fully integrating stability into MDB. How do Army forces support State Department efforts during competition, while also enabling the USG to more effectively converge diplomatic, informational, and economic forms of power during cooperation, competition, and armed conflict? How do forward deployed or expeditionary Army forces recognize non-military adversary competition activities? How does the Army achieve military objectives throughout the competition continuum while simultaneously preserving or increasing the options to employ other elements of national power that will be required for a sustainable political outcome? The author proposes solutions to each of these questions in the course of the paper.

Michael W. Rauhut  
Colonel, Infantry  
Director, U.S. Army Peacekeeping and Stability  
Operations Institute

## ABOUT THE AUTHORS

### **Lead Author**

COL Stephen Marr currently serves as the Governance Chief at the U.S. Army Peacekeeping and Stability Operations Institute. Commissioned as an Armor Officer in 1995, COL Marr has held numerous command and staff positions over the last 23 years highlighted by commanding the 4th Squadron, 10th U.S. Cavalry at Fort Carson and serving as the Operations Officer for the 4th Infantry Division and Special Operations Command North. COL Marr has deployed in support of Operation Iraqi Freedom and Operation Enduring Freedom, most recently serving as the Regional Command South operations officer in Kandahar. His education includes a bachelor's degree in Civil Engineering from the United States Military Academy, and masters' degrees from the Naval and Army War Colleges.

### **Contributing Authors**

Nicholas Hargreaves-Heald is currently a Master's candidate at the Fletcher School of Law and Diplomacy and a research intern with the U.S. Naval War College's Center on Irregular Warfare and Armed Groups (CIWAG). His work focuses broadly on irregular warfare, unconventional warfare, and relationships between state and non-state actors. He has conducted extensive research into Iran's Quds Force and proxy forces across the region, as well as IRGC battlefield innovations.

Hiram Reynolds is a master's candidate at the Fletcher School of Law and Diplomacy studying international law, security, and East Asian history and politics. His particular focus is emerging irregular warfare and trans-domain security challenges and their implications for international norms of territorial sovereignty. Hiram currently works on the Regulatory and Government Affairs team at State Street, assisting with FinTech and APAC regulatory policy. He previously worked at the HAX engineering and entrepreneurship hardware accelerator in Shenzhen, as a Fulbright Fellow in Indonesia, as a trip leader for leadership development programs in China and in Sweden, and at a research center of National Defense University in Washington, D.C.

Hannah Smith is a 2018 graduate of Dickinson College where she studied Political Science, Spanish and Security Studies. Previously, Hannah worked as a research assistant at the William J. Perry Center for Hemispheric Defense Studies, a Department of Defense Regional Center. At the Perry Center, she conducted research in both Spanish and English with a focus on the crime-terror nexus in Latin America- specifically examining the Revolutionary Armed Forces of Colombia (FARC) throughout the demobilization process. During her time as an undergraduate student, Hannah studied at the University of Buenos Aires, Argentina, the University of St Andrews, Scotland, and IDC Herzliya, Israel. Her interests include non-state governance and irregular warfare, specifically in Latin America.

## TABLE OF CONTENTS

Forward .....	iii
About the Authors .....	v
Table of Contents .....	vii
Stability in Multi-Domain Battle.....	1
The Operational Environment .....	5
The Multi-Domain Battle Concept .....	9
Stability in the Multi-Domain Battle Concept.....	12
The Future of Stability in Multi-Domain Battle - Challenges and Opportunities .....	15
Stability Related Challenges.....	20
Potential Stability Traps.....	35
Conclusion .....	38
Appendix A: Stability Targeting and Counter- Destabilization.....	41
Appendix C: Case Study - The Islamic Republic of Iran: Targeting the Security Sector .....	63
Appendix D: Case Study - The People’s Republic of China: Economic Targeting.....	75



Appendix E: Transitional Public Security .....	89
Appendix F: Notes on Terminology.....	103
Appendix G: Additional Questions for Future Exploration.....	107
Endnotes.....	113

Multi-Domain Battle (MDB) is an operational concept developed by the U.S. Army Training and Doctrine Command (TRADOC) that describes ground combat operations against sophisticated peer and near-peer threats. In February 2017, TRADOC published a white paper titled “Multi-Domain Battle: Combined Arms for the 21<sup>st</sup> Century” to initiate the discussion of MDB across the Army and the Joint Force. TRADOC subsequently published a more detailed description of MDB in “Multi-Domain Battle: Evolution of Combined Arms for the 21<sup>st</sup> Century 2025-2040” along with the new *Army Operations* doctrinal series (ADP 3-0, ADRP 3-0, and FM 3-0) in October 2017.<sup>1</sup> These documents are designed “promote thought and discussion concerning the methods and capabilities required to confront sophisticated adversaries” as well as “to inform further concept development, wargaming, experimentation, and capability development.”<sup>2</sup> MDB is an Army concept; however, as a concept, it involves the entire Joint Force, and further work is required to refine and expand the concept across all services and functions.

While the MDB concept specifically addresses the 2025-2040 timeframe, many of the central ideas are valid in today’s complex operational environment. The newest version of FM 3-0 *Army Operations* introduces aspects of MDB and the extended battlefield framework in doctrine. FM 3-0 states that “the Army conducts operations across multiple domains and the information environment. All Army operations are multi-domain operations, and all battles are multi-domain battles.”<sup>3</sup> FM 3-0 also highlights the military application of rapidly advancing technologies in the information environment, cyberspace, space, and the electromagnetic spectrum that require special consideration during planning and execution. A

fundamental future Army capability will be the Army's ability to converge effects across all domains.<sup>4</sup>

Stability is a fundamental component of Multi-Domain Battle. The purpose of this PKSOI white paper is to describe the role that stability plays in MDB and to further inform concept development with respect to Joint Force and Army stability actions. Integrating stability activities with MDB provides the entire Joint Force with increased decision space and expands freedom of operation. It is the only way that the U.S. Government can transition successful military operations to lasting political solutions. Stability actions during competition identify and counter adversary campaigns; build partner capability, capacity, and resilience; and support deterrence. Stability actions during armed conflict increase the options for the application of all instruments of national power and protect the legitimacy of the U.S. integrated campaign. Finally, stability actions following armed combat prevent an adversary from reversing friendly gains, reestablish civilian control, and create a sustainable future.

This white paper is divided into three sections. The first provides an overview of MDB and describes the changes to the operational environment that are driving the concept's development. Part two describes the role stability plays in the current concept during competition and armed conflict. Part three highlights stability-related MDB challenges and traps, and provides recommendations for continued refinement. Appendix A examines stability from an adversary's perspective in order to gain insights on how they target the stability sectors throughout their operations to achieve advantageous strategic outcomes. Appendixes B, C, and D (each written by a contributing author) are case studies that examine a

broad range of stability targeting efforts by an equally broad range of state and non-state actors. Appendix E discusses the role of transitional public security in the multi-domain environment, while Appendixes F and G establish definitions of the terms used throughout the paper and highlight the way forward for continued research and development.

Our initial observations are as follows:

- To succeed in Multi-Domain Battle, the Army must be able to positively affect the five stability sectors both directly and through integration with the Joint Force and interorganizational partners. The Army must understand how adversaries target stability throughout the competition continuum, and develop effective strategies to preempt or counter adversary actions in concert with other U.S. Government departments and agencies.
- The Multi-Domain Battle concept is rightly optimized for the most dangerous threat that the United States will face in the future. MDB should and can be adapted to address threats below the level of armed conflict with a peer competitor. The objective of MDB should be to prevent competition from escalating to armed conflict through proactive stabilization and counter-destabilization efforts. This emphasis will also nest MDB within the *Joint Campaign for Integrated Campaigning* and *National Security Strategy*.
- While stability has always been associated with consolidating gains, stability has

traditionally been discussed in the terms of post-conflict actions and tasks. The Army should reconsider its approach to stability within the multi-domain context. During competition, stability protects our allies and partners. During armed conflict, the Army will be called upon to conduct stability tasks to protect the legitimacy of United States Government (USG) integrated campaigns. During the return to completion, stability paves the way for transition.

- The Army must better understand its role with respect to stability during competition and armed conflict. It must understand, plan, and account for second and third order impacts of military operations on stability in order to enable other departments and agencies within the USG to function effectively.
- Stabilization (proactive stability combined with counter-destabilization) works when diplomatic, development, defense, and other USG actors conduct deliberate coordination and planning, assess the environment, develop shared understanding, and develop common priorities. This will become more difficult as the environment becomes more complex.

## The Operational Environment

Two considerations drive the need to reconsider how the Army will operate in the future. The first is that the traditional Western perspective of war and peace as binary and mutually exclusive is obsolete. The war-peace dichotomy has been replaced by a model of cooperation, competition, and armed conflict that describes *states of relationships* with other actors and where those states can exist *concurrently*.<sup>5</sup> The second consideration is that the Department of Defense's assumption of domain superiority is no longer valid as contemporary U.S. adversaries are increasingly able to operate in and contest the United States across all domains. This flawed assumption has driven Joint Force doctrine, equipping, and force posture decisions since the fall of the Soviet Union; however, as the character of warfare changes, so must the Joint Force's conceptualization, operational approach, and execution.

TRADOC's MDB concept adopts and expands on the operational environment described in the CJCS's *Joint Operating Environment 2035* (JOE 2035). JOE 2035 describes two overarching challenges that the United States will face. The first challenge is that revisionist states and non-state actors can and will *contest the international order and norms* established and maintained by the United States and its allies since the end of World War II. These actors will use all instruments of power available to them (not just military force) to establish alternative norms that are unfavorable to U.S. national interests. The second challenge is the transition from a nation-state determined order to a more complex environment where global commerce, technologies, and telecommunication advances can exceed the strength of participating states. This transition is driving *persistent*

*disorder*. Persistent disorder enables U.S. adversaries to exploit the inability of states to provide functioning, stable, and legitimate governance.<sup>6</sup> These challenges, together with accelerating information and technology advances, urbanization, global networking, access to technology and ‘weapons of mass effects,’ and the very nature of multinational operations, are increasing the complexity of the operational environment exponentially and making it much more difficult to effectively deter potential opponents.

U.S. adversaries (both state actors and non-state groups) are investing in capabilities that will significantly impact the future operational environment. These capabilities will not only impact combatants during armed combat, but will also shape a government’s decision space short of combat. Improved ballistic missile systems and precision strike capabilities are expanding the battlefield framework in time and space – targets that were once out of range are no longer safe from enemy attack. Future enemies will avoid close combat with the United States and its allies through layered standoff and denied access (e.g., integrated air defense systems). Lethality throughout the operational area is increasing as our adversaries field new weapon systems that may prevent the Joint Force from achieving overmatch and force it to operate as much smaller, more dispersed elements without assured connectivity.<sup>7</sup> The result is a ‘hyperactive’ battlefield where the “differences between strategic, operational, and tactical levels, as well as between offensive and defensive operations, are being erased,”\* and that can quickly overwhelm the capacity and will of any combatant.

\* TRADOC discusses how battlespace is becoming compressed on page seven of the MDB concept paper. Interestingly, Russian General of the Army Valery Gerasimov makes the same observation in his important article, “The Value of Science Is in the Foresight,” *Military Review* (January-February 2016), 24.

As U.S. adversaries build capacity, they are also adapting their approaches based on observations of U.S. actions (combat and non-combat alike) throughout the world. Instead of attacking our physical strengths, adversaries will leverage their centralized political and military systems to exploit virtual and cognitive seams within established U.S. operational approaches and planning methodology. Their objective is to create “a *fait accompli* before the Joint Force can react...by operating under the threshold that triggers a decisive U.S. counter-reaction.”<sup>8</sup> Colloquially, these seams are referred to as the “gray zone,” a term made popular within DoD by a 2015 USSOCOM white paper.<sup>9</sup> The *Joint Concept for Integrated Campaigning* (JCIC) codifies the “gray zone” concept as the *competition continuum* – a flexible spectrum of strategic relations that range from cooperation to competition below armed conflict to armed conflict itself (see Figure 1). These three elements of the continuum are not exclusive of each other and will often co-exist at the same point in time.

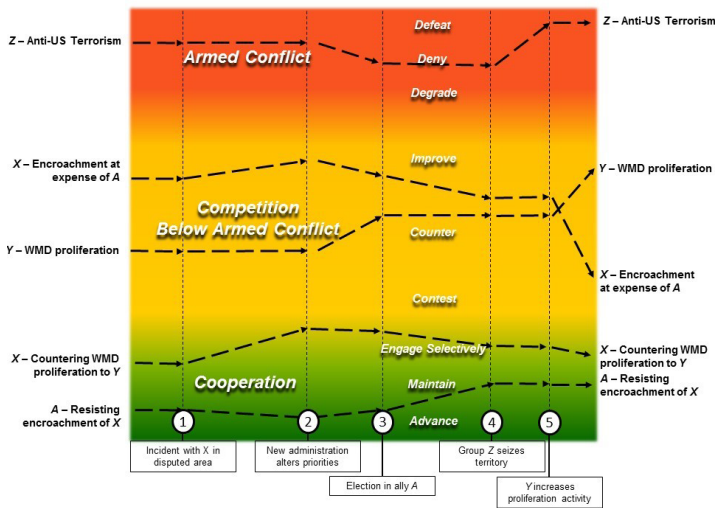

Figure 1. The Competition Continuum<sup>10</sup>



Competition below the threshold of armed conflict spans the competitive space between the traditional norms of peace and conflict. It is characterized by political, economic, informational, and military competition that goes beyond 'steady-state diplomacy,' yet remains short of conventional war. Competition is nothing new – in 1948 George F. Kennan wrote a memorandum for the Department of State on "The inauguration of political warfare" where he called Russia's use of all the means at their command, short of war, to achieve its national objectives "the most refined and effective of any in history." Kennan concluded that the United States struggles during competition because "we have been handicapped by a popular attachment to the concept of a basic difference between peace and war, by a tendency to view war as a sort of sporting contest outside of all political context, by a national tendency to seek a political cure-all, and by a reluctance to recognize the realities of international relations."<sup>11</sup>

What is new is "the number of actors simultaneously empowered to resist U.S. influence effectively, the variety of routes and vectors from which they can threaten harm to core U.S. interests, and, finally, the volatility of an international system under persistent seismic pressure from the competing forces of integration and disintegration."<sup>12</sup> Increasingly, U.S. adversaries are adapting technological advances to more effectively target the vary stability sectors that underpin the societies they want to influence or control. U.S. plans and actions that do not account for these complex realities will fail to secure and maintain national policy objectives.<sup>13</sup> Taken together, these challenges will have a profound impact on how the Army approaches its role in stability.

## The Multi-Domain Battle Concept

Since the United States can no longer guarantee domain superiority, MDB requires a Joint Force that is able to outmaneuver “adversaries physically and cognitively through the extension of combined arms across all domains.”<sup>14</sup> In addition to cross-domain maneuver, the Army must “integrate and synchronize capabilities as part of a joint team to create temporary windows of superiority across multiple domains and throughout the depth of the battlefield in order to...achieve military objectives.”<sup>15</sup> Cross-domain maneuver, integrated capabilities, and temporary windows of advantage all aim to “affect an adversary in both the physical and abstract domains creating dilemmas too numerous to counter.”<sup>16</sup> The MDB concept addresses all three components of the JCIC’s competition continuum, and for the first time truly addresses actions that must take place short of traditional war.

The Army’s ability to execute MDB rests on three critical components. The first is *force posture* consisting of forward presence, expeditionary forces, and integrated partner capabilities. Forward presence is required to support less capable allies and partners, to recognize and counter adversary operations that target allies and partners, and to provide a ‘regional foothold’ inside an adversary’s anti-access system should competition escalate to armed conflict. Trained and supported partner forces are uniquely suited to counter adversary information and unconventional warfare. Integrating forward presence with partner capabilities is the most effective posture from which to contest the destabilization actions that are part of the adversary’s overall campaign plan.

The second component is *resilient formations*. To effectively operate within the MDB environment, Army units will require the capabilities to deliver effects across multiple domains. Formations will need the ability to avoid detection and survive contact with an enemy through integrated reconnaissance and security operations. Units will have to operate semi-independently as they maneuver and fight as smaller and more dispersed elements, often without contiguous supply lines or secured flanks. Because our adversaries have the ability to degrade the Army's command and control architecture, the ability to execute real mission command at all times regardless of the condition of the network and cross-domain enablers will be critical.

The third and most significant component is *convergence* - the ability to integrate capabilities across domains, environments, and functions in time and space to achieve a purpose. While convergence is similar to current efforts to synchronize combat power, MDB relies upon the integration of interorganizational\* capabilities and the application of combat power across multiple domains. The goal of convergence is to create physical, virtual, and cognitive windows of advantage that the Joint Force can exploit to gain a position of advantage. These windows will often be temporary, and will enable action in other domains from the land domain.

\* The terms "interorganizational" and "interagency" are both used throughout this paper. Interorganizational refers to "interaction that occurs among elements of the DoD; participating USG departments and agencies; state, territorial, local, and tribal agencies; foreign military forces and government agencies; international organizations; nongovernmental organizations; and the private sector." Interagency refers to "USG agencies and departments, including the DoD." See Joint Staff, *JP 3-08 Interorganizational Cooperation* (Washington, DC: The Pentagon, October 12, 2016), p. GL-9.

Because our adversaries are increasingly capable of contesting the Joint Force across all domains and over extended distances, the current concept of deep, close and rear areas is inadequate to frame multi-domain operations. The new MDB operational framework (see Figure 2) significantly expands the geographic and cognitive battlespace by including strategic, operational, and tactical support areas, a deep maneuver area, and operational and strategic deep fires areas. While Figure 2 depicts a linear arrangement of these areas, each conflict arena will be organized differently based on the adversary’s capabilities. The component areas of the framework may or may not be linear, and they may or may not be contiguous.

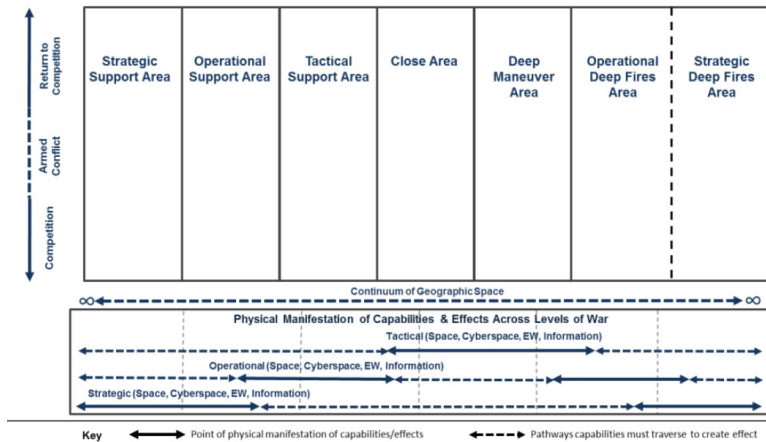

**Figure 2. The Multi-Domain Operational Framework**

## Stability in the Multi-Domain Battle Concept

Current Army doctrine integrates offensive, defensive, and stability tasks throughout all phases of an operation. Stability is fundamental to “operations conducted before, during, and after conflict.”<sup>17</sup> The MDB concept addresses stability throughout the competition continuum. While the concept discusses stability from a military perspective, it is imperative that the Army understands stability through the lens of integrating military action with the other instruments of national power and linking military operations to political objectives.

**Competition.** Stability actions are a critical component of competition activities and are prominently featured in TRADOC’s MDB concept. During competition, adversaries will seek to “separate or isolate friendly forces politically, limiting a coordinated allied response and destabilizing target states internally to attain [their] objectives below the threshold of armed conflict.”<sup>18</sup> To prevent an adversary from gaining positions of advantage, the Joint Force in concert with interorganizational partners conducts proactive stability actions, contests the adversary’s destabilization actions, deters escalation, and prepares for transition to armed conflict if escalation continues. As seen in multiple theaters, “adversaries will continue to creatively combine conventional and non-conventional methods to achieve objectives by operating below a threshold that would invoke a direct military response from the U.S. while retaining the capability to engage in more conventional armed conflict.”<sup>19</sup>

Fundamental to MDB is the Army's responsibility to counter an adversary's destabilization actions by applying the military instrument of power or through integration with interorganizational partners. Simply building partner capacity across the five Joint Stability Functions is not enough. The United States must also counter an adversary's destabilization efforts that adversely impact national interests (see Appendix A, Stability Targeting and Counter-Destabilization). Key U.S. targets will be the adversary's unconventional and information warfare campaigns. Stability actions are integral to opening windows of advantage during competition that will be required should the situation escalate to armed conflict. These windows include territorial access (physical), authorities (physical, virtual, and cognitive), popular or government support (cognitive), and expanded partner capacity across all of the Joint Stability Functions (physical and cognitive).<sup>20</sup>

**Armed Conflict.** TRADOC's MDB concept paper does not address stability operations during armed combat directly. Despite the emphasis on offensive operations to "defeat the enemy's conventional forces in a rapid campaign of maneuver across all areas of the extended battlespace in multiple domains and locations simultaneously,"<sup>21</sup> failure to incorporate stability actions during armed conflict will limit the decision and 'maneuver' space for the employment of other elements of national power—diplomacy, information, economics, finance, intelligence, and law enforcement—during both armed conflict and the return to competition. During conflict, an adversary will continue to use unconventional warfare and information efforts to erode political will and fracture multinational alliances, coalitions, and partnerships. Combined, these factors will prevent the United States

from setting the conditions necessary to ensure a conclusive political victory following decisive combat wins.

Joint Force missteps with respect to stability (especially security and governance) will amplify the effects of an adversary's campaign. The second and third order effects of offensive and defensive operations during armed conflict can have an enormous impact on stabilization. Greater emphasis on stability actions and a deeper understanding of these second and third order effects will provide greater flexibility for the Joint Force. It will also create more options for the Joint Force to create and exploit windows of advantage in order to physically, virtually, and/or cognitively seize the initiative. Ultimately, Joint Force stability actions during armed conflict enable the "translation of military results [rapidly reducing the enemy's capacity to resist, retain, or retake key terrain] into political objectives or a sustainable outcome in the return to competition."<sup>22</sup>

**Return to Competition.** The U.S. experiences in Afghanistan, Iraq, Libya, and Syria demonstrate that stability actions are vital during and following armed conflict and during the return to competition. While similar to competition, there are two primary differences. First, even if the United States and its partners successfully accomplish all of the military objectives, it is unlikely that the conflict will end with a decisive victory or a definitive political settlement. The environment will remain competitive long after the enemy's main forces no longer pose a direct threat. Adversaries will attempt to take advantage of the volatility following armed conflict to continue to subvert and attack friendly forces *and institutions* in order to limit the United States' ability to consolidate

gains, to re-impose its will on the region, and to maintain some level of influence in the region.

In order to prevent a resumption of armed conflict, the Joint Force must “retain the initiative won during conflict and consolidate gains by helping restore public services, reestablish law and order, and isolate and defeat the adversary’s subversive activities.” As with competition, the Joint Force must operate both defensively (building stability capacity) and offensively (counter adversarial efforts) to create a sustainable future. The second difference is born out of the lessons learned in Iraq, Afghanistan, and elsewhere that the “successful execution of ‘dominating activities’ [during armed combat] does not automatically lead to the achievement of desired political objectives.”<sup>23</sup> This requires the Joint Force to converge lethal and non-lethal military capabilities with political actions. This convergence with respect to stability is the essential requirement to consolidate gains.

## **The Future of Stability in Multi-Domain Battle - Challenges and Opportunities**

Future conflict will take an almost infinite number of forms. Geography, actors, and alliances will influence the character of conflict; while resources, will, and national interests will determine the intensity and duration of the conflict. The current MDB concept is rightly optimized to enable the United States to prevail in a “most dangerous” scenario involving a peer or near-peer enemy with the capability to contest the United States in multiple domains simultaneously, challenge U.S. overmatch, and deny the United States the ability to achieve domain superiority. The “most dangerous” scenario may not be the most likely scenario; however, not preparing for it would risk catastrophic failure at the national level.



TRADOC highlights five “problems” for U.S. forces in the “new” MDB expanded battlespace.<sup>24</sup>

1. *How do U.S. forces deter the escalation of violence, defeat adversary operations to destabilize the region, and turn denied spaces into contested spaces should violence escalate?*

2. *How do U.S. forces maneuver from contested strategic and operational distances and with sufficient combat power in time to defeat enemy forces?*

3. *How do U.S. forces conduct deep maneuver by air, naval, and/or ground forces to suppress and destroy enemy indirect fire and air defense systems and reserve forces?*

4. *How do U.S. forces enable ground forces to defeat the enemy in the Close Area?*

5. *How do U.S. forces consolidate gains and produce sustainable outcomes, set conditions for long-term deterrence, and adapt to the new security environment?*

Figure 3 depicts these challenges against the backdrop of the MDB extended battlefield framework:

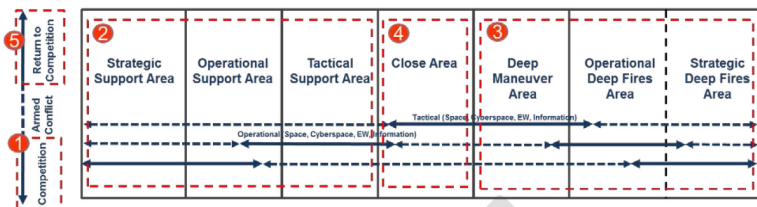

**Figure 3. Problems in the “New” Battlespace**

The MDB concept should and can address competition and armed conflict with adversaries short of the peer and near-peer levels. Figure 4 is a simplistic way to diagram four potential forms of conflict against the JCIC’s competition continuum. While the figure fails to account for every plausible scenario and depicts a linear version of the competition continuum (remember that cooperation, competition, and armed conflict are not mutually exclusive and can co-exist simultaneously), it does demonstrate the broad range of scenarios that the multi-domain battle concept must be able to address.

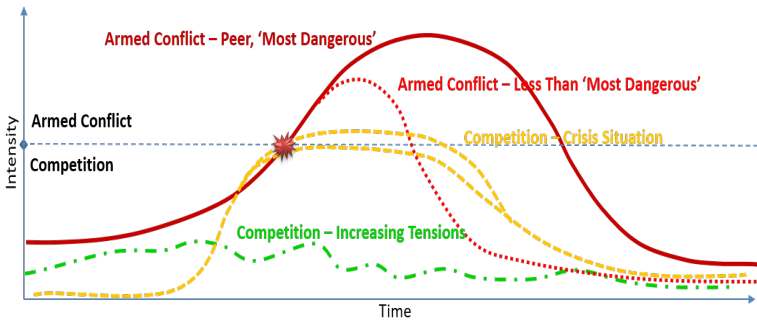

**Figure 4. Potential Forms of Conflict**

Scenario one (dark red solid line) represents the “most dangerous” scenario discussed above. The dark red line traces the path of ‘traditional’ conflict from the competition stage to a point where increasing tensions lead to open conflict. At the conclusion of armed conflict, the actors return to a state of competition where both attempt to consolidate gains and impose or re-impose their will in the region. To achieve its political goals, the United States must retain a position of advantage in the region that its adversaries cannot challenge or undermine by reducing an adversary’s ability to effectively compete with the United States and the host nation.

Scenario two (light red dashed line) is similar to Scenario One. It represents a crisis that still escalates to armed conflict, but whose duration and intensity of armed conflict is decreased because of successful stabilization efforts. Successful stabilization efforts result in a quicker return to competition and a strengthened position of advantage for the United States. History, however, shows that the most dangerous scenarios are also the least likely scenarios to unfold.

Scenario three (orange dashed line) represents a situation where the United States enters into competition late, either by design, due to surprise, or through failure to recognize competition. The United States applies stabilization actions to assist a partner; however, the intensity of the competition continues to increase. The increasing competition may lead to limited armed conflict, but the situation eventually returns to competition. There are several conditions that are typical in this environment: A subnational illegal armed group is gaining strength in a fragile state that the state is unable to address and contain within its borders, a crisis in one country threatens to destabilize a region, the region has the will to address a cross-border threat, military action alone cannot decisively end a security crisis, and the USG must use mutually reinforcing regional and bilateral strategies and tools.\*

Scenario four (green dashed line) represents the best-case scenario. The United States identifies competition

\* The Lake Chad Region (LCR) is an example of Scenario Three. Within the LCR, the humanitarian and security situation had deteriorated significantly before the United States became fully engaged. Working with regional partners, the United States sought to “degrade and defeat...Boko Haram so that it would no longer pose a threat to the region, mitigate Boko Haram’s impact on the region’s citizens; and address the underlying conditions that gave rise to Boko Haram.” See Beth Cole, Alexa Courtney, Erica Kaster, and Noah Sheinbaum, *Breaking Boko Haram and Ramping Up Recovery: US Engagement in the Lake Chad Region 2013 to 2016* (Washington, DC: United States Institute of Peace (USIP), 2017), 8-9. See also Beth Cole, “Fostering Diplomatic-Defense-Development (3D) Cooperation in Responding to Complex Crisis,” USIP (Washington, DC, December 2017), 3.

in a region that challenges its national interests. To protect those interests, it conducts a synchronized and integrated stabilization campaign consisting of proactive stability and counter-destabilization efforts, and successfully deters either escalation or further destabilization. Competition exists (and can intensify at times), but it does not rise to the level of armed conflict. Over time as U.S. stabilization efforts take root, the intensity of competition diminishes as the United States and its partners consolidate gains while preventing an adversary from re-imposing its will. Conditions typical of this scenario include U.S. national security interests in preserving the stability of a key ally in a region engulfed by conflict and instability; the United States provides assistance that requires a high degree of coordination; cross-border assistance to neighboring populations affected by conflict is required; the prospect of a long-term refugee presence in a priority country demands long-term solutions; and the security environment in the host country is relatively permissive.\*

\* A contemporary example of Scenario four is Jordan where the United States successfully “prioritized managing destabilizing internal stressors, addressing humanitarian and security needs in Syria, and preventing violent extremist activity from threatening Jordan’s security.” See Beth Cole, Alexa Courtney, Erica Kaster, and Noah Sheinbaum, *Preserving Stability Amidst Regional Conflagration: US Engagement in Jordan 2011 to 2016*, (Washington, DC: USIP, 2017), 6-7. See also Beth Cole, “Fostering Diplomatic-Defense-Development (3D) Cooperation in Responding to Complex Crisis,” USIP (Washington DC, December 2017), 3.

While each of these four scenarios vary significantly in terms of time, intensity, and commitment, all have several common aspects. In each scenario, addressing stability (and countering instability) is essential to managing the competitive environment. Even if not successful in deterring escalation, stabilization can limit the intensity and duration of armed conflict. Actions and decisions made during armed conflict will impact stabilization efforts during the return to competition. Stabilization during the return to competition will always be required to consolidate gains and achieve an enduring satisfactory political solution.

## **Stability-Related Challenges**

TRADOC's five problems are best depicted against the backdrop of the extended battlefield framework. In contrast, the stability-related challenges are best understood when described in terms of the competition continuum where cooperation, competition, and conflict may exist simultaneously (see Figure 5).

1. During competition, the Department of State (DoS) will be the supported USG department, while DoD will be the supporting department. *How do Army forces support DoS-led efforts during competition to create and exploit windows of advantage, while operating with limited authorities? (Figure 5, Item 1)*
2. Our adversaries will use all elements of power at their disposal during competition, not just military (Russia for example advocates a 4:1 ratio of non-military to military means during 'conflict development'<sup>25</sup>). *How do forward*

*deployed or expeditionary Army forces recognize competition when the vast majority of destabilizing mechanisms employed by an adversary may be non-military? (Figure 5, Item 2)*

3. MDB requires converging military and interorganizational capabilities across multiple domains at all times. *How does the Army (as part of the Joint Force) enable the USG to more effectively converge diplomatic, informational, and economic forms of power during cooperation, competition, and armed conflict? (Figure 5, Item 3)*
4. During armed combat, DoD will assume the lead role and employ the elements of military power to achieve military objectives. *How does the Army achieve military objectives throughout the competition continuum while simultaneously preserving or increasing the options to employ other elements of national power that will be required for a sustainable political outcome? Simultaneously, how can the Army enable other USG agencies to engage in stabilization efforts themselves throughout the continuum in order to set the conditions for stabilization success and leading to a satisfactory political solution? (Figure 5, Item 4)*

These stability gaps are integral to TRADOC's five problems, and are discussed in greater detail below.

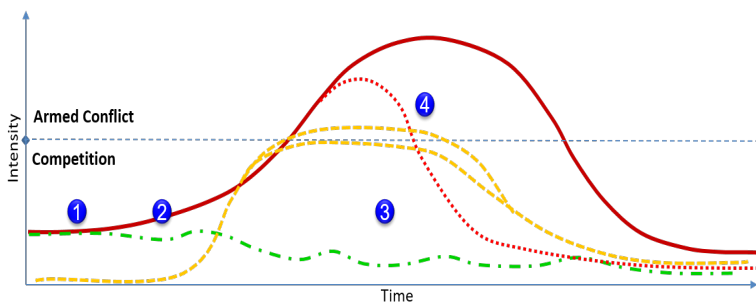

**Figure 5. Stability Related Gaps in MDB**

**1. How do Army forces support DoS-led efforts during competition to create and exploit windows of advantage, while operating with limited authorities?**

U.S. Code clearly delineates the roles, responsibilities, and authorities of each government department and agency during competition and armed conflict. The JCIC recognizes that the "Department of State will often function as lead in situations involving competition short of armed conflict."<sup>26</sup> The challenge for the Army and the Joint Force is that "state and non-state adversarial approaches are accomplishing wartime-like objectives beyond the reach, authorization, and effectiveness of existing theater campaign efforts and US law, title, and code."<sup>27</sup>

Future conflicts will require the Army to synchronize with the Joint Force and integrate with interorganizational partners who will be better postured to operate due to their authorities, but will also have

much less capacity (in terms of manpower, presence, and resources) than the DoD. The Army's ability to directly influence foreign governance structures, justice systems, and economies is exceedingly limited (and this limitation is especially acute during cooperation and competition); however, the Army has often been called upon to fill the gap between requirements and capacity, especially during armed combat and the period immediately after. The same could become increasingly true during competition as resources decline.

Co-location by itself will not lead to cooperation. Army leaders need to understand country team dynamics within an embassy. These dynamics are often driven by personalities, and they will be different in every country and in every situation. Army personnel must be fully integrated into country teams by selecting the right people for the Defense Attaché and Security Cooperation offices. Most importantly, Army leaders need to understand the authorities (and approvals) that interagency partners possess, and how they can leverage those authorities to strengthen U.S. positions of advantage. The Army must also employ its capabilities on behalf and in support of interagency partners in the pursuit of common policy goals. These include the Army's level of access afforded by security; unique authorities; the ability to conduct detailed planning and analysis; and personnel, platforms, and partnerships that can augment department and agency capacity. USAFRICOM is a unique example of Joint Force cooperation with and support to the interagency. Much of USAFRICOM's success can be attributed to its ability to "meet country teams on their own turf" and shape its headquarters to "provide a critical strategic platform that the civilian agencies hadn't realized they lacked."<sup>28</sup>



Military actions can create windows of opportunity for the application of other elements of national power. Conversely, they can limit the effectiveness or constrain the actions of interorganizational partners. It is critical that the combined U.S. interagency team understands the less obvious levers of power that exist in the environment. The Embassy's Integrated Country Strategy must address how the United States can coordinate with, coopt, or isolate these power structures depending on what fits the long-term strategic ends and not merely the immediate objectives. The campaign plan must enable the United States to be proactive (and not merely reactive) by identifying leverage points that can be engaged when needed should competition continue to intensify and lead to conflict. Targeting adversary actions during competition will require the Army to identify the interagency partner best positioned with the authorities and capabilities to deliver the greatest effects against the adversary's destabilization actions.

It is also critical that the U.S. Army (and the Joint Force as a whole) understands and appreciates the inherent differences between DoD and the departments and agencies it supports. Capacity and capability are not the only disparities between the Army and its interorganizational partners - often their mission, sense of urgency, time horizons, ways, and means will vary substantially. Moreover, their very definition of success may differ from MDB concerns during competition and armed conflict. As opposed to "winning" competition, the DoS and the U.S. Agency for International Development (USAID) will seek to manage relationships, conflicts, and trends in the international community - thus the concept and nomenclature of "battle" may not translate well despite a common understanding of MDB challenges writ

large. Perspective is important, and the Army must understand the divergent assessments and viewpoints within the overall team.

## **2. How do forward deployed or expeditionary Army forces recognize competition when the vast majority of destabilizing mechanisms employed by an adversary may be non-military?**

Perhaps the most important observation in General Gerasimov's article is that the "very 'rules of war' have changed. The role of nonmilitary means of achieving political and strategic goals has grown, and, in many cases, they have exceeded the power of force of weapons in their effectiveness."<sup>29</sup> Gerasimov goes on to say that "the focus of applied methods of conflict has altered in the direction of the broad use of political, economic, informational, humanitarian, and other nonmilitary measures - applied in coordination with the protest potential of the population [and] supplemented by military means of a concealed character."<sup>30</sup> Russia is not alone in this approach - China, Iran, and North Korea all operate below the threshold of armed conflict and all use a combination of non-military and military means.

TRADOC's MDB concept states that our adversaries will converge "military and non-military capabilities through four interrelated systems - reconnaissance, unconventional warfare (UW), information warfare (IW), and conventional forces - and over time, across areas, and in purpose to fracture alliances and isolate targets."<sup>31</sup> Army forces operating in a country or region where an adversary employs these four interrelated systems can be reasonably expected to identify an adversary's military activities (especially with respect to security efforts). However, the U.S. Army will be

challenged to observe adversary actions that target the other stability sectors highlighted by General Gerasimov that are all aimed at “reducing the fighting potential of the enemy.”<sup>32</sup>

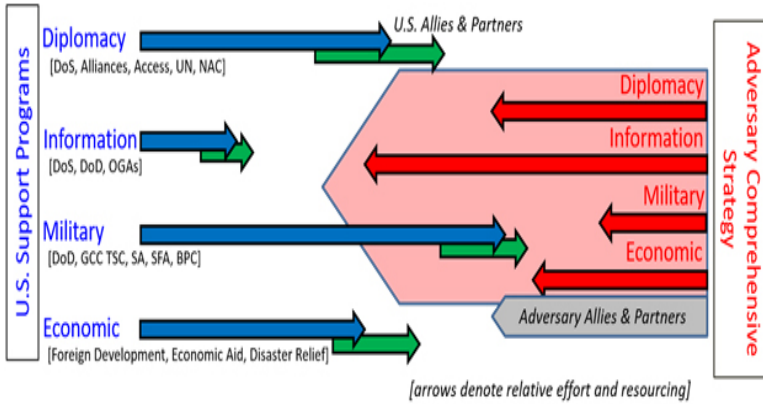

**Figure 6. Asymmetry during Competition**

U.S. adversaries will always use an asymmetric approach during competition (Figure 6 demonstrates this approach). During competition, diplomatic efforts conducted by the embassy country team drive all U.S. actions. The United States routinely invests significant effort and resources in security cooperation in support of diplomacy, and U.S. military presence is often one of the most visible aspects of U.S. efforts abroad. Other efforts include aid programs in developing countries that target economic stability and social well-being. In contrast, our adversaries use their centralized (and authoritarian) forms of governments in ways that enable them to leverage and, most importantly, synchronize actions across all elements of national power in a way that preserves long-term strategic options. The U.S. is handicapped in this regard by a political system of checks and balances with independent departments

that answer to executive authority and are typically oriented on shorter-term objectives. Further, as demonstrated by the U.S. approach in Afghanistan, Iraq, Libya and Syria, the U.S. struggles to synchronize efforts across departmental boundaries; authoritarian forms of government typically do not.

Since it is easier for our adversaries to effectively synchronize their elements of power, the four interrelated military systems of reconnaissance, UW, IW, and conventional force will only be a part of their overall political strategy. This creates an imbalance in U.S. collection capabilities. During competition, the Joint Force will have to be able to recognize when an adversary employs non-military measures. Joint Forces, regardless of type and primary function in country (e.g. regionally aligned forces, security force assistance elements, state partnership program units, Special Operations Forces), need to be equipped with specific intelligence requirements that are focused on the destabilization tasks within an adversary's campaign plan. Between the embassy country team, the Geographic Combatant Command (GCC) and the Theater Special Operations Command, is there a more efficient way to holistically manage information collected by the different elements of the country team, analyze that information, and distribute the intelligence in a way that identifies destabilization actions earlier and gets that intelligence to the organization(s) with the authorities and approvals to act in the best interest of the United States?

**3. How does the Army (as part of the Joint Force) enable the USG to effectively converge diplomatic, informational, and economic forms of power during cooperation and competition?**

Convergence is one of the central themes of MDB. TRADOC concedes that the “requirement to employ formations to create and exploit windows of advantage throughout the depth of the expanded battlespace over time ranging from seconds to years represents the greatest challenge for commanders posed by the new operating environment.”<sup>33</sup> The Joint Force must be able to converge all aspects of military power in order to successfully wage multi-domain battle; however, “military power alone is insufficient to achieve sustainable political objectives, and there are limited means to achieve integration across the instruments of national power.”<sup>34</sup> This is not a new concept – our recent conflicts and on-going difficulties at the policy level demonstrate how difficult it is to achieve integration at the national level – but MDB requires a new level of collaboration, integration, and synchronization of capabilities across all elements of national power.

The Department of Defense cannot (and should not) pull the diplomatic, informational, or economic levers of power; however, the Army or other services may be in a position to facilitate or enable the actions of other USG departments. The JCIC defines integrated campaigning as “Joint Force and interorganizational partner efforts to enable the achievement and maintenance of policy aims by integrating military activities and aligning non-military activities of sufficient scope, scale, simultaneity, and duration across multiple domains.”<sup>35</sup> This definition highlights the role that non-military activities will play throughout an operation, but particularly during competition. The critical opportunities to align military and non-military activities occur throughout the planning cycle and following every assessment period. Not only must the DoD articulate its plan to integrate and align Joint

Force activities, it “must also plan and provide support to and coordination with other U.S. departments and agencies, as well as other interorganizational partners.”<sup>36</sup>

The JCIC introduces four elements to assist with effective cross-department and/or agency planning:

- Understand the operating environment using the competition continuum and use terminology that fosters *better civil-military dialogue and collaboration*
- *Design the campaign using the factors of integrated campaign design* and competition mechanisms to align military and non-military activities
- Employ the Integrated Force and *secure gains* in campaigns tailored to the new operating environment
- *Assess and adapt the campaign* based on continuous evaluation

Two tool sets are especially relevant for the U.S. Army. The first tool consists of the *factors of integrated campaign design* (bullet two above). These factors better link military efforts with overarching policy by clarifying the relationship between civilian guidance and military objectives, facilitating collaboration with essential USG and international partners, and improving the application of operational art beyond the narrow conception of armed conflict.<sup>\*37</sup>

\* The JCIC’s factors of integrated design include: diagnosis, anticipate consequences, effective civil-military dialogue, outcomes, follow through, benefits and risk, narrative, empowerment, alignment, resourcing, prevailing logic, and multi-domain force architecture.

The second tool introduced by the JCIC is the concept of *competition mechanisms*. Like the factors of integrated campaign design, the competition mechanisms are additive and supplement the defeat (defeating armed enemies through the organized application of force) and stability (primary method by which the Joint Force affects the human dimension) mechanisms in JP 5-0, *Joint Planning*. Competition mechanisms are “applicable to the strategic realities of armed conflict, competition below the level of armed conflict, and cooperation as ways to maintain or establish favorable conditions within the international order.”<sup>38</sup> Four of the seven competition mechanisms focus on support: *Strengthen, Create, Preserve, Inform*. *Weaken* directly counters the adversary’s approach. *Position* and *Persuade* can be used to both support a partner and to counter an adversary.

During competition, supporting a partner while countering the adversary’s approach are two sides of the same coin; however, the U.S. has typically emphasized support over countering. Additional emphasis needs to be placed on our ability to counter the adversary’s destabilization campaign. Incorporating the concepts of *Dislocate* and *Isolate* (defeat mechanisms) and *Compel* (stability mechanism) will better enable the Joint Force to counter an adversary campaign plan.<sup>39</sup> These mechanisms are ways of exerting power and must be understood and developed in the context of the given environment and its unique power dynamics. See Appendix A (Counter Destabilization) for a detailed discussion on understanding and countering adversary destabilization efforts.

**4. How does the Army achieve military objectives throughout the competition continuum while simultaneously preserving or increasing the options to employ other elements of national power that will be required for a sustainable political outcome? Simultaneously, how can the Army enable other USG agencies to engage in stabilization efforts themselves throughout the continuum in order to set the conditions for stabilization success and leading to a satisfactory political solution?**

The Army's stability tasks all *contribute* to a desired end state condition for each stability sector, but *they are not sufficient by themselves* to achieve those conditions. Following the armed conflict period in Afghanistan and Iraq, the military (predominantly the Army and Marine Corps) found itself uniquely positioned to tackle stability-related issues. The military's physical presence, capacity, and ability to provide security gave it access across Afghanistan and Iraq that other departments and agencies did not possess. Combined with a predisposition for action, the military often assumed the leading role, even where it lacked capability. Although doctrine recognizes the importance of stability during all phases of the campaign, stability became synonymous with 'post-conflict reconstruction' and return to civil control. Singular stability actions became a short-term tool to weaken the insurgency instead of a synchronized long-term plan to consolidate gains.

Integrated campaigning requires synchronized efforts across multiple organizational boundaries; however, the structure of the USG makes interagency synchronization challenging. The JCIC proposes that commanders operate at multiple levels to best integrate military actions into a campaign.<sup>40</sup> The first



level is *psychological*. Every physical action (military and non-military) has psychological effects; therefore, the military contribution to a multi-domain battle campaign “must have an advantageous psychological impact on friendly, neutral, and adversary actors in the environment...founded on the coordination of military and non-military activities.”<sup>41</sup> A critical consideration is how actions by the U.S. military will impact local power dynamics. This impact may make it easier or more difficult to employ the other elements of national power. A second level is *political* – shaping and influencing efforts must be synchronized with non-Defense partners to achieve strategic outcomes if the overarching goal of military activity is to support USG policy aims. The third level is *logistical*. Integrated campaigns will generally be long duration, therefore, all elements of the USG must ensure that they can sustain their part of the campaign to support a partner as well as to weaken the adversary’s ability to sustain theirs. The final (and most traditional) level is *military*. Every action undertaken by the Joint Force must “shape favorable psychological, political, and logistical dynamics and conditions...in many cases in support of non-military activities.”<sup>42</sup>

The Department of Defense needs to reconsider its role with respect to stability during integrated campaigning in multi-domain battle. Since the Army is often the most visible manifestation of U.S. policy, it is imperative for the Army to “design and conduct campaigns to establish and maintain legitimacy of U.S. and partner actions while simultaneously discrediting, subverting, and/or attacking adversaries’ efforts to establish their legitimacy.”<sup>43</sup> Campaigns should continuously seek positional advantage for other elements of national power. One of the Army’s foremost objectives then must be to **establish, sustain,**

**and/or improve the level of security (military and civil) that is conducive to stability while operating in the policy space established by the USG, and continuously working to expand the space available for policy implementation without jeopardizing the legitimacy of the long-term USG integrated campaign.\*** This objective enables the maximum range of measures to absorb change, respond effectively as the intensity of the political situation changes,\*\* and is consistent with the JCIC's position that "the military instrument can rarely achieve sustainable strategic outcomes alone and is most effectual when applied in concert with non-military instruments in pursuit of clear political objectives."<sup>44</sup>

This objective is a more nuanced way for the Joint Force to frame its role with respect to stability, the stability sectors, and the joint stability functions during armed conflict and the return to competition phases. While the military's clear focus is the security sector, it also requires an intimate understanding of the Joint Force's impact across all stability sectors (especially the second and third order consequences of operational and tactical decisions). As learned in Iraq and Afghanistan, securing the environment only

\* The use of the term 'legitimacy' can be problematic due to subjective definitions. The use of legitimacy here is based on the discussion of legitimacy in JP 3-07: "Legitimacy is a condition based upon the perception by specific audiences of the legal or moral rightness of a set of actions, and the propriety as well as authority of the individuals or organizations taking them. Legitimacy reflects, or is a measure of, the perceptions of several groups, the local populace, individuals serving within the civil institutions of the HN, neighboring states, the international community, and, where the USG is involved, the American public." See Joint Staff, *JP 3-07 Stability* (Washington DC: The Pentagon, August 3, 2016), p I-15.

\*\* This idea is a combination of two separate points made in the JCIC. See page 20 (Campaigning in a state of competition below armed conflict), and page 18 (Alignment of Military and Non-military Activities - Military).

buys time and at best will provide a limited window of opportunity to address the root causes of the conflict through the remaining stability functions. The Joint Force will need to provide more than just security in order to maintain the legitimacy USG campaign.

To wit, during armed conflict and the return to competition, the Joint Force will be uniquely positioned in the operational environment to impact long term stability. It may be the only USG department or agency that is able to access local leadership, institutions, and facilities. Therefore, the Joint Force (specifically the ground forces of the Army and USMC) will play a significant role in future stability and the attainment of political objectives. A key consideration in this environment is the DoD's ability to conduct *transitional public security (TPS)*. TPS is executed to establish civil security and restore public order when the rule of law has broken down, is non-existent, or when directed by a high headquarters (see Appendix B, Transitional Public Security). Additional considerations include integrated civil-military efforts facilitated by Army Civil Affairs personnel to provide support to governance, foreign humanitarian assistance (FHA) efforts synchronized by DoD, restoration of essential services, and support to economic and infrastructure development. These are critical responsibilities that commands at all levels must plan for, and the Army must continue to develop and refine these capabilities within their specialized formations - Civil Affairs, Psychological Operations, and Information Operations, and conventional formations alike.

## Potential Stability “Traps”

Stabilization is not a silver bullet, nor will stability actions be equally effective, in every situation; however, like force posture, resilient formations, and convergence, stability is a critical component of the MDB solution. Understanding the stability-related “gaps” and potential “traps” within the multi-domain battle concept is essential to integrated campaigning in the future. These stability-related traps are deeply rooted in U.S. assumptions.

The term “cooperation” is generally associated with U.S. allies and partners, while the terms “competition” and “conflict” are used to describe relationships with adversaries and enemies. In reality, however, the boundaries between these three relationships are not always this black and white. The first potential stability trap within MDB is missed opportunities for cooperation and collaboration with potential adversaries because of a misplaced dividing line between along the competition continuum. A related trap is always assuming that allies and partners will be willing to cooperate. In reality, cooperation with adversaries is not as uncommon as it appears, while competition and even conflict with our allies and partners is becoming more common place. Examples of cooperation include Chinese anti-piracy efforts in the Gulf of Aden,\* and U.S.-Russia cooperation in the Arctic, particularly in and around the Bering and

\* Chinese anti-piracy efforts in the Gulf of Aden provide an example of how multiple relationships within the competition continuum can co-exist. While China’s contribution to the effort to combat piracy off the coast of Somalia is cooperation on one level, their establishment of a naval support base in Djibouti to support those operations certainly hints at competition on another level. See Matthew G. Minot-Scheuermann, “Chinese Anti-Piracy and the Global Maritime Commons,” *The Diplomat* (February 25, 2016). Accessed online at <https://thediplomat.com/2016/02/chinas-anti-piracy-mission-and-the-global-maritime-commons/> (accessed January 8, 2018).

Chukchi Seas. There are a number of examples of the opposite side of the coin to choose from: Turkey in Syria and Iraq, Pakistan in Afghanistan, and the Philippines in the South China Sea.

There are environments and situations where neutral actors and countries that are typically friendly towards the United States will not share the U.S. perspective due to their national interests – their goals and objectives may diverge from those of the United States. This makes understanding the environment and the relationship we have with allies and partners extremely important when it comes to stability actions and stabilization campaigns. Stabilization campaigns are not short duration, and the perspectives of partners and allies can and will change during the course of the campaign. The United States cannot take the national interests of partners for granted and assume alignment based on the existence of an alliance or partnership. Success in MDB will require a recognition of and understanding of these changes.

Proactive stabilization campaigns and counter destabilization efforts will typically be in support of a “host nation,” and the U.S. generally assumes that these host nations will be willing participants. Like the layers of cooperation, competition, and conflict described above, U.S. led stabilization activities may not be fully supported, and may lead to a situation where the U.S. wants stability more than the host nation does. Likewise, many in the U.S. assume that our definitions of and tolerance of stability and instability are shared by other actors. The United States (and to a large extent Western countries) have established a high standard for the term stability. Partners accustomed to different environment, many of which feature instability as a norm will not share the U.S. perspective – what appears to be instability

from the outside may actually be the norm for the local population. The 'acceptable level of instability' is not universal, and is always tied to culture and political legitimacy. Fixating on stability as a universal end state may blind the United States to opportunities. Getting to the 'last mile' on stabilization as defined by the U.S. may not be worth the cost or the risk, and may alienate natural allies such as humanitarian organizations who shun military-imposed security and stability.

Adversaries can also lead U.S. stability planners down the wrong road. Decision makers and planners tend to view adversary governments and leadership as unitary actors able to direct policy and achieve high levels of unified action. However, even autocratic governments will have different factions and personalities within the governance structures who compete for power and influence. The internal competition that occurs below the surface of any government may actually limit their ability to achieve political results even if they are successful militarily. Failure to recognize these fault lines could limit U.S. opportunities to present these adversaries with multiple dilemmas.

Finally, the U.S. must be attuned to conflict triggers that may not be associated with adversary actions. Too often the U.S. assumes that instability in a region is by design or occurs because of the deliberate actions of an adversary. Instability may be the result of extremely localized situations and may not have anything to do with outside actors. Local or national leaders may also exaggerate the role that an external actor is playing in their internal disputes in an effort to draw the United States into the conflict on their side. Understanding the source of the conflict and its impact on U.S. national interests is critical for integrated campaigning, especially as U.S. resources can be expected to decline.

## Conclusion

Stability is the common thread that weaves Multi-Domain Battle, the *Joint Concept for Integrated Campaigning*, and our national strategic documents together. The recently completed Stabilization Assistance Review (SAR), a joint effort lead by the Department of State, Department of Defense, and USAID concluded that “increasing stability and reducing violence in conflict-affected areas are essential to realize America’s national security goals and advance a world where nations can embrace their sovereignty.”<sup>45</sup> TRADOC’s Multi-Domain Battle concept is a key component of the Army’s role in this endeavor. By addressing stability actions across the competition continuum and not simply following armed conflict, the concept can pave the way for proactive stabilization and provide measures to counter adversaries’ destabilization efforts.

Stability is a foundational aspect of MDB, and is as critical to integrated campaigning as force posture, resilient formations, and convergence. Effective integration of stabilization into Army MDB efforts will require the Army to effectively support interagency-led efforts during competition to create and exploit windows of advantage by leveraging the authorities of its interagency partners. The Army must also be able to recognize the indicators of competition, and work with interorganizational partners to counter an adversary’s attempts to impact stability. When operating as part of the Joint Force, the Army must enable the political leadership to effectively converge diplomatic, informational, military, and economic forms of power. Finally, the Army must conduct operations in a way that at a minimum preserves options to employ the other elements of national power required to achieve political, and not just military, success.

A second conclusion from the SAR is that “effectively designing and pursuing stabilization are complex tasks involving many context-specific factors that are outside of a single actor’s control.”<sup>46</sup> Army leaders and planners must thoroughly understand the situation through multiple lenses and perspectives before embarking on a campaign. They must also constantly challenge long standing assumptions to avoid falling victim to them. Cooperation, competition, and conflict can and will co-exist on multiple levels and will change throughout an integrated campaign. Achieving stability is a two-sided coin that consists of ‘defensive’ measures to increase resilience and ‘offensive’ efforts to counter destabilization. While the Army and the Department of Defense may be the most expeditious department to tackle issues across the stability sectors throughout the conflict continuum, it is not the best equipped, and the Joint Force must ensure that its campaigns, operations, and actions do not limit opportunities for the employment of other elements of national power.

The task laid out by the 2017 National Security Strategy is to “ensure that American military superiority endures, and in combination with other elements of national power, is ready to protect Americans against sophisticated challenges to national security.”<sup>47</sup> The Multi-Domain Battle Concept, with stability as an integral component, will enable the Army and the Joint Force to do so.





## **Appendix A: Stability Targeting and Counter-Destabilization**

In the 2015 Army Posture Statement, Secretary of the Army John McHugh and Chief of Staff of the Army Raymond Odierno highlighted the “accelerating insecurity and instability across Europe, the Middle East, Africa and the Pacific, coupled with the continued threat to the homeland and our ongoing operations in Afghanistan”<sup>48</sup> as significant concerns to the United States Army. Many of the specific challenges they highlighted – the unforeseen expansion of ISIS and rapid disintegration of order in Iraq and Syria; the splintering of Yemen; anarchy, extremism and terrorism in North and West Africa; Russia’s intervention in Ukraine; China’s lack of transparency regarding its military modernization efforts; and North Korea’s nuclear and ballistic missile programs – continue to resonate today. McHugh and Odierno used the phrase ‘the velocity of instability is increasing’ to describe the operational environment faced by the Army and the Joint Force.

Nearly three years later, the United States’ capstone strategic documents – the National Security Strategy and the National Defense Strategy – acknowledge that the ‘velocity of instability’ is not only unabated, it continues to increase: “Today we are emerging from a period of strategic atrophy, aware that our competitive military advantage has been eroding. We are facing increased global disorder, characterized by a decline in the long-standing rules-based international order – creating a security environment more complex and volatile than any we have experienced in recent memory.”<sup>49</sup> In addition to transregional terrorism, the world is seeing the re-emergence of long-term, strategic competition between nations characterized by overt actions and efforts short of armed conflict that

challenge the “resilient, but weakening, post-WWII international order.”<sup>50</sup>

Our adversaries have two options when they seek to challenge the post-WWII international order. The first option is open military conflict in order to forcibly impose their norms globally or within a particular region. The tremendous risk associated with the potential political, economic, and military costs of this approach is driving adversaries towards a second approach. The second approach is to use all available instruments of power (some associated with national instruments and others not) to erode governance, rule of law, security, economies, and/or social well-being in order to convince a population that the existing norms no longer benefit them. In short, they target the stability sectors that underpin the fabric of society – why wage war when political objectives can often be achieved through the use of other instruments of power? By operating short of conflict, our adversaries “limit their exposure, avoid direct military conflict with the United States, and exploit their own areas of relative strength or advantage.”<sup>51</sup>

**If:**

- Targeting during Armed Combat focuses on targeting adversarial weapon systems and formations (military element of power), and...
- In order to operate below the threshold of Armed Combat, **adversaries must target something other than the military element of power**, and...
- Revisionist states seek to contest norms by convincing a specific population that those norms are not in their best interest by employing **Destabilization Narratives and activities that support and/or reinforce the narratives (examples):**
  - “Security is non-existent or not distributed equitably”
  - “Justice and Reconciliation is out of reach or serves the purpose of a particular group(s)”
  - “Basic human needs are not met, and social well-being is threatened”
  - “Governance is corrupt and/or dysfunctional with limited participation”
  - “Economic stability & infrastructure benefits are only for a select few”

**Then:**

- **The natural targets during competition become the five stability sectors: Security, Justice and Reconciliation (Rule of Law), Humanitarian Assistance and Social Well-Being (Essential Services), Governance and Participation, Economic Stabilization and Infrastructure**

Figure 7. Stability Targeting

The National Defense Strategy states that China asserts its “power through an all-of-nation long-term strategy” with the objective of gaining Indo-Pacific regional hegemony in the near-term and global preeminence by displacing the United States in the long-term.<sup>52</sup> China is not alone – Russia, Iran, North Korea, AQ, the Taliban, and other groups “although differing in nature and magnitude...compete across political, economic, and military arena, and use technology and information to accelerate these contests in order to shift regional balances of power in their favor.”

### **Critical Factors Analysis Approach**

To fully appreciate the foundational aspects of stability with respect to Multi-Domain Battle, it is helpful to view the stability sectors from an adversary’s perspective. Russia’s actions in Crimea and Ukraine provide contemporary examples of “how Moscow employs a combination of diplomatic, informational, military (both conventional and irregular), and economic means to achieve its aims. The precise mixture varies with the situation but seems calculated to achieve maximum effect without provoking a direct military response by the West.”<sup>53</sup> Russia’s use of Reflexive Control is a tool that leads an adversary to make decisions that benefit Russia. This mindset would have the Joint force expend the most effort on countering the adversaries more overt “constructed bait” while its destabilization actions attempt to present the Joint Force with a “fait accompli.”

Readers familiar with the Elements of Operational Design in JP 5-0 *Joint Planning* will be acquainted with the concept of Center of Gravity (COG) Analysis. JP 5-0 defines a COG as “a source of power that provides moral or physical strength, freedom of action, or will

to act.”<sup>54</sup> COGs consist of critical capabilities, critical requirements, and critical vulnerabilities. Together, these components are known as critical factors. Conducting a critical factors analysis for each of the five stability sectors – identifying those capabilities, requirements, and vulnerabilities that underpin security, governance, justice and reconciliation, economic stability, and social wellbeing – provides a unique perspective on potential ways and means that an adversary could employ to target stability in order to achieve its political objectives. Just as important, a thorough critical factors analysis can also demonstrate how the United States Army, the Joint Force, and the USG can counter an adversary’s efforts.

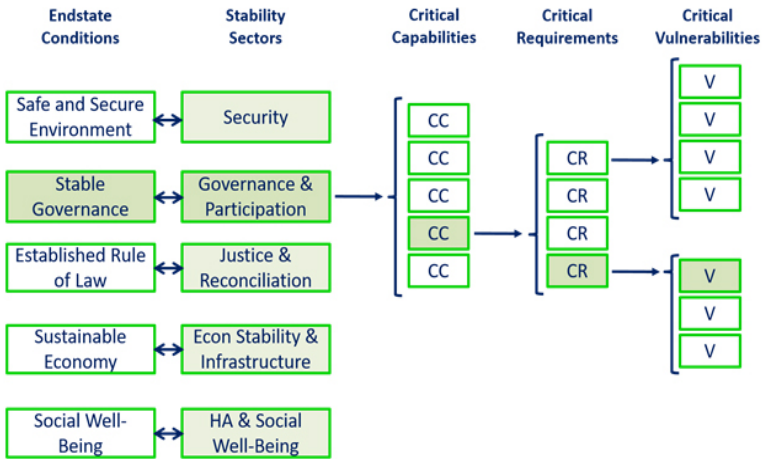

**Figure 8. Stability Sector Critical Factor Analysis (using Governance as an example)**

Figure 8 shows the linkages between COGs (in this case each stability sector), capabilities, requirements, vulnerabilities, and end state conditions. The five Stability Sectors provide the “moral or physical strength,

power, and resistance”<sup>55</sup> that enable governments and allow societies to prosper. Each stability sector is enabled by multiple **Critical Capabilities** which are the means considered to be crucial enablers for a stability sector to function effectively. Critical capabilities represent the “primary abilities which merits a center of gravity [in this case each stability sector] to be identified as such,”<sup>56</sup> and they are essential to achieving and maintaining the end state conditions associated with each sector. Each critical capability will have multiple **Critical Requirements** which are the essential conditions, resources, or means for a critical capability to be fully operative. **Critical Vulnerabilities** flow from the critical requirements. Vulnerabilities are the “requirements of components thereof which are deficient, or vulnerable to neutralization, interdiction, or attack (moral/physical harm) in a manner achieving decisive results.”<sup>57</sup>

Future competition and conflict will be unique to the region, the affected population, and the specific actors involved. Understanding specific vulnerabilities and how they relate to the requirements and capabilities associated with each of the stability sectors is a critical element when assessing the risk to stability in a particular state, region, or area. Understanding the vulnerabilities enables the USG to develop mitigation strategies for them, develop ways to reinforce requirements, and ultimately support capabilities to foster resilient stability functions. The critical factors analysis is one of the tools available to USG planners to better understand the competitive environment prior to developing and implementing solutions.

From an adversary’s perspective, these same vulnerabilities provide the entry points for stability targeting. By exploiting these vulnerabilities, adversaries can work to subtly undermine

requirements and capabilities with the ultimate aim of shaping the stability functions in ways that are advantageous to their interests.

## **Stability Targeting**

**Stability targeting** is a term that describes the actions an adversary takes to challenge stability, whether it is a single targeted sector, a combination of sectors, or stability writ large. States, non-state actors, and illegal armed groups all use or capitalize on instability to achieve objectives at all levels (tactical through strategic) by undermining U.S. influence, coercing or coopting power structures, or by manufacturing justification for additional action.

Stability targeting assumes that an adversary's end state objective is not instability. Rarely will long-term instability be advantageous to any party during competition, conflict, or the return to competition. The potential exception to this assumption is the criminal element of a hybrid force which thrives on uncertainty and insecurity. Stability targeting also assumes that an adversary has the ways and means to both generate instability and to regulate it. Adversaries will not attack stability with the intent of creating anarchy; rather they will use temporal instability to advance their interests or to hinder the progress of ours. Their long term objective will always be to regulate the functional systems of a conflict-affected area in ways that favor their own political national interests.<sup>58</sup>

To shape a stability sector, an adversary must apply their national resources in a measured and prioritized fashion that maximizes their chance of success while minimizing risk. Using the Ends-Ways-Means construct, the linkage between resources (means) and the vulnerabilities (initial targets that will ultimately lead

to a desired end state) are **destabilization approaches** (ways). Destabilization approaches are the conditions, tools, and/or actions that provide the ways to target critical requirements and critical capabilities when paired with resources (the means). The effectiveness of a destabilization approach is a combination of the resources applied to it and the weakness of the vulnerability or requirement it is applied against. To increase their effectiveness, adversaries can apply multiple destabilization approaches against a single vulnerability. Destabilization approaches are grouped into **destabilization mechanisms** which are analogous to the defeat, stability, and competition mechanisms found in U.S. doctrine and concepts, only they are specific to the adversary's effort.

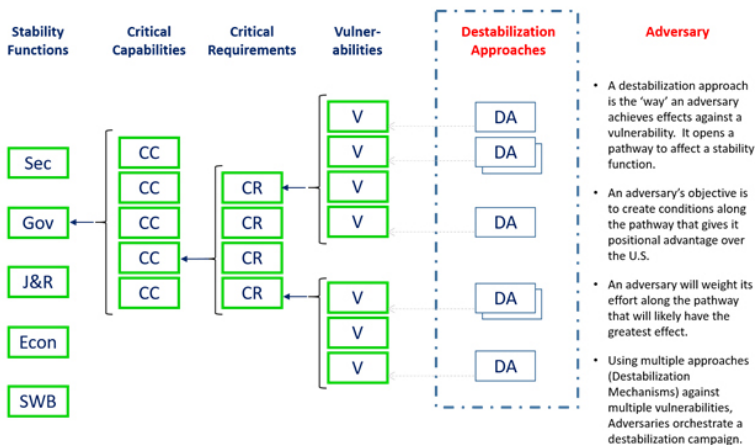
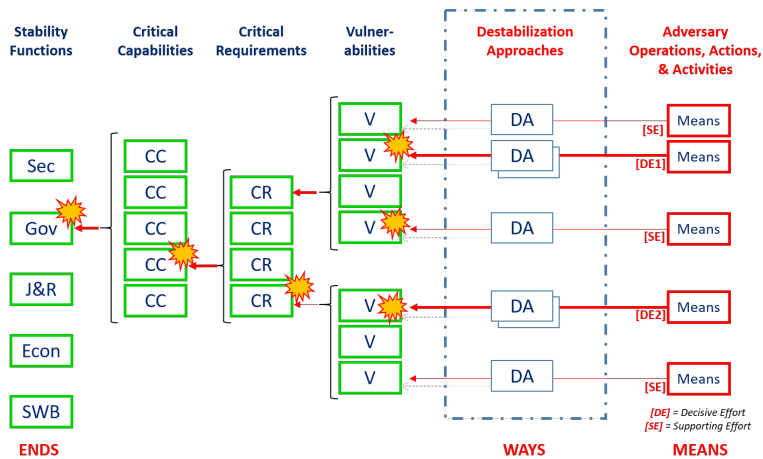

**Figure 9. Destabilization Approaches**

Not every vulnerability will have an associated destabilization approach. There may be vulnerabilities that an adversary cannot or chooses not to target because it lacks the required resources or because the available destabilization approaches are not feasible,



too costly, or pose an unacceptable amount of risk. The adversary's objective is to change the stability environment in a way that provides it with positional advantage. An adversary develops a campaign plan by identifying the key destabilization approaches that will open pathways to its endstate through the critical factors. Once identified, they can allocate resources to the pathways that will yield the greatest effect within a tolerable risk window. Figure 10 depicts adversary destabilization approaches prioritized by effort that together constitute a campaign plan. While the figure depicts actions along a single pathway (in this example governance), it will employ multiple instruments of power along multiple pathways to mitigate risk while achieving its overall objectives. As with any campaign, it can be adjusted over time to reinforce success and to shift resources (means) away from efforts that do not bear fruit.



**Figure 10. Adversary Destabilization ‘Campaign’ - Stability Targeting**

The non-military destabilization efforts that make up an adversary's campaign can and probably will be its main effort, while its more overt military or paramilitary actions will serve to mask its underlying objectives. By their definition, vulnerabilities (especially at the subnational level) are the farthest removed from the center of gravity and targeting vulnerabilities at the lowest level offers several advantages for an adversary. Critical vulnerabilities will often manifest themselves at the sub-national level. Sub-national vulnerabilities will be easier to target covertly or by using hybrid force proxies, enabling an adversary to operate under a cloak of deniability. Sub-national vulnerabilities will also tend to be less resilient to external pressure, making it easier for an adversary to influence actors and systems. Because they are less resilient, it will require fewer means to influence stability through them. As a result, an adversary can distribute resources along multiple pathways in an effort to achieve results.

The downside to targeting sub-national vulnerabilities is two-fold. First, this strategy is potentially a long-term approach. It will take time for sub-national effects to impact national-level decision making. Second, the second- and third-order effects of targeting at the sub-national level become more difficult to predict as the distance from the center of gravity increases. This in turn makes it more difficult for an adversary to regulate the resulting instability. An adversary could decide to target a critical requirement directly in an effort to achieve their objectives quickly and to exert more control over its target. This would require more resources, and potentially result in more visible intervention.

Gerasimov's "States of Conflict Development" (Figure 11) shows that stability targeting will take place throughout the competition continuum. It will be especially prevalent during the first three stages

(Origins, Strains, and Initial Conflicting Actions). It will also be important again in stage six (Post-conflict Regulation).

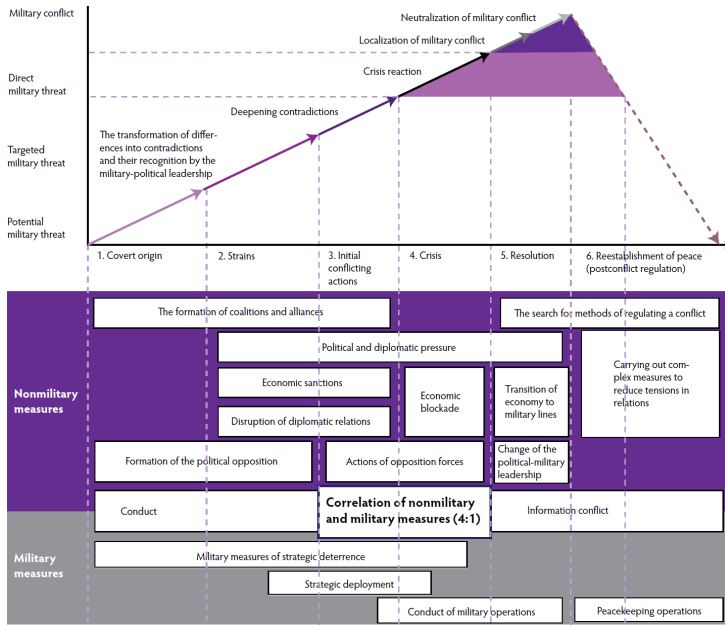

**Figure 11. Gerasimov's Stages of Conflict Development<sup>59</sup>**

## Counter-Destabilization

In response to the stabilization challenges the United States has faced, the United States Departments of State and Defense in conjunction with the U.S. Agency for International Development conducted the SAR to develop a framework to maximize the effectiveness of USG efforts. Their conclusion was not surprising: "The United States and our partners need a new and more disciplined approach for conducting stabilization in conflict-affected areas...an integrated civilian-military process to create conditions where locally legitimate authorities and systems can peaceably manage

conflict and prevent a resurgence of violence.”<sup>60</sup> This underscores the importance of stabilization as a critical U.S. capability throughout the competition continuum.

Understanding the vulnerabilities of an ally or partner is the critical first step when developing a campaign to support them through partnership. Between March 2003 and December 2011, the United States spent in excess of \$1 trillion on Operations IRAQI FREEDOM and NEW DAWN. A substantial part of the \$1 trillion plus was dedicated to stability and reconstruction. The United States supported the nascent Iraqi government by focusing efforts on improving capabilities, reinforcing requirements, and mitigating vulnerabilities. The results were not without flaws, but they were impressive nonetheless. With coalition support, the Iraqi government wrote a new constitution, established systems of governance, held elections, and formed a new government. However, support is only one side of the ‘operational coin.’

The objective of the United States was to cement the future relationship between itself and Iraq by supporting the development of Iraqi governance in the form of a democratic government. Minimizing Iran’s influence in Iraq was important, but subordinate to establishing the Iraq’s capability to govern. The United States employed the diplomatic, economic, and military elements of its national power to construct the “Iraqi Governance Building” one floor at a time. However, as the United States and Iraq added floors to the building, Tehran worked three or four levels below them to systematically dismantle what the United States achieved. Throughout OPN IRAQI FREEDOM and OPN NEW DAWN, Iran effectively leveraged its resources through multiple destabilization approaches to successful target vulnerabilities and change the stability landscape. Because the United States failed to effectively counter Iranian destabilization activities

within Iraq, Iran achieved long-term positional advantage. Instead of a strong U.S.-Iraq relationship with Iran marginalized in the region, the relationship that prospered was the Iran-Iraq relationship. And while the U.S. maintained a presence in the region (the U.S. Embassy with its Office of Defense Cooperation and then later OPN INHERENT RESOLVE), it was pushed to the periphery. Figure 12 (following page) demonstrates both sides of the 'operational coin.'

If support is 'heads,' then 'tails' represents an offensive capability to counter our adversaries' destabilization activities. **To prevent an adversary from achieving its objectives, the United States must be capable of both executing stability tasks that are part of a larger USG-led effort to support an ally or partner while simultaneously countering the efforts of an adversary to destabilize the institutions we are supporting.** Proactive stability consists of "hardening" or "strengthening" the stability sectors by increasing a country's resilience to destabilization. To strengthen the stability sectors, the United States must support critical capabilities, improve or reinforce critical requirements, and work with partners to mitigate their critical vulnerabilities. These are all important actions – they limit the effectiveness of an adversary's 'deconstruction efforts.' However by themselves, they are also insufficient.

In order to fully consolidate gains and transform initial military success into long term political stability, the United States must be able to counter an adversary's 'deconstruction efforts.' Counter-destabilization consists of countering the adversary's lines of effort, targeting their destabilization mechanisms, and by interdicting the means an adversary has to apply to their destabilization approaches. Figure 13 overlays proactive stability and counter-destabilization on the Targeting Stability model developed earlier.

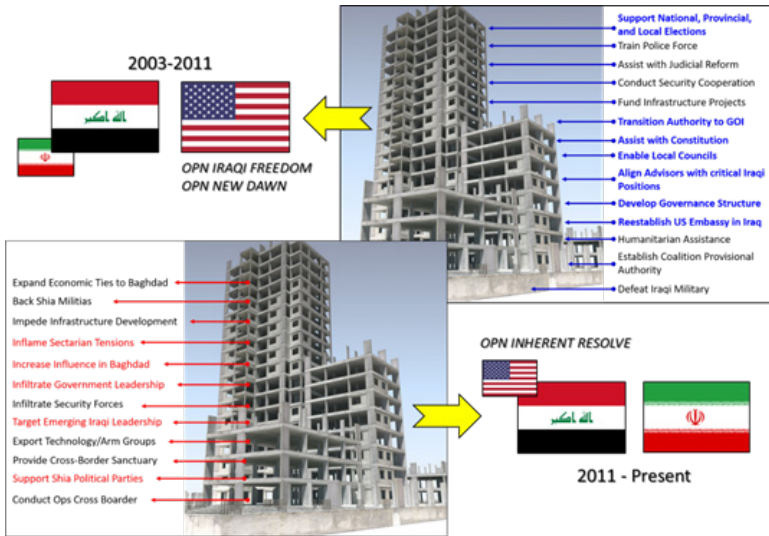

Figure 12. Two Sides of the Operational Coin

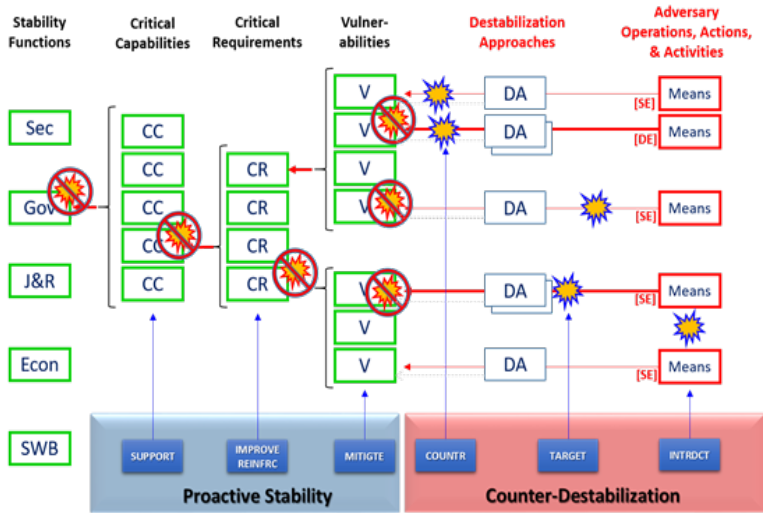
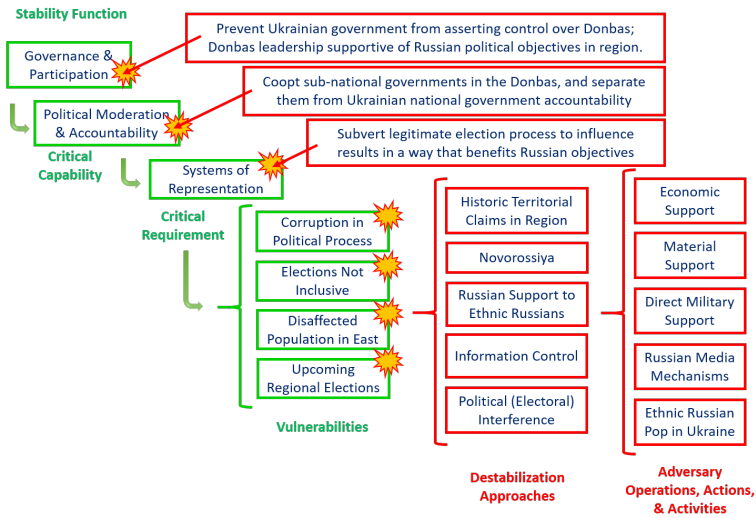

Figure 13. Proactive Stabilization and Counter Destabilization

The conflict in Ukraine offers numerous examples that can be applied here. Looking specifically at governance, a critical capability for effective governance in Ukraine is political moderation and accountability. The events leading up to Russia's annexation of Crimea demonstrate what happens with a lack of moderation and accountability. A critical requirement for political moderation and accountability is having effective systems that ensure political representation for the population. Equitable civil participation in the political process limits the extremes of government, and is the only way that a government remains accountable to its population. There are a number of vulnerabilities with any type of representative system, and examples in Ukraine include corruption in the political and electoral processes, elections that are not inclusive, and the presence of a disaffected population in eastern Ukraine (specifically in the Donbas).

The overall situation in Ukraine provides Russia with numerous destabilization approaches to choose from. The first is the concept of *Novorossiya* (New Russia), a historic term that the Ukrainian separatists in Donetsk and Luhansk today use to describe their would be autonomous or independent state. The second destabilization approach Russia uses in the region (and in other areas such as Georgia) is Putin's assertion that Russia will support ethnic Russians regardless of their location, even if it is outside Russia's current international borders. A third approach is to remind the world that Russia has long-standing historic links to and claims in the region. Russia has numerous resources that they can apply to their approaches. These include economic and diplomatic support to the Ukrainian separatists, material support, direct military support, access to Russia sympathizers in the Donbas, and energy resources. Control over the flow of energy

to Ukraine is another example of a destabilization approach that Russia could use to target the economic or social well-being sectors.



**Figure 14. Ukraine/Russia Example**

By targeting the vulnerabilities associated with Ukrainian systems of representation in the Donbas region, Russia has effectively coopted the election processes in Donetsk and Luhansk, and has installed leadership that is supportive of Russia’s objectives. This in turn has separated the regional governments in the Donbas from the national government in Kyiv. Since Kyiv no longer controls the two regions, Russia is free to act to further its objectives. Ultimately, Russia has paralyzed President Poroshenko, and has checked the eastward movement of NATO and EU influence, preserving its historic buffer area and sphere of privileged influence.

While the Joint Force will have a role in developing and implementing both proactive stabilization and counter-destabilization efforts, the overall campaign



must be orchestrated by the USG and support USG policy objectives. Borrowing concepts and terms from the *Joint Concept for Integrated Campaigning* and *JP 5-0 Joint Planning*, we can begin to develop a model that aligns effort with objectives for both sides of the operational coin. This also adds doctrinal rigor to the rather simplistic portrayal of the tasks associated with proactive stability and counter-destabilization in Figure 13. Figure 15 shows the relationships between the JCIC's Policy Aims, Competition Mechanisms, and Cooperative Relationships, and JP 5-0's Defeat and Stability Mechanisms. Mechanisms associated with Armed Conflict are in red, while mechanisms and relationships associated with competition and cooperation are in yellow and blue respectively. Some of the mechanisms apply to both competition and cooperation. 'Mitigate' is not listed in the JCIC as competition mechanism, but has an important role in proactive stability with respect to a partner's critical vulnerabilities.

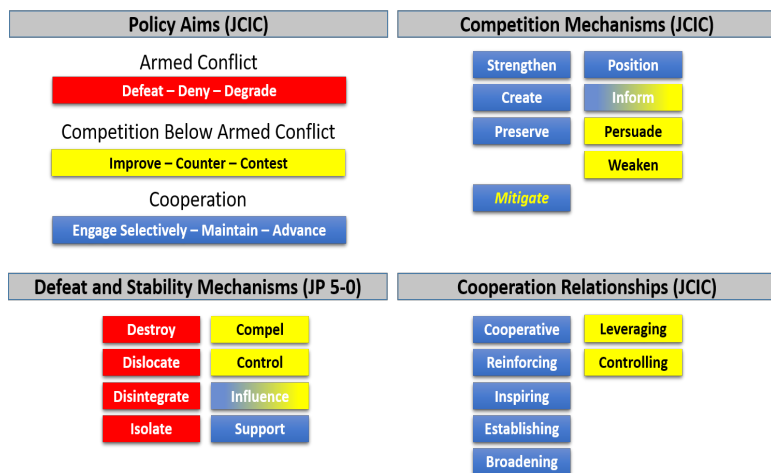

**Figure 15. Policy Aims, Mechanisms, and Relationships**

The JCIC divides the three states of relationships that make up the conflict continuum (cooperation, competition, and armed conflict) into sub-elements which form a range of policy aims to better articulate the relative intensity and trajectory of the relationships. Cooperation (blue) is characterized by efforts to engage selectively, maintain, and advance. Competition (yellow) consists of efforts to improve, counter, and contest. Armed Conflict (red) aims to defeat, deny, and degrade our adversaries. While there is significant overlap in some areas, the defeat, stability, and competition mechanisms can be generally aligned with the JCIC's policy aims.

Figure 16 overlays these alignments on the stability targeting diagram, and forms the beginning of an operational model that aligns policy aims with proactive stabilization and counter-destabilization activities described by the cooperation relationships, competition mechanisms, defeat mechanisms, and stability mechanisms. Proactive stabilization then becomes all of the activities designed to limit the effectiveness of the adversary's campaign and protect U.S. legitimacy, while counter-destabilization becomes the activities designed to increase the effectiveness and ensure longevity of the USG integrated campaign plan.

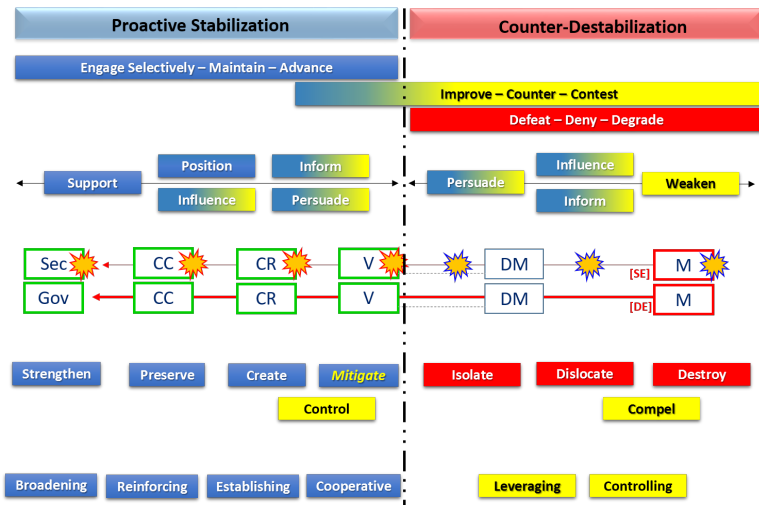

**Figure 16. U.S. Options for Proactive Stabilization and Counter-Destabilization**

Tables 1 (Proactive Stabilization) and 2 (Counter-Destabilization) on the following pages summarize the two approaches and provide additional doctrinal rigor to the process.

**Table 1. Proactive Stabilization**

<b>Policy Aims</b>	<b>Engage Selectively</b>	Transactional cooperation with the sole aim of achieving US objectives
	<b>Maintain</b>	Cooperate to maintain relationship and secure bilateral advantage without significant increase in resources or commitment
	<b>Advance</b>	Expand cooperative activities in the most appropriate manner it achieve U.S. aims while enabling or advancing partner interests
	<b>Improve</b>	Employ all measures short of those that might lead to conflict to achieve U.S. objectives.

<b>Mechanisms</b>	<b>Strengthen</b>	Develop alliances and partnerships and reward actors for siding with friendly forces (includes military engagement, security cooperation, favorable access/ trade)
	<b>Create</b>	Produce a condition where it does not already exist if its existence could positively impact achievement of national interests
	<b>Preserve</b>	Prevent deterioration of a stable situation (if ignored, could lead to challenge, or crisis)
	<b>Position</b>	Increase access, influence, and strategic understanding in the environment (includes intel activities, info exchange, rotational deployments, positioning of forward based capabilities).
	<b>Inform</b>	Develop shared perspective with partners, ID areas where cooperation would benefit both.
	<b>Support</b>	Establish, reinforce, or set the conditions necessary for the other instruments of national power to function effectively
	<b>Influence</b>	Alter the opinions and attitudes of the HN population through IRCs, presence, and conduct
	<b>Control</b>	Establish public order and safety; secure borders, routes, sensitive sites, population centers
	<b>Mitigate</b>	Take action to limit the impact of a critical vulnerability
	<b>Persuade</b>	Shape partner's objectives while remaining flexible in the pursuit of secondary objectives
<b>Relationships</b>	<b>Broadening</b>	Strengthen an established relationship
	<b>Reinforcing</b>	Support a partner's actions without taking the lead
	<b>Establishing</b>	Developing a relationship that is necessary to advance US national interests
	<b>Cooperative</b>	Working alongside willing partners with similar interests, partners interests align with US.

**Table 2. Counter-Destabilization**

<b>Policy Aims</b>	<b>Improve</b>	Employ all measures short of those that might lead to conflict to achieve U.S. objectives.
	<b>Counter</b>	Regulate competition to ensure the U.S. maintains its relative strategic position and competitor achieves no further gains
	<b>Contest</b>	Use prudent means to achieve the best possible strategic outcome within given resources or policy constraints
	<b>Defeat</b>	Create conditions to impose desired policy objectives upon the adversary
	<b>Deny</b>	Frustrate the policy objectives of the adversary
	<b>Degrade</b>	Reduce the adversary's ability and will to the greatest extent possible within resource and policy constraints
<b>Mechanisms</b>	<b>Inform</b>	Convey the limits of acceptability for a competitor's current or future behavior.
	<b>Influence</b>	Imposition of will on the situation through information operations, presence, and conduct to effect behavioral change through nonlethal means
	<b>Persuade</b>	Shape competitor behaviors while remaining flexible in the pursuit of secondary objectives
	<b>Compel</b>	Maintain the threat or actual use of lethal or nonlethal force to establish control and dominance; effect behavioral change; or enforce cessation of hostilities or settlements
	<b>Weaken</b>	Recognize, understand, and impose change in competitor's behavior using physical and informational aspects of power
	<b>Dislocate</b>	Compel the enemy to expose forces by reacting to a specific action
	<b>Isolate</b>	Limit the enemy's ability to conduct operations effectively by marginalizing critical capabilities or limiting the enemy's ability to influence events
<b>Destroy</b>	Identify the most effective way to eliminate enemy capabilities	

<b>Relationships</b>	<b>Leveraging</b>	Normally applied to actors who would align counter to US desired conditions/behaviors
	<b>Controlling</b>	Direct influence over an actor who would not normally be aligned with our desired conditions

The following three appendices examine stability targeting through the lens of three different entities: The Revolutionary Armed Forces of Colombia, the Islamic Republic of Iran, and the People’s Republic of China. These case studies were chosen specifically to examine a broad range of stability targeting approaches that include both state and non-state actors; local, regional, and global actors, and actions across a number of different stability sectors.



## **Appendix C: Stability Targeting Case Study The Revolutionary Armed Forces of Colombia: Targeting Governance and Social Well-Being**

**Hanna Smith  
Dickinson College**

For the purpose of this paper, *Las Fuerzas Armadas Revolucionarias de Colombia* or The Revolutionary Armed Forces of Colombia (FARC) was selected as a case study to exemplify non-state stability targeting. During both the height of FARC's operations in the 1980-90s and their decline towards the peace accords, FARC utilized destabilization mechanisms across all sectors, with a focus on social well-being. Though often portrayed as a delinquent insurgency operating solely on drug money and kidnapping, FARC maintains the self-image as a political movement rather than a terrorist organization.<sup>61</sup> For this reason, their operations extended beyond violence to include social welfare for rural Colombians. Throughout its struggle, FARC leadership has consistently advocated for alternative crops to coca production and the rights of poor unemployed Colombians: in essence, a peasant uprising similar to those seen throughout Latin American history. The difference, however, lies in the strategic and tactical paramilitary innovations developed by the FARC. Destabilization operations were the fundamental instrument that allowed the FARC to be a prominent influence in Colombia for so long.

For half a century FARC was the most dominant sub-national group in Latin America. The Marxist guerrilla movement evolved from a small rural operation to a complex and militarily advanced movement.



In 1997, FARC was designated a Foreign Terrorist Organization by the United States Department of State, recognizing the threat posed to regional stability.<sup>62</sup> The 2016 Havana peace talks successfully negotiated a ceasefire agreement and the projected disarmament of the FARC, however, the future of the organization remains uncertain. Despite the peace accord, certain blocs continuously instigate instability in the hopes of antagonizing the Colombian state. Additionally, spoilers ingrained in the narcotics trafficking industry see little incentive to terminate their lucrative business operations. Those guerrillas embedded in the narcotics industry seek out instability as an end state to facilitate their illicit business rather than as a political means like FARC leadership. The faltering demobilization process suggests that the peace process will not be without difficulties.<sup>63</sup> Nevertheless, the persistence and struggle of the FARC remains one of the most significant movements in Latin America and should continue to be examined to enhance our understanding of U.S. national security.

On May 27, 1964 the guerrilla insurgency was founded with the goal of establishing a Marxist government in the state of Colombia. Since then, FARC has continued their long tradition of insurgency, employing both criminal and terrorist tactics to destabilize the Colombian state.<sup>64</sup> FARC's social sector destabilization operations have been successful largely due to the geopolitical disposition of Colombia. By supporting the rural areas that lack infrastructure and non-agricultural industry, and those that were typically beyond the reach of or ignored by the central government, FARC was able to acquire regional control and support.<sup>65</sup> This fragmentation of the Colombian state was then exacerbated by criminal activity, creating chaos and government turbulence.<sup>66</sup>

For this reason the FARC has survived for decades, eventually becoming the last remaining guerilla war in the Western Hemisphere.

The FARC political doctrine originated from the pro-Soviet Communist Party of Colombia (PCC), and its guerrilla doctrine from Mao's Protracted People's War, which emphasizes the combination of all forms of struggle.<sup>67</sup> Unlike many liberal-democratic states, FARC has remained steadfast in their long-term strategic goals.<sup>68</sup> FARC leadership goes through extensive training and education to ensure a single strategic mentality is implemented.<sup>69</sup> Nevertheless, FARC remains flexible enough to adapt to the changing environment in order to apply the proper correlation of forces.<sup>70</sup> The 1982 Seventh Conference established the following goals for the modern FARC: 1.) Consolidate control of the coca-growing regions of Colombia 2.) Expand areas of operation to control strategic smuggling corridors and force the Colombian army to spread-out and overextend 3.) Isolate Bogota from the outside world and 4.) Move to large-scale offensive operations.<sup>71</sup> This offensive strategic plan would later change to a defensive strategy to account for the aggressive counterinsurgency and counternarcotics campaign by the Colombian government.

The Colombian government has failed to negotiate a peace deal with the FARC numerous times. Colombia remains in a cycle of conflicts fought almost to victory, "but then concluded with a bad peace deal that set the conditions and causes for the next round of conflict."<sup>72</sup> It wasn't until 2016 that both parties came to a final agreement. However, many observers question the sustainability of the final accord because of the generous concessions made by Colombian negotiators.<sup>73</sup> Similar to past attempts at peace, the FARC is already facing challenges in the demobilization process. For this

reason, “it is almost easier to revert to war than to continue to attempt to build peace.”<sup>74</sup>

The following case study will examine FARC’s use of destabilization approaches to target critical vulnerabilities within the social well-being and governance sector as well as the security sector. By targeting the Colombian government’s control over critical requirements for stable governance such as core service delivery and political moderation and accountability as well as security through the legitimate state monopoly on violence, cessation of large-scale violence and physical security, FARC was able to successfully destabilize Colombia. Stability targeting using non-military elements of power comprises the majority of FARC’s operations with sub-national violence employed to exacerbate political chaos. By implementing stability targeting FARC sustained a half-century protracted civil war.

## **Social Well Being and Governance**

What sets the FARC apart from other sub-national groups in the region is their effective use of stability targeting against the social and governmental sectors. According to the United States Institute of Peace and the U.S. Army Peace Keeping and Stability Operations *Guiding Principles for Stabilization and Reconstruction*, Social well-being is defined as the ability of the people to be free from want of basic necessities and to coexist peacefully in communities with opportunities for advancement.<sup>75</sup> In the Case of the FARC, many guerrillas joined as a means of voicing their dissatisfaction with the failing Colombian state. The government’s inability to provide for poor coca farmers in the Eastern Plains, Cauca, Valle del Cauca, and Nariño regions is a major driving force for FARC’s supporters. This,

in combination with stable governance --the ability of the people to share, access, or compete for power through non-violent political processes and to enjoy the collective benefits and services of the state-- are FARC's primary targets.<sup>76</sup>

By supporting the rural poor in areas where the Colombian government has failed to provide basic services, FARC controls the narrative and acts as a pseudo-state. When Manuel Marulanda Velez founded the FARC in 1964 his stated objective was to "overthrow the ruling order in Colombia and drive out what it perceived to be U.S. imperialist interests from Latin America, while simultaneously establishing a Marxist or at least a socialist government."<sup>77</sup> FARC's refusal to accept the Colombian government and renounce violence is the central vulnerability that inhibits the state's ability to manage conflict. While their tactics evolved, the ultimate objective of seizing power has remained consistent throughout FARC's struggle.

By using both legal and illegal methods of coercion FARC demonstrates the "correlation of revolutionary and government forces," to advance the combination of all forms of struggle.<sup>78</sup> This basic doctrinal principle parallels stability targeting within the competition continuum of a protracted war. FARC participates in elections while simultaneously applying violence and terrorism to subvert the Colombian state.<sup>79</sup> After provoking government instability, FARC presents communism as the more effective and affluent government.<sup>80</sup> As a political organization, FARC is motivated by revolution and recognizes the importance of political activity "backed up by massive violent and semi-violent social protests, funded by drug trafficking."<sup>81</sup> By targeting the democratic process in Colombia, FARC further delegitimizes state political moderation and accountability. Nevertheless, FARC

lacks the popular support in Colombia to establish a significant political holding.<sup>82</sup> For this reason, stability targeting is their only means of influence within the democratic government.

Prior to the peace agreement, FARC's primary destabilization approach was delegitimizing the state by presenting themselves as the more competent power. Not only did FARC become one of the wealthiest subnational groups in history, but they also established a tax system, developed infrastructure, mediated disputes and provided basic social services. By replacing the state in the role of core service delivery during times of instability, FARC legitimizes their claim to power in the regions they support.

Despite accusations of being a drug trafficking organization, FARC maintains their position as a political movement. FARC spokesman Rodrigo Granda contends that they are "an organization with clear political proposals and that is why the Colombian government feels obligated to sit down and negotiate with [them]."<sup>83</sup> However, as the young FARC leadership transitions into power it is evident they are not as committed to the Marxist rebellion as their predecessors. The lure of profit from narcotics trafficking and other illicit activity has detracted from their revolutionary goals.<sup>84</sup> A critical requirement for the success of the peace process is the management of spoilers. This will continue to be a challenge to FARC and Colombian leaders looking to end the war during the disarmament process and transition towards peace.

Actions such as providing poor farmers with social services while also using terrorist tactics to undermine government stability exemplify application of stability targeting. The FARC will, "present itself during a time of chaos, disorder, and havoc as a better alternative than the existing government structure."<sup>85</sup> Now, as the FARC

demobilizes, their ideological motives will transition from a military doctrine to a political platform.<sup>86</sup> The Havana peace agreement obligates the Colombian state to consult with minority social movements such as the FARC while creating and implementing public policy.<sup>87</sup> Moreover, FARC guerrillas are guaranteed a minimum of five seats in both the House and Senate of the Colombian legislature despite their lack of support from the greater Colombian population. This is a triumph in FARC's long struggle for political representation and control. Though the civil war has come to an end, the FARC ideology will continue to be a significant movement in Colombian politics, a testament to the strength of the stability targeting operations within the social sector.

## **Physical Security**

When evaluating stability targeting operations, the most visible and damaging approaches are within the security sector through politically motivated violence. Because it is a designated terrorist organization, analysis of FARC's violent activity is important to the overall understanding of the organization. FARC utilizes violence as an extension of their political agenda. The *Guiding Principles* defines Security as the ability of the people to conduct their daily lives without fear of systematic or large-scale violence.<sup>88</sup> The Department of Defense further describes security sector operations as efforts that focus on developing legitimate institutions and infrastructure to maintain stability, protecting civilians, and restoring territorial integrity.<sup>89</sup> Within the security sector, the cessation of large-scale violence, the legitimate state monopoly over violence and physical security are the primary critical requirements targeted by FARC.

For the past 50 years, FARC has consistently applied violence as a means of obtaining their goals. Initially, this was limited to ambushes of military units and farm raids to obtain supplies for survival.<sup>90</sup> However, by the 1980s FARC transitioned to offensive tactics through assault, ambush, sabotage, assassination, and kidnapping. Today, Colombia has one of the highest homicide rates in the world with 30,000 annual murders.<sup>91</sup> This violence is magnified by illicit drug trafficking, as cartels and gangs fight for dominance of critical plazas.

In the late 1990s, FARC's massive military expansion provided them with the capacity to inflict substantial casualties and damages on the Colombian state. By threatening the physical security of Colombia, FARC created further instability already in progress from its political actions. FARC grew from its original 350 guerillas to 15,000-20,000 at its peak.<sup>92</sup> To address the influx of guerillas, they established seven territorial blocs, each with anywhere between 4-20 fronts.<sup>93</sup> FARC's substantial bureaucratic structure enhances their capacity to strategically inflict violence. Blocs often resort to violence and kidnapping as a means of raising funds for the secretariat. These severe human rights violations make FARC a security threat for the region and world as a whole.

Tactical violence can be divided into four categories: terrorism, guerilla warfare, mobile warfare and positional warfare.<sup>94</sup> FARC has continuously employed combinations of these forms of violence to successfully undermine Colombian peace. This set the foundation for one of the highest attack rates in the world. For example, in 2011, 79% of all terrorist attacks in the Western Hemisphere were attributed to FARC.<sup>95</sup> For the FARC, tactical violence is used with the goal of achieving one of two goals. The first is to protect the



traditional agricultural lifestyle and source of income of the cocaleros. The cocaleros are rural Colombian farmers who make a living on cultivating the Coca plant used for cocaine production. With the implementation of aggressive counternarcotics operations by the US and Colombian governments, the cocaleros turned to FARC for support of their cause. By portraying FARC violence as a “struggle for long-suppressed indigenous rights” they gain sympathy and thus, “confronting the Cocaleros became politically incorrect.”<sup>96</sup> The second is to incite violent social protests that force the police to react.<sup>97</sup> This is especially significant in the aftermath of the peace accords. Though the Colombian government is obligated to allow minority representation, “there is nothing in the accords about the responsibilities of social movements to operate within the law, or to respect the rights of non-protesters.”<sup>98</sup>

The various forms of violence employed throughout their struggle enabled FARC to generate fear and instability in Colombia. After 50 years, the casualties in Colombia totaled 220,000 dead, 25,000 disappeared, and 5.7 million displaced.<sup>99</sup> FARC’s most notable acts of violence include the abduction of presidential candidate Ingrid Betancourt (2002), assassination of the Colombian Cultural Minister (2001), and the hijacking of a domestic commercial flight (2002).<sup>100</sup> Today, one of the most pressing vulnerabilities for Colombia in the post-FARC era is dismantling the land mines around the country to prevent further civilian casualties.

FARC’s reliance and investment in violent activity made it, “mentally and physically difficult to switch gears.”<sup>101</sup> By the end of their dominance in the Colombian countryside, it became evident that the FARC had lost sight of their strategic objectives and socialist end state. Doctor David Spencer argues that, “to transition to a war of movement, expanding beyond



the bounds of the rural periphery where it could rely on local support” was the fundamental strategic error of the FARC insurgency.<sup>102</sup> Though FARC’s stability targeting operations involved the security sector, its greatest successes in gaining momentum and popular support was in the social and governance sector.

## **Conclusion**

The Revolutionary Armed Forces of Colombia demonstrate the cross-sector application of security targeting. It is important to note that, while social well-being and security are FARC’s primary targets, their approaches are not limited to these two sectors. With a narcotics industry so substantial and profitable that it impacts the international economy, FARC maintains economic mechanisms for destabilization. Moreover, threats to the judicial system and the notorious “plata o plomo” (silver or lead) approach permit FARC and its associated cartels to continue their operations outside of the law. By implementing stability targeting within each of the stability sectors, FARC dominated Colombia for an unprecedented five decades.

FARC was selected for this case study as an example of non-state stability targeting. However, as I have demonstrated throughout this case study, the actor in question- whether they are non-state or state- implements stability targeting with the intention of monopolizing stability. FARC instigates instability within the Colombian state to demonstrate their superior control over the security and governance of Colombia. This is a common thread seen between each of the case studies. Instability is not the end game, but rather a way to an end. In the case of the FARC, stability targeting led to the successful attainment of political representation within the Colombian state. Although

it is still early in the peace process, this representation promises change to the social structure of Colombia. The case of the FARC is an underrepresented example of the power of stability targeting. Not only was the FARC able to maintain a protracted civil war for 50 years, acquire tremendous wealth and gain political power, but they also obtained substantial political support from many rural Colombians. By examining FARC's approaches to destabilization, we are better equipped to deal with violent social movements and gain a valuable understanding of the social sector.



**Appendix D: Stability Targeting Case Study**  
**The Islamic Republic of Iran:**  
**Targeting the Security Sector**

**Nicholas Hargreaves-Heald**  
**The Fletcher School of Law and Diplomacy**

Since the Islamic Revolution of 1979, the Islamic Republic of Iran has proven to be a resilient and highly motivated U.S. adversary in the realm of stability targeting operations across multiple domains. Iran, a nation home to some 82 million citizens who are overwhelmingly (some 90-95%) Shi'a Muslim, has been ruled since 1979 by a radically anti-Western Theocratic regime.<sup>103</sup> Over the past thirty-five years, Iran has sought to weaken Western influence across the globe, while simultaneously increasing the standing of the Islamic Republic, Shi'a Muslims, and (ostensibly) the entire Muslim *umma*. In order to do so, Iranian operations (led by elite Iranian special operations Quds Force) have used proxy Shi'a militant and terrorist groups to target the stability of almost half a dozen nations spanning multiple theaters and several continents. These nations are known to include Lebanon, Iraq, Yemen, Bahrain, Kuwait, and Saudi Arabia; and Iran continues to mature and develop relationships with groups in South America, Eurasia, and Asia.

These operations frequently target the Governance and Social Well-Being stability sectors, in which Iranian proxy forces compete for political legitimacy in the hearts and minds of Shi'a (and some Sunni) populations in target nations. The majority of Iranian operations, however, target the Security stability sector. In this case study, we will focus entirely on Iranian efforts to attack critical vulnerabilities in the Security stability sector, which allow them to erode critical requirements and thus break down four critical capabilities of the

security sector. To provide adequate context, we will briefly explore each critical capability within the Security stability sector, and highlight a few key points pertinent to the Iran case study before providing an overview of four Iranian stability targeting operations.

*Legitimate State Monopoly over the Means of Violence:* It is critical for a government to maintain a legitimate monopoly over the means of violence within a state. Most stable, developed nations, possess clear legal safeguards, historical precedent, and public acceptance demanding the state's monopoly over the means of violence. However, many developing nations face ambiguous legal or historical precedents, fractured support of the government's legitimacy, and armed groups competing for political legitimacy and public approval of their use of violence. A destabilizing actor, therefore, need only erode the public's perception of the *government's* legitimacy and unanimous right to use violence by introducing or supporting an armed group which can compete with the government for politico-military power. If executed well, competing forces can undermine the government's legitimacy, challenge the state's monopoly over the use of violence, and force citizens to reconsider their consent to the social contract with their government. The result is often a radical power imbalance within a state, leading to competing armed entities and possibly civil war.

*Physical Security:* Civilians, infrastructure, public facilities, and key symbolic sites such as historical or cultural landmarks must be made secure from grave danger in order for a state to be made secure. Protecting the physical security of its citizens is also a key responsibility of governance, and is therefore required for the government to be considered legitimate in the eyes of the population. Should a government fail to protect its citizens, its legitimacy will suffer and citizens will begin to look for other sources of protection.

*Territorial Security:* In order for a nation to be secure, the territory of the target nation must be secure for citizens and goods to move freely within and across borders – and for illicit individuals and products to be denied free passage. This relies on both border security and freedom of movement for citizens and goods. The significance of these factors is also affected by the direction of military featured in the nation: if a military is focused on protecting against external threats, border security is likely to be a more significant concern that receives greater attention; should a military be focused against internal threats, however, it is far less likely that border security will be a stable, primary interest. In many regions of the world, however, geographic characteristics make securing a nation’s borders either impossible or extremely taxing. For this reason, many developing nations who do not have the economic, political, and military infrastructure and resources necessary to do so face the challenge of porous borders which allow for illicit materials to enter and exit undiscovered. Additionally, many states feature complex demographic landscapes, where geographic spaces are integrally linked to particular identity groups. In these circumstances, any conflict between identity groups can significantly reduce the freedom of movement for all groups across state territory. Consequently, the geographic *and* human terrain of a state can provide serious vulnerabilities, which adversaries can exploit to destabilize the target nation’s territorial security.

*Cessation of Large-Scale Violence:* Finally, violence must be reduced to a degree where a peace process can take place, an agreement can be reached, and a nation made secure. Violence, however, can take place as a result of both intentional action *and* the Clausewitzian friction inherent to all conflicts. The continuation of violence, therefore, is easily facilitated by both active and passive encouragement. Such

active encouragement can consist of executing or commanding direct action; but passive encouragement may merely be as simple as condoning safe havens or turning a blind eye to violent groups. Either type can greatly inflame violence and reduce the chances for a successful peace process.

### **Iranian Stability Targeting, 1979-2018**

Iran's primary tools for eroding security in a target nation involves the development of armed Shi'a groups or cells in the target nation, which it then commands or encourages to undermine certain critical capabilities of the target nation's Security sector. Typically, Iranian destabilization approaches consist of enabling these groups to: challenge the government's legitimacy and monopoly on the means of violence; continue the conflict and prevent a peace process; accentuate violence and general insecurity in the target nation; introduce large numbers of weaponry and live ordinance to the conflict zone; inflame sectarian resentment with sectarian reprisals; overwhelm a border defense force's capabilities; and make cross-border attacks. In order to be able to make these approaches effective, Iran seizes upon mechanisms such as Shi'a unity and expansionism, desire for an Islamic government, and anti-Western and anti-Israeli sentiments. By utilizing these mechanisms, Iran can gain the cooperation of various armed groups and proxy forces, and thereby use them to erode stability in a target nation without bearing direct responsibility.\*

\* It should be noted that Iran also support some Sunni groups in Iraq and Syria. Although these groups are few and far between, Iran's relationship with such groups depends on an alignment of geostrategic goals, such as anti-Western and anti-Israeli sentiments. Based on these shared goals, Iran also markets itself as a vanguard fighting against the West to the entire Islamic *umma*.

Iran's often targets more than one critical capabilities of the security sector. In order to delve more deeply into individual components of each Iranian stability targeting operation, this case study will examine each operation through the lens of a single critical capability in a unique conflict.

### Lebanon, 1982-2006 (Legitimate State Monopoly over the Means of Violence)

When Iran targets security, its primary goal is almost always to erode an existing government's legitimate monopoly over the means of violence, primarily by creating an armed group which can compete for legitimacy in the eyes of the population. The armed group also functions as a force extender, allowing Iran to attack primary adversaries such as the United States and Israel.

Iran's first operation of this type (and also their most successful and famous) began in Lebanon in 1982. That year, a group of Lebanese Shia militants founded the insurgent-terrorist movement Hezbollah (now a U.S. designated terrorist organization) at the behest of Iran's Supreme Leader Ayatollah Khomeini.<sup>104</sup> From 1982 on, Hezbollah engaged in a brutal insurgent and terrorist campaign against Israeli and Western forces in Lebanon. Their fight was only possible due to their harmonious relationship with Iran, which provided them with thousands of IRGC military and political advisors; Iranian made firearms, sniper rifles, AGRMs, and rockets; political, religious, and ideological motivation; and an estimated average \$150-\$200 million per year.<sup>105</sup> This support was so extensive that it enabled Hezbollah to wage a nearly forty-year campaign against the West (including a guerilla war with the IDF from 1982-2000 and again in 2006, decades of kidnappings, hijackings, suicide and



conventional bombings, raids, and rocket attacks that continue today) and led the organization to become viewed by the Lebanese people (and many Arabs) as both a champion of the anti-Israeli cause *and* the legitimate defender of the Lebanese people.

By 2006, Hezbollah and Iran worked so closely with one another that most authorities considered the two to be one in the same: Hezbollah was merely an extension of the Iranian state in Lebanon. Yet, in Lebanon, Hezbollah earned official status as a legitimate Lebanese political party<sup>106</sup>, and their military wing (formally recognized as a “resistance movement” by the Lebanese government) gradually came to dwarf the Lebanese army. The result was both a security and legitimacy crisis for the Lebanese government: Iran, through Hezbollah, had a considerable majority over the means of violence in Lebanon (in addition to a popular reputation as the state’s legitimate defender), and therefore wielded power equal to, if not greater than, the state political system. Although Lebanon avoided civil war by embracing Iranian Hezbollah, the instability in the security system of Lebanon caused some experts to correctly identify Hezbollah as a “state within a state”.<sup>107</sup> In effect, this conflict of power not only allowed Iran to destabilize Lebanon’s security sector, but also to challenge its entire system of governance.

#### Iraq, 2003-2011 (Physical Security)

During the Iraq War of 2003 to 2011, Iran exploited and developed ties with violent, anti-Western Shi’a groups in order to undermine security in Iraq. Primarily, Iran connected with these groups following a familiar pattern: exploit a common Shi’a identity, the Islamic Republic’s religious authority (especially that of the Supreme Leader), and shared anti-western

sentiments to recruit these groups as proxy forces fighting under the banner of the Islamic Revolution. At the forefront of this relationship was the Iranian Quds Force, which was responsible for all Iranian or Iranian-backed activities in Iraq. As early as 2003, Quds Force arranged for Lebanese Hezbollah to begin training a violent, anti-Western Shi'a group in Najaf, Iraq.<sup>108</sup> From 2004 on, such operations continued in Iraq and expanded to Iran, where IRGC and Hezbollah members trained a menagerie of Iraqi Shi'a militant and terrorist groups (which would eventually become known as "Special Groups"), and then sent them back into Iraq to carry out attacks. By mid-2004, Iran had established an elaborate smuggling operation, which introduced increasing numbers of advanced weaponry and live ordinance into Iraq, including materials for IEDs and Explosively Formed Penetrators (EFPs).<sup>109</sup>

In the years that followed the number and sophistication of the special groups operating in Iraq (including Asa'ib Ahl al-Haq, Kata'ib Hezbollah, Liwa al-Youm al-Mawud, Badr Brigade, and the Sheibani Network<sup>110</sup>) grew, and Iranian support expanded. By 2005, such support included direct financial contributions of an estimated \$9 to \$36 million per year<sup>111</sup>, hundreds of small arms and advanced weaponry such as large-caliber sniper rifles, dozens of tons of explosive material<sup>112</sup>, ideological and political motivation<sup>113</sup>, advanced tactical and operational training from IRGC and Hezbollah operatives, and indirect strategic guidance from Iranian Quds Force.<sup>114</sup> With this support in hand, Iranian Special Groups waged a brutal insurgent and terrorist campaign against U.S. forces, Iraqi security personnel, and militant and civilian Sunni groups. From 2005 (when the Special Groups started fully fledged operations) to 2011, anti-government and anti-coalition violence

caused almost 15,000 Iraqi civilian deaths<sup>115</sup>, over 3000 coalition fatalities<sup>116</sup>, and a state of abject chaos across much of Iraq. By 2007, over two million people had fled Iraq, and almost the same number were internally displaced as a result of the violence.<sup>117</sup> Throughout this time, Special Group forces also attempted numerous kidnappings and assassinations of Iraqi politicians, which eroded the security of the U.S.-backed political leadership in Iraq.

Iran's operations were specifically intended to erode Iraq's civil security. Their support of Iraqi Special Groups clearly created conditions of instability and insecurity within Iraq which threatened the safety of the general population and Iraqi political leadership. Moreover, Iran's smuggling operations introduced incredible numbers of live ordinance into Iraq,<sup>118</sup> including materials for building thousands of IEDs, hundreds of EFPs featuring passive infrared sensors, dozens of 122mm Grad and 240mm Fajr rockets, rocket propelled grenade launchers, and 60mm and 81mm IRAM mortars.<sup>119</sup> This ordinance killed over 200 U.S. soldiers, injured some 800 more, and greatly decreased the physical security of civil society within Iraq.<sup>120</sup>

Additionally, Iran undermined Iraq's physical security by launching a major campaign of deadly reprisals against Iraqi ex-combatants: from 2003 to 2009, Iranian Quds Forces or proxy forces assassinated over 180 Iraqi Air Force officials<sup>121</sup> and dozens of former Intelligence officers who had participated in the Iraq war of 1980-1988.<sup>122</sup> Iranian Special Groups also executed extended campaigns of sectarian reprisals against Sunni Iraqis, which have created conditions of real and perceived danger for the Sunni minority in Iraq. These campaigns have included thousands of killings, and hundreds of kidnappings<sup>123</sup>, bombings, and forced relocations.<sup>124</sup> Whether Iranian officials

encouraged such reprisals is unclear, though such attacks would align with their strategic goals. Either way, Iranian Special Groups have acted as the vanguard for the increasingly violent sectarian war in Iraq<sup>125</sup>. Their reprisals (along with those of the Sunni militias they are fighting) and ex-combatant assassination campaigns have greatly eroded the security of the vulnerable populations in Iraq.

#### Bahrain, 2011-present (Territorial Security)

Following the failed uprisings of the 62% Shi'a majority<sup>126</sup> in Bahrain, Iranian officials began a serious covert operation to destabilize the territorial security of the island nation. While precise details surrounding the history of the operation are scarce, it is believed that, sometime around 2012, the IRGC began to quietly support violent Shi'a militant and terrorist cells in Bahrain (including Sarayah al-Ashtar, Sarayah al-Kasr, and Saraya Mokhta), and spur them to violence towards the Wahhabi Sunni monarchy.<sup>127</sup> According to Bahraini authorities and U.S. experts, Iranian, Hezbollah, and Iraqi Special Group forces<sup>128</sup> frequently smuggle Shi'a criminals and members of certain Bahraini Shi'a militant cells to Iraqi and Iranian camps by boat, where they are given training in explosives, small arms, logistics, and spy-craft.<sup>129</sup> Once their training is complete, these militants are either moved to Iran to operate as coordinators for Bahraini militant cells, or smuggled back into Bahrain by boat, along with explosives, small arms, and materials for further weapons production.<sup>130</sup>

In December, 2013, Bahraini officials seized a supply boat containing thirty-one Claymore antipersonnel fragmentation mines, 12 EFP explosive warheads, and dozens of detonators.<sup>131</sup> In July 2015, Bahrain's Coast Guard captured another boat, attempting to smuggle

some 43.8 tons of C4 explosives, forty-nine detonators, and several AK-47s into Bahrain.<sup>132</sup> Although it is impossible to tell how much weaponry reached Bahrain undetected, a Bahraini counter-terrorism unit did discover several weapons caches and bomb making facilities in 2015 containing hundreds of AK-47s, multiple IRAM mortars, dozens of pipe bombs and hand grenades, several tons of C4, TNT, and RDX, barrels of precursor materials for ammonium nitrate IEDs, detonators, and industrial systems for constructing EFPs featuring both radio control arming switches and passive infrared sensors.<sup>133</sup> Bahraini and U.S. authorities have, with high confidence, assessed that the seized materials were smuggled into Bahrain from boats originating in Iraqi and Iranian seas.<sup>134</sup> In the case of one captured smuggling ship, Bahraini authorities seized a GPS tracker, which showed that the boat had made repeated trips to Iranian waters.<sup>135</sup> In this light, although no materials were seized during 2016, 2017, or early 2018, it is logical to assume that ordinance slipped through Bahraini hands.

Iran's successful smuggling operation in Bahrain demonstrates a significant degradation of Bahrain's border security. In short, the influx of Iranian smuggling operations has stretched Bahraini Coast Guard's capabilities too thin to adequately secure Bahrain's entire coastal border. Iranian smuggling, however, has also resulted in dozens of IED attacks on civilians and government officials since 2012.<sup>136</sup> As a result of these attacks, the Bahraini government has imposed a curfew on all maritime activities after 6pm<sup>137</sup> and made significant portions of the island (primarily the geographic areas inhabited by the Shi'a majority) strictly off-limits to law-enforcement, military personnel, and government officials and their families.<sup>138</sup> This restriction of movement, along

with the weakening of Bahrain's border security within Bahrain, has significantly eroded the Territorial Security of Bahrain, and thus considerably undermined the Security of Bahrain in general.

Yemen, 2015-present (Cessation of Large-Scale Violence)

Over the past three years, Iran has engaged in activities designed to intentionally prolong the violence raging in Yemen. Since 2015, Iran has provided millions of dollars of military aid to the Houthis, a group of Zaidi Shi'ites from the mountains of Yemen, in their fight against the Yemeni government and the nations of the Gulf Cooperation Council (namely Saudi Arabia). Although repeated attempts have been made to reach a peace agreement, Iranian aid to the Houthis has consistently fueled violence and derailed attempts to implement cease-fire agreements. Examples of lethal aid include sniper rifles, RPGs, anti-tank guided missiles (ATGMs), and various small arms.<sup>139</sup>

Iran has also provided the Houthis with training, military consultation, and sophisticated weaponry. In December, 2017, Houthi forces launched a short-range, Iranian made Qiam ballistic missile at al-Yamama Palace in Saudi Arabia's capital of Riyadh.<sup>140</sup> On March 26, 2018, the Houthis launched seven more missiles at Riyadh;<sup>141</sup> another missile was launched at Najran just five days later.<sup>142</sup> Although Saudi Patriot ABM batteries shot down almost all of these missiles before striking their targets, Saudi Arabia has no long term plan to solve the problem. American officials have assessed that these missiles were made in Iran, and given to the Houthis in order to attack Saudi Arabia, Iran's principle adversary in the Arabian Peninsula.<sup>143</sup> Authorities have also assessed that Iranian operatives were behind the Houthi's use of an explosive "drone boat" to attack

a Saudi warship on January 30, 2017<sup>144</sup>, and the use of an explosive-laden Qasef-1 “suicide” drone to attack a Saudi Patriot batteries in February, 2017.<sup>145</sup> Finally, in March 2018, it was discovered that Iran had provided Houthis with the materials needed to construct IEDs featuring radio control arming switches and EFPs with passive infrared sensors, camouflaged as small, roadside rocks.<sup>146</sup>

It is believed that, in some cases, the Houthis have obeyed direct orders from IRGC leaders in the field. At the very least, the Houthis are directly influenced by IRGC commanders.<sup>147</sup> Iranian involvement in Yemen has, therefore, both actively and passively encouraged the continuation of violence in Yemen. Such violence has prevented the separation of the warring parties and precluded the possibility of cease-fires and peace negotiations. The result has been even greater erosion of the Security of Yemen, and overall instability in the state.

### **Iran’s Stability Operations: The Other Side of the Coin**

Iran is, however, also heavily invested in stability operations. In many cases, Iran’s destabilization operations have been followed up with operations to stabilize the nation which they had attempted to destabilize. This should come as no surprise: the ultimate intent of destabilization operations is seldom to merely create instability (especially when is in the target nation is in your neighborhood), but rather to use instability to advance progress towards strategic goals, most of which eventually require stability in the target nation. Iranian activities in Iraq are a perfect example of this fact: although they initially utilized an array of Iraqi armed groups and proxy forces to erode

physical security, their end goal was to drive the United States out of Iraq, bolster Iran's reputation within Iraq, and position their proxy forces as legitimate politico-military movements within Iraq. These goals required that Iran expend resources and energy to stabilize conditions across Iraq once the United States had been driven from Iraq and Iranian proxy forces had gained legitimacy. Such an attempt can be seen from Iranian the participation of these proxy forces in the fight against ISIS in Iraq (though Iran also used this opportunity to train Shi'a militants for destabilization operations in other nations.)

### **Countering Iranian Stability Targeting, 2018-future**

In order to ensure stability in the nations mentioned above, governments must invest in proactive stability and counter-destabilization activities. Countering Iranian stability targeting activities in the Security sector is a complex task, which requires a realistic appraisal of each state's critical vulnerabilities, a comprehensive analysis of Iranian activities, and creative consideration of countering activities. However, it should also be noted that any analysis of Iranian destabilization operations should include a critical factors analysis, which attempts to examine the critical capabilities, requirements, and vulnerabilities for Iran's destabilization mechanism as a whole. For example, each of the operations discussed above illustrates Iran's foundational destabilization mechanism: unconventional warfare supporting local non-state armed groups. The critical capabilities that must be met for that mechanism include (but are not limited to): proper funding for groups, safe and secure supply lines, sufficient command and control structures to direct group actions, and reliable means of



communication. “Proper funding for groups” features at least two critical requirements, including “receive funding for groups from leadership” and “safely deliver funding to groups”. Finally, “safely deliver funding to groups” relies on a critical vulnerability of “international interdiction of Iranian finances”. The example above is merely for illustrative purposes – but it does show how a critical factors analysis of Iranian destabilization operations immediately reveals a (fairly obvious) critical vulnerability in Iran’s destabilization mechanism, which can be exploited U.S. and international officials to analyze Iran’s destabilization mechanisms. From a U.S. whole-of-government point of view, countering Iranian destabilization operations requires a direct attack on the Iranian capability to support their destabilization activities.

**Appendix E: Stability Targeting Case Study**  
**The People's Republic of China:**  
**Economic Targeting**

**Hiram Reynolds**  
**The Fletcher School of Law and Diplomacy**

This case study examines the Chinese government's approaches to and interests in stability targeting. Chinese stability targeting activities focus on a range of different regions, institutions, and international norms. In contrast to some US adversaries and localized conflicts, Chinese stability targeting often occurs on a global level and with a range of strategic objectives in mind. As explained earlier in this paper, stability targeting is broader than destabilization alone, and in some cases Chinese stability targeting operations are conducted in the interest of long-term stability, a stability environment created on the Chinese government's terms and in the Chinese Party's interests. As illustrated elsewhere in this paper, this can be true of the stability targeting activities of Iran, FARC, and other groups as well, whether state actors or non-state armed groups and whether US adversaries or partners.<sup>148</sup> The overarching goal of Chinese stability targeting today is to increase Chinese influence and foreign policy options long-term, and should be viewed in the context of larger Chinese government efforts at transitioning from a regional power to a global leader.

This study begins with an overview of how stabilization fits into Chinese strategic posture and national security objectives, and also how stabilization has been framed to date in high-level PRC documents akin to the US National Security Strategy. Outside of Chinese government strategic literature, there

is evidence of Chinese interests in providing other countries with an alternative to many Western norms, laws, institutions, financing, and the underlying rules-based system that has led the international community since the end of WWII.<sup>149</sup> This is central to the examination of Chinese stability targeting and is perhaps the Chinese state's foremost objective of its stability targeting, in the context of the rise of China as an economic and political superpower. As it transitions to a global power Chinese norms and values are presented to the world, sometimes buttressing and sometimes subverting the Western-led international system as is calculated to be in Beijing's best interest, and stability targeting comprises an important piece of this strategic transition.

Beneath this global, international system-level stability targeting, Chinese levers of state power are also targeting specific areas of strategic importance such as the South China Sea ("SCS"). In addition to the SCS, specific focus is given to Western China, Chinese foreign policy towards some of its closer neighbors, and the New Silk Road or One Belt One Road (OBOR) initiative. OBOR is instrumental in expanding Chinese influence beyond East Asia and its immediate periphery, aiding China's rise along strategic, political, economic, military, and cultural channels. Some aspects of the implementation and realization of OBOR comprise stability targeting, as demonstrated below. Certain parts of China's ongoing Develop the West campaign also comprise stability targeting, which is of note because, in contrast to Iran, FARC, and other adversaries, some of Beijing's stability targeting is directed domestically. The three case studies included in this paper illustrate how stability targeting can be employed by US adversaries from a localized conflict to the world stage, both at home

and abroad, and why both proactive stabilization and counter-destabilization efforts must address the full range of adversary stability targeting capabilities.

This case concentrates on the Stable Economy Stability Sector in particular, and on real and potential stability targeting thereof. Economic destabilization and re-stabilization is of particular relevance to Party interests and activities, especially the intersections of the Economic, Security, and Rule of Law Stability Sectors. Unlike many adversaries, China has sufficient economic resources to conduct stability targeting on a global level with unique ways and means. Exploring the Economic lens through which stability targeting may be advanced and detailing how US stabilization and counter-destabilization operations may be conducted in this evolving context enables the Interagency to mitigate conflict and better meet national security objectives.

## **Increasing Influence Abroad**

President Xi, members of the Politburo Standing Committee, and other top Chinese leaders are actively transitioning China from a regional power to a global leader. The “Rise of China” has been a topic of much discussion for many years now, and China’s development as a political as well as an economic global superpower has intensified under President Xi’s concerted leadership. There is ongoing debate about Chinese grand strategy, the extent to which it has been shifted or reoriented under Xi’s leadership as contrasted with previous leaders, and the intentions and implications for other states. Implications resound for non-state actors as well, from multinational corporations (MNCs) to multilateral institutions, international organizations, INGOs, and

flows of goods, services, and people. Some claim that while other countries are playing a four-year game of Chess, China is playing a two-century game of Go, while others contest that Chinese strategy really is so farsighted. What is clear is that the implications of the “Rise of China” will be felt globally and long-term, and that they are a priority of study for US strategic political, military, and economic leaders.

As China’s role in world affairs grows and Beijing plays a greater part in international institutions and governance processes, the main objective of its stability targeting activities is to increase its influence abroad. In many different areas Beijing is choosing whether to take on more responsibility as its power grows, from peacekeeping, counter-piracy, and counter-narcotics efforts to infrastructure development, climate change mitigation, and counter-terrorism. Beijing is expanding its sphere of influence and furthering its ability to dictate terms abroad, and stability targeting is one effective approach to do so.

## **Chinese Development in Africa**

Many countries are eager for the extraordinary sums of capital Beijing is offering as part of its overseas development activities. This is particularly appealing to many developing countries at a time when Washington’s political outreach and economic aid and investment are waning in many parts of the world. Independent of policymakers’ intentions, many foreign governments perceive an abdication of leadership and support from the US, making it all the more important that the US Interagency, in conjunction with its partners, work to assuage these concerns and maintain a strategic advantage. With a large checkbook and vast supply of cheap labor, however, many developing and developed countries are clamoring for greater favor

with and support from Beijing, seeing it as filling a global leadership void.

Another crucial reason many countries are so welcoming of Beijing's resources even when it comes at the expense of some of their own political power – and possibly at a cost to relations with Washington – is that Beijing has historically been more keen to turn a blind eye to poor governance or domestic unrest in recipient nations. China is more accepting of authoritarian regimes with poor human rights records and lower valuations of citizens' rights and civil liberties. In many countries the US has traditionally been perceived as a more interactive partner, providing ongoing aid, investment, and support in exchange for democratic elections and agreements on how the country will structure its economy, write its constitution, and employ its military and law enforcement. In contrast, in many African countries in particular, Beijing is seen as offering international assistance without strings attached.

That Beijing's aid comes without conditions is a myth. Long-term, Beijing's economic and political influence in these countries is growing and time will show in which states Beijing's aid has been mutually beneficial and in which states it has been of benefit to China at the shrewd expense of the recipient state. In either case, there exists a narrative in many countries that the US is an exploitative partner or a "fair-weather friend" that makes many demands and tightly controls how its dollars are spent whereas China is more interested in a positive-sum partnership that allows the host nation to distribute its yuan as it chooses. China can take advantage of this narrative to further its "going global" strategy in Africa in particular but also in the Middle East, Latin America, Europe and Australia and elsewhere, including in the US.<sup>150</sup>

For decades China's international development efforts were shrouded in relative secrecy, but this has changed in the 21<sup>st</sup> century as Chinese development in Africa has come under the spotlight. It has hit a new level of strength and reach under President Xi's leadership in particular. China has thousands of peacekeeping troops and special forces on the continent. (According to Arab and Israeli media, it also has deployed special forces units in Syria, primarily to combat ethnic Uighur terrorists fighting the Assad regime.<sup>151</sup>) In addition to infrastructure investment and commercial activities, especially in agriculture,<sup>152</sup> it is also becoming more actively engaged in security matters. China's first overseas military base is located in Djibouti, not far from the capital city or from Camp Lemonnier.

The Chinese line is that it is bringing many millions of Africans out of poverty just as it succeeded in doing with much of its own population, that it is helping Africans modernize and increase their wellbeing and standards of living, and that it embraces the 'no strings attached' development model simply because it does not believe in meddling in a foreign state's internal affairs. It is clear why this narrative has found a wide and supportive audience, and that in many cases the strategy appears to be working. US policymakers must be cognizant of China's development efforts in Africa, particularly the high degree of attention they have received at high-level government meetings like the China Development Forum over the last several years. US policymakers must also be particularly attuned to the US Interagency response and maintain a coordinated and long-term strategy in response, especially given security concerns from groups such as al-Shabaab, Boko Haram, and AQAP that threaten stability and that are involved in international criminal networks beyond Africa as well.

## One Belt One Road and Debt-Trap Diplomacy

China has acquired over a dozen ports in the Indian Ocean. It controls ports in other regions of the Indo-Pacific as well, in addition to areas of the Mediterranean and the Atlantic. Chinese control of the Piraeus Port in Greece has received especial attention. China is also gaining influence and political power through economic means in South America. According to the World Economic Forum, China is the most important trading partner for more than 100 countries, including Argentina, Brazil, Chile, Peru, and Uruguay.<sup>153</sup>

Control of these ports is crucial to China's ability to leverage economic power over the recipient state for China's gain. This leverage is a major mechanism of stability targeting through what has been termed "debt-trap diplomacy." There are growing concerns that Chinese financing of megaprojects, often tied to infrastructure development such as building ports and transit links conducive to trade, grants Beijing sufficient leverage that the host countries are indebted to the extent that Beijing can exercise influence in their political and security affairs. Though such financing is initially appealing, ostensibly innocent commercial and financial activity may disguise more invasive or abusive objectives. Just as stability requires a monopoly on the use of force, it also requires at least substantive control of the use of that country's economic resources.

This strategy is playing out around the world, from Latin America to Southeast Asia to Africa. Sri Lanka is an oft-cited example. Sri Lanka after its civil war was desperate for foreign economic assistance. China offered to help finance Sri Lanka's reconstruction without the strict political conditions and financial risk controls Western lenders demand, as described



above in much of Africa. Renminbi continued to flow into Sri Lanka, but the debt burden became untenable as Sri Lanka's economic recovery failed to materialize alongside booming infrastructure projects. Additionally, in contrast with the guidance and best practices of many Western development organizations, China tends to use Chinese laborers to build its projects overseas rather than finance the project and allow domestic jobs to be created to build the project, which is of clear benefit to China at the expense of the host nation. In lieu of repayment of its, as that option faded over time, Sri Lanka instead relinquished majority control of Hambantota port. This caused concern both in Sri Lanka and elsewhere that China's economic maneuvers pose a threat to the sovereignty of countries hungry for development, but vulnerable.<sup>154</sup>

As illustrated by the Sri Lanka case, this strategy is particularly effective in states already undergoing some sort of domestic crisis. Financing of megaprojects and a fast infusion of capital into a stressed economy is an especially great boon to national leaders struggling with domestic unrest resulting from high unemployment or other symptoms of ailing economic conditions. Venezuela is a prime example of Beijing targeting countries in such conditions to gain greater leverage and influence in the country and region. More than half – 53% – of all Beijing's investment in South America is directed towards Venezuela. Venezuela is a key oil-exporting economy and Beijing's FDI infusion comes as the country is experiencing widespread protests and civil unrest, food shortages, increasing crime and disease rates, and a worsening refugee crisis. These challenges threaten the stability of the Maduro administration, further incentivizing the government to accept Chinese investment deals even on terms that give Beijing great leverage and influence down the road.<sup>155</sup>

Concerns that other countries may follow a path similar to Sri Lanka's are growing. There has been particular concern amongst African nations. Not all Chinese acquisitions of overseas ports lead to the same results. China is pursuing investment deals across Europe as well. The Piraeus Port, for instance, has gained media attention and corporations are debating whether it will be financially viable for Beijing in the long-term to pursue deals of this sort. In Djibouti, in addition to building its first overseas military base, China also a new port, two new airports, and a railway linking Djibouti and Ethiopia. Djibouti is considered the first "pearl" in China's "String of Pearls," referring to Chinese ambitions to secure sea routes across the Indian Ocean to the Middle East and North Africa.<sup>156</sup> This enables China to use its "back door" through Pakistan or the Central Asian Republics, as illustrated through OBOR below, rather than remaining largely reliant on shipping exports through the Malacca Strait.

### **Chinese Ports in the Indian Ocean**

We should also bear in mind when thinking about OBOR that in addition to being a \$1 trillion, multi-year project involving many different countries on three continents, the Initiative links the majority of the world's population by trade and transit routes, by land and by sea. Consider the following image—more people live within the highlighted circle than live outside it. No other country is conducting stability targeting of the Economic Stability Sector on such a massive, intercontinental scale.

Many question the financial viability of certain elements or specific deals of OBOR, when it must be seen in its entirety as a long-term strategy that combines multiple tools of power, not economic and financial

goals alone. Whether or not short-term profits are likely from the acquisition of a particular port, construction of a particular stretch of highway, or investment in a particular rail link, for instance, political and security concerns may effectively subsidize financial targets. Similar concerns were raised during the rollout of the US Marshall Plan, but this was of great benefit to the US in the long-term, especially in indirect ways – cultural, strategic, and political.<sup>157</sup> In other words, the Marshall Plan succeeded and helped further establish the US role as a global leader because it was not merely about economic aid, and OBOR, which dwarfs the Marshall Plan in both monetary and geographic terms, should be considered in a similarly comprehensive manner.

### **South China Sea**

The South China Sea is of immense strategic importance to Beijing. It falls within the First Island Chain and the Nine-Dash Line. It is an importance geostrategic buffer zone for conventional Chinese security, and in addition to the naval assets and conventional military considerations, the Sea is home to vast fishing, oil, natural gas, and other economic resources.

Some of China's stability targeting operations in the South China Sea are more in line with typical hybrid and unconventional warfare activities and the sort of covert operations we think of as more traditional military destabilization mechanisms. Chinese naval special operations have given rise to the phrase "Little Blue Men" in reference to Russian hybrid activities in Ukraine. China has been using Coast Guard rather than Naval forces to reinforce its claims that any activities conducted in the SCS are conducted in its own territorial waters.

The SCS is of even greater significance to China as a matter of precedent and political legitimacy. Taiwan forms a part of the First Island Chain. China has claimed the sea as part of its territorial waters, despite judicial rulings by the International Tribunal for the Law of the Sea on disputed maritime features in the SCS that fell in the Philippines' favor, and conclusions that many of Beijing's maritime activities in the SCS fall within the Philippine's EEZ and are therefore illegal under several different articles of UNCLOS.

Despite its ratification of UNCLOS, however, Beijing may be playing a more nuanced hand by simultaneously remaining party to the international convention, achieving tactical, strategic, and, in effect, sovereign control of the SCS by way of a *fait accompli*, and undermining a major body of international law associated with arguably Western-dominated institutions like the UN the ICJ. It is up for debate whether this last clause is either accurate or ultimately in Beijing's best interest as a growing superpower, and it is important to remember that even under Xi's strong leadership, the CCP is not a monolithic entity of uniform geopolitical opinions. In any case, Chinese stability targeting in the SCS encompasses covert military operations and also goes beyond them, addressing Beijing's greater political interests in consolidating its control of the Sea and its periphery.

Some argue that the SCS issue will be resolved when China considers itself a global rather than a regional power.<sup>158</sup> At this point it will be more important to the Chinese national interest to support norms such as freedom of navigation, innocent passage, transit passage, even enhanced standards of environmental sustainability in foreign direct investments. In recent years China has become a net energy-exporting country, Chinese outgoing investment has grown to exceed

incoming investment even with new reforms easing financial investment into the mainland, and cheap manufacturing is shifting away from China towards other South and Southeast Asian nations. When the Soviet Union transitioned from a “reactive coastal fleet designed to counter US nuclear-armed aircraft carriers to a proactive, expansionist, blue-water navy,”<sup>159</sup> the Soviet Union interest in law of the sea shifted from “one that sought to limit maritime freedoms to one that joined hands with naval powers, including its Cold War foe, the United States, to push for protection of such freedoms. A similar shift would help boost China’s international reputation, as well as protect and advance its interests across the globe.”<sup>160</sup> All the more reason not to succumb to notions of a Thucydides Trap or to lend credence to any self-fulfilling prophecies thereof. The US Interagency, in conjunction with public-private partnerships, must recognize Chinese strategies and mechanisms of both stabilization and of stability targeting, and identify areas of aligned stabilization interests as well as conflicting counter-destabilization aims.

## **Conclusion**

China is engaged in its own stabilization, stability targeting, and counter-destabilization operations. Some of these operations are in line with US national security interests and some are in direct conflict with US interests, while most fall on uncertain middle ground, under the nuanced and capricious influences of different US and PRC leaders and interests, both public and private. A basic understanding of the Chinese government’s and military’s conceptualizations of stability is therefore crucial to an effective and forward-thinking US Interagency stabilization strategy. This is

particularly true given the global and ongoing impacts of President Xi Jinping's leadership, of OBOR, and of China's developing role as an interregional leader and world power.

China provides one valuable case study of the mechanisms through which stability targeting interests are advanced. The Chinese state has the economic and the political resources to destabilize US and other state interests in ways unavailable to most US adversaries. In addition to being the world's second largest economy (still growing at a considerably faster rate than the US), China's political system in conjunction with its massive financial and economic power provides ways, means, and long-term options that most countries cannot afford. This is particularly true under Xi's rapid consolidation of power, assertive leadership, and broad support of China's political elite. He is expected to serve as China's top leader for at least the next ten years. As both political adversary and uniquely essential trade partner to the US, an illustration of the challenges and opportunities inherent to stabilization vis-à-vis China is vital to meeting the objectives of the NSS and NSC National Security Challenge #8. China provides a singular view of how the US Interagency can build, support, and protect critical requirements of a Stable Economy, and of how the Stable Economy Stability Sector and other Stability Sectors, most notably Security, are interrelated.

China is a US partner as well as a US adversary. The relationship is complex at best, and even more so when considered in historic and in multilateral context. It is important for USG operators, agents, and public servants to find areas of cooperation with China, especially as USG Interagency strategists look to the future. Each adversary is unique; China is not akin to other US adversaries in its means nor its

intent in stability targeting of neighboring regions or, necessarily, the world order at large. In some cases US and Chinese stability and counter-destabilization operations and objectives are at odds and in some cases they are aligned. The foreign policy and national security communities of both countries should identify areas of cooperation and of competition to better ensure that bilateral and multilateral relations remain below the threshold of conflict and that the rise of China does not make a self-fulfilling prophecy out of Thucydides Trap debates.

This sets China apart in some ways from the other adversaries considered in this paper, Iran and FARC. China, like each element of the 4+1 threat framework, is unique. It is not a monolithic actor. The Chinese Party and government,<sup>161</sup> the political, military, and business establishments, the citizenry and the 52 ethnicities that officially comprise it, are not monolithic entities. With this in mind, China is also unique in its long-term thinking and its ability to exercise long-term thinking; the implementation of Party policy directives are not held back by 4-year term limits, particularly not under President Xi's leadership. Historically and today, China is sometimes capable of exercising a long-term and unified DIME strategy in ways that the US conception of "whole-of-government" currently struggles to attain.

## **Appendix F: Transitional Public Security**

During and immediately following armed conflict, the Army, as part of the Joint Force, must be prepared to conduct transitional public security tasks and must be responsible for public order in place of the host nation. The Army must execute Transitional Public Security, as a subset of Establish Civil Security, when the rule of law has broken down, is nonexistent, or when directed by the JTFHQ.

The purpose of Establish Civil Security is to:

- consolidate friendly gains during and after armed conflict<sup>162</sup>
- prevent adversaries from re-igniting conflict or re-imposing their will
- set conditions for transition to other competent authority

Transitional Public Security is a military-led effort to restore civil security, protect the civilian population, and maintain public order until the Joint Force is able to transfer that responsibility to a competent authority.



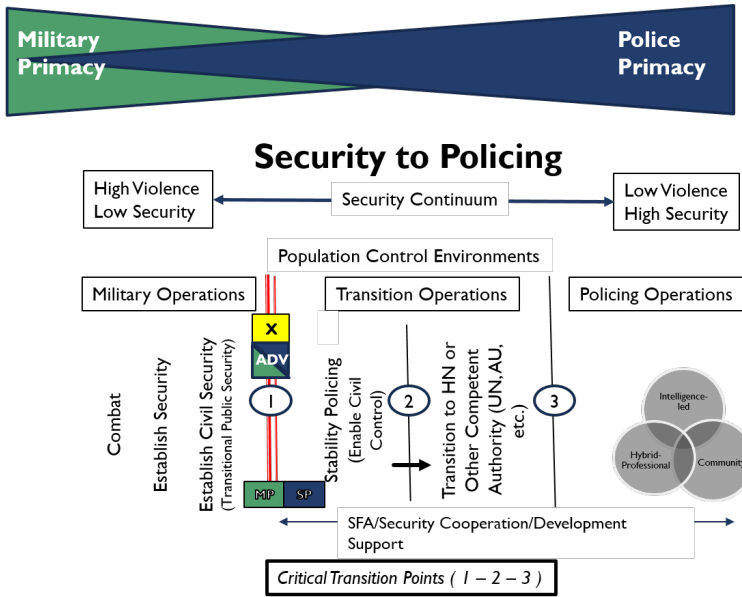

**Figure 15. Transitional Public Security Concept**

Key tasks during TPS include:

- Establish civil security<sup>163</sup> and public order
- Conduct interim detention
- Conduct interim adjudication

TPS tasks, by their nature, are usually or best performed by police; however, because of the conditions and/or required capacity to conduct them, they will likely be performed by combat forces.

As civil security improves, efforts to establish civil control will increase. TPS enables this process. TPS does not establish civil control\* <sup>164</sup> nor lead foreign humanitarian assistance, economic stabilization, rule of law or governance and participation efforts. These stability activities are civ/mil efforts and are outside the scope of TPS.

\* Civil control fosters the rule of law. It is based on a society ensuring individuals and groups adhere to the rule of law and that society embraces the rule of law to provide equal access to a legal system consistent with international human rights principles. It is a long-term process guided by civilian entities



## Appendix G

### Notes on Terminology

While there are issues with some of the definitions for stability (specifically for the stability sectors and joint stability functions), this white paper does not seek to modify or expand any of the existing definitions. The ideas expressed in this paper are based on the definitions found in joint publications and concepts.

To better articulate the overall rubric of stabilization, the following definitions are used throughout this paper to maintain consistency:

- **Stabilization** – Stabilization is the umbrella term for this paper. It is a political endeavor involving an integrated civilian-military process to create conditions where locally legitimate authorities and systems can peaceably manage conflict and prevent a resurgence of violence. Requires aligning U.S. Government efforts – diplomatic engagement, foreign assistance, and defense – toward supporting locally legitimate authorities and systems to peaceably manage conflict and prevent violence. (From the *Stabilization Assistance Review*.) Stabilization consists of proactive stability and counter-destabilization.
- **Proactive Stability** – A component of stabilization. USG actions taken to strengthen, harder, or increase the resiliency of an ally's or partner's stability sectors in order to prevent adversary destabilization actions from being effective. Proactive stabilization consists of supporting critical capabilities, improving or reinforcing

critical requirements, and mitigating critical vulnerabilities.

- **Counter-Destabilization** – A component of stabilization. USG efforts to defeat an adversary’s destabilization activities. Destabilization activities will be part of a larger adversary campaign to achieve positional advantage. Counter-Destabilization targets destabilization mechanisms, and interdicts the resources (means) that an adversary has at its disposal.
- **Stability Targeting** – The actions taken by an adversary to undermine or weaken the stability sectors within a region, state, or area. An adversary can target a single sector, a combination of sectors, or stability writ large. States, non-state actors, and illegal armed groups all use or capitalize on instability to achieve objectives at all levels (tactical through strategic) by undermining U.S. influence, coercing or coopting power structures, or by manufacturing justification for additional action.
- **Destabilization Mechanisms** – The primary methods through which an adversary undermines stability in order to achieve strategic objectives. Destabilization mechanisms are an amalgamation of destabilization approaches. Through the targeted application of destabilization mechanisms, an adversary creates pathways to requirements and capabilities that ultimately shape stability sectors in specific ways.
- **Destabilization Approach** – The conditions, tools, and/or actions an adversary uses to target an opponent’s vulnerabilities in order to

undermine or weaken a stability sector. Destabilization approaches focus the application of resources. The effectiveness of a destabilization approach is a combination of the resources applied to it and the weakness of the vulnerability it is applied against.

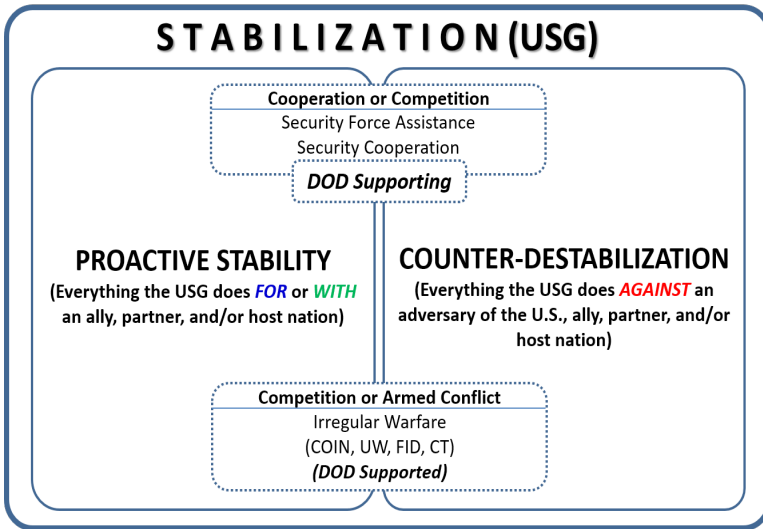

Neither JP 1-02 (*DOD Dictionary of Military and Associated Terms*, March 2018) or ADRP 1-02 (*Terms and Military Symbols*, 16 November 2016) define the terms *domain*, *environment*, or *space*. In many cases these three terms are used interchangeably to describe different parts and/or components of the battle space. PKSOI employs the following definitions throughout this paper for the sake of consistency:

- **Domain** - The physical or virtual medium through which one actor competes with (competition stage) or attacks through (armed conflict stage) in order to achieve an effect.

Domains remain the same regardless of who is operating within the domain – they are force agnostic. The Joint Force recognizes five domains: *Land, Air, Maritime, Space, and Cyberspace*. TRADOC's MDB Concept defines a domain as “an area of activity within the operating environment (land, air, maritime, space, and cyberspace) in which operations are organized and conducted.”

- **Environment** – The area where competition takes place, and where actors are not able to control everything in the area. Environments are force dependent – they change based on who the actors are. Example environments include the *human environment, information environment, decision environment, and influence/engagement environment*.
- **Space** – Describes where an actor attempts to gain advantage over an antagonist. Examples of different spaces include the *physical space, virtual space, cognitive space, and temporal space*.

## **Appendix H:**

### **Additional Questions for Further Exploration**

- Does the military need to reconsider our role across all stability functions differently based on the authorities and approvals required to have a direct impact on the stability functions?
  - Should the military seek out new authorities in the competitive space, or should we reframe how we conduct current operations to support future interorganizational activities?
  - Does this jeopardize military effectiveness and put achievement of military objectives at risk?
  - Does greater military action during the competition stage risk militarizing foreign diplomacy?
  
- How does the joint force define key stability functions such as *governance*?
  - Are our joint definitions helpful, or do they limit our understanding and our potential maneuver space? Do they enable us to maximize our effects?
  - Are the definitions we developed for the stability functions on the fly during the wars in Iraq and Afghanistan sufficient as we move forward into MDB?
  - Can we use our definitions to effectively communicate with interorganizational partners?
  
- Are there alternatives to U.S. provided stability, and what would the role of the U.S. military and USG be in these alternatives?



- How does the Army prevent adversaries from consolidating gains?
- Is there a military-style converse to the “Guidance Principles” – a “New Generation Adversary Guiding Principles” – that articulates destabilizing activities, and lays out how we defend key institutions and areas?
- How do we convince others that we need a “counter-capability” for stability?
- Does the “generalist” framework of five stability sectors work or should we develop more specific models for different areas and different threats? Does the current framework enable a planner to move from a general model to specific application?
- Are the five stability sectors co-equals or is one more important than all of the others (foundational)? Is there a “stability hierarchy,” and how might it possibly change over time, across space, and under different conditions?
- What does “Military Support to Governance” really look like? Is it different under MDB than it was in the past? Do historic models such as World War II methods of military governance truly inform future challenges?
- Do we need to *deliberately* adopt a more pragmatic perspective (as opposed to an altruistic one) given resourcing challenges with respect to stability operations?
- Do we understand power dynamics, how influence is wielded at the local level, how that influences other subnational and national levels of government, and how we as the Joint Force impact that?

## ENDNOTES

1. US Army Training and Doctrine Command (TRADOC), *Multi-Domain Battle: Evolution of Combined Arms for the 21<sup>st</sup> Century 2025-2040, Version 1.0* (Fort Eustis, VA, December 2017). TRADOC released a draft version in October 2017, and followed up with a final version in December. The December version is approved for public release.

2. *Ibid.*, 1.

3. Headquarters, Department of the Army (HQDA), *FM 3-0 Operations* (Washington, DC: The Pentagon, October 6 2017), p 1-17.

4. *Ibid.*, 1-6.

5. Joint Staff, *Joint Campaign for Integrated Campaigning* (Washington, DC: The Pentagon, March 16, 2018), vi.

6. Joint Staff, *Joint Operating Environment 2035* (Washington, DC: The Pentagon), ii & 4.

7. Maneuver Center of Excellence, *Ensuring Readiness and Building the Future Maneuver Force* Briefing, Reviewed September 23, 2017.

8. TRADOC, White Paper "Multi-Domain Battle: Combined Arms for the 21<sup>st</sup> Century," February 24, 2017, 2.

9. Joseph L. Votel, Charles T. Cleveland, Charles T. Connett, and Will Irwin, "Unconventional Warfare in the Gray Zone," *Joint Forces Quarterly* #80, 1<sup>st</sup> Quarter 2016, 101-109.

10. Joint Staff, Joint Doctrine Note 1-xx, *The Competition Continuum* (Washington, DC: The Pentagon, November 28, 2017), 6. This JDN is currently a draft document and is cited here for clarity. This JDN will likely be superseded by the approval of the JCIC; however, this diagram does not appear in the approved JCIC.

11. George F. Kennan, "Organizing Political Warfare," April 30, 1948, 1. <https://digitalarchive.wilsoncenter.org/document/114320> (accessed August 28, 2017).

12. Nathan P. Freier, et al, *Outplayed: Regaining Strategic Initiative in the Gray Zone* (Carlisle, PA: US Army War College Strategic Studies Institute, June 2016), 5. <http://ssi.armywarcollege.edu/pubs/display.cfm?pubID=1325> (accessed July 21, 2017).

13. Joint Staff, *Joint Concept for Integrated Campaigning*, 7.

14. TRADOC White Paper, "Multi-Domain Battle," 4.

15. Ibid.

16. Ibid.

17. HQDA, *ADP 3-07 Stability* (Washington, DC: The Pentagon, August 31, 2012), 8.

18. TRADOC, *Multi-Domain Battle*, 12.

19. Joint Staff, *Joint Concept for Integrated Campaigning*, 3.

20. TRADOC, *Multi-Domain Battle*, 25.

21. Ibid., 22.

22. Ibid., 37.

23. Joint Staff, *Joint Concept for Integrated Campaigning*, 2.

24. TRADOC, *Multi-Domain Battle*, 20-21.

25. Valery Gerasimov, "The Value of Science Is in the Foresight: New Challenges Demand Rethinking the Forms and Methods of Carrying out Combat Operations," *Military Review* (January-February 2016). Originally published in *Voyenno-Prmyslenny Kurier* (*Military-Industrial Kurier*), February 27, 2013 and translated by Robert Coalson, editor, Central News, Radio-Free Europe/Radio Liberty. See the diagram titled "The Role of Nonmilitary Methods in the Resolution of Interstate Conflicts"

on page 28. While this article deals with Russian thoughts on the changing character of war, other adversaries actively practice similar constructs.

26. Joint Staff, *Joint Concept for Integrated Campaigning*, 5.

27. Joint Staff, *Joint Concept for Integrated Campaigning Executive Overview Brief*, August 2017, Slide 21. Reviewed September 15, 2017.

28. For more on the interaction of Defense, Diplomacy, and Development (3Ds) in USAFRICOM, see the following article: Ryan McCannell, "At The Nexus of Diplomacy, Development, and Defense - AFRICOM at 10 Years (Part 3)," US Army War College War Room, September 29, 2017. <https://warroom.armywarcollege.edu/articles/at-the-nexus-of-diplomacy-development-and-defense-africom-at-10-years-part-3/> (accessed January 4, 2018).

29. Gerasimov, "The Value of Science," 24.

30. Ibid.

31. TRADOC, *Multi-Domain Battle*, 12.

32. Gerasimov, "The Value of Science," 27.

33. TRADOC, *Multi-Domain Battle*, 25.

34. Joint Staff, *Joint Concept for Integrated Campaigning*, 4.

35. Ibid., 6.

36. Ibid., 4-5.

37. Ibid., 12-14.

38. Ibid., 15-17.

39. Joint Staff, *JP 5-0 Joint Planning* (Washington DC: The Pentagon, June 16, 2017), pp IV-31 – IV-33. See for a complete discussion and definitions of defeat and stability mechanisms.

40. Joint Staff, *Joint Concept for Integrated Campaigning*, 16-18.

41. *Ibid.*, 16.

42. *Ibid.*, 18.

43. *Ibid.*, 16-17.

44. Joint Staff, *Joint Concept for Integrated Campaigning*, 18.

45. Stabilization Assistance Review (SAR), “A Framework for Maximizing the Effectiveness of U.S. Government Efforts to Stabilize Conflict-Affected Areas,” 2018, ii.

46. *Ibid.*, 6.

47. Donald J. Trump, National Security Strategy of the United States of America (Washington, DC: The White House, December 2017), 3.

48. John M. McHugh and Raymond T. Odierno, *A Statement of the Posture of the United States Army 2015* (Washington, DC: The Pentagon, March 2015), 3, [https://www.army.mil/e2/rv5\\_downloads/aps/aps\\_2015.pdf](https://www.army.mil/e2/rv5_downloads/aps/aps_2015.pdf) (accessed January 26, 2018).

49. James N. Mattis, *Summary of the 2018 National Defense Strategy of the United States of America: Sharpening the American Military’s Competitive Edge* (Washington, DC: The Pentagon, January 19, 2018), 1, <https://www.defense.gov/Portals/1/Documents/pubs/2018-National-Defense-Strategy-Summary.pdf> (accessed January 19, 2018).

50. Mattis, *2018 National Defense Strategy*, 2.

51. Freier, et al, *Outplayed*, 4-5.

52. Mattis, *2018 National Defense Strategy*, 2.
53. Joint Staff, *Joint Concept for Integrated Campaigning*, 3.
54. Joint Staff, *JP 5-0 Joint Planning*, IV-23.
55. Joe Strange, "Centers of Gravity & Critical Vulnerabilities: Building on the Clausewitzian Foundation So that We Can All Speak the Same Language," *Perspectives on Warfighting* (Quantico, VA: Marine Corps War College, 1996), 3.
56. Ibid.
57. Ibid.
58. Gerasimov, "The Value of Science," 28. According to Gerasimov, the 6<sup>th</sup> stage of Conflict Development is "Restoration of Peace (*Post-conflict Regulation*)."
59. Gerasimov, "The Value of Science," 28.
60. SAR, "A Framework," 4.
61. "FARC- Rebels with a Cause?" *Council on Hemispheric Affairs*, July 6, 2010, <http://www.coha.org/farc---rebels-with-a-cause/>
62. "Foreign Terrorist Organizations," accessed March 30, 2017, <http://www.state.gov/j/ct/rls/other/des/123085.htm>.
63. David Spencer, "Getting to Peace in Colombia?" (Presentation, William J. Perry Center for Hemispheric Defense Studies, Washington, D.C., March 1, 2017).
64. Mike Schofield, "The Crime-Terror Nexus and the Threat to U.S. Homeland Security," Master's Thesis. Naval Postgraduate School, Monterey, California, 2015, 41.
65. Angela Rabasa and Peter Chalk, *Colombian Labyrinth: The Synergy of Drugs and Insurgency and its Implication for Regional Stability* (Santa Monica, CA: RAND, 2001) 23.

66. Schofield, "The Crime-Terror Nexus," 42.
67. David Spencer, "FARC's Transformation: The Combination of all Forms of Struggle," in *The Great Perhaps? Colombia: Conflict and Convergence*, 123-145. London: Hurst & Company, 2016, 126.
68. Spencer, "FARC's Transformation," 125.
69. Ibid., 126.
70. Ibid., 127.
71. Rabasa, "Colombian Labyrinth," 39-40.
72. David Spencer, "FARC's Transformation: The Combination of All Forms of Struggle," in *A Great Perhaps? Colombia: Conflict and Convergence*, (London: Hurst & Company, 2016) 141.
73. Spencer, "Getting to Peace in Colombia."
74. Spencer, "FARC's Transformation," 123.
75. United States Institute of Peace and United States Army War College, *Guiding Principles for Stabilization and Reconstruction* (2007), 10-162.
76. Ibid., 8-98.
77. Schofield, "The Crime-Terror Nexus and the Threat to U.S. Homeland Security," 41.
78. Spencer, "FARC's Transformation," 127.
79. Schofield, "The Crime-Terror Nexus," 44.
80. Ibid.
81. Spencer, "FARC's Transformation," 145.

82. Rabasa, "Colombian Labyrinth," 29.
83. John Otis, "The FARC and Colombia's Illegal Drug Trade" (Washington, DC: The Woodrow Wilson International Center for Scholars – Latin America Program, 2014) 13.
84. Ibid., 18.
85. Schofield, "The Crime-Terror Nexus," 45.
86. Spencer, FARC's Transformation,"137.
87. Ibid., 138.
88. United States Institute of Peace, *Guiding Principles*, 6-38.
89. Department of the Army, *Stability FM 3-07* (2014), 1-11.
90. Rabasa, "Colombian Labyrinth," 24.
91. Ibid., 17.
92. Rabasa, "Colombian Labyrinth," 17.
93. Ibid., 27.
94. Spencer, "FARC's Transformation," 127.
95. U.S. Library of Congress, Congressional Research Service, *Colombia: Background, U.S. Relations, and Congressional Interest*, by June S. Beittel, RL32250 (2012), 17.
96. Spencer, "FARC's Transformation," 134.
97. Ibid., 133.
98. Ibid., 139.
99. Danielle Renwick and Claire Felter, "Colombia's Civil Conflict," *Council on Foreign Relations*, January 11, 2017, accessed



April 18, 2017, <http://www.cfr.org/colombia/colombias-civil-conflict/p9272>.

100. Ibid.

101. Spencer, "FARC's Transformation," 128.

102. Ibid., 131.

103. <https://www.cia.gov/library/publications/the-world-factbook/geos/ir.html>

104. Joshua Gleis and Benedetta Berti, *Hezbollah and Hamas* (Baltimore: Johns Hopkins University Press, 2012), 38.

105. Levitt, 12.

106. Norton, 101

107. Hussain Abdul-Hussain "Hezbollah: A State Within a State", May 2009 (Accessed March 4, 2018) <https://www.hudson.org/research/9801-hezbollah-a-state-within-a-state>

108. <http://www.understandingwar.org/sites/default/files/reports/IraqReport06.pdf>

109. <http://www.understandingwar.org/sites/default/files/reports/IraqReport06.pdf>

110. <https://ctc.usma.edu/the-evolution-of-irans-special-groups-in-iraq/>

111. [https://www.army.mil/article/3890/iran\\_arming\\_training\\_directing\\_terror\\_groups\\_in\\_iraq\\_us\\_official\\_says](https://www.army.mil/article/3890/iran_arming_training_directing_terror_groups_in_iraq_us_official_says)

112. <http://www.understandingwar.org/sites/default/files/reports/IraqReport06.pdf>

113. <http://www.washingtonpost.com/wp-dyn/content/article/2007/08/19/AR2007081901394.html>

114. [www.nytimes.com/2007/07/02/world/africa/02iht-iraq.1.6442071.html](http://www.nytimes.com/2007/07/02/world/africa/02iht-iraq.1.6442071.html)
115. <https://www.iraqbodycount.org/database/>
116. <http://icasualties.org>
117. [http://news.bbc.co.uk/2/hi/middle\\_east/6286129.stm](http://news.bbc.co.uk/2/hi/middle_east/6286129.stm)
118. <http://www.understandingwar.org/sites/default/files/reports/IraqReport06.pdf>
119. <https://ctc.usma.edu/the-evolution-of-irans-special-groups-in-iraq/>
120. <http://iswresearch.blogspot.com/2017/10/return-of-signature-iranian-explosive.html>
121. <https://www.wsj.com/articles/SB10001424052748703994904575646911886138950>
122. <http://www.understandingwar.org/sites/default/files/reports/IraqReport06.pdf>
123. <http://www.bbc.com/news/world-middle-east-29603272>
124. <https://www.middleeastmonitor.com/20170924-shia-militia-accused-of-attacking-sunni-village-in-iraq/>
125. <https://www.hrw.org/news/2016/01/31/iraq-possible-war-crimes-shia-militia>
126. <http://www.washingtoninstitute.org/fikraforum/view/sunnis-and-shia-in-bahrain-new-survey-shows-both-conflict-and-consensus>
127. <http://docs.house.gov/meetings/FA/FA18/20171004/106468/HHRG-115-FA18-Transcript-20171004.pdf>

128. <http://www.mei.edu/content/io/bahrain-says-arrested-116-members-irgc-established-terror-cell>
129. <https://ctc.usma.edu/evolution-shia-insurgency-bahrain/>
130. <https://ctc.usma.edu/evolution-shia-insurgency-bahrain/>
131. <https://ctc.usma.edu/evolution-shia-insurgency-bahrain/>
132. <http://www.washingtoninstitute.org/policy-analysis/view/iranian-backed-terrorism-in-bahrain-finding-a-sustainable-solution>
133. <http://www.washingtoninstitute.org/policy-analysis/view/iranian-backed-terrorism-in-bahrain-finding-a-sustainable-solution>
134. [https://www.washingtonpost.com/world/national-security/us-increasingly-sees-irans-hand-in-the-arming-of-bahraini-militants/2017/04/01/be5e61fc-1329-11e7-833c-503e1f6394c9\\_story.html?utm\\_term=.4e32e1f8a4e0](https://www.washingtonpost.com/world/national-security/us-increasingly-sees-irans-hand-in-the-arming-of-bahraini-militants/2017/04/01/be5e61fc-1329-11e7-833c-503e1f6394c9_story.html?utm_term=.4e32e1f8a4e0)
135. <http://www.washingtoninstitute.org/policy-analysis/view/iranian-backed-terrorism-in-bahrain-finding-a-sustainable-solution>
136. <http://www.washingtoninstitute.org/policy-analysis/view/iranian-backed-terrorism-in-bahrain-finding-a-sustainable-solution>
137. <https://www.gov.uk/foreign-travel-advice/bahrain>
138. <http://smallwarsjournal.com/jrnl/art/iran's-involvement-in-bahrain>
139. <http://docs.house.gov/meetings/FA/FA18/20171004/106468/HHRG-115-FA18-Transcript-20171004.pdf> and <http://www.washingtoninstitute.org/policy-analysis/view/responding-to-irans-arms-smuggling-in-yemen>

140. <http://www.janes.com/article/75786/dossier-shows-iranian-missile-that-landed-in-saudi-arabia>
141. <https://www.nytimes.com/2018/03/25/world/middleeast/saudi-arabia-yemen-missile-houthi.html>
- 142 . <http://www.arabnews.com/node/1276641/saudi-arabia>
143. <https://usun.state.gov/remarks/8090>
144. [https://www.washingtonpost.com/news/checkpoint/wp/2017/03/22/houthi-forces-appear-to-be-using-iranian-made-drones-to-ram-saudi-air-defenses-in-yemen-report-says/?utm\\_term=.f216f82b5cc4](https://www.washingtonpost.com/news/checkpoint/wp/2017/03/22/houthi-forces-appear-to-be-using-iranian-made-drones-to-ram-saudi-air-defenses-in-yemen-report-says/?utm_term=.f216f82b5cc4)
145. Conflict Armament Research, *Iranian Technology Transfers to Yemen*, March 2017, [http://www.conflictarm.com/download-file/?report\\_id=2465&file\\_id=2467](http://www.conflictarm.com/download-file/?report_id=2465&file_id=2467)
146. [http://www.conflictarm.com/download-file/?report\\_id=2598&file\\_id=2600](http://www.conflictarm.com/download-file/?report_id=2598&file_id=2600)
147. <https://english.alarabiya.net/en/features/2018/01/01/Who-are-the-Iranian-Revolutionary-Guard-officers-leading-Houthis-in-Yemen-.html>
148. Douglas Farah and Carl Meacham, “Alternative Governance in the Northern Triangle and Implications for U.S. Foreign Policy: Finding Logic Within Chaos,” *Center for Strategic and International Studies*, September 2015.
149. Mattis, *2018 National Defense Strategy*, 2. 习近平, “决胜全面建成小康社会 夺取新时代中国特色社会主义伟大胜利,” “中国共产党第十九次全国代表大会”, October 18, 2017. Chinese text on 人民网: <http://politics.people.com.cn/n1/2017/1028/c1001-29613514.html>. English translation: Andrew Erickson, <http://www.andrewerickson.com/2017/10/full-text-of-xi-jinpings-19th-national-party-congress-work-report-related-documents/> “习近平：新时代的领路人”，中华人民共和国中央人民政府，November 17, 2017. [http://www.gov.cn/xinwen/2017-11/17/content\\_5240304.htm](http://www.gov.cn/xinwen/2017-11/17/content_5240304.htm) David Dollar, “China’s

Rise as a Regional and Global Power: The AIIB and the 'One Belt, One Road,'" *Brookings Institute*, July 15, 2015. <https://www.brookings.edu/research/chinas-rise-as-a-regional-and-global-power-the-aiib-and-the-one-belt-one-road/>

150. Deborah Brautigam, *The Dragon's Gift: The Real Story of China in Africa*, Oxford University Press: June 20, 2011.

151. Jacques Neriah, "Chinese Troops Arrive in Syria to Fight Uyghur Rebels," *Jerusalem Center for Public Affairs*, December 20, 2017. [http://jcpa.org/chinese-troops-arrive-syria-fight-uyghur-rebels/#\\_edn2](http://jcpa.org/chinese-troops-arrive-syria-fight-uyghur-rebels/#_edn2). Arabi Souri, "Chinese Night Tigers Special Forces Arrive in Syria," *Syria News*, December 16, 2017. <http://www.syrianews.cc/chinese-night-tigers-special-forces-arrive-syria/>. Alex Christoforou, "Des Unités d'Élites Chinoises d'Opérations Spéciales pour Aider le Combat d'Assad Contre l'Insurrection Djihadiste - la Chine Nie," *MirastNews*, December 1, 2017. <https://mirastnews.net/2017/12/01/des-unites-delites-chinoises-dop-erations-speciales-pour-aider-le-combat-dassad-contre-linsurrection-djihadiste/>

152. China-Africa Research Initiative, *Johns Hopkins School of Advanced International Studies*, <http://www.sais-cari.org/data-chinese-agricultural-investments-in-africa/>

153. Lourdes Casanova, "The Challenges of Chinese Investment in Latin America," *World Economic Forum*, March 15, 2018. <https://www.weforum.org/agenda/2018/03/latin-america-china-investment-brazil-private-public/>

154. Ronak Gopaldas, "Lessons from Sri Lanka on China's 'Debt-Trap Diplomacy,'" *Institute for Security Studies*, 21 Feb 2018, <https://issafrica.org/iss-today/lessons-from-sri-lanka-on-chinas-debt-trap-diplomacy>. Robert Feldman, "Is China Practicing 'Debt-Trap Diplomacy' in Africa?", *OE Watch*, April 2018.

155. Tim Fernholz, "Eight Countries in Danger of Falling into China's 'Debt Trap,'" *Quartz*, 7 Mar 2018, <https://qz.com/1223768/china-debt-trap-these-eight-countries-are-in-danger-of-debt-overloads-from-chinas-belt-and-road-plans/>

156. Feldman, "Is China Practicing 'Debt-Trap Diplomacy' in Africa?"

157. R. Shapiro, "The Legacy of the Marshall Plan: American Public Support for Foreign Aid," *The Marshall Plan: Fifty Years After*, Europe in Transition: The NYU European Studies Series, Palgrave Macmillan, New York, 2001

158. John Burgess, Fletcher School of Law and Diplomacy, expert on the Law of the Sea. Lynn Kuok, "China Can Learn from Soviet Approach to the Law of the Sea," *Brookings*, 27 March 2018. <https://www.brookings.edu/blog/order-from-chaos/2018/03/27/china-can-learn-from-soviet-approach-to-the-law-of-the-sea/>

159. George V. Galdorisi and Kevin R. Vienna, "The United States and the Law of the Sea Negotiations," *Beyond the Law of the Sea: New Directions for US Oceans Policy*, 1997

160. Kuok, *Brookings*

161. The Chinese Communist Party and the PRC government are almost always aligned in practice, though the two are technically, legally, organizationally distinct.

162. HQDA, ADP 3-0 Operations (Washington, DC: The Pentagon, October 2017), 7. Consolidate Gains are the "activities that set the conditions for a stable environment."

163. HQDA, *FM 3-07 Stability* (Washington, DC: The Pentagon, June 2014), p 1-2. Civil security is the provision of security for state entities and the population, including protection from internal and external threats (para 1-7).

164. *Ibid.*, 1-2 - 1-3.



**U.S. ARMY**

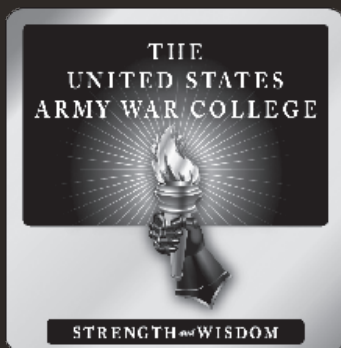

FOR THIS AND OTHER PUBLICATIONS, VISIT US AT  
<http://pksoi.armywarcollege.edu>



This Publication



PSKOI Website



USAWC Website

**ISBN-13: 978-0-9981473-9-0**