

U.S. Army Heritage and Education Center

Historical Services Division

“Come As You Are” War: U.S. Readiness for the Korean Conflict

Conrad C. Crane, PhD
Chief, Historical Services Division

Michael E. Lynch, PhD
Senior Historian

Jessica J. Sheets
Research Historian

Shane P. Reilly
Contract Research Analyst



THE UNITED STATES ARMY WAR COLLEGE

This Page Intentionally Left Blank

**U.S. Army Heritage and Education Center
Historical Services Division**



Prepared By:
Conrad C. Crane, PhD
Chief, Historical Services Division

Michael E. Lynch, PhD
Senior Historian

Jessica J. Sheets
Research Historian

Shane P. Reilly
Contract Research Analyst

**“Come As You Are” War:
U.S. Readiness for the Korean Conflict**

Executive Summary

Task Force Smith at the beginning of the Korean War has often been used as a metaphor for military unreadiness. While the story of that first US action of the war provides a timeless cautionary tale for commanders, the story of unreadiness for war in June 1950 went much further than the tactical failures of one infantry battalion. The lack of readiness was caused by a very disruptive interwar period that saw drastic and often chaotic changes to Doctrine, Organization, Training, Materiel, Leadership, Personnel, Facilities and Policy (DOTMLPF-P).

This case study examines the political, economic, military, and strategic environment in the years between 1945 and 1950 to illustrate the complexity of the readiness issue. Readiness in the strategic context concerned many more issues than simply personnel status or equipment availability. While examining the reasons for unpreparedness at the beginning of the Korean War, one must consider four questions.

Points to Consider:

1. *Readiness for what?* What materiel would the nation most likely need to prepare for war, and where? What are the nation's strategic priorities? What are the most likely v. most dangerous potential enemies?
2. *Readiness of what?* What does the available force look like? What should it look like, given the strategic priorities? How do end strength and force structure affect readiness?
3. *Readiness for when?* What are the events and policies that affect readiness? How does the Army address its posture?
4. *Readiness with what?* What resources are available to build the force and sustain readiness?

This case study examines these issues using the Korean War as an example to illustrate the many factors that affect readiness, and how they combined to send the United States to war unprepared. This study is arranged to support the three classes that constitute Readiness Block IV. Each section stands alone, but each provides context for the others.

Postwar budget cuts are not a new concept, and the reductions after World War II were necessarily dramatic. Yet the lack of readiness in 1950 stemmed from much more than just a cost-conscious President and a parsimonious Congress. The first section, *Strategic Readiness*, surveys the American national security posture in the wake of World War II as President Harry S. Truman grappled with the growing Cold War and the United States' role as a new superpower. The Truman Doctrine sought to use the nation's economic might to assist weaker allies resisting the spread of communism and Soviet influence, thus eliminating the need to deploy US forces. The Truman Doctrine guided future policy and strategy for decades to come, though US forces did deploy for many decades in Europe.

The National Security Act of 1947 brought large changes to the armed forces, separating the Air Force from the Army and establishing it as an independent branch of the newly-created National Defense Establishment (NDE), and creating the Joint Chiefs of Staff (JCS) and the National Security Council (NSC). NSA 1947 also aimed at defense savings through consolidation of procurement, and Congress passed several important pieces of legislation that guided the Defense Department's development and production of material. That legislation and amendments shaped how the President and the defense establishment (later DOD) addressed the nation's strategic posture.

As the atomic age dawned, the United States found itself leading the "free world" with multiple potential enemies. The growing Cold War with the Soviet Union provided the major focus for potential war plans, and shifted the strategic emphasis toward Air Force-dominated nuclear war. A new Unified Command Plan (UCP) assigned priorities in the Pacific to protect allies and guard against Soviet or Chinese backed aggression, though saving the Nationalist Chinese became impossible. Korea, having established a new government under a democratically elected president, seemed to provide an opportunity for the United States to pull back to focus in other areas.

Despite dwindling budgets and steady pressure on the Pentagon to reduce more, world events began to shift the focus of the National Security Council and policy planners. Within a period of about 18 months, the Soviet Union blockaded Berlin and detonated its first atomic bomb; Chinese Communist forces defeated the Chinese Nationalists and forced them to retreat from the Chinese mainland to the island of Formosa; the Soviet Union created the German Democratic Republic; and the USSR signed a Treaty of Friendship, Alliance and Mutual Assistance with the new Chinese government. The National Security Council produced a study titled "A Report to the National Security Council by the Executive Secretary on United States Objectives and Programs for National Security" (NSC-68), which drove the US policy of containment for the next four decades.

The second section, *Defense Sustainment*, studies the nation's capability for industrial mobilization, which turned out to be less than its capacity. Neither government nor industry leaders had planned for future war after the end of World War II. The US nuclear monopoly and two oceans seemed to provide security, and allowed American industry to immediately begin focusing on producing durable consumer goods. Prosperity and full employment greatly affected the war effort, inhibiting the Army's ability to recruit both soldiers and civilians. The industry the military needed at the beginning of the Korean War was fully engaged in business more profitable than government contracts.

NSA 1947 had also created new organizations for mobilization planning: The Munitions Board was responsible for planning for the military aspects of industrial mobilization, while the National Security Resources Board (NSRB) programmed for the effective use of the nation's natural and industrial resources for military and civilian needs. Despite a widespread belief that the United States has always been self-sufficient, there are many strategic and critical materials for which the United States has always depended on foreign sources. During World War II, the government had developed a Controlled Materials Plan designed to ensure access to materials that must be imported in whole or in part from overseas. That plan had lapsed after the war, so there was no information on available critical materials when the Korean War began in 1950. The United States was already a large consumer of raw materials, having consumed one third of the world's production of nonferrous metals before World War II.

Some of the purely military industries that had expanded greatly during World War II struggled to remain afloat given reduced peacetime demands after the war. Some factory owners had bought machine tools from the government at bargain prices after the war, which enabled them to survive as they shifted to production of durable consumer goods. Other booming industries such as the automobile manufacturers lured in the most highly-qualified craftsmen and engineers. Most industries were unwilling to divert their profitable plants to war production, offering instead the marginal plants and less efficient producers. No major industry or firm converted from civilian to military production during the Korean War, and armament production was a marginal effort of the country as a whole. Research and development for military capabilities was uneven. The jet airplane and the heavy bomber with greatly extended ranges had supplanted turboprop airplanes, and in a world dominated by nuclear weapons, the needs so the other services received lower priority.

The nation's new collective defense posture also required production of military items for allies around the world. The Mutual Defense Assistance Act allowed World War II weapons currently in use to be rehabilitated and sent to arm allies, allowing the services to purchase more modern equipment. The execution did not follow the plan, however, and US units were often left with old or obsolete equipment.

The *Defense Sustainment* section ends with a short case study on the serious ammunition shortage that developed during the Korean War. The transition from a wartime to a peacetime economy and austere budgets had affected ammunition

production but the Army's systems for procuring, maintaining, reporting, forecasting, and accounting for ammunition were also broken from top to bottom.

The third section, *Force Generation*, examines the effects of a large and rapid demobilization after World War II. While this case study has attempted wherever possible to present the joint picture, the magnitude of the Army demobilization and subsequent rapid mobilization and deployment for the Korean War best illustrate the problems of the nascent Defense Department. The American public did not see the utility of a large standing Army at the end of World War II, and yearned for the troops to be demobilized. The public demanded the government "bring the boys home."

By 1950, the Army had been reduced to ten divisions, none at full strength, and the Marine Corps was a shell of its former self. The postwar occupation mission in Europe and Japan had largely given way to constabulary operations designed to maintain internal security in the occupied nations. The force structure was also greatly reduced, with one battalion of each infantry regiment inactivated. The end of World War II had also brought a return to a peacetime training focus. This training deficit became apparent during the Korean War, when undermanned, underequipped, and undertrained units were rushed to South Korea in response to the North Korean invasion.

Three of the units that deployed to Korea in September and October 1950 illustrate the difficulties that the new Department of Defense, and especially the ground forces, experienced in deploying to a "come as you are" war. The 7th Infantry Division needed more than 8,000 Korean draftees to fill its ranks, in a program called Korean Augmentees to US Army (KATUSA). The 1st Marine Division contained only one infantry regiment when it was alerted to deploy to Korea. It landed at Inchon on September 15, 1950, with only two regiments intact; the third regiment joined the division later. The 3rd Infantry Division was so short of personnel that it inactivated one regiment to fill the other two. Like the 1st Marine Division, the 3rd Infantry Division landed at Wonsan on the East Coast in October 1950 with only two regiments; a separate regiment arrived to fill out the division's complement.

This case study provides a look at readiness from the national level. Every aspect of the environment known today as DOTMLPF-P changed during the years 1945-1950. The problems these units experienced were not isolated incidents, nor were they caused by inadequate commanders. They were the result of a confluence of domestic and international policies, political and strategic decisions, and economic forces that were themselves products of a changing world.

Table of Contents

Executive Summary	i
Introduction.....	1
Points to Consider:.....	1
Strategic Readiness.....	3
<i>Preparedness: Political Realities</i>	3
Truman Doctrine and the Fair Deal	3
National Security Act of 1947	4
Budget Reductions.....	6
<i>Preparedness: Strategic Priorities</i>	6
Europe.....	6
Japan.....	8
Formosa.....	9
Korea.....	10
NSC-68	10
Defense Sustainment	12
<i>Economic Realities</i>	13
<i>Political Realities</i>	14
<i>Strategic and Critical Materials</i>	16
Figure 1 - U.S. Strategic and Critical Imports	17
<i>Production Realities:</i>	18
<i>Strategic Priorities</i>	19
<i>Research and Development</i>	19
<i>Mutual Defense Assistance Program (MDAP)</i>	20
<i>Production Case Study: Ammunition Shortage</i>	21
Force Generation	23
<i>Force Reduction</i>	23
Figure 2 - U.S. Army Active Duty End Strengths, 1940-1949	23
<i>Force Readiness: Forces in Being</i>	24
Figure 3 - Infantry Regimental Structure, 1950	25
Training Shortfalls	26
<i>Force Generation</i>	28

Figure 4 - Regular Army Divisions, June 1950 29

Figure 5 - Divisions Assigned to Occupation Duty in Japan..... 31

Figure 6 - National Guard Units Activated during the Korean War..... 33

Force Deployment..... 34

 7th Infantry Division..... 34

 1st Marine Division 35

 3rd ID/65th Regimental Combat Team..... 35

Conclusion..... 37

Introduction*

On June 25, 1950, U.S. Ambassador John J. Muccio called from Seoul to alert General Headquarters (GHQ), Far East Command (FECOM) in Tokyo that the North Korean People's Army (NKPA) had attacked in force across the 38th Parallel, the arbitrary line separating North Korea from the Republic of Korea (ROK). Muccio said the attack included large formations of infantry and aircraft. General of the Army Douglas MacArthur, Commander in Chief, Far East Command, received the news shortly after 10:30 A.M. He later noted in his memoir that the news made him feel like he must be dreaming.

The American response to the North Korean invasion resembled previous experiences at the start of a war: unpreparedness and initial defeat. North Korea, a very small military power, had exposed a hollow Army far worse than at the start of World War II. The Joint Chiefs of Staff authorized MacArthur to send one American regiment to Korea immediately, and after initial hesitation, cleared him to send more formations to stabilize the South Korean army. MacArthur ordered Eighth U.S. Army Commanding General LTG Walton Walker to deploy one stripped-down infantry battalion and one artillery battery to Korea as quickly as possible. A shortage of transportation forced the Eighth Army to deploy to South Korea in piecemeal fashion, and proximity dictated that the 24th Infantry Division units should go first. After dispatching the 1st Battalion, 21st Infantry (later designated Task Force Smith after its commander, LTC Brad Smith) on July 1, Walker began stripping other units from the Eighth Army to bring 24th Infantry Division up to full strength. Task Force Smith, later used as a metaphor for unreadiness, fought credibly against great odds but was quickly overwhelmed in the first American battle of the Korean War.

The unpreparedness for war went much further than the tactical failures of one infantry battalion. The lack of readiness was caused by a very disruptive interwar period that saw drastic and often chaotic changes to Doctrine, Organization, Training, Materiel, Leadership, Personnel, Facilities, and Policy (DOTLMPF-P).

Points to Consider:

An examination of the reasons for unpreparedness at the beginning of the Korean War must consider four questions for readiness:

5. *Readiness for what?* What would the nation most likely need to prepare for war, and where? What are the nation's strategic priorities? What are the most likely v. most dangerous potential enemies?

* Portions excerpted from Michael E. Lynch, *Edward M. Almond and the U.S. Army: From the 92nd Infantry Division to the X Corps* (Lexington, KY: University Press of Kentucky, publication forthcoming), used by permission.

6. *Readiness of what?* What does the available force look like? What should it look like, given the strategic priorities? How do end strength and force structure affect readiness?
7. *Readiness for when?* What are the events and policies that affect readiness? How does the Army address its posture?
8. *Readiness with what?* What resources are available to build the force and sustain readiness?

This case study examines these issues using the Korean War as an example to illustrate the many factors that affect readiness, and how they combined to send the United States to war unprepared.

Strategic Readiness

Preparedness: Political Realities

The years between World War II and the Korean War were tumultuous, as the nation and the armed forces adapted to the new realities of the postwar world. Demobilization, declining budgets, and America's role as the new leader in a developing Cold War forced changes in how the armed forces planned and operated. During this period, the armed forces began the first real steps toward joint planning and operations. Moreover, the changed world environment forced the United States to begin developing coherent preparedness postures. There was no National Security Strategy, National Military Strategy, or Defense Planning Guidance as they would be understood today, but the beginnings of those strategies became clear through the publication of National Security Council policy memos.

Truman Doctrine and the Fair Deal

President Harry S. Truman set the course for future American overseas engagement in early 1947 in response to a plea for financial, economic, and technical assistance from the Greek government. Fearing the growing Soviet-backed Communist influence in both Greece and Turkey, Truman addressed a joint session of Congress in March 1947 to request financial and limited military assistance to both countries. Truman acknowledged that the United States could not militarily prevent the Soviets from taking over strategic areas of the world, but the U.S. could help weaker nations help themselves. His policy depended upon the cooperation of those weaker nations, and he intended to use the might of the United States' economic resources rather than military force. Those nations would then, of course, remain in the American sphere of influence, become trading partners, and potential future military allies. This policy became known as the Truman Doctrine, and it guided future policy and strategy development. Truman saw his policy as fiscally responsible. Even though it would cost money to assist other countries, he believed that would be much cheaper than funding a large military.¹

Truman's policy was grounded in the nation's capacity (and willingness) to assume its new role as a world power and military capabilities and funding the Fair Deal. Truman's Fair Deal, seen as an extension of President Franklin D. Roosevelt's New Deal, pushed for government-funded initiatives (health care, education, public housing) as well as a minimum wage increase and civil rights laws. He proposed his initiatives to a Joint Session of Congress in January 1949, and it took time for some of his proposals to see success. By 1951, a Housing Act had been passed, the National Science Foundation was formed, and Social Security had been amended.

Truman focused his post-World War II government on fiscal constraint, with a distrust bordering on disdain for the military. Truman had gained renown as a fiscal conservative, especially toward the military. While serving in the U.S. Senate during World War II, Truman had chaired the Special Committee on Investigating the National

Defense Program (later called the Truman Committee). The Committee was established in 1941 to provide oversight to defense contracting in the War and Navy Departments to prevent fraud, waste, and abuse. Truman did not trust military leadership to be frugal with the nation's purse:

I do know from my experience that . . . no military man knows anything at all about money. All they know how to do is to spend it, and they don't give a damn whether they're getting their money's worth or not. There are some of them . . . I've known a good many who feel that the more money they spend, the more important they are. That's because of the education they get. I told you. It's like putting blinders on a man. He can't see on either side of him, and he can't see ahead of him beyond the end of his nose.²

Many people, especially in Congress and the Truman Administration, felt after World War II that the armed forces were too large, too costly, and too profligate with their budgets. The American people were unhappy over taxes and wanted a reduction in government spending, so a reduction in the force was inevitable. Congress also wanted the military to use its large excess of supplies and materiel before buying more, which is a reasonable argument. The result was a determined effort to force economies on the operation of the military. Unfortunately, the services did little to counter this perception, and there is ample evidence of waste.³

National Security Act of 1947

The armed forces changed dramatically with the new National Security Act of 1947 (NSA 1947), which Truman signed on July 26. The NSA separated the Air Force from the Army and established it as an independent branch of the newly-created National Defense Establishment (NDE), which included the Army and the Navy. The act codified the service chiefs as the Joint Chiefs of Staff (JCS) and created the position of the Chairman. The Commandant of the Marine Corps was not a full member of the JCS, but attended meetings of the Joint Chiefs when Marine matters were under discussion. President Truman had been unhappy with the flow of intelligence during the last months of World War II as he assumed the presidency, and in the immediate post-war years. The Act, therefore, included authorization of a Central Intelligence Agency, in which the Director of Central Intelligence would pull together all available information to provide to the President. The Act also created the National Security Council (NSC), which was designed to pull all National Security leaders together. The NSC began producing reports and studies which guided American strategies. The Chairman represented the JCS on the NSC.⁴

The NSA 1947 designated a Secretary of Defense (SECDEF) to head the NDE and a service secretary to head each department. The NDE, however, was not a department, as were the Departments of the Army, Navy, and Air Force. It was a "federated" arrangement with the Secretary having no real authority over the three departments; he merely operated to coordinate the activities of the other three. The armed services within the NDE retained executive authority and the SECDEF remained

powerless to resolve inter-service disputes. Moreover, the first Secretary of Defense, former Secretary of the Navy James G. Forrestal, had actively opposed unification of the services and creation of the Air Force, reflecting a Navy attitude that would soon cause trouble within the defense establishment. An amendment to the act passed in August 1949, however, transitioned the NDE to the Department of Defense (DOD) and gave the SECDEF executive authority over the DOD departments and secretaries.⁵

Use of the atomic bomb at the end of World War II had revolutionized political and military leaders' views of the future of warfare. The new Air Force, with its strategic bombing advocates such as GEN Curtis LeMay, saw a world dominated by nuclear weapons which only the Air Force could deliver. The time for large land armies was believed to be past. Atomic bombs had ended the war, without the need for the planned invasion of Japan, thus saving countless American lives. In a newly nuclear world, where the United States initially had the only atomic capability, political and military leaders believed that the threat of, and capability to, drop atomic bombs on an enemy saved American lives by deterring war or ending it quickly. There was, therefore, no need for a large, expensive, standing Army. Moreover, this also tended to push the nation toward technological solutions. Atomic bombs were very expensive, but theoretically cheaper in the long run than conventional forces. Atomic bombs could be produced and then stored for use, perhaps for many years. Conventional forces needed constant recruiting and conscription for personnel, and continual modernization of equipment.

Most of the roles and missions discussion, however, centered on the nuclear mission. The Air Force believed it had primacy, but the Navy also sought a role. The Air Force designed a super bomber, the B-36, arguing that this bomber could deliver nuclear weapons anywhere in the world, thus making the other services less strategically relevant. The Navy, however, had designed a flush-deck "supercarrier," USS *United States*, which was intended to carry heavier aircraft capable of dropping atomic weapons. This competition for the nuclear mission caused tensions between the Navy and the Air Force, which saw the nuclear mission as its own. The prominence of strategic bombing caused greater problems for the Army both because of the reduced role of ground forces in future conflict, and the decreased emphasis on the close air support mission.

President Truman issued Executive Order 9877 (July 26, 1947) giving responsibility to the Army for airborne and joint amphibious operations. This rankled the Marine Corps, which considered amphibious operations as its exclusive mission. Secretary of Defense James V. Forrestal met with the JCS in March 1948 in Key West, Florida, to identify specific roles and missions for each service, resulting in a report titled *Functions of the Armed Forces and the Joint Chiefs of Staff*, which became known as the "Key West Agreement." The agreement left control of joint airborne operations to the Army, but gave joint amphibious missions to the Marine Corps. Each service was allowed develop its specific capabilities, but had to subordinate its operations to the controlling service in joint operations. One of the divisive aspects of the unification plan was that Truman and others saw no need for a duplication of forces, such as a separate

Marine Corps, when the Army could fill the ground combat role. There was discussion about merging the Marine Corps into the Army or eliminating it altogether. Likewise, the Navy's fleet air arm was believed to be redundant with the Air Force.⁶

In October 1949, GEN Omar N. Bradley, then serving as Chairman of the Joint Chiefs of Staff, gave contentious testimony to the House Armed Services Committee:

If I may digress for a moment from my consideration of the atomic bomb. I would like to point out to those who hold that a tremendous Marine Corps is essential for future amphibious operations, and the Naval Air must be correspondingly large, that I have participated in the two largest amphibious assault ever made in history. In neither case were any Marines present. And in neither case were any Navy carriers used.⁷

Budget Reductions

One of the primary reasons for unification was consolidation of procurement. In addition to NSA 1947, Congress passed several important pieces of legislation that guided the Defense Department's development and production of material. These included the Armed Services Procurement Act of 1947, which overturned old single service procurement statutes and set the stage for coordination of all procurement across the services. The Defense Production Act authorized the establishment of a system of priorities and allocations of critical materials for defense uses, and provided assistance for expansion of production capacity.⁸

When Louis Johnson became Secretary of Defense in 1949 he began looking for economies immediately. He believed he could save billions of dollars without any real harm to the security of the country, and explored every possible option for quick savings. During that last year before the Korean War, he questioned sharply any request for money and regarded requests for increases in funds as almost disloyal.⁹

Preparedness: Strategic Priorities

Europe

War planning during World War II had shown the JCS that the future of the American armed forces lay in joint operations, and those experiences laid the groundwork for unification. As the Army and Navy, and to a lesser extent the new Air Force, wrangled over declining budgets, each service worked to secure its future through defining missions. The growing Cold War with the Soviet Union provided the major focus for potential war plans, and shifted the strategic emphasis toward Air Force-dominated nuclear war. The services began movement toward more joint or unified planning with the formation of the Joint War Plans Committee (JWPC; later Joint Strategic Plans Group) in March 1946. In August 1947, the JWPC began developing war plan BROILER, which assumed a Soviet attack on the United States within the next 3 years. The premise of that plan was to launch a strategic air offensive against the

USSR from North America, the UK, and the Cairo Suez area. The JWPC conducted a series of strategic studies titled PINCHER in 1949 that laid the ground work for a joint war plan.¹⁰ A longer-range plan, CHARIOTEER, plan for a war with the Soviet Union by 1955, but assumed the loss of Western Europe and the need for a massive atomic strategic air campaign. With the large number of Soviet ground forces, planners believed that a ground offensive could not be launched to recover Western Europe before D+ 10 months. Though neither one of these plans reached full fruition, they provided the basis for many future plans. Most plans assumed use of strategic bombing and nuclear weapons, but U.S. intelligence estimates believed that the Soviet Union would not have the atomic bomb before at least 1949.¹¹

Most plans, therefore, envisioned large fleets of long-range bombers, with large numbers of troops to be mobilized later. In considering the budget for fiscal year 1950 in the fall of 1948, however, the JCS realized that their strategies needed to conform to the austere budgets imposed by the Truman administration. The preparation for the new plan, which would be called OFFTACKLE, foundered on three major issues, the first two of which would have far-reaching implications:

- Degree of reliance on strategic bombing
- Participation of carrier aircraft in the strategic attack
- Importance of the UK as base for operations¹²

OFFTACKLE focused only on the initial stages of the war with the USSR, and NSC guidance did not require the Joint Chiefs to plan for military operations to force the surrender of the Soviet Union nor were they required to prepare for military occupation and for governing former Soviet territory. The strategic air offensive was designed to destroy Soviet war making capability and would include both atomic and conventional bomb attacks on petroleum refineries, electric power plants, submarine construction facilities, gasoline production facilities, and other war industries. The plan included four objectives:

- Disruption of Soviet industry
- Elimination of the political and administrative controls of the Soviet government over its people
- Undermining the will of Soviet government and people to continue the war
- Disarming of the Soviet Armed Forces¹³

OFFTACKLE addressed defenses in the Far East only briefly, with retaining Okinawa as the major objective in order to provide a base for the defense of Japan. Joint staff planners grappled with steeply declining budgets as they first addressed problems in Europe and the Middle East before turning to Asia. Within Asia, several issues ranked ahead of Korea on the scale of strategic problems, including the security of Japan, the Chinese threat to Formosa, a war in French Indochina, a new alliance between China and the USSR, and the possibility of war between China and India. Defenses of Taiwan, the Philippines, and other islands would be left to the limited forces in Far East Command.¹⁴

The JCS in 1947 began developing a longer-range plan for mobilization for a longer war, called COGWHEEL. The development of mobilization plans exposed further disagreements among the services. The plan envisioned a phased deployment of armed forces that might become available during the first twenty-four months of a war beginning on July 1, 1949. The newly-formed Munitions Board used COGWHEEL for mobilization planning, but found that the initial plan exceeded the nation's capacity for man-made manufacturing and induction of manpower. As the JCS began to revise COGWHEEL, the Munitions Board revised the mobilization plan based on half of the requirements generated by COGWHEEL.¹⁵

As if to prove to the West that the USSR presented a clear and present danger, in June 1948 the Soviets blockaded Berlin. The city had been occupied after World War II jointly by the four Allied powers that also occupied the remainder of Germany. The city lay wholly within the Soviet sector, however, and the Soviets blocked all road and river access. The Allies launched the Berlin Airlift two days later to sustain the civilian populace of the city, but the incident underscored the need for collective security. The Treaty of Brussels in March 1948 linked the United Kingdom, France, Belgium, the Netherlands, and Luxembourg in a treaty of mutual defense, forming an organization known as the Western European Union (WEU). The Europeans, especially the British, were anxious that the U.S. join European collective security arrangements, but the U.S. government was not as enthusiastic. The Marshall plan was under discussion in Congress, and the administration wished to wait for finalization of that plan before beginning discussions on further commitments. The National Security Council studied the issue and developed a new policy paper, NSC 9/3, which President Truman approved. NSC 9/3 opened the door for the U.S. to begin treaty discussions of the nations of Western Europe, but also established two conditions for the European powers to receive U.S. arms aid:

- They must plan their coordinated defense with means presently available.
- They must determine how their collective military potential be increased by coordinating production supply and standardization of equipment.¹⁶

After much negotiation and discussion, twelve nations signed the North Atlantic Treaty in Washington on April 4, 1949. The U.S. and Canada joined Iceland and the European nations of Belgium, Denmark, France, Italy, Luxembourg, the Netherlands, Norway, Portugal, and the United Kingdom. Article 5 of the treaty provided the cornerstone for military planning, stating that an armed attack against one or more of the nations in Europe or North America should be considered an attack against them all. The Soviets ended the Berlin Blockade one month after the signing of the treaty, but the Western strategy for collective security remained in place.¹⁷

Japan

The JCS had created a new Unified Command Plan (UCP) in 1946 to eliminate squabbles in the Pacific between the Army and the Navy, and to assign areas of responsibility in the rest of the world. Army Forces Pacific (AFPAC) was re-designated

Far East Command (FECOM) on January 1, 1947, with the Army Chief of Staff as executive agent, making it an “Army” theater. FECOM was a unified rather than pure a joint command, which meant that Commander in Chief General of the Army Douglas MacArthur commanded the theater through the senior commanders of the other services. MacArthur’s subordinate U.S. commands included U.S. Eighth Army; Headquarters and Service Group, GHQ; Ryukyus Command (RYCOM); Marianas-Bonins Command (MARBO); U.S. Thirteenth Air Force; U.S. Naval Forces Far East (NAVFE), and U.S. Far East Air Forces (FEAF). The Joint Chiefs expected MacArthur to support U.S. policies in the areas he controlled, and to prepare to meet a general emergency at any time.¹⁸

Formosa

At the end of 1948, Chinese Communist forces were clearly winning the civil war against the Nationalists, and the U.S. began seriously reconsidering its policy toward assisting Chiang Kai-shek. There was little the United States could do to influence the situation, nor could it assist the Nationalists in any meaningful way, so the basic policy aimed at merely preventing China from becoming a Soviet satellite. China, accordingly, dropped lower on the scale of strategic priorities.¹⁹

By April 1949, the National Military Establishment and the Truman administration were considering not what aid it could provide to the Nationalists, but rather what aid it should provide. The administration did not want to desert the Nationalists in their greatest hour of need, but also did not want to provide military equipment only to see it falling to the hands of the Communists. After the Nationalist government evacuated mainland China and moved to Taiwan (formerly Formosa) in October 1949, the U.S. remained in a difficult position. The director of the Joint U.S. Military Assistance Group China (JUSMAGCHINA) argued that the Nationalist collapse resulted from “a weak and unstable government which was over centralized; which had little or no popular support; and which had as a primary interest the protection of the privileged class.”²⁰

The Truman administration decided to furnish economic assistance to Taiwan without committing any military forces to the island, but the Joint Chiefs remained concerned. They argued that “a modest, well-directed and closely-supervised program of military aid to the Chinese Nationalist government in Taiwan would be in the security interest of the United States.” The JCS saw this as a “part of the overall problem of resisting the spread of communist domination in East Asia.” After much deliberation, President Truman announced the new policy with respect to Taiwan (NSC 48/2) on January 5, 1950:²¹

The United States government will not provide military aid or advice to Chinese forces on Formosa. In the view of the United States Government, the resources on Formosa are adequate to enable them to obtain the items which they might consider necessary for the defense of the Islands. The United States Government proposes to continue under existing legislative authority the present ECA [Economic Cooperation Administration] program of economic assistance.²²

This policy remained in place until June 1950, but after the North Korean attack, the U.S. moved naval forces to the Straits of Taiwan to protect the island from potential Chinese aggression.

Korea

Unlike the other occupied nations that had been conquered and their governments destroyed or subjugated, Korea had been liberated from Japanese rule. U.S. forces occupied Korea with a view toward assisting the Koreans, who had lived under forced Japanese rule for 40 years, establish their own government. With U.S. defense strategy focused primarily on the Soviet Union with a secondary interest in China, the Korean peninsula assumed an economy of force role. President Truman put the matter to rest in April 1948, approving the policy document that defined U.S. intent on the peninsula:

The United States should not become so irrevocably involved in the Korean situation that an action taken by any faction in Korea or by any other power in Korea could be considered a "casus belli" for the United States.²³

In May 1948, Syngman Rhee was elected president in South Korea's first free election. Rhee declared the Republic of Korea independent when he assumed office on August 15, 1948, and the United States officially ended the occupation. MG John Hodge, XXIV Corps, transferred control of the new government to Rhee and his officials and began moving Soldiers out of Korea to Japan in September. The XXIV Corps headquarters departed in January 1949 and deactivated in Japan. John J. Muccio arrived as the U.S. envoy to South Korea on August 27, 1948, and became the ambassador when the United States formally recognized the Republic of Korea in 1949. The fledgling South Korean government was not yet ready for full independence, however, so a small contingent (500) of U.S. Soldiers remained as the Korean Military Advisory Group (K MAG). With the Republic of Korea established as a sovereign nation, the U.S. re-focused its attention to many other areas of concern, primarily Europe.²⁴

NSC-68

Despite dwindling budgets and steady pressure on the Pentagon to reduce more, world events began to shift the focus of the National Security Council and policy planners. In September 1949, the Soviet Union detonated its first atomic bomb, ending the perceived safety of the American monopoly on nuclear weapons. The following month, Communist forces under Mao Tse-tung declared victory over the U.S.-backed Chinese Nationalist forces under Chiang Kai-shek and established the People's Republic of China. Chiang Kai-shek's forces retreated from the Chinese mainland to the island of Formosa. Just days later, the Soviet Union created the German Democratic Republic, solidifying the division of Germany that would last until 1991. When the USSR signed a Treaty of Friendship, Alliance and Mutual Assistance with the new Chinese government in early 1950, Truman reluctantly agreed to a re-appraisal of the nation's military capacity and policies. The National Security Council produced a study titled "A

Report to the National Security Council by the Executive Secretary on United States Objectives and Programs for National Security” (NSC-68). The report determined that, based on current and projected nuclear capability, the Soviet Union should be able to launch a preemptive nuclear strike by 1954. This became the Year of Maximum Danger, and the focus for future planning.²⁵

NSC-68 drove the U.S. policy of containment for the next four decades against global communism, but Truman saw it as an unnecessary strategy requiring large defense budgets, in a time when the country was attempting to recover from a brief postwar recession. Truman was also concerned about the amount of influence military leaders wielded, and he saw mobilization and defense planning as ways to increase that influence. This disagreement among government officials led to a degree of strategic drift, as the civilian leadership failed to identify and prioritize potential threats, and failed to fund military training appropriately.²⁶

This Page Intentionally Left Blank

Defense Sustainment

Neither the U.S. government nor industry leaders saw a need to begin planning immediately for future war after the end of World War II. The U.S. nuclear monopoly and two oceans seemed to provide security, and the lack of damage to the nation's industrial plants, compared to what European industry had suffered, allowed American industry to immediately begin focusing on production of durable consumer goods. Many feared that the immediate reduction in government spending after World War II, combined with the demobilization of millions of men, would create a recession. There was an economic downturn for a few months after the war, but the quick shift of industry back to a peacetime economy, "metering" the demobilization, the GI Bill, and the hunger for consumer goods after years of war shortened the recession period. Unemployment fluctuated, but remained low between the wars. This prosperity and full employment also affected the Army, which needed to expand its civilian force but competed with industry for the relatively small number of unemployed. On September 3, 1946, Congress released report that recalled the complacency of various branches of government, as well as the military, in regard to national defense in the twenty years preceding World War II: "The support of our national defense [was] reduced to a dangerous minimum. . . . This Nation should not again make the same costly error."²⁷

The outbreak of the Korean War exposed severe shortages in materiel, both in quality and quantity, and revealed problems with industrial responsiveness at all levels. The lead-time between negotiation, manufacture, and delivery of basic equipment was approximately eighteen months -- and longer for advanced items, such as tanks. Despite production line efficiency, the quality and safety of all equipment was of utmost concern, lengthening production time of even the most seemingly basic "precision instruments" of war.²⁸

Economic Realities

By 1950, the postwar recessions were over and the country as a whole was prosperous. This prosperity greatly affected the war effort. At the beginning of World War II the nation was coming out the Great Depression with large unemployment and idle industries looking for business. That environment enabled the nation to quickly build a wartime industry. The industry the military needed at the beginning of the Korean War was fully engaged in business more profitable than government contracts. The Korean War provided an emergency situation, but the scope and scale were much smaller than World War II. At the peak of World War II in 1944-45, defense expenditures amounted to 45 percent of the gross national product. By April 1951, the number was 8 percent, expected to grow to 15 percent by the end of 1951 but not to exceed 20 percent at the height of production.²⁹ Industrial production rose more than 12 percent in the first year of the Korean War, and the gross national product rose by another 9 percent. Similar or higher increases were expected for the next 2 years. For the first nine months of fiscal year 1951, the Department of Defense obligated over \$23 billion (\$220.7 billion in 2017 dollars) out of a total of \$32 billion (\$307 billion) in the defense budget. More than \$1 billion (\$9.5 billion) of that was used for stockpiling strategic materials.³⁰

This Page Intentionally Left Blank

Political Realities

In addition to the reorganization of the Armed Forces, NSA 1947 had also created two organizations that were critical to mobilization planning. First, the Munitions Board, which consisted of a civilian chairman and the undersecretaries of the three services reporting directly to the Secretary of Defense, was responsible for the following:³¹

1. Coordination of procurement, production, and distribution plans of the Department of Defense.
2. Planning for the military aspects of industrial mobilization.
3. Assignment of procurement responsibilities among the several military departments, standardization of specifications, and allocation of purchase authority of technical equipment using single procurement.
4. Preparation of estimates of potential production, procurement, and personnel for use in evaluation of logistic feasibility of strategic operations.
5. Determination of relative priorities of the various segments of the military procurement programs.
6. Supervision of relevant subordinate agencies.
7. Regrouping, combining, or dissolving of existing inter-service agencies in the fields of procurement, production, and distribution for efficiency and economy.
8. Liaison with other departments for correlation of military requirements with the civilian economy, in regard to the procurement or disposition of strategic and critical materiel and the maintenance of adequate reserves.
9. Review of materiel and personnel requirements presented by the JCS and by the production, procurement, and distribution agencies, and make recommendations to the Secretary of Defense.

The Board supervised the development of requirements for production of military items, and then coordinated them with the National Security Resources Board (NSRB) the other organization created by NSA 1947. The NSRB also consisted of a civilian chairman and the secretaries of State, Treasury, Defense, Interior, Agriculture, Commerce, and Labor. It reported directly to the President to advise him on all phases of mobilization and:³²

1. Recommend policies concerning industrial and civilian mobilization in order to assure the most effective mobilization and maximum utilization of the nation's manpower in the event of war.

2. Program for the effective use of the nation's natural and industrial resources for military and civilian needs, for the maintenance and stabilization of the civilian economy in time of war, and for the adjustment of the economy to war needs.
3. Recommend policies for unifying the activities of federal agencies engaged in production, procurement, distribution, or transportation of military or civilian supplies, materials, and products.
4. Identify the relationship between potential supplies of and potential requirements for manpower, resources, and productive facilities in time of war.
5. Recommend policies for establishing adequate reserves of strategic and critical material, and the conservation of those reserves.
6. Recommend the strategic relocation of industries, services, government, and economic activities.

The Director of Defense Mobilization, Charles E. Wilson, reported to President Truman in July 1951 on the status of the defense buildup one year after the beginning of the Korean War. Wilson reported that the armed forces had raised a strength of 3,500,000 men, which was more than twice the fighting force when the war began. They formed the equivalent of 24 Army divisions and 2¹/₃ Marine divisions and supporting elements, with a Navy of more than 1,100 ships and an Air Force approaching 95 wings.³³

Strategic and Critical Materials

Despite a widespread belief that the United States has always been self-sufficient, there are many basic minerals for which the United States has always depended on foreign sources (see Fig. 1). The United States was already a large consumer of raw materials, having consumed one third of the world's production of nonferrous metals before World War II. The percentage increased to 40 percent between World War II and the Korean War. The United States had identified many sources of foreign raw materials, and in most cases provided the capital necessary to develop resources or funds for research and transportation. For the first six months of fiscal year 1951, imports of these crude minerals climbed over 26 percent over the 1949 level. The government restricted certain raw materials, but did not ban their use for civilian goods entirely in order to keep consumer goods production relatively high to prevent inflation.³⁴

The government developed a Controlled Materials Plan in 1950, designed to ensure access to materials that must be imported in whole or in part from overseas. A similar one had been used during World War II, but there had been no such plan during the interwar years. There was therefore no information on available critical materials which further delayed shifting to wartime production.³⁵ These critical materials included tin, lead, zinc, and rubber for critical alloying metals such as cobalt, columbium, molybdenum, nickel, and tungsten. Use of these metals was also severely restricted in

civilian industry. Synthetic rubber was already in production in large amounts, but even the combined use of natural and synthetic rubber did not meet defense demands.³⁶

Figure 1 - U.S. Strategic and Critical Imports

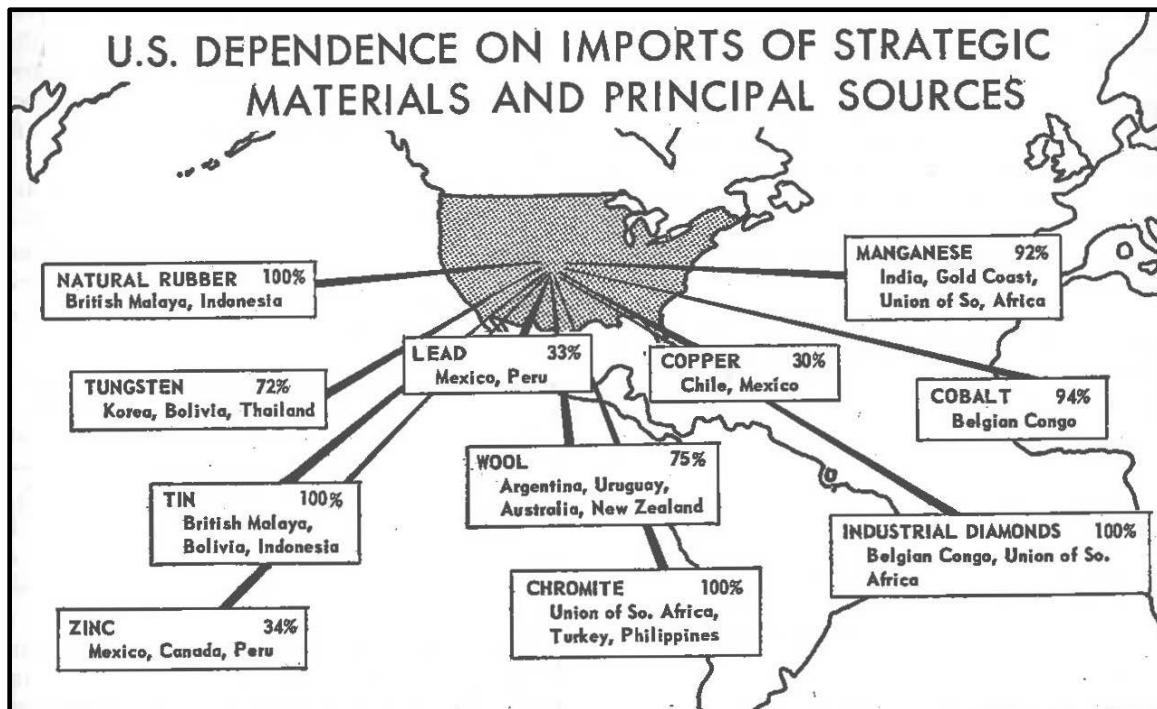

Source: Office of Defense Mobilization, *Report to the President: Building America's Might* (Washington, D.C.: Office of Defense Mobilization, April 1951), 39.

The most critical materials necessary for defense production were, of course, metals. Military requirements claimed 12 percent of the nation's total steel production in the first three months of 1951, and that was expected to reach 20 percent by the end of the year. That increased production, however, masked related difficulties. A shortage of pig iron had required the formation of some 500 scrap mobilization committees which sought to identify 36,000,000 tons of scrap from farms and automobile junkyards. Despite having the highest rate of production for steel in the nation's history, there was no excess capacity available when the Korean War began. The civilian demands for steel at the time exceeded all peacetime records. The large and increasing need for steel extended not just to weapons of war and civilian durable goods such as automobiles, but also the rail lines, rail cars, and cargo vessels needed to carry it and the facilities needed to produce it. In order to increase the capacity of the rail system, freight car production was increasing to 10,000 cars per month.³⁷

Increasing aircraft production placed heavy demands of the industry for aluminum, but this process required large amounts of electric power and the power plants to provide it. The demand for critical chemicals for the production process, such as sulfur and nitrogen, was also high. All of these processes demanded petroleum. The

total daily requirement for oil for military and civilian use amounted to 7.7 million barrels per day, which is 1/3 more than peak usage during World War II. The Petroleum Administration for Defense estimated in 1951 that domestic refining capability needed to be raised to 8 million barrels per day which would require expansion from the well all the way through the system to the refinery. This expansion, would in turn require large amounts of steel. The government objective was to open 43,400 new domestic wells during 1951.³⁸

Production Realities:

Some of the purely military industries that had expanded greatly during World War II struggled to remain afloat given reduced peacetime demands after the war. The Army had, in the years following World War II, sold machine tools obtained from the War Assets Corporation for cut-rate prices, which enabled some businesses to survive as they shifted to production of durable consumer goods. Furthermore, other booming industries such as the automobile manufacturers lured in the most highly-qualified craftsmen and engineers. Most industries were unwilling to divert their profitable plants to war production offering instead the marginal plants and less efficient producers. No major industry or firm converted from civilian production to military production. To a great extent, the armament project was a marginal effort of the country as a whole.³⁹

Most of the difficulties inherent in restarting industrial production for military equipment to support the Korean War came not from the productions itself but from the preparations for production:

- Time needed for acquiring tools, developing procedures, ordering supplies, and making schedules.
- Shortage of engineers, designers, and draftsmen to prepare the production facilities and procedures.
- Shortage of the necessary machine tools to begin production on a large scale.⁴⁰

After World War II, more than 100,000 pieces of production equipment were placed in storage. By 1951, 35,000 had been put back in production. Of the 440 reserve plants maintained by the Department of Defense, 278 were producing defense items and another 66 were being reactivated, but the process was lengthy. For essential materials or equipment, the Defense Department sometimes financed plant extensions or installation of special equipment in private plants. The government maintained ownership of the facilities or equipment, and leased it to the contractor when it was not being used for defense purposes.⁴¹

Strategic Priorities

The Office of Defense Management (ODM) outlined the nation's dual aims as strength in being and capacity to mobilize. Based on the growing importance of collective security, ODM identified the three critical areas of free world strength:

- 1) Western Europe: Strength in being, mobilization capacity, and political stability.
- 2) Middle East and Asia: Political and economic health
- 3) Western Hemisphere: Development of military and economic strength.

Based on these strengths and worldwide requirements, ODM set production priorities as follows:

- 1) Fighting forces in Korea.
- 2) Expanding armed services in the U.S. and in Europe.
- 3) Assistance to other forces helping the U.S. fight communism.
- 4) Reserve stocks intended for the first year of full-scale war.

By April 1951, productive power was building in three areas:

- 1) Stockpiling scarce and critical materials.
- 2) Additional production lines for military goods.
- 3) Addition of basic industrial capacity for both military and civilian production.

ODM set a goal to build 50,000 airplanes and 35,000 tanks per year and 18,000 jet engines per month. Maximum defense production was expected to be reached in 1952.⁴²

Research and Development

Despite all the post-war drawdowns, research and development on military capabilities had not been stagnant. The jet airplane had been replacing turboprop airplanes, with greatly extended ranges. For instance, the B-17 heavy bomber that had been used extensively during World War II weighed 24,700 pounds, with a range of 1,750 miles. The B-36 heavy bomber that caused such friction between the Air Force and Navy weighed 102,500 pounds, but with a range of 10,000 miles. New electronic controls had been designed to compensate for slower human reflexes in the new fast jet fighter aircraft.

On the other hand, the airplanes at the time held more interest and influence than ground forces. No tanks had been manufactured since World War II and the research and development program had not been geared to produce a new tank by 1950. Nevertheless, new tanks were rushed into production as early as December 1950. The NKPA had spearheaded its attack with T-34 tanks with 85 mm main guns that overmatched the U.S. Army's M24 Chaffee. Austerity measures in the defense budget had caused inactivation of all but one of divisions' tank companies, and eliminated the

regimental tank company altogether. With the Pacific secondary in importance to Europe, the few remaining tank units were equipped only with the M-24 Chaffee light tank with 75 mm guns instead of the M4A3 Sherman (medium) or the newer M-26 Pershing (heavy). The divisions deploying from the U.S. came with the heavier M-26 Pershing tank (or the newer M-46 Patton) with a 90 mm gun, but these were in such short supply that the 70th Tank Battalion arrived in Korea in August 1950 with two companies of M-4 Shermans and one company of M-26 Pershings that had been salvaged from displays at Fort Knox. Few units had a “pure” fleet, with most having a mixture of two or more different kinds of tanks. These difficulties were magnified with the lack of enough trained maintenance personnel on hand to repair the tanks. The M-46 Patton was 60 percent more powerful and 50 percent faster than World War II tanks, but it still experienced problem and required several modifications. The NKPA advantage did eventually disappear after the arrival of the Pattons in Korea. The Navy was meeting the short-term emergency by reactivating ships mothballed in 1945, but it too had a new construction program.⁴³

The new weapons were more expensive, of course, and many required some of the critical or scarce materials. The B-36 was almost ten times heavier than the B-17 due to all the added electronics equipment, and cost \$3,500,000 dollars each, thirteen times the \$275,000 cost of one B-17 in World War II. The jet engines operated at much higher temperatures than piston engines, and therefore required much more alloying and heat treating using metals such as tungsten, chromium, cobalt, and molybdenum. The electronics equipment required increased amounts of cobalt, cadmium, zinc, lead, and copper. The Defense Department compensated partially for using these minerals in other areas. For instance, cartridge and shell cases were converted from brass to steel to reduce consumption of copper. Copper and aluminum experienced similar shortages, with the demand for both expected to be more than 20 percent as available supply by the end of 1951. The government was already taking steps to limit steel, copper, and aluminum for civilian use.⁴⁴

Mutual Defense Assistance Program (MDAP)

The nation's new collective defense posture also required production of military items for allies around the world. Congress passed the Mutual Defense Assistance Act in October 1949, which created the Mutual Defense Assistance Program (MDAP). The theory behind MDAP was that World War II weapons in the hands of troops would be rehabilitated and sent to arm allies, while the money allocated for MDAP would be used to purchase more modern equipment for the Army. In theory, the troops would not give up old equipment before the newer equipment was available. In practice, however, the nation needed to be seen to be assisting its allies quickly, so sometimes MDAP materiel was pulled out of service or out of stocks with no ready replacement.⁴⁵

The MDAP provided more than 1 million tons of military equipment to friendly nations beginning in March 1950, not including aircraft and ships delivered under their own power. These included 3,500 tanks and combat vehicles, 11,000 general purpose vehicles, 750 aircraft, 100 vessels and small craft, and 3,000 major pieces of artillery. It

also included small arms, mortars, recoilless rifles, communications equipment, spare parts, and millions of rounds of ammunition. The rate of production of military goods in Western European countries had doubled since the formation of NATO in 1949, and was expected to double again by 1952. U.S. aid was helping make Taiwan self-supporting by easing the strain of a million refugees fleeing the Communists from the mainland.⁴⁶

Production Case Study: Ammunition Shortage

All the production difficulties resulted in shortages in critical areas, but artillery ammunition constituted the most serious shortage during the war. Theater concerns with artillery ammunition stock levels originated in August-September 1951 during operations against Bloody Ridge, then Heartbreak Ridge the following month. Commanders noted the shortages by October 1951, and theater stocks were not adequate until early 1953. The resulting investigation culminated in nine days of hearings into the shortages in the Senate Armed Services Committee. The findings revealed that the transition from a wartime to a peacetime economy had affected ammunition production as much as it had in other areas, and austere budgets had also had deleterious effects. Those external issues aside, however, the investigation also revealed that the Army's systems for procuring, maintaining, reporting, forecasting, and accounting for ammunition were completely broken from top to bottom.⁴⁷

After World War II, the Bureau of the Budget required the Army to use its residual war stocks rather than to buy any items which it already had on hand. This made sense, because the ammunition inventory was unbalanced, without the correct numbers of each type of round to support a given number of troops over time. There might, for example, be many rounds of 105 mm Howitzer high explosive ammunition, but not enough mortar ammunition. Thus the post-war inventory was not useful as a reserve. Had it not been for the inventory imbalances there would probably have been no manufacturer at all of ammunition in the years between World War II and the Korean War.⁴⁸

The ammunition shortage did not occur suddenly -- it resulted from many events over several years. After the end of World War II, the Army had an enormous inventory on hand, but it had insufficient physical means to store it and inadequate numbers of personnel to maintain it. Because of the rush to demobilize, the supply system was neglected, and inventories were inaccurate. In addition, some "lessons learned" affected the inventory. For instance, Army Field Forces had decided, based on the European experience in World War II, that illumination rounds were obsolete. Residual inventories were used up in training after the war and no more rounds were produced. Predictably, these were the first rounds identified as a shortage in Korea.⁴⁹

At the beginning of the Korean War, the Chief of Ordnance estimated he had eight million tons of ammunition on hand, including Air Force bombs. As the Korean War progressed, however, it became clear that there were difficulties merely assuming

raw numbers without reference to specific types. The U.S. also provided the bulk of the artillery for UN forces, the South Koreans having none. A far smaller allocation of guns in Korea than World War II necessitated many more fire missions. The ammunition projections were based on the presence of the much-higher scale of artillery, which calculated to fewer rounds per gun.⁵⁰

The shell shortage rested upon several factors:

- World War II stockpiles were plentiful in the aggregate, but unbalanced in specific quantities by type.
- Hasty demobilization released qualified Ordnance Department personnel, civilian and military, which prevented proper oversight over peacetime training expenditures and quality inspection in long-term storage.
- The cost of ammunition and the belief in a short war encouraged a reliance on existing stocks. American industry in turn was focused on supplying pent-up domestic demand, not expanding munitions production.
- Congress approved the first large appropriation for ammunition in January 1951, which translated to ammunition stocks in theater by late 1952 or early 1953. Billions of dollars in obligated contracts still required six months or longer to see rounds in theater.
- The development of static warfare in Korea accelerated the demand for artillery munitions.⁵¹

Much of the munitions shortage during the early stages of the Korean conflict was exacerbated by the shortage of machine tools. With no ready munitions capacity available after World War II, developing supplies of long lead-time military items such as munitions required two years before adequate supplies were available from production line. Ammunition manufacturing requires a lot of special machinery and many special skills. Large lots of ammunition also needed a great deal of care, which was lacking due to lack of personnel and facilities. In 1949, the Chief of Ordnance determined that there were 5 million rounds of 105 mm ammunition that needed rehabilitation. The end of World War II and the cessation of manufacturing scattered these skills and the machinery to other industries. Because of the very low rate of activity, the ammunition expertise existed only in Army ammunition arsenals. As a result, the outbreak of war in Korea required the re-creation of the ammunition industry.⁵²

The readiness reporting procedures of the time did not alert the Secretary of Defense to a looming problem. Those at lower echelons conducting inventories of existing ammunition stocks assumed that their chain of command understood the potential for shortages, but those at the highest levels did not understand the seriousness of the lack of inventory. The real danger lay in the fact that Korea by December 1951 had absorbed practically all ammunition stocks to fill or even partially fill its theater levels of supply, and Eighth Army was authorized to fire faster than ammunition was being produced. These actions reduced the reserve available for any other emergency and made the situation in Europe more dangerous. If combat had flared anywhere else in the world, the U.S. could have done little about it.⁵³

Force Generation

Force Reduction*

The Army shrank quickly and drastically after World War II, as it had done after the First World War. Americans assumed that “infantry warfare was a thing of the past.” After V-E (Victory in Europe) Day on May 8, 1945, the U.S. Army strength stood at 8.3 million, the largest Army in the nation’s history. The American public did not see the utility of a large standing Army at the end of World War II, and yearned for the troops to be demobilized. The public demanded the government “bring the boys home.” A rapid demobilization began that saw the Army drop to 2 million in 1 year (see Fig. 2). The discharge formula for Soldiers after V-E Day used an Adjusted Service Rating (ASR) score, which assigned points to each Soldier based on length of service, time overseas, combat experience and decorations, number of minor children, and the needs of the Army. After V-J (Victory over Japan) Day (September 2, 1945), however, the process accelerated, with discharges based primarily on length of service. Beginning in January 1946, those with 3.5 years of service were released, dropping to 2.5 years by April, then 2 years in July.⁵⁴

Figure 2 - U.S. Army Active Duty End Strengths, 1940-1949

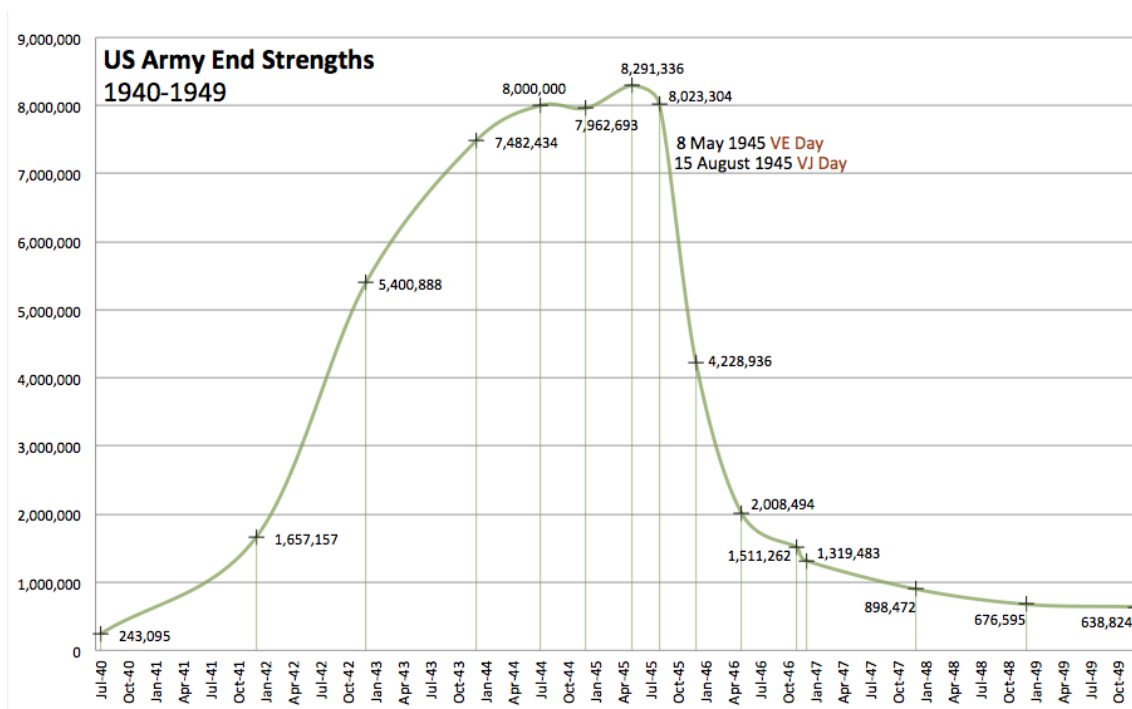

* Portions excerpted from Conrad C. Crane, James D. Scudieri, Michael E. Lynch, and Joe Williams, “Myths of Expansibility: A Study from World War I to the Present” (Case study, Historical Services Division, U.S. Army Heritage and Education Center, U.S. Army War College, 2014).

This Page Intentionally Left Blank

Force Readiness: Forces in Being

By June 1, 1946, the military juggernaut of 89 divisions that had fought to victory in three theaters had been reduced to only 17 divisions on active duty. Four divisions were assigned to occupation duty in Germany, four in Japan, two in Korea, and one each in Austria, Italy, and the Philippines. The remaining four divisions constituted the General Reserve in the United States. The four divisions in Japan were scattered on constabulary missions and reduced in strength. Within the divisions, the structure was also greatly reduced. Infantry regiments contained only two active battalions, artillery battalions (105 mm) lacked one firing battery, and none of the regiments had their tank companies. The divisional tank and antiaircraft battalions had been reduced to one company/battery each. The divisions lacked any sort of division troops, such as reconnaissance, military police, replacement, medical companies, and band (see Fig. 3).

Figure 3 - Infantry Regimental Structure, 1950

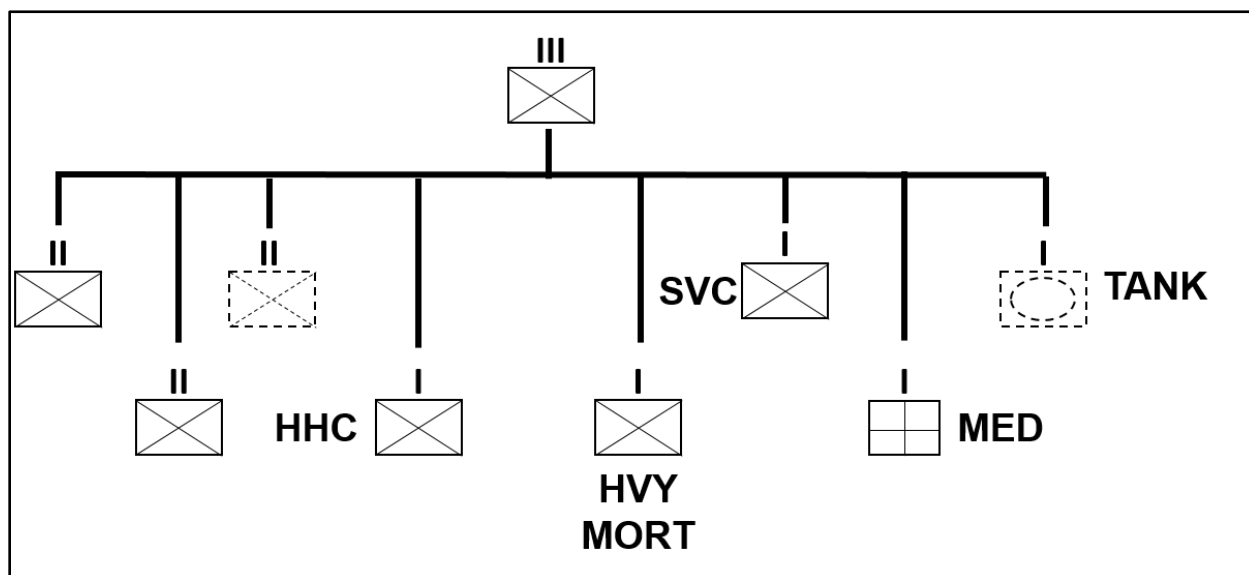

Source: Thomas E. Hanson, *Combat Ready? The Eighth U.S. Army on the Eve of the Korean War*, Williams-Ford Military History Series No. 129 (College Station: Texas A&M University Press, 2010), 91.

Congress authorized a permanent end strength of 600,000 in 1947, but postwar turbulence and the Berlin Crisis drove temporary end strength increases to 850,000 the following year. By the end of 1948, the emergency had largely passed and President Truman again cut the Army end strength to 677,000, a large number but a fraction of its peak wartime strength. The National Guard, by contrast, possessed some 29 divisions and 325,000 personnel; divisions had 100 percent of officers and 80 percent of enlisted Soldiers. The Organized Reserve in 1947 contained 185,000 personnel in 25 divisions in three tiers of readiness, including nine at full strength and nine at cadre strength and seven with officers only; the latter would not be ready until late spring 1951. The difficulties in mobilizing and training these reserve formations remained.⁵⁵

This Page Intentionally Left Blank

Training Shortfalls*

The end of World War II had brought a return to a peacetime training focus. The rapid postwar demobilization and reduced draft calls conflicted with the requirement for large numbers of occupation troops in Germany, Austria, Japan, and Korea. In an effort to get Soldiers to duty stations faster, the Army cut basic training to 8 weeks in 1948. The Army had created four "Training Divisions" to serve as training centers, but they only offered basic training. Advanced training became the unit commander's responsibility. In theory, this training philosophy prioritized the commander above all else, and rested on the assumption that no one could train troops as well as the commander. In practice, however, this training method simply shifted an undue burden to a commander who did not, in most cases, have the resources to conduct the necessary training. It also ignored the readiness component, because units with large numbers of inexperienced, undertrained Soldiers could not be combat ready. This training deficit became apparent during the Korean War, when undermanned, underequipped, and undertrained units were rushed to South Korea in response to the North Korean invasion. The 24th Infantry Division, for instance, reported only 54 percent of its pre-deployment strength as available after 17 days of continuous combat; losses included 2,400 Soldiers listed as missing.⁵⁶

Responsibility for basic training lay with the new Office of the Chief, Army Field Forces (OCAFF), which replaced the Army Ground Forces in 1948. There was no centralized training command, and basic training was conducted in training centers modeled on the Replacement Centers of World War II. After the wartime draft legislation expired in 1947, the Army's end strength dropped. The Selective Service Act of 1948 sent a new influx of inductees to the Army, however, and the OCAFF quickly realized that the 8-week course was too short for effective learning, as the transition from civilian to military mindset consumed 2-3 weeks. This did not allow time for necessary repetition and retraining, and Soldiers usually needed retraining when they got to their units. OCAFF negotiated an increase to 13 weeks in late 1948, with one more week added in February 1949. OCAFF refocused initial training with an emphasis on "physical conditioning, discipline, pride, and the development of Soldierly qualities."⁵⁷

The 1949 training schedule reflected the sharply decreased budgets in the years after World War II, as the time allowed for expensive combat training sharply decreased, while the relatively inexpensive garrison training increased. With no immediate threat of war, the post-World War II training plans reduced the amount of combat training but shifted toward a more holistic approach to training that made

* Portions excerpted from Conrad C. Crane, Michael E. Lynch, Jessica J. Sheets, and Shane P. Reilly, "Learning the Lessons of Lethality: The Army's Cycle of Basic Combat Training, 1918-2019" (Case study, Historical Services Division, U.S. Army Heritage and Education Center, U.S. Army War College, 2019).

citizens as well as Soldiers. New recruits entering the Army following World War II spent more than half of the basic training cycle on garrison and administrative tasks.⁵⁸

Of the recruits who did join the Army in the years prior to the Korean War, many were unprepared for the stresses of military life abroad. An Eighth Army junior officer described his Soldiers as “almost right off the streets . . . three to four weeks away from home, no training.” In response to this problem, the Eighth Army established a training center in Atsugi, Japan, in 1947. The need for auxiliary training centers can be attributed to the shortening of basic training to as few as eight weeks in January 1946 from thirteen weeks at the end of WWII. The Army shortened the training “in an attempt to meet the ravenous appetite for replacements in the occupied areas,” as Soldiers with combat experience sought a way home while those stationed in the Far East and Japan saw themselves as glorified tax-collectors. This paradigm changed, however, on April 15, 1949, when GEN Douglas MacArthur reoriented the philosophy of the military presence in Japan from “stern rigidity” to “friendly protective guidance” to promote economic cooperation and political accord.⁵⁹

In 1949, LTG Walton Walker took command of Eighth Army and began to return it to combat readiness. Eighth Army’s Training Directive Number Four re-focused the command’s attention on combat training. Walker ordered that training “must stress that *every soldier*, regardless of assignment, has as his primary duty the obligation to fight or support the fight.” The commander of the 25th Division Artillery noted that “rather than soft, we were weak – peacetime weak.” Walker’s training plan had been implemented, but the units had not yet reached a level of combat proficiency when the Korean War began.⁶⁰

The combination of garrison-focused basic training and shortened or curtailed advanced individual training programs sent fresh Soldiers into combat without the tactical and field training that their predecessors during World War II received. The war provided an expensive lesson in military unpreparedness. The Army’s decision to focus on garrison tasks at the expense of combat preparation, and placing the requirement for advanced training on understrength and ill-equipped combat units, resulted in disaster for units rushed to the Korean peninsula following the Communist invasion in June 1950.

Force Generation*

The rush to demobilize after World War II had denuded the Army of critical capabilities. The World War II draft ended in 1947. By 1950 only ten divisions remained, and of them only the 82nd Airborne Division had a full Modified Table of Organizational Equipment (MTOE) complement (see Fig. 4). In June of that year, the U.S. Army stood at 591,487 Soldiers, lacking 40,000 of the 630,201 authorized total. The Selective

* Portions excerpted from Conrad C. Crane, James D. Scudieri, Michael E. Lynch, and Joe Williams, “Myths of Expansibility: A Study from World War I to the Present” (Case study, Historical Services Division, U.S. Army Heritage and Education Center, U.S. Army War College, 2018).

Service Act of June 1948 had raised the ceiling from 542,000, but budgeting issues still crippled the armed forces. General of the Army Omar Bradley claimed that his failure to argue more forcefully for a greater defense budget in 1948 and 1949 (as Army Chief of Staff) “was a mistake . . . perhaps the greatest mistake I made in my postwar years in Washington.”⁶¹

The Army’s General Reserve stood at 140,000 when the Korean War began. As the Army began rushing to fill MacArthur’s requirements, the strength dropped rapidly; the General Reserve had been reduced to 90,000 only one month after the invasion. Senior military leaders were also concerned with the steady drain of troops from the General Reserve. President Truman authorized an increase of 50,000 on July 6 to 680,000, and another 60,500 a few days later to 740,500. A third increase by July 19 of 93,500 brought authorized Army end strength to 834,000. These numbers constituted a total troop strength increase of 203,000, over 32 percent, in two weeks.⁶²

Figure 4 - Regular Army Divisions, June 1950

Unit	Location
1 st Cavalry	Japan
1 st Infantry	Germany
2 nd Armored	Fort Hood, Texas
2 nd Infantry	Fort Lewis, Washington
3 rd Infantry	Fort Benning, Georgia
7 th Infantry	Japan
11 th Airborne	Fort Campbell, Kentucky
24 th Infantry	Japan
25 th Infantry	Japan
82 nd Airborne	Fort Bragg, North Carolina

The FECOM Area of Responsibility (AOR) covered 265,000 square miles and included Japan (GHQ, FECOM and Eighth US Army), the Ryukyu Islands (RYCOM), the Philippines, the Marianas-Bonin Command (MARBO), and the Volcano Islands, but not Korea. Defending Japan was the only priority in the Pacific, so forces elsewhere in the region were allowed to wither even further. By 1949, the Far East Command’s U.S. Eighth Army (EUSA) contained only 45,651 Soldiers (of whom only 26,494 were combat troops) of the 87,215 authorized, spread over five divisions. Of these, the 25th Infantry Division had two regiments with fewer than 250 Soldiers each. The Army very nearly inactivated one of GEN Douglas MacArthur’s divisions in late 1949 due to ongoing budget problems, but decided to keep it after MacArthur strenuously objected. The personnel problem continued to worsen, so by June 1950, the FECOM had dwindled to 108,500 troops. The bulk of those were assigned to four understrength divisions in

This Page Intentionally Left Blank

Japan. The 1st Cavalry Division and the 7th, 24th, and 25th Infantry Divisions were scattered throughout the Japanese home islands on occupation duty (see Fig. 5).⁶³

Figure 5 - Divisions Assigned to Occupation Duty in Japan

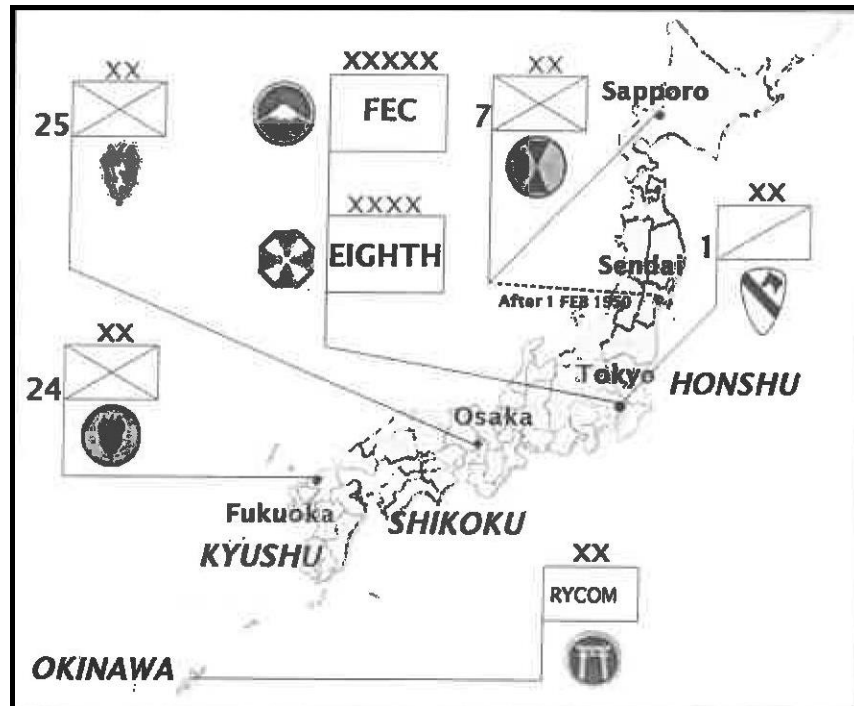

Source: Thomas E. Hanson, *Combat Ready? The Eighth US Army on the Eve of the Korean War*, Williams-Ford Military History Series No. 129 (College Station: Texas A&M University Press, 2010), 19.

President Truman authorized increases to the end strength in July 1950 to bring the Army up to 834,000, but lacked enough volunteers to fill all the slots. The Selective Service Extension Act of 1950 allowed the Army to begin involuntarily recalling inactive and volunteer reservists but the service quickly encountered problems. The Army could not determine how many of its over 416,000 individual reservists were physically qualified for duty, since periodic physicals had been suspended in 1947 due to budget cuts. Few records existed for Reserve officers, and none for enlisted Soldiers. The Army involuntarily recalled nearly 20,000 officers and 109,000 enlisted Soldiers in the first four months of the emergency, which also caused friction in the press and the public.⁶⁴

Army Chief of Staff GEN J. Lawton “Joe” Collins was reluctant to call up National Guard divisions until he had exhausted all other options. He was concerned about the economic impact and morale in the home areas of the selected divisions. He also contended that getting the units ready for combat would take too long. Nevertheless, by August the need became clear and Truman authorized the call-up of four National Guard divisions: 30th, 40th, 43rd, and 45th, plus the 196th and 278th Regimental Combat

Teams. They were to be filled with draftees to war strength by November 1, 1950, and be ready for employment by April 1, 1951.⁶⁵

Post World War II recruiting policies caused immediate problems for the National Guard call up. Army regulations prohibited anyone younger than age 17 in federal service, but the Guard had filled many slots after the war by recruiting 16 year olds. The 45th Infantry Division, for instance, discharged 23 percent of its enlisted strength in underage recruits and those under 18 who had not graduated high school. The 40th Infantry Division lost nearly 13 percent of its enlisted strength in the same way. Physical exam failures cost the divisions, on average, another 6 percent of their strength. Besides personnel, most of the units had critical shortages of equipment including radios, vehicles, and gun tubes. The units did not receive complete fill in time for training, and most units did not reach their full MTOE until they reached the port. Most therefore arrived in Korea very poorly prepared.⁶⁶

The artillery provides one crucial example of the problems the post-World War II Army faced in gearing up rapidly for war. After the Korean occupation ended, the Army inactivated the corps headquarters and associated units, which stripped EUSA of all non-divisional artillery. This supporting artillery was critical to the Army's doctrine, made more so by heavy artillery losses early in the war and the relatively weak infantry forces available. Republic of Korea (ROK) divisions also had very little artillery, so the EUSA needed to support the ROK units as well. MacArthur requested twenty-five field artillery battalions for EUSA in July 1950. The General Reserve had only seven such battalions available, but sent four of these, plus some lighter weapons, to Korea immediately. In order to get these units up to war strength, however, the Army had to strip most of the other artillery units in the General Reserve.⁶⁷

The National Guard mobilized eleven artillery battalions for Korea:

- 155 mm self-propelled (2)
- 155 mm towed (3)
- 105 mm self-propelled (5)
- Observation (1)

Like all Army units in 1950, these units had varied proficiency and degree of readiness, shortages of equipment, personnel turbulence among junior enlisted Soldiers, and a small core of technically qualified personnel supporting a larger number of personnel with little experience or training.⁶⁸

Part of the reluctance to mobilize Guard units came from the fear of stripping the General Reserve of capabilities in case Korea turned into World War III. In addition to the divisions and Echelons Above Division (EAD) artillery units, the Army mobilized many non-divisional units, including anti-aircraft artillery (AAA) and support units, to replace the EAD infrastructure that had been cut out of EUSA. During the conflict, the Army called up a total of six National Guard divisions, and ninety-eight battalions of

various types, in addition to numerous other smaller units and headquarters. Most went to General Reserve (see Fig. 6).⁶⁹

Figure 6 - National Guard Units Activated during the Korean War

Units	Far East	Europe	General Reserve	Total
Divisions	2	2	2	6
FA Battalions	10	4	12	26
FA Observation Battalions	1	0	4	4
MP Battalions	0	1	4	5
Engineer Battalions	6	2	8	16
Tank Battalions	0	2	2	4
AAA Gun Battalions	3	0	40	43

Source: Adapted from William M. Donnelly, *Under Army Orders: The Army National Guard during the Korean War* (College Station: Texas A&M University Press, 2001), Appendix A.

As units received notification for deployment, they began requesting immediate personnel fills. Since these were urgent requirements, the Army filled the openings based on rank without regard to Military Occupational Specialty (MOS). The 300th Armored Field Artillery Battalion, a National Guard unit alerted for Korea, provides an example. The unit arrived at Fort Lewis in September 1950, received its required fillers, and began training. The post Adjutant General, however, began stripping the 300th to fill shortages in other units deploying earlier, including non-artillery units. The battalion lost 40 percent of its enlisted strength before the post staff began replacing them with anyone available on post. These Soldiers, stripped from other units at Fort Lewis, included musicians, firefighters, and Soldiers straight from basic training. Despite this glaring MOS-mismatch, and over the battalion commander's objections, the battalion deployed as scheduled.

To operate training centers, the Army activated six more Regular divisions in 1950, including one to replace a division deploying to Europe. Four more National Guard divisions were federalized in late 1950 after the Chinese entered the war in October, but they served primarily as replacement and training units. One more Regular division was activated in 1951, the 1st Armored, but it went to Germany. Ultimately, ten Regular divisions were also used as training centers. Eight Army divisions went to the Far East, Japan and Korea, including the National Guard's 40th and 45th Infantry Divisions. The two Army National Guard divisions deployed to Japan in April 1951, after some seven months CONUS training, and committed to Korea only after additional training in late 1951.

Despite the war in Korea, Russia remained the main strategic threat and the nation committed more ground forces to NATO. The Army deployed the 4th Infantry Division, 2nd Armored Division, and the National Guard's 28th and 43rd Infantry Divisions to Germany from May to November 1951 to augment 1st Infantry Division and the Military Constabulary. The Army Reserve contributed over 244,000 personnel, but no divisions.⁷⁰

The readiness of operational Army HQ was a problem rivaling that of trained combat troops. The Army needed to institute major changes in response to the strident calls from MacArthur to overcome deep-seated unpreparedness to deploy two corps HQ and enablers for the initial intervention in Korea in 1950. In three years the Army added one Theater Army, one Field Army, and seven Corps headquarters.⁷¹

Force Deployment*

Three of the units that deployed to Korea in September and October 1950 illustrate the difficulties that the new Department of Defense, and especially the ground forces, experienced in deploying to a "come as you are" war. The 7th Infantry Division and the 1st Marine Division landed at Inchon on September 15, 1950, while the 3rd Infantry Division landed at Wonsan on the East Coast in October 1950.

7th Infantry Division

Beset by a grave manpower shortage, MacArthur appealed to the Korean government for augmentation by Korean citizens. The government readily agreed, and by mid-August, thousands of recruits began arriving at EUSA to help fill holes in the line. Some of those recruits, called Korean Augmentees to U.S. Army (KATUSAs), went to Japan to join the 7th Infantry Division, which had been stripped to fill other divisions deploying to Korea in July and August. The division received more than 8,600 KATUSAs before it embarked for Inchon, bringing its total strength up to 24,845. The KATUSA program was only moderately successful. The ROK government conscripted Soldiers right off the street and sent them to the U.S. Army with no military training at all. EUSA units formed KATUSAs and their buddies into separate platoons with American officers and NCOs. The lack of military training and the language barrier prevented the experiment from being successful, and the units dropped the buddy system as new American replacements arrived throughout the fall and winter. American officers and NCOs then organized the KATUSAs into squads and platoons with American leaders, and used them for security, limited patrolling, and labor details. The KATUSAs were more effective under these circumstances. The 7th Infantry Division integrated them throughout the command at the ratio of 100 per company or battery, and paired each KATUSA with a U.S. Soldier in a "buddy" system.⁷²

* Portions excerpted from Michael E. Lynch, *Edward M. Almond and the U.S. Army: From the 92nd Infantry Division to the X Corps* (Lexington, KY: University Press of Kentucky, Publication Forthcoming). Used by permission.

1st Marine Division

The Joint Chiefs granted MacArthur's request for a Marine division and alerted the 1st Marine Division at Camp Pendleton, California. The 1st Marine Division organization mirrored that of an Army division, with three infantry regiments and support units. Despite having a similar structure to Army divisions, with three infantry regiments and supporting artillery, the Marine Division was larger but less mobile. Marine regiments were larger than infantry regiments. The division included a Marine air wing that Army divisions did not have, and it lacked the ground transportation necessary to move. The 1st Marine Provisional Brigade deployed into Pusan on August 3. The brigade included the only active regiments of the 1st Marine Division, which included the 5th Marine Regiment (Infantry), 11th Marine Regiment (Artillery), and Marine Aircraft Group (MAG)-33.

The 1st Marine Regiment (commanded by the already legendary Col Lewis B. "Chesty" Puller) and the 7th Marine Regiment had both activated on August 7, 1950, and were still forming at Camp Pendleton. In the years after World War II, the Marine Corps had experienced the same budget pressures as the other services, but the push to reduce force structure had fallen particularly hard on the smallest service. In order to fill out the remaining two regiments, the Commandant of the Marine Corps directed the 2nd Marine Division at Camp Lejeune, North Carolina, be stripped to fill all available spaces in the 1st Marine Division. The Commandant had also recalled individual Marine reservists and reserve units, some of whom had already deployed with the provisional brigade. Security force units around the country were authorized to reduce to 50 percent manning in order to provide Marines to deploy. Finally, the 3rd Battalion, 6th Marines, currently deployed in the Mediterranean, was ordered to move directly to Korea, and re-flagged as 3rd Battalion, 7th Marines.⁷³

3rd ID/65th Regimental Combat Team

The lack of readiness of understrength, over-tasked active component units became clear with the planned deployment of the 3rd Infantry Division in September 1950. The division contained only half its authorized troops. The only alternative was the 82nd Airborne Division at 85 percent strength. In order to reach combat strength, the division cannibalized one of its infantry regiments to fill the other two. The 65th Infantry Regiment from Puerto Rico joined the 3rd Infantry Division as its third regiment after arrival in Korea. The 65th Infantry was a Regular Army Regiment based in Puerto Rico. Under the custom of the time, most of the unit's officers were "continentals," while some of the junior officers and all the NCOs and enlisted Soldiers were Puerto Rican. This unique unit was not immune to the ravages of the postwar drawdown either, and in August 1950 could muster only 92 officers and 1,895 enlisted of the 4,000 authorized. Only two of the three authorized battalions were active. The Army ordered 3rd Battalion, 33rd Infantry, also consisting largely of Puerto Rican Soldiers, at Fort Kobbe, Panama Canal Zone, to provide the 65th Infantry's third battalion. To accelerate the deployment, 65th Infantry Regiment moved directly to Korea, picking up 3rd Battalion, 33rd Infantry as it passed through the Panama Canal Zone, and arrived before the rest of the division.

The regiment lacked a tank company, so the Army deployed a tank company from Fort Meade, Maryland, to arrive separately. Unique among the regiments deploying to Korea, the 65th deployed with its full complement of officers and Soldiers, with a 10 percent overage.⁷⁴

Conclusion

Task Force Smith has become a metaphor for lack of Army readiness, but the issues at the beginning of the Korean War extended well beyond the troubles of one infantry battalion. The U.S. also faced interrelated and complex issues when addressing national preparedness and military readiness. The nation's strategic priorities, the economy, political pressures, and parochial competition between services combined to produce the unreadiness at the beginning of the Korean War.

The modern observer may gain insights from other historical examples, but the Korean War is particularly relevant. The myriad issues that affect readiness are constants, but the characteristics of each are variable. In the five years between the end of World War II and the beginning of the Korean War, the military saw numerous changes to Doctrine, Organization, Training, Materiel, Leadership, Personnel, Facilities and Policy (DOTLMPF-P). Identifying and evaluating those changes is valuable for understanding the nation's preparedness and readiness challenges.

In George Washington's farewell address, he warned of the danger of "entangling alliances," and that warning had guided U.S. foreign policy for most of the next two centuries. The world wars, however, changed that notion. After World War II, the Truman Administration struggled with preparedness in a world being defined by the outcome of that war. The nation was slowly understanding its role as leader of the "free world," while that term itself was being defined. With a national culture that rejected militarism but embraced patriotism, the notion of becoming what later came to be called a "superpower" came slowly. As the U.S. relationship with USSR deteriorated, the identification of potential enemies drove policy and strategic priorities. The concept of collective defense (with its necessary "entangling alliances") became not only a defense method, but a foreign policy.

Domestic priorities define force readiness at least as much as foreign policy. Decrying a Congress and administration determined to cut military budgets is a timeless activity for military leaders, yet the economic challenges for the nation at the end of World War II were significant. It was all so easy, in the wake of a great victory, for those outside the military to assume the military was invincible, and fully equipped for any future challenge. The military machine built for World War II was the largest in the nation's history, and the vast sums of money spent and tremendous amount of armament purchased must surely be enough. The nation also comforted itself with the traditional assumption that the last war would be the last one.

Army and Navy leaders might bemoan the emphasis on the Air Force in a newly nuclear world, but it would not be the last time that the introduction of new technology yielded cost savings in terms of personnel cuts. Army leaders also would do well to remember that while end strengths maybe externally imposed, uniformed leaders make decisions about necessary force structure.

The United States possesses tremendous resources of every kind, but not always all of those necessary for war. Studying the resourcing issues of the Korean War era gives insight to modern challenges. The government faced unlikely challenges in quickly building a war machine: a booming economy and low unemployment. These domestic issues benefitted the country as a whole, yet the obstacles they presented to shifting to a war footing were obvious.

The Army frequently uses the term Lessons Learned, yet not all lessons are learned. This case study does not provide a cookbook for the next “come as you are war,” but it does provide valuable insights for the modern military leader. The United States should not plan for the last Korean War, but it should look to that war for useful and timely parallels. Only after the next war can the nation and its military determine if it learned the lessons of the last one.

¹ Schnabel, *History of the Joint Chiefs of Staff*, vol.I, 61-62.

² Miller, *Plain-Speaking*, 164.

³ Reeder, “Korean Ammunition Shortage,” 9.

⁴ National Security Act of 1947, Pub. L. 80-253, 61 Stat. 495 (1947); Gole and others, *The Department of Defense*, 35; Edward M. Almond to J. Lawton Collins, August 21, 1947; J. Lawton Collins to Edward M. Almond, September 10, 1947; and Edward M. Almond to J. Lawton Collins, October 1, 1947; all Box 54B, Edward M. Almond Papers, U.S. Army Heritage and Education Center, Carlisle, PA (hereafter Almond Papers). During World War II, the heads of the services -- GEN George C. Marshall, Chief of Staff, Army; ADM Ernest J. King, Chief of Naval Operations; and GEN Henry “Hap” Arnold, Chief of the Army Air Corps worked with ADM William Leahy, Chief of Staff to Commander in Chief, as a de-facto Joint Chiefs of Staff. The Commandant of the Marine Corps became a full member of the Joint Chiefs of Staff in 1979. The Act also created the Central Intelligence Agency (CIA). NSA 1947 directed the Army to provide logistical support to the Air Force for the first two years, which some feared would become a permanent mission. GEN J. Lawton “Lightning Joe” Collins, Army Deputy Chief of Staff, warned that the Army would not be “solely a service installation for the Air Force.”

⁵ Condit, *History of the Joint Chiefs of Staff*, vol. II, 3; Wolk, “Revolt of the Admirals,” 62-67; Hewes, *From Root to McNamara*, 271.

⁶ Boose, *Over the Beach*, 70-72; Executive Order No. 9950, Revoking Executive Order No. 9877 of July 26, 1947, Prescribing the Functions of the Armed Forces, 13 FR 2191.

⁷ Statement of GEN Omar N. Bradley, Chairman, Joint Chiefs of Staff, before the Armed Services Committee of the House of Representatives, October 1949, 24. Bradley was promoted to General of the Army on September 22, 1950.

⁸ Petty, “Industrial Mobilization Planning,” 34-35.

⁹ Pierpaoli, “The Price of Peace,” 3, 27; Reeder, “Korean Ammunition Shortage,” 9.

¹⁰ Condit, *History of the Joint Chiefs of Staff*, vol. II, 156.

¹¹ Condit, *History of the Joint Chiefs of Staff*, vol. II, 153-156.

¹² Condit, *History of the Joint Chiefs of Staff*, vol. II, 159.

¹³ Condit, *History of the Joint Chiefs of Staff*, vol. II, 161.

¹⁴ Condit, *History of the Joint Chiefs of Staff*, vol. II, 163.

¹⁵ Condit, *History of the Joint Chiefs of Staff*, vol. II, 165-166.

¹⁶ Condit, *History of the Joint Chiefs of Staff*, vol. II, 195.

¹⁷ Condit, *History of the Joint Chiefs of Staff*, vol. II, 203.

¹⁸ General Headquarters, Southwest Pacific Area [sic], General Order No. 1, February 19, 1949, Subject: Announcement of Staff, Box 56, Almond Papers; Cole and others, *The History of the Unified Command Plan*, 11-14. MacArthur's staff used the acronym "FECOM," but the Joint Staff in Washington used "FEC." Contemporary sources use both acronyms. I have used FECOM throughout for clarity. Schnabel, *Policy and Direction*, 48-49, n20.

¹⁹ Condit, *History of the Joint Chiefs of Staff*, vol. II, 248-249.

²⁰ Condit, *History of the Joint Chiefs of Staff*, vol. II, 250, 255.

²¹ Condit, *History of the Joint Chiefs of Staff*, vol. II, 261.

²² ExecSecy to NSC, memorandum, "The Positions of the United States with Respect to Asia," December 30, 1949, quoted in Condit, *History of the Joint Chiefs of Staff*, vol. II, 262. The ECA was established to administer the Marshall Plan,

²³ Quoted in James F. Schnabel, *Policy and Direction*, 50.

²⁴ Millett, *The War for Korea, 1945-1950*; Lee, "The United States and the Formation of the Republic of Korea Army, 1945-1950," 138-50.

²⁵ Pierpaoli, "The Price of Peace," 33-36.

²⁶ Pierpaoli, "The Price of Peace," 3.

²⁷ Petty, "Industrial Mobilization Planning," 33; Reeder, "Korean Ammunition Shortage," 12-13; Kreidberg and Henry, *History of Military Mobilization*, 541.

²⁸ Reeder, "Korean Ammunition Shortage," II-4.

²⁹ Office of Defense Mobilization, *Report to the President: Building America's Might*, April 1951, 3.

³⁰ Office of Defense Mobilization, *Building America's Might*, 7. The federal fiscal year in 1951 (and until 1976) ran 1 July-30 June. Inflation conversions made using "The Inflation Calculator" at <https://westegg.com/inflation/infl.cgi>, which uses Consumer Price Index statistics from *Historical Statistics of the United States* (USGPO, 1975) and the annual *Statistical Abstracts of the United States*.

³¹ NSA 1947; Petty, "Industrial Mobilization Planning," 35.

³² NSA 1947; Petty, "Industrial Mobilization Planning," 35. The MB and NSRB were both abolished in 1953. MB functions transferred to the SECDEF, while NSRB functions moved to the Office of Defense Mobilization.

³³ Petty, "Industrial Mobilization Planning," 35-36; Office of Defense Mobilization, *Meeting Defense Goals*, 1. Many of the functions of the NSRB were absorbed by the Office of Defense Mobilization in December 1950 which served an execution as well as a planning function.

³⁴ Office of Defense Mobilization, *Building America's Might*, 13, 39-40.

³⁵ Petty, "Industrial Mobilization Planning," 125.

³⁶ Office of Defense Mobilization, *Building America's Might*, 15-16.

³⁷ Office of Defense Mobilization, *Building America's Might*, 13, 19.

³⁸ Office of Defense Mobilization, *Building America's Might*, 11-15, 18.

³⁹ Reeder, "Korean Ammunition Shortage," 12-13.

⁴⁰ Office of Defense Mobilization, *Meeting Defense Goals*, 7, 18.

⁴¹ Office of Defense Mobilization, *Meeting Defense Goals*, 8; *Building America's Might*, 11.

⁴² Office of Defense Mobilization, *Building America's Might*, 1-3, 9.

⁴³ Connor, "The Armor Debacle in Korea, 1950," 67-76; Reeder, "Korean Ammunition Shortage," 49; Office of Defense Mobilization, *Building America's Might*, 8.

⁴⁴ Office of Defense Mobilization, *Building America's Might*, 9,14

⁴⁵ Reeder, "Korean Ammunition Shortage," 10-11.

⁴⁶ Office of Defense Mobilization, *Building America's Might*, 36-39.

⁴⁷ Reeder, "Korean Ammunition Shortage," 2.

⁴⁸ Reeder, "Korean Ammunition Shortage,"5.

⁴⁹ Reeder, "Korean Ammunition Shortage," 3-4.

⁵⁰ Reeder, "Korean Ammunition Shortage," 1-4; Giangreco, *Artillery in Korea*, 13-15, 20-21 endnotes passim.

⁵¹ Hermes, *Truce Tent and Fighting Front*, 224-29.

⁵² Petty, "Industrial Mobilization Planning," 120-121; Reeder, "Korean Ammunition Shortage," 6-8.

⁵³ Reeder, "Korean Ammunition Shortage," 4, 71.

⁵⁴ Weigley, *History of the U.S. Army*, 506-509; Sparrow, *History of Personnel*, 64-75, 243, 326-327.

⁵⁵ Hanson, *Combat Ready?*, 23; Wilson, *Maneuver and Firepower*, Table 17, 209-10, 215, 239-47; Thompson, "Army Downsizing," 28; Weigley, *History of the U.S. Army*, 506-209.

⁵⁶ Hanson, *Combat Ready?*, 30; Appleman, *South to the Naktong*, 59, 179-80. See also Daugherty, "'Unpreparing for War,'" (unpublished MS, 2015), 5 (pages unnumbered) and Wilson, 243-245.

⁵⁷ Daugherty, 9-10 (pages unnumbered); Department of the Army, Army Training Program 21-1, *Basic Military Training Program (14 weeks) for Newly Enlisted Men*, 1949, 1. OCAFF was a Field Operating Agency rather than a command.

⁵⁸ Department of the Army, Army Training Program 21-1, 1949, 4.

⁵⁹ Hansen, *Combat Ready?*, 25.

⁶⁰ Wilson, *Maneuver and Firepower*, 239; Hanson, *Combat Ready?*, 18-22.

⁶¹ Hanson, *Combat Ready?*, 21; Wilson, "Facilities for Mobilization in the Twentieth Century," 7, 13, 23.

⁶² Schnabel, *Policy and Direction*, 118-119.

⁶³ Schnabel, *Policy and Direction*, 50-53.

⁶⁴ Schnabel, *Policy and Direction*, 120-122.

⁶⁵ Schnabel, *Policy and Direction*, 123.

⁶⁶ Donnelly, *Under Army Orders*, 34, 124.

⁶⁷ Donnelly, *Under Army Orders*, 72-76.

⁶⁸ Donnelly, *Under Army Orders*, 121-122.

⁶⁹ Donnelly, *Under Army Orders*, 23, Appendix A.

⁷⁰ Weigley, *History of the U.S. Army*, 508-209; Wilson, *Maneuver and Firepower*, 239-247.

⁷¹ Schnabel, *Policy and Direction*, 134-136.

⁷² Appleman, *South to the Naktong*, 386-389, 491-492.

⁷³ Marine Corps Board Study, "An Evaluation of the Influence of Marine Corps Forces on the Course of the Korean War (4 AUG 50 – 15 DEC 50)," vol. 1 of 2, August 4, 1952, Korean War Collection, Box 1, Archives Branch, Marine Corps History Division, Marine Corps Base, Quantico, Virginia; Ernest H. Giusti, "The Mobilization of the Marine Corps Reserve in the Korean Conflict" (Headquarters, Marine Corps: Historical Section, G3, 1953).

⁷⁴ Donnelly, *Under Army Orders*, 131-133; Appleman, *Escaping the Trap*, 3-4; Almond MHI MHI Interview, Part IV, 61-62; Villahermosa, *Honor and Fidelity*, 17-25. The 65th Infantry Regiment was inactivated as a Regular Army unit in 1959, and subsequently reactivated in the Puerto Rico National Guard.



U.S. Army Heritage and Education Center
U.S. Army War College
950 Soldiers Drive
Carlisle, PA 17013

<http://ahec.armywarcollege.edu>