

# MARINE SAFETY: DOMESTIC INSPECTION PROGRAMS



**COMDTINST 16000.71**  
**September 2021**

U.S. Department of  
Homeland Security

United States  
Coast Guard



Commandant  
United States Coast Guard

US Coast Guard Stop 7501  
2703 Martin Luther King Jr. Ave SE  
Washington, DC 20593-7501  
Staff Symbol: CG-CVC  
Email: CG-CVC@uscg.mil

COMDTCHANGENOTE 16000  
20 SEP 2021

COMMANDANT CHANGE NOTICE 16000

Subj: CH-3 TO MARINE SAFETY MANUAL VOLUME II, COMDTINST M16000.7B

1. PURPOSE. This Commandant Change Notice publishes the cancellation of Marine Safety Manual Volume II, COMDTINST M16000.7B, and replacement with separate Commandant Instructions, one for each chapter of the existing Manual.
2. ACTION. All Coast Guard unit commanders, commanding officers, officers-in-charge, deputy/assistant commandants, and chiefs of headquarters staff elements shall comply with the provisions of this Commandant Change Notice. Internet release is authorized.
3. DIRECTIVES AFFECTED. With the addition of this Commandant Change Notice, Marine Safety Manual Volume II, COMDTINST M16000.7B, is cancelled.
4. DISCUSSION. The content of Marine Safety Manual remains intact. The primary reason for this change is to allow for timely revision and re-publication of the individual Commandant Instructions.
5. DISCLAIMER. This guidance is not a substitute for applicable legal requirements, nor is it itself a rule. It is intended to provide operational guidance for Coast Guard personnel and is not intended to nor does it impose legally-binding requirements on any party outside the Coast Guard.
6. MAJOR CHANGES. Sections A through G of Marine Safety Manual Volume II, COMDTINST M16000.7B, are now individual and independent Commandant Instructions. They are listed below.
  - a. Marine Safety: Marine Inspection Administration, COMDTINST 16000.70 (pages A1-1 - A7-43)

DISTRIBUTION - SDL No. 170

	a	b	c	d	e	f	g	h	i	j	k	l	m	n	o	p	q	r	s	t	u	v	w	x	y	z	
A																											
B		X			X									X			X										
C											X																
D	X	X	X	X							X																
E														X													
F			X							X																	
G																											
H																											

NON-STANDARD DISTRIBUTION:

- b. Marine Safety: Domestic Inspection Programs, COMDTINST 16000.71 (pages B1-1 – B10-3)
- c. Marine Safety: Inspection of Engineering Systems, Equipment, and Materials, COMDTINST 16000.72 (pages C1-1 – C5-31)
- d. Marine Safety: Port State Control, COMDTINST 16000.73 (pages D1-1 – D7-38)
- e. Marine Safety: International Conventions, Treaties, Standards, and Regulations, COMDTINST 16000.74 (pages E1-1 – E4-3)
- f. Marine Safety: Carriage of Hazardous Materials, COMDTINST 16000.75 (pages F1-1 – F5-35)
- g. Marine Safety: Outer Continental Shelf Activities, COMDTINST 16000.76 (pages G1-1 – G6-24)

7. ENVIRONMENTAL ASPECT AND IMPACT CONSIDERATIONS.

- a. Commandant CG-47 reviewed the development of this Instruction, and the general policies contained within it, and determined that this policy falls under the Department of Homeland Security (DHS) categorical exclusion A3. No further environmental analysis is necessary in accordance with the U.S. Coast Guard Environmental Planning Policy, COMDTINST 5090.1 (series).
- b. This Instruction will not result in any substantial change to existing environmental conditions or violation of any applicable federal, state, or local laws relating to the protection of the environment. It is the responsibility of the action proponent to evaluate all future specific actions resulting from this policy for compliance with the National Environmental Policy Act (NEPA), other applicable environmental mandates, and the U.S. Coast Guard Environmental Planning Policy, COMDTINST 5090.1(series).

8. DISTRIBUTION. No paper distribution will be made of this Commandant Change Notice. An electronic version will be located on the following Commandant (CG-612) web sites. Internet: <http://www.uscg.mil/directives/>, and CGPortal: <https://cg.portal.uscg.mil/library/directives/SitePages/directives.aspx>

9. PROCEDURE. Cancel Marine Safety Manual Volume II, COMDTINST M16000.7B and replace with COMDTINSTs 16000.70 thru 16000.76.

10. RECORDS MANAGEMENT CONSIDERATIONS. Records created as a result of this Instruction, regardless of format or media, must be managed in accordance with the records retention schedules located on the Records Resource Center CGPortal site: <https://cg.portal.uscg.mil/units/cg61/CG611/SitePages/Home.aspx>.

11. FORMS/REPORTS. The forms called for in this Commandant Change Notice are available in USCG Electronic Forms on the Standard Workstation or on the Internet: <https://www.dcms.uscg.mil/forms/>; CGPortal at <https://cgportal.uscg.mil/library/forms/SitePages/Forms.aspx>; and Intranet at <https://www.dcms.uscg.mil/forms/>.

12. REQUEST FOR CHANGES. Request for changes to the previous mentioned Commandant Instructions may be sent to Commandant (CG-CVC) at [HQS-SMB-COMDT-CG-CVC@uscg.mil](mailto:HQS-SMB-COMDT-CG-CVC@uscg.mil).

/J. W. MAUGER/  
Rear Admiral, U. S. Coast Guard  
Assistant Commandant for Prevention Policy

**SECTION B: DOMESTIC INSPECTION PROGRAMS****CHAPTER 1: INSPECTION OF VESSELS FOR CERTIFICATION****A. INTRODUCTION**

This chapter of the Marine Safety Manual (MSM) provides guidance regarding inspections for the issuance of a Certificate of Inspection (COI), as well as information concerning various decisions and interpretations of regulations. This guidance is supplemented by references to other sections of the MSM, which have additional information. The responsibilities of the Officer in Charge, Marine Inspection (OCMI) and inspection personnel are discussed in the MSM, Volume I, Administration and Management, COMDTINST M16000.6 (series).

---

**B. CERTIFICATION OF VESSELS**

---

**1. General Provisions**

46 U.S.C. Chapter 33 requires that certain vessels possess a COI. The issuance of a COI depends on the vessel's satisfactory completion of an inspection for certification. A vessel's retention of the COI depends on the continued maintenance of the vessel in a safe operating condition. When satisfied that the vessel in question complies with all applicable statutes and regulations and can be operated safely without endangering life or property, the OCMI is authorized to issue a Permanent COI or a Temporary COI, Form CG-854, pending issuance of the permanent COI. Both permanent and temporary COIs are generated by the Marine Information for Safety and Law Enforcement (MISLE) database.

**NOTE:** The initial COI may be completed before issuance of the Certification of Document (COD). The COI should be issued, provided the National Vessel Documentation Center (NVCD) has received the application for documentation.

Contact the NVCD about vessel documentation questions.

- a. Government owned vessels. Government owned vessels may be subject to maritime and environmental safety laws. To determine if a regulation applies to government vessels, one should check the applicability sections of the applicable CFR subchapter.

**SECTION B: DOMESTIC INSPECTION PROGRAMS****CHAPTER 1: INSPECTION OF VESSELS FOR CERTIFICATION**

- b. Jones Act requirements for coastwise U.S. trade. Vessels engaged in coastwise or Great Lakes trade must be U.S.-built vessels. For a vessel to be considered a U.S.-built vessel, it must have been constructed totally within the United States. This includes fabricated structural vessel components; there is no allowance for fabrication of even a small portion of major components outside of the United States.

**NOTE:** Construction materials that are otherwise processed per detailed instructions so as to permit simplified assembly with nominal preparation will normally be considered fabricated.

---

**2. Periods of Validity**

- a. Introduction. The periods of validity for a COI vary by vessel type and are specified within the applicable regulations. In general, they are as follows:
- (1) 1 year for passenger vessels on all routes, small passenger vessels that engage on international voyages, Nautical School Ships, and nuclear powered vessels.
  - (2) 5 years for cargo, tank, oceanographic research, small passenger vessels engaged exclusively on domestic voyages, and miscellaneous vessels.
- b. COIs are normally issued for the maximum period specified in the applicable regulations. A vessel is certificated on its ability to meet the minimum safety standards set forth in the regulations. Under existing law, any vessel that meets these standards is entitled to a full-term COI.
- c. A vessel that is unable to meet the minimum standards must correct its deficiencies prior to certification or, if the deficiencies are minor and do not make operation of the vessel unsafe, be granted reasonable time in which to make the necessary corrections.
- d. An owner may surrender the COI and apply for inspection for recertification at any time prior to the expiration date.
- e. The conditions under which certain vessels on foreign voyages may return to the United States with expired certificates are discussed in Paragraph C.7 of this chapter.
- f. Vessels with expired COIs. A vessel with a COI that has lapsed, regardless of circumstances or reasons, may be required to undergo inspection for certification as a new vessel if the owner/operator desires to place the vessel back into certificated service.

## SECTION B: DOMESTIC INSPECTION PROGRAMS

**CHAPTER 1: INSPECTION OF VESSELS FOR CERTIFICATION**

- (1) The cognizant OCMI will make a determination as to the type and extent of inspection requirements appropriate after giving due consideration to the circumstances behind the vessel's out-of-service period.
  - (2) When making this the determination, the OCMI must closely evaluate environmental conditions such as operations in fresh water, salt water, or drydock lay-up as well as any structural modifications made to the vessel.
- g. Grandfathering. The OCMI may, at his or her discretion, require a formerly certificated vessel to be inspected as a new vessel regardless of its former status as a certificated vessel. Such vessels would no longer be afforded exemption from regulatory requirements under grandfather provisions provided by law, regulation, or policy.
- h. A vessel that was once certificated does not qualify indefinitely as an "existing" vessel, especially when it has been structurally modified and/or out of service for an extended period. A vessel whose COI has lapsed will be required to meet those inspection for certification requirements determined to be appropriate by the issuing authority—the OCMI.
- i. 1-year certificates. Regulations permit the issuance of certificates to certain cargo, tank, and miscellaneous vessels for periods of less than 2 years. Examples are 1-year certificates for--
- (1) Vessels equipped with firetube main propulsion boilers, including riveted lap seam boilers;
  - (2) Vessels that, in the OCMI's opinion, should be inspected on a 1-year basis by reason of route (the Commandant's approval must be obtained in these cases); and
  - (3) Nuclear powered vessels.

---

**3. Entries on COIs**

- a. Number of passengers stated. Except for ferryboats, the OCMI is responsible for determining the number of passengers that a vessel has accommodations for and can carry with prudence and safety, as provided for in 46 U.S.C. 3501. That number must be stated on the COI. The OCMI must not permit the number of passengers allowed to exceed that permitted by law or regulation, or specified in the vessel's stability letter.
- b. Maximum number of passengers on ferry vessels. See 46 U.S.C. 3501 Notes of Decisions, for guidance on how to compute and list the number of passengers and crew on the COI for ferry vessels. 46 U.S.C. 3501 notes that "...respecting the number of passengers that may lawfully be carried by a passenger steamer,

**SECTION B: DOMESTIC INSPECTION PROGRAMS****CHAPTER 1: INSPECTION OF VESSELS FOR CERTIFICATION**

[46 U.S.C. 3502] have no application to a ferryboat, though temporarily employed as an excursion boat.”

- (1) Essentially, 46 U.S.C. 3501 considers ferry vessels to be cargo vessels, not passenger vessels. Accordingly, the number of passengers and crew authorized on a ferry vessel is not required to be listed on the COI.
  - (2) However, many ferry vessels are a combination of both cargo and passenger vessels. As such, when the OCMI and the owner of a ferry vessel agree on the number of passengers that can be carried safely, and when the owner of the ferry desires it, the maximum number of passengers permitted may be entered on the COI.
- c. Tankships carrying grain cargo. No COI amendment is necessary for a tankship to carry grain cargo. The Federal Grain Inspection Service provides inspectors to oversee loading of vessels with grain.

**NOTE:** When stability is a factor in limiting the maximum number of persons that can be carried with safety on any ferry vessel, the total number of persons permitted aboard must be stated in the stability letter.

---

#### **4. Temporary COIs**

A Temporary COI, Form CG-854, provides evidence of the satisfactory completion of an inspection for certification (see 46 U.S.C. 3309). It stands in lieu of a COI and, until replaced by a COI, has all the force and effect of the permanent certificate. The temporary certificate is intended for use when the immediate issuance of a COI is not possible at the completion of an inspection. It is not the Commandant's intention that a COI should be withheld pending correction of minor deficiencies after a temporary certificate has been issued. Further, when the permanent COI can be issued in time to meet the vessel's needs, a temporary certificate should not be issued.

---



## SECTION B: DOMESTIC INSPECTION PROGRAMS

## CHAPTER 1: INSPECTION OF VESSELS FOR CERTIFICATION

**5. Seasonal Restrictions**

Seasonal limitations are intended to ensure the overall seaworthiness of the vessel and the safety of the passengers carried under differing operational conditions, without completely halting the operation of the vessel during any specific period of time. COI statements of seasonal restrictions must be as descriptive as possible, showing limitations on vessel routes, the scope of passengers carrying authorizations, and the like.

---

**6. Certificates Expiring at Sea**

- a. COI extensions. There are no statutory provisions that allow for the extension of a COI. Accordingly, requests for extensions of certificates must be denied.
  - b. Expirations of COIs during foreign voyages. Under 46 U.S.C. 3314, a vessel may complete a foreign voyage to a port of the United States within 30 days of the expiration of its COI without incurring penalties for operating without a valid certificate.
    - (1) The vessel owner/operator must apply for an inspection for certification at the first U.S. port of call.
    - (2) The vessel must then complete an inspection for certification, and a new COI or a Permit to Proceed will be issued, if an inspection for certification has been conducted to the point that the OCMI considers the vessel safe to proceed on the voyage. (See MSM Volume II, Material Inspection, COMDTINST M16000.7 (series), Chapter A6 for more details.)
  - c. Vessels sailing less than 15 days prior to expiration of COI. 46 U.S.C. 3314 prevents the grace period described above from being applied if the COI would expire within 15 days of the date of sailing from a U.S. port. A vessel would not violate this provision merely by sailing to a foreign port within 15 days of the expiration of the COI, provided it returns to a U.S. port before the COI expires. Such a vessel would be in violation if it sailed within 15 days of the expiration date and failed to return before expiration of the COI.
- 

**7. Marking of Hailing Ports**

Under 46 CFR 67.123, a hailing port must be marked on some clearly visible exterior part of the stern of a documented vessel. The markings must be durable and made in clearly legible letters of the Latin alphabet or Arabic or Roman numerals of no less than 4 inches in height.

---

## SECTION B: DOMESTIC INSPECTION PROGRAMS

## CHAPTER 1: INSPECTION OF VESSELS FOR CERTIFICATION

**8. Towing of Vessels Permanently Laid-Up, Dismantled, or Out-of-Commission**

a. Vessels are frequently towed for purposes of permanent removal from navigation or scrapping as these vessels reach the end of their useful lives. It has been generally determined that such vessels making a one-way voyage under tow; without crew, cargo, or passengers; and not holding documents as a merchant vessel, are not subject to inspection and certification requirements. Such vessels are "laid up, dismantled, or out of commission" under 46 U.S.C. 3302(e) and 46 CFR 90.05-1(a)(3). In accordance with this determination, when the OCMI is satisfied by documentary evidence or other means that certain conditions are met, such vessels do not require a COI. These conditions may include some or all of the following:

- (1) The vessel is not currently documented by the Coast Guard.
- (2) The vessel will carry no passengers or cargo.
- (3) The vessel will be towed and unmanned.
- (4) The vessel is making a one-way voyage for purposes of scrapping or permanent removal from navigation.
- (5) The vessel is not intended to be used in commerce during the voyage.
- (6) The vessel will pose no threat to life, property, or the environment while in U.S. waters.

**NOTE:** Such vessels require a Load Line Exemption Certificate. See MSM Volume IV, Technical, COMDTINST M16000.9 (series), Chapter 6 for guidance.

- b. U.S. Customs and Border Protection has determined that, although such vessels require clearance before being towed to a foreign port, verification by the OCMI to the effect that "[name of vessel], being towed on a one-way voyage for purposes of scrapping, etc., is not required to hold a COI" will suffice for clearance purposes should appear on the loadline exemption certificate.
- c. Carriage of scrap. Scrap metal carried for ballast in such vessels will not be classed as cargo as long as the amount, location, and method of stowage of scrap is acceptable to the OCMI and does not exceed the tonnage of liquid ballast that would normally be employed. This is so that such vessels may meet the requirements given above. When the matter of what constitutes cargo is at issue, Commandant (CG-CVC) should be consulted.
- d. Requirements for passage through the St. Lawrence Seaway. Vessels subject to the Load Line Acts 46 U.S.C. 5102 and transiting under their own power to a non-U.S. port for decommissioning require load line certificates, COIs, and all other applicable statutory certificates before leaving a U.S. port.

**SECTION B: DOMESTIC INSPECTION PROGRAMS****CHAPTER 1: INSPECTION OF VESSELS FOR CERTIFICATION**

- (1) This policy is not intended to contravene or supersede requirements of the Canadian government with respect to passage through Canadian waters and clearance from Canadian ports. Owners of vessels transiting under their own power for decommissioning should contact the Director, Marine Regulations Branch, Department of Transport, Ottawa, Ontario, Canada, for further information in this regard.
- (2) Owners of such vessels intending to transit the waters of other countries should contact officials of those countries. The issuance of an International Load Line Exemption Certificate, by the local OCMI may be necessary. For further information and guidance, see MSM Volume IV, Technical, COMDINST M16000.9 (series), Chapter 6, and for applicable regulations, see 46 CFR 42.03-30(b)(3).

---

**9. Vessels Operating in South-Eastern Alaska**

46 CFR 2.01-80 states that the waters of southeastern Alaska inside of the general trend of the shore from Cape Spencer, southeasterly to Cape Muzon, and thence easterly to Sitklan Island, must be considered "lakes, bays, and sounds other than the Great Lakes" for administration of the vessel inspection laws and regulations. The waters between southeastern Alaska and Prince Rupert, BC, via Chatham Sound likewise have been classed "lakes, bays, and sounds" for purposes of vessel inspection. The "Inside Passage" between southeastern Alaska and Puget Sound is considered "lakes, bays, and sounds" for inspection and licensing purposes only if certain conditions are met. Approval by Commandant (CG-CVC) is required for vessels to operate between southeastern Alaska and the state of Washington under these considerations.

---

**10. Dual Certification for Passenger-Carrying Vessels and Sailing School Vessels**

Under existing regulations, a qualifying vessel may be operated in service part-time as a sailing school vessel (46 CFR Subchapter R) and at other times as a passenger-carrying vessel (46 CFR Subchapter T or H). 46 CFR 169.103(b)(5) states that the sailing school regulations are not applicable when a vessel is operating under the authority of a current valid COI as a passenger vessel. This regulation was written specifically to clarify the dual service situation. Although the regulations allow for dual certification, the OCMI may be reluctant to issue a certificate, let alone two, without conducting an inspection each time the operator physically alters the vessel as it shifts from one service to the other. General practice is to issue only one certificate at a time for the appropriate service, thus creating both an administrative and an inspection burden each time the vessel changes service. Alternatively, the OCMI may issue a single COI, under the conditions addressed below, to cover both services.

**SECTION B: DOMESTIC INSPECTION PROGRAMS****CHAPTER 1: INSPECTION OF VESSELS FOR CERTIFICATION**

- a. Single COI for predominant service. OCMI may issue a single COI for the vessel's predominate service with an endorsement for the alternative service.
- (1) Before issuing such a COI, the OCMI should be reasonably satisfied that the vessel is constructed, maintained, and outfitted in compliance with the applicable regulations regardless of which service the vessel is in at any given time. This requires the vessel to meet the more stringent requirements between 46 CFR Part 169 and either 46 CFR Subchapter H or T at all times.
  - (2) This procedure should enable the OCMI to avoid some degree of inspection each time the vessel shifts from one service to the other. With the vessel's material condition and outfitting fixed, operating conditions, manning, and possible total persons allowed may vary depending upon the applicable regulations within Subchapters H or T and can be addressed accordingly in the endorsement for the alternative service.
  - (3) In cases where the OCMI finds it appropriate and practicable to permit outfitting to vary, such variance should also be addressed in the endorsement.
- b. Period of validity. A vessel owner or operator must accept the application and maintenance of the more stringent regulations as a requisite to obtaining the benefits of a single COI, as opposed to trading COIs every time the vessel changes service and submitting to inspection as deemed necessary by the OCMI. Therefore, regardless of the predominate service under which the vessel's COI is issued, the vessel must be certificated for a period that is consistent with the more stringent regulations, whether they are for the predominate service for which the certificate is issued or the lesser service for which the endorsement is added. The intervals for inspections and drydock and tailshaft exams must also be based upon the more stringent regulations.

---

**11. Inspection of U.S. Vessels in Foreign Countries**

The following offices have responsibility for the listed foreign marine inspection regions:

- a. Sector Puget Sound: western coast of Canada.
- b. Sector San Diego: western coast of Mexico north of latitude 20 North.
- c. Sector New Orleans: South and Central America, the western coast of Mexico south of latitude 20 North, and all of the eastern coast of Mexico.
- d. Sector Boston: eastern coast of Canada.

## SECTION B: DOMESTIC INSPECTION PROGRAMS

## CHAPTER 1: INSPECTION OF VESSELS FOR CERTIFICATION

- e. **Sector Miami:** Bahamas
- f. **Sector San Juan:** Carribean
- g. **Sector Honolulu:** Pacific Islands
- h. **Sector Guam:** Pacific Islands
- i. **Far East Activities:** Asia and Diego Garcia.
- j. **Activities Europe:** Europe, the Mediterranean Sea, the Red Sea, the Persian Gulf, the Arabian Sea, and all of Africa.

**NOTE:** For areas in question or new construction projects, contact Commandant (CG-CVC).

---

## 12. Overseas Inspection Fees

**Payment of user fees and overseas inspection expenses(46 CFR 2.10-120. An overseas fee will be charged each time a set of travel orders are issued for an inspector to inspect a vessel overseas. Even if subsequent trips are for the same activity, an additional user fee will be charged prior to conducting the inspection/exam.**

**Policy Exception:Local Inspection - For overseas inspections performed within a reasonable travel distance, an overseas inspection fee will be charged ONCE for an inspection activity which provides CG credit (i.e. COI, annual, hull, certificates issued etc.) regardless of the number of visits. If no credit or certificate is requested (IE non-targeted ACP DD), no overseas inspection fee will be accessed.**

- a. **New Construction – An overseas inspection fee shall only be assessed ONCE for any new construction or conversion project that requires multiple visits.**
- b. **Deficiency checks/damage survey - If a TONO is issued for an inspector for sole purpose of clearing a deficiency or conducting a damage survey, then an overseas inspection fee will be assessed. If inspectors are already in the local area, an overseas inspection fee will not be assessed.**

**SECTION B: DOMESTIC INSPECTION PROGRAMS**

**CHAPTER 1: INSPECTION OF VESSELS FOR CERTIFICATION**

Policy continues on B1-9.

## SECTION B: DOMESTIC INSPECTION PROGRAMS

## CHAPTER 1: INSPECTION OF VESSELS FOR CERTIFICATION

---

**13. Certification of Vessels Undergoing a Reflag and/or Major Conversion**

- a. NVIC 10-81, CH-1, was developed to allow certain categories of existing foreign-flag vessels to be brought under the U.S. flag in a manner consistent with the principles and levels of safety in current Coast Guard regulations or, in some cases, to Coast Guard standards in effect at the time of the vessel's construction.
  - (1) The NVIC makes reference to acceptance of vessels between 2 and 10 years old for reflag and conversion. Older vessels will not be precluded if they can meet the SOLAS Method I-C Structural Fire Protection Requirements, as amended in 1981, in addition to all other requirements prescribed in NVIC 10-81 CH-1.
  - (2) In addition, this NVIC can be used as a guideline for existing vessels that undergo a major conversion, are brought under Coast Guard inspection, or wrecked vessels that are able to register under 46 U.S.C. 12107.
- b. Major conversion determinations. Determinations of major conversions are made by Commandant (CG-CVC). It is important that vessel owners contemplating work that may constitute a major conversion contact Commandant (CG-CVC) as soon as they have a general concept of the work to be performed so it can be reviewed. The Coast Guard bases major conversion determinations on 46 U.S.C. 2101(14a). This defines major conversion as a conversion that--
  - (1) Substantially changes the dimensions or carrying capacity of the vessel;
  - (2) Changes the type of the vessel;
  - (3) Substantially prolongs the life of the vessel; or
  - (4) Otherwise changes the vessel so that it is essentially a new vessel.
- c. Special provisions for the reflag of vessels participating in the Maritime Security Program (MSP):

## SECTION B: DOMESTIC INSPECTION PROGRAMS

## CHAPTER 1: INSPECTION OF VESSELS FOR CERTIFICATION

- (1) **Background.** **The Maritime Security Act of 1996 became law as an amendment to Title VI of the Merchant Marine Act of 1936. The Maritime Security Act of 2003 superseded the 1996 Maritime Security Act and reauthorized the Maritime Security Program under 46 U.S.C.A. 53102.** The Maritime Security Program (MSP) is administered by the U.S. Maritime Administration (MARAD) Office of Sealift Support (MAR-630) and establishes a program for direct U.S. government payment to private vessel owners for the right to use designated U.S. flag vessels to carry military cargo in time of war, national emergency, or military contingency.
  - (a) These privately owned and operated commercial vessels will normally be employed in commercial operations unless called upon by MARAD for military operations. Foreign flag vessels may apply for MSP but must reflag to U.S. flag as a condition of participation.
  - (b) MSP vessels are not (and will not become, even upon activation) public vessels as defined by 46 U.S.C. 2101 (24). MSP vessels must be U.S.-documented vessels, subject to inspection and certification by the Coast Guard.
  - (c) Separate legislation in the Coast Guard Authorization Act of 1996 (PL 104-324) provides that reflagged MSP vessels only need to comply with ABS class rules (or the rules of another class society accepted by the Coast Guard) and international convention requirements if the vessel meets the eligibility conditions discussed in the following paragraphs.
- (2) **Eligibility conditions for reflag under MSP.** The Coast Guard may accept previously conducted class society surveys and previously issued international certificates in lieu of establishing equivalency to U.S. regulations for all vessel equipment and systems, provided that--
  - (a) The vessel is classed by and designed in accordance with the rules of the ABS or another classification society accepted by the Coast Guard;
  - (b) The vessel complies with applicable international agreements and associated guidelines, as determined by the country in which the vessel was documented immediately before becoming a U.S. documented vessel; and
  - (c) That the country under which the vessel is currently flagged has not been identified by the Coast Guard as inadequately enforcing international vessel regulations on the vessel making application for certification.
- (3) **For MSP and application for inspection.** In order to carry out the conditions described in the paragraph above, the following procedure must be followed to issue the initial COI and international certificates for a foreign vessel entering MSP.



**SECTION B: DOMESTIC INSPECTION PROGRAMS****CHAPTER 1: INSPECTION OF VESSELS FOR CERTIFICATION**

- (a) MARAD Headquarters (MAR-630) will notify Commandant (CG-CVC) when a foreign flag vessel is being considered for selection for participation in MSP. CG-CVC will conduct a review of the vessel's Port State Control boarding history in MISLE and notify MARAD of any significant instances of past non-compliance with international regulations. MARAD will notify CG-CVC and the vessel owner if the vessel has been selected for MSP participation.
- (b) The vessel owner will apply for inspection to the OCMI in whose zone the reflag inspection will be conducted. If that location is not known at the time of acceptance into MSP (to facilitate timely plan review) the owner may make application to Commandant (CG-CVC) who will hold the application for forwarding to the cognizant OCMI when an inspection location has been selected. CG-CVC will provide a copy of the application to Commanding Officer, Marine Safety Center (MSC).
- (4) Plan review to verify SOLAS compliance for MSP. The vessel owner must submit the items below to the Commanding Officer, MSC for review to verify compliance with SOLAS, MARPOL, ICLL, and that the vessel is designed in accordance with the rules of the ABS or other accepted class society.
  - (a) When the vessel has been classed and designed in accordance with rules other than ABS, the MSC must determine acceptance on a case-by-case basis for the purpose of MSP participation only. This acceptance of class rules and design for MSP must not be construed as acceptance for any other inspection program.
  - (b) The vessel's owner, flag administration, and class society must identify all areas where previous equivalence or exception has been granted to SOLAS, MARPOL, ICLL, the design rules of the ABS, or other accepted class rules.
  - (c) Plans to be submitted. The following plans must be submitted:

## SECTION B: DOMESTIC INSPECTION PROGRAMS

**CHAPTER 1: INSPECTION OF VESSELS FOR CERTIFICATION**

- [1] General arrangement plans.
  - [2] Structural fire protection division rating plans (assuming Method I construction, MSC will spot check fire boundary ratings and ventilation details, i.e., penetrations by the ventilation system of fire rated divisions).
  - [3] Fire detection system plans (to verify placement and overall system design).
  - [4] Fixed fire extinguishing system plans (a minimum 20 second time delay for releases into manned spaces must be required even though this is not specified in SOLAS).
  - [5] Automation system plans including a qualitative failure analysis for vital systems, or a letter from the class society stating that the systems are designed to meet the failsafe requirements of SOLAS.
- (d) Plans to be submitted for verification of class approval. The following information/plans and class society approval letters must also be submitted, but generally will be examined only to verify the approval action of the class society and will not undergo MSC design review or OCMI inspection unless problems or unusual items are noted:
- [1] Trim and stability booklets, including lightship properties and stability test data.
  - [2] Letter from the flag administration or class society indicating the vessel meets probabilistic damage stability requirements for vessels built after 1 February 1992.
  - [3] Letter from flag administration or class society indicating review/approval of the following items, with notes about all areas that require special attention/inspection, such as--
    - aa. Structures;
    - bb. Fire main systems;
    - cc. Bilge systems; and
    - dd. Steering gear and steering gear alarm systems.

**SECTION B: DOMESTIC INSPECTION PROGRAMS****CHAPTER 1: INSPECTION OF VESSELS FOR CERTIFICATION****(5) OCMI inspection for initial certification.****(a) Issuance of the initial COI is subject to the following:**

- [1] A satisfactory onboard inspection by the cognizant OCMI, conducted with a surveyor from the vessel's class society or flag administration who can explain interpretations of SOLAS, MARPOL, and the International Convention on Load Lines.
- [2] The owner must provide the OCMI with access to the last annual survey report of the class society, the list of outstanding class recommendations and statutory requirements, and the latest drydock survey report (including latest gaugings).
- [3] A list of all systems, equipment or other items that meet a standard different from the U.S. statutory requirements for a vessel of that size and service. (e.g. pressure vessels that are not ASME stamped or lifejackets that are not Coast Guard approved).
  - aa. This list is consistent with Coast Guard reflag policy of the past which has shown that the ability to rapidly identify these items greatly speeds the initial reflag inspection.
  - bb. The list will allow inspectors to identify and document items in the vessel's inspection record that meet international, class or previous flag administration interpretations of standards. This is necessary to avoid duplication of this effort at subsequent inspections. It will also eliminate the need for the owner to continue providing a representative of previous flag administration at subsequent inspections.

**(b) Conduct of the inspection.** The initial inspection must be sufficiently detailed to verify full compliance with international regulations. The procedures applicable to foreign vessel port state control annual examinations described in MSM Volume II, Material Inspection, M16000.7 (series) Chapter D1 must be used as a guideline for the scope of the initial inspection.

- [1] The inspector must consult the class society/flag administration representative in attendance when the inspector requires guidance as to the application of a particular international regulation. If the class society/flag administration representative in attendance verifies that the item in question is satisfactory under their guidelines, the OCMI will accept it. At the conclusion of the inspection, the inspector must make a special note in MISLE documenting all items on the vessel that are found to be acceptable to the class society/flag administration representative, but that

## SECTION B: DOMESTIC INSPECTION PROGRAMS

**CHAPTER 1: INSPECTION OF VESSELS FOR CERTIFICATION**

are treated differently under current Coast Guard policy. (NVIC 10-81, CH-1, provides a useful summary of Coast Guard requirements to use as a comparison to international requirements.)

- [2] Satisfactory fire and abandon ship drills must be performed in the presence of the Coast Guard marine inspector. The drills must be conducted by the vessel's U.S. crew prior to issuance of the initial COI.
- [3] In addition to the inspection described in MSM Volume II, Material Inspection, COMDTINST M16000.7 (series), Chapter D1, the inspector may verify that all current structures, equipment or systems on the vessel are in agreement with the plans reviewed by the MSC or approved by the class society and/or flag administration. The scope of the plan's verification is at the OCMI's discretion, but should generally be conducted as a spot check.
- (c) Engine automation test. If the vessel requests reduced manning as a result of engine automation then the automation test procedure and approval must be in accordance with U.S. regulations and vessel inspection policy (e.g. NVIC 1-69, NVIC 6-84 and NVIC 10-81, CH-1). The MSC will review the test procedure (see C of this chapter). The final manning requirements must be established based on satisfactory verification of the engine automation, as outlined in NVIC 1-69.
- (d) Deficiencies. Any area considered deficient as a result of the Coast Guard examination described in MSM Volume II, Material Inspection, M16000.7 (series), Chapter D1 (annual examination) must be subjected to an expanded examination based on the principle of "clear grounds" as defined in that chapter.
- (e) Drydocking/internal structural examination. A separate drydock examination and comprehensive internal structural examination (including entry and examination of ballast tanks and double bottoms) is only required in conjunction with the initial COI if clear grounds exist to require it. The drydock date should be consistent with the previously established dates set by the flag administration and/or class society. If the credit drydock and/or internal examination coincides with the initial COI, the inspector must conduct the examinations in accordance with the guidelines established by the previous flag administration and/or class society.
- (f) Pollution prevention. The vessel must comply with all U.S. regulations and international pollution prevention requirements that would be applicable to a foreign vessel calling in a U.S. port.
- (g) Issuance of certificates upon satisfactory initial examination:

## SECTION B: DOMESTIC INSPECTION PROGRAMS

## CHAPTER 1: INSPECTION OF VESSELS FOR CERTIFICATION

- [1] COI. Upon satisfactory completion of the initial inspection, the vessel will be issued a COI for the route and service specified on its existing statutory certificates. A reduction in manning due to engine automation must be approved and tested as satisfactory in accordance with U.S. regulations and policy for reflags conducted under NVIC 10-81 (CH-1). The OCMI must place the following endorsement on the COI and as a special note in MISLE:

“This vessel is certificated under the provisions of the Maritime Security Program (MSP) and is inspected and certificated solely in accordance with the requirements of class rules and international convention requirements as applicable. This vessel was issued its initial certificate of inspection in accordance with the MSP on DD MM YY.” (Insert date inspection is complete.)

- [2] International convention certificates. SOLAS, MARPOL, and ICLL certificates will be issued by the Coast Guard or by a Recognized Organization that is authorized to issue the certificate on behalf of the Coast Guard. This includes authorization granted under existing agreements, new agreements under 46 CFR Part 8, or the Alternate Compliance Program (ACP).
- [3] OCMI must document any areas where the previous flag administration or class society accepted a system or equipment that differs either from the Coast Guard's statutory requirements or Coast Guard enforcement of international regulations. OCMI must also note such occurrences as a special note in MISLE.
- (h) OCMI action if initial inspection is unsatisfactory. If the Coast Guard's initial inspection yields sufficient evidence to show that the country under which the vessel is currently flagged has been inadequately enforcing international vessel regulations on the vessel applying for certification, the COI must be withheld and Commandant (CG-CVC) notified.

## SECTION B: DOMESTIC INSPECTION PROGRAMS

## CHAPTER 1: INSPECTION OF VESSELS FOR CERTIFICATION

- [1] Commandant (CG-CVC) will notify MARAD that the vessel is not currently acceptable to receive a COI. Commandant and MARAD will then consult as to whether the vessel should be allowed to make repairs or modifications in order to complete certification for entry into MSP, or whether the vessel should be excluded from MSP participation.
- [2] OCMI's are strongly encouraged to call upon the assistance of the traveling inspectors at Commandant (CG-54-TI) when the initial inspection of an MSP vessel indicates clear grounds for an expanded examination.
- [3] Payment of user fees and overseas inspections expenses. User fees must be paid prior to the initial inspection for certification. Travel and per diem costs for overseas inspections must be paid in advance on a cost estimated basis. If owners cannot arrange for advance payment of user fees or travel costs (overseas only) due to scheduling difficulties, then Commandant (CG-CVC) must be contacted to determine if a delay in payment will be permitted until after the inspection has commenced.
- (6) Inspection of MSP vessels subsequent to initial inspection. MSP vessels will continue to be inspected under the preceding guidelines for all subsequent inspections except as noted below.
- (a) Intervals for subsequent inspection must be in accordance with international convention certificate requirements.
- (b) Vessels accepted under MSP reflag must be reissued a COI every 5 years upon application from the owner if the vessel has completed all scheduled inspections for the maintenance of class and international convention certificates (including all annual endorsements, surveys and drydockings).
- (c) OCMI's must continue to conduct inspections in accordance with the class rules, SOLAS, MARPOL, and ICLL. Situations when the previous flag administration or class society accepted a system or equipment prior to reflag which differs from the Coast Guard's current statutory or policy interpretation for the implementation for that international regulation (at the time of the initial inspection) should have been recorded as a special note in MISLE at the initial inspection. New installations or modifications to existing systems made subsequently to the initial reflag must conform to the Coast Guard's interpretation of international regulations at the time of the modification, so far as reasonable and practical.
- (d) MSP vessels that elect to enroll in the ACP may employ ACP inspection procedures subsequent to the initial reflag inspection, which will be conducted by the Coast Guard.

**SECTION B: DOMESTIC INSPECTION PROGRAMS****CHAPTER 1: INSPECTION OF VESSELS FOR CERTIFICATION**

- (e) User fees must be paid in a manner consistent with all U.S. certificated vessels.

---

**13. Vessels of Novel Design**

- a. Proposed operation. From time to time, an OCMI will be approached with some novel operation proposal that is not covered by any regulation. In such cases, the OCMI will coordinate the proposed operation and associated inspection requirements through the District Commander (p) to Commandant (CG-CVC).
- b. Regulatory requirements. Commandant (CG-CVC) will consult with the cognizant OCMI to determine the level of regulation that will be applied to vessels in “novel” operations not covered by any or part of regulations.

---

**C. PRE-INSPECTION PROCEDURES**

---

**1. Application for Inspection of U.S. Vessel, Form CG-3752**

Applications for inspection for certification must be submitted to the cognizant OCMI by the vessel’s master, owner, or agent on Application for Inspection of US Vessel, Form CG-3752 (see 46 CFR 2.01-1). The application for initial inspection of a vessel being newly constructed or converted must be submitted prior to the start of such construction or conversion. This must be followed by the submittal of plans and specifications required by the applicable regulations.

In the event of an office receiving an application for construction/conversion of a vessel that is not under that office’s jurisdiction, the application should be forwarded to the appropriate OCMI and the applicant so advised. Inspection for certification must not commence until a proper application has been submitted by a U.S. citizen and the proposed operation of the vessel (use, route, passengers, etc.) is known to the OCMI and the inspector.

---

**SECTION B: DOMESTIC INSPECTION PROGRAMS****CHAPTER 1: INSPECTION OF VESSELS FOR CERTIFICATION****2. Preparation by the Inspector**

The marine inspector must be as well informed as possible of the vessel's proposed operation (and its past history, as applicable) before commencing the inspection. Due to the many differing circumstances encountered, the availability of such information will vary.

Generally, the following procedures should be used:

- a. Prior to conducting any inspection service that is related to the compliance of its COI, marine inspectors shall ensure the appropriate Application for Inspection form (CG-3752) is properly filed and verify that the required annual vessel inspection user fee has been paid. 46 CFR 2.10 establishes inspection and examination fees for all vessels required to have a COI. User fee invoices are automatically generated for vessels with valid COIs. Additional fees are also required for inspections and examinations conducted at overseas locations.
- b. Before beginning the inspection, the inspector should review the vessel's previous inspection records. For initial inspection, the inspector should also review copies of all approved plans, specifications, and relevant correspondence, and any record of outstanding deficiencies.
- c. When the owner, agent, or master of a vessel previously inspected in another zone applies for inspection, the OCMI should obtain the inspection records for the previous inspection for certification and drydocking examination from the certifying OCMI. Such records should be returned after the inspection is completed, unless the vessel has permanently changed its principal port of operation to the zone where inspected. See MSM Volume II, Material Inspection, COMDTINST M16000.7 (series), Chapter A2 for more information.

---

**D. CONDUCTING INSPECTIONS FOR CERTIFICATION**

---

**1. Initial Inspections**

- a. Definition. The initial inspection for certification is the first inspection held on a vessel during or after construction or conversion. It is a prerequisite to the issuance of the original COI.
- b. Purpose. At the initial inspection, the inspector ascertains that the vessel has been built (or converted) and equipped in accordance with the applicable regulations, construction standards, and approved plans and specifications, and that its condition is such that it can be operated with safety of life and property in the service and route(s) specified. The inspector also ensures that the condition and installation of all equipment and associated apparatuses comply with applicable regulations.



**SECTION B: DOMESTIC INSPECTION PROGRAMS****CHAPTER 1: INSPECTION OF VESSELS FOR CERTIFICATION**

- (1) The initial inspection should be carried out with special attention to detail.
  - (2) All unusual circumstances that require interpretations of regulations, special considerations, the use of substitutions or equivalents, etc., must be carefully considered and the decisions well documented in the MSLE activity narrative and/or inspection notes.
- c. Policies concerning ABS-classed vessels. NVIC 10-82 clearly establishes guidelines for the acceptance of ABS plan review and inspection during the initial inspection. This NVIC delineates areas of shared reviews and inspections and areas retained solely by the Coast Guard. Most ABS-classed vessels will fall under NVIC 10-82.
- (1) An example of shared review and inspection is an Inert Gas System (IGS) or Crude Oil Washing (COW) system installed in a vessel for which the owner has requested ABS review and inspection. In this situation, the Coast Guard would accept ABS approval and inspection if ABS provides a letter certifying that the systems are in compliance with regulatory requirements.
  - (2) When the provisions of NVIC 10-82 are not followed, ABS will perform plan review and inspection for class only, and will not review or inspect for regulatory requirements. In these cases, the Coast Guard will complete the plan review and inspection requirements.
  - (3) NVIC 10-82 also applies to major conversions. Questions concerning the applicability of NVIC 10-82 must be referred to Commandant (CG-CVC) for resolution. For further information on stability see NVIC 3-97, "Stability Related Review Performed by The American Bureau of Shipping for U.S. Flag Vessels."
- d. Conducting the inspection. When possible, the initial inspection must be conducted throughout the vessel's construction and fit-out period, with a final review of the condition of the vessel and its equipment upon completion of the construction and fit-out.
- (1) Vessels being converted must be inspected throughout the conversion period.
  - (2) The inspector must bring any defects noted to the attention of the builder and contractor as soon as possible so that timely corrections can be made.
  - (3) The inspector must notify the OCM I of any controversial items so that they may be resolved, if possible, before work continues.
  - (4) See MSM Volume II, Material Inspection, COMDTINST M16000.7 (series), Chapter A2 concerning the handling of deficiencies.



**SECTION B: DOMESTIC INSPECTION PROGRAMS****CHAPTER 1: INSPECTION OF VESSELS FOR CERTIFICATION**

- e. Scope of the inspection. The inspection must be sufficient to determine the following:
- (1) That the vessel is suitable for the service and route(s) in which it is to be employed.
  - (2) That the vessel is equipped with the proper lifesaving and fire protection appliances as prescribed by the regulations.
  - (3) That the vessel has suitable accommodations for passengers and crew.
  - (4) That the vessel is in a condition to warrant the judgment that it may be used in navigation with safety to life, property, and the environment.
  - (5) That the vessel fully complies with the requirements of applicable statutes and regulations, including those for pollution prevention and navigation safety in all other respects.
- f. Compliance with plans and specifications. The inspector must have corrected copies of the approved plans and specifications available when inspecting new construction or conversion. These are considered work copies, for the use of the inspector during construction and for the OCMI's files after construction. If additional copies are needed for office use or filing, they must be requested from the submitter.
- (1) Most plans and specifications are approved subject to comments in their transmittal letters. These letters are referred to in the approved plans and specifications and must be made available to the inspector who oversees the construction or conversion work. When approval is given subject to comments or recommendations of ABS or another recognized classification society, such comments or recommendations must also be made available to the inspector.
  - (2) Since equipment and system installations must be completed to the satisfaction of the OCMI, the inspector must check the complete installation for safety and compliance with applicable standards, as well as the plans and specifications. Any errors or omissions in plans that would result in unsafe conditions or noncompliance with applicable standards must be promptly brought to the attention of the builder and the OCMI for resolution.
- g. Restricted visibility from the navigating bridge. Restricted visibility from the navigating bridge is most often encountered on container vessels, large tank vessels with the bridge aft, vessels with oversize cargo handling gear, and special purpose vessels such as MODUs and crane ships; however, it may occur on any type of vessel.

## SECTION B: DOMESTIC INSPECTION PROGRAMS

## CHAPTER 1: INSPECTION OF VESSELS FOR CERTIFICATION

- (1) In most cases, this problem will be identified and resolved in plan review. In those cases when restricted visibility becomes apparent after the start of construction, the matter should be brought to the attention of the owner as early as possible, to avoid costly modifications late in the construction of the vessel. Technical guidelines for bridge visibility are contained in the MSM Volume IV, Technical, COMDTINST M16000.9 (series).
- (2) Causes of restricted visibility from the navigating bridge. These can be separated into two broad categories: those with a movable or temporary obstruction (such as container deck loads) and those with a permanent obstruction (as in a vessel structure).
  - (a) As situations of the first category are operational in nature, vessel certification should not be withheld for this type of visibility restriction. However, the problem should be brought to the attention of the owner so that the owner may take appropriate action to remove obstructions to visibility that interfere with the safe navigation of the ship.
  - (b) Situations of the second category are permanent in nature and cannot be operationally controlled after the vessel is in service. Therefore, a vessel with this type of obstruction should not be certificated when, in the opinion of the OCMI, visibility from the navigating bridge is restricted to such a degree that the vessel cannot be navigated safely.

**NOTE:** Tinted windows may also restrict visibility. They are prohibited by regulation (e.g., 46 CFR 92.03-1(c)) and by policy to meet the intent of the requirements of 33 CFR Part 164 to maintain clear unobstructed visibility for promoting safe navigation; unless it can be demonstrated that the amount of light transmitted through them is equivalent to that transmitted through clear glass.

- h. Trial trips. An inspector is required to observe the operation of each new vessel during a trial trip, once the vessel is complete and before initial certification. The specific regulations covering trial trips are in 46 CFR 58.01-30 and also in 46 CFR 31.10-40 for tank vessels. A vessel on a trial trip is not required to have a COI or a Coast Guard-issued certificate of documentation.
  - (1) For practical purposes, a new vessel on a trial trip is not required to be fully compliant with all COI requirements, because the trip is--
    - (a) Usually of short duration;
    - (b) Frequently made with Coast Guard inspectors aboard;

**SECTION B: DOMESTIC INSPECTION PROGRAMS****CHAPTER 1: INSPECTION OF VESSELS FOR CERTIFICATION**

- (c) One of the final incidents of Coast Guard inspection prior to the initial issuance of a COI; and
  - (d) Usually made with the equipment required for a COI, with the vessel operated by licensed and certificated personnel.
- (2) An inspector observing a trial trip does not supervise and instruct vessel personnel. Specific matters may be referred to the inspector for advice, but the supervision of the tests according to the trial schedule rests with the builder's representatives. However, as part of the initial inspection of any vessel, the inspector may require such tests as he or she deems necessary to be assured of the safety and seaworthiness of the vessel.

---

**2. Subsequent Inspections for Certification**

- a. Intent. At subsequent inspections for certification, the inspector must ascertain that the vessel and its equipment are being maintained in a safe condition and in accordance with applicable laws and regulations, and determine whether changes have occurred in the vessel tending to make its continued operation unsafe. These subsequent inspections should be carried out with special attention to the condition of the vessel and its equipment.
  - (1) The inspector must be particularly alert for unauthorized changes to the vessel and its equipment.
  - (2) Upon completion of the inspection, the inspector and the OCMI must be satisfied that the vessel may be operated safely in the proposed service for the period covered by the COI, and that it otherwise complies with the applicable laws and regulations.
- b. Inspector's obligations. The inspector must use all available evidence when appraising the condition of a vessel and its equipment, including the latest inspection findings, records of previous Coast Guard inspections, the opinions or records of other interested surveyors or inspectors, information furnished by the officers and crew, facts concerning the vessel's classification, and previous certification. The inspector may seek the advice of experts in the particular field involved, such as boilermakers, shipfitters, and welders, or the opinion of more experienced inspectors or technical personnel assigned to his or her unit. Based on this evidence and his or her own inspection, the inspector must reach an independent conclusion as to vessel and equipment conditions and act accordingly. The OCMI must be consulted when there is doubt in the inspector's mind as to a proper course of action.

**NOTE:** See 46 U.S.C. 3315 concerning the disclosure of sources of information.

**SECTION B: DOMESTIC INSPECTION PROGRAMS****CHAPTER 1: INSPECTION OF VESSELS FOR CERTIFICATION**

- c. Scope of inspection. The inspection must be of sufficient scope to determine the following:
- (1) That the vessel has a structure suitable for the service in which it is to be employed.
  - (2) That the vessel is equipped with the proper lifesaving, fire protection appliances, pollution prevention, and navigation safety as prescribed by appropriate regulations.
  - (3) That the vessel has suitable accommodations for passengers and crew.
  - (4) That the vessel is in a condition to warrant the judgment that it may be navigated safely.
  - (5) That the vessel, in all other respects, fully complies with the applicable laws and regulations.
  - (6) That the vessel's boilers, unfired pressure vessels, and all appurtenances thereof, as well as the propelling and auxiliary machinery, the electrical apparatus, and all other equipment comply with the applicable laws and regulations.
  - (7) That the vessel may be safely employed in its proposed service.

---

---

**E. HULL INSPECTIONS**

---

**1. General Concerns**

The inspector must determine the adequacy of the complete hull structure by the review of plans before construction; review of approved plans during construction, reinspections of the hull after construction, and examination of any repairs or alterations.

In certain cases, the OCMI may accept approved plans and the ABS Classification Certificate as evidence of the structural efficiency of the hull. However, the inspector must perform sufficient examinations and tests of the hull structure at the inspection for certification to determine that the condition of the hull is suitable for the vessel's service and is such that the vessel may be navigated safely.

Additionally, all protected and unprotected saltwater ballast tanks must be inspected at least twice in a 5-year period. The inspector must indicate which tanks have been examined.

## SECTION B: DOMESTIC INSPECTION PROGRAMS

**CHAPTER 1: INSPECTION OF VESSELS FOR CERTIFICATION**

The inspector must ensure that the regulations regarding watertightness and weathertightness of the hull, including weather decks, are strictly enforced. The inspector must give particular attention to cargo hatches, closures, securing devices, gaskets, means of attachment, etc.

---

**2. Older Vessels**

- a. Inspection of older vessels. The determination of the true condition of a vessel and its equipment may be more difficult for an older vessel. The inspector should make every effort to research an older vessel's records to detect any recent structural, machinery or equipment failures/problems. An increase in the rate of failures may indicate a general deteriorating condition.
    - (1) The inspector is not limited by regulations from making tests or inspections as he or she deems necessary to be assured of the safety and seaworthiness of the vessel. Tests and inspections may include machinery tests, hull gauging (see F.3 below), inspections of equipment, etc., regardless of regulatory requirements or the type of inspection being performed (e.g., inspection for certification, reinspection, drydocking, or deficiency check.)
    - (2) The inspector should review the most recent hull gauging report as an aid in determining--
      - (a) Whether additional or new gauging is called for; and
      - (b) What area(s) of the hull might require special attention.
    - (3) Traveling Inspector (CG-54-TI) notification. Commandant (CG-5P-TI) must be notified when any vessel 20 years of age or older and over 4,000 GT is scheduled for an inspection for certification and/or drydocking. Traveling inspectors will attend selected older vessel inspections; therefore, notification as far in advance as possible is required.
    - (4) Special consideration. For those vessels that are not required to meet the load line regulations, special consideration must be given to hull structure and arrangement, freeboard, protection of openings, drainage, and the other items normally considered in the issuance of a Load Line Certificate. Since these items will not be checked by a load line "assigning authority," they must be attended to by the inspector.
-

**SECTION B: DOMESTIC INSPECTION PROGRAMS****CHAPTER 1: INSPECTION OF VESSELS FOR CERTIFICATION****3. Hull Gaugings**

NVIC 7-68, "Notes on Inspection and Repair of Steel Hulls," gives guidance as to when an inspector should require limited or belt gauging. NVIC 7-68 urges the inspector to witness gauging at any periodic survey and make use of the results.

Additional gauging or gauging at an inspection that does not coincide with an ABS special survey should be required by the inspector when deemed necessary in order to determine the seaworthiness of a vessel. As per ABS rules, "The first Special Periodical Survey becomes due 4 years after the date of build. Subsequent Special Periodical Surveys are due four years after the previous Special Survey." ABS may defer special surveys for up to 12 months.

---

**4. Load Lines**

Certain vessels in ocean, coastwise, or Great Lakes service are required to meet the requirements of 46 CFR Subchapter E (Load Lines) with respect to strength, closure of openings, protection of openings, guardrails, freeing ports, means of access, etc.

Inspections for compliance with these regulations are made by ABS or another assigning authority approved by the Commandant. A current Load Line Certificate will normally be accepted by the surveyor or inspector as evidence that the vessel meets the requirements of 46 CFR Subchapter E.

Although load line assignments are made by an assigning authority, the enforcement of load line requirements rests with the Coast Guard. Therefore, marine inspectors should examine the weathertightness of cargo and other hatchways covered under the load line regulations during routine vessel inspections.

If the surveyor or an inspector discovers that a vessel holding a current Load Line Certificate is not in compliance with the regulations, or that the condition of any fitting covered by such regulations is not satisfactory, they must inform the OCMI and ensure corrective action to achieve compliance is taken.

- a. Weathertight and watertight. For regulations concerning weathertight and watertight standards, see 46 CFR 42.09-25(b)(3), , and 42.15-30. See also paragraph 6.F.5 below.
- b. Master's responsibility. Regulations also task the vessel's master with the responsibility of ensuring that all exposed cargo hatches are properly secured prior to leaving protected waters. See 46 CFR 78.17-35, 97.15-20, and 196.15-20.



## SECTION B: DOMESTIC INSPECTION PROGRAMS

## CHAPTER 1: INSPECTION OF VESSELS FOR CERTIFICATION

**5. Watertight and Weathertight Inspections**

At inspections for certification, the adequacy of watertight and weathertight fittings and closures will be determined. An operational test of hatch covers will normally be witnessed and tightness of hatch covers verified. If practicable, such tests should be performed at the same time that the load line-assigning authority is performing an annual or periodic load line survey.

During periodic inspections, watertight and weathertight closures and fittings must be examined to the extent necessary to ensure that they are being properly maintained. The following additional guidance and standards apply to watertight and weathertight inspections:

- a. Watertight. Watertight closures such as cargo ports and other similar openings in the sides of vessels below the freeboard deck must be designed to ensure the same watertightness and structural integrity commensurate with the surrounding shell plating (46 CFR 42.15-55). The small passenger vessel regulations previously defined watertight as to effectively resist the passage of water when subjected to a hose test of 30 psi. Gaskets must be clean (unpainted) and flexible to provide a tight seal. Coamings and knife-edges should be structurally sound, straight, and true.

**NOTE:** For vessels inspected under Subchapter T and Subchapter K., see 46 CFR 179.310, and 46 CFR 116.1160 respectively.

- b. Weathertight. Weathertight means that water will not penetrate into the vessel in any appreciable amount in any sea condition (46 CFR 42.13-15).
  - (1) Hatchcovers closed by portable covers must be secured weathertight as required in 46 CFR 42.15-25.
  - (2) Weathertight fittings for small passenger vessels must be constructed to effectively resist the passage of water to appreciable degree under continuous exposure to driving rain or spray. Vents, cowlings, coamings, etc., should be sound, properly fitted, and secured to prevent flooding from boarding seas.
- c. Vessels of unique design. Special emphasis on weather deck openings should be placed on vessels of unique design. Even a small amount of flooding can appreciably affect stability on MODUs, hovercraft, pontoon hulls, etc. The OCEAN RANGER casualty emphasized the need to prevent and detect flooding in unmanned spaces when the chain locker flooded from boarding seas. Chain locker covers serve to reduce the amount of downflooding through the spill pipe or spurling gate and can be made more weathertight by stuffing rags, cement, or gasket material around the chain prior to heavy weather.

**SECTION B: DOMESTIC INSPECTION PROGRAMS****CHAPTER 1: INSPECTION OF VESSELS FOR CERTIFICATION**

- d. Securing devices. Hinges, locking mechanisms, retaining brackets, dogs, and other securing devices should be sound and operate freely. Covers must be readily available and easily secured for closing in the event of fire as well as heavy weather.
- e. Repairs/Strength. All closures and securing devices must be able to withstand the forces of boarding seas. Repairs must maintain the structural integrity of the closure. Inspectors should not allow the use of plastic putty, e.g., "red hand," to repair strength members of cargo hatch covers. NVIC 7-68 must be used as guidance for the repair of steel hatch covers.
- f. Testing of closures. Testing of closures may be done visually by light testing, pressure testing, or hose testing. Watertight closures or fittings should be tested under the design pressure where practicable. Otherwise, a hose test over 30 psi may be accepted. Weathertight fittings should be hose tested for several minutes and allow no more than a slight seepage of water to pass. An operational test should be performed on hatch cover closure devices.
- g. Freeing ports. When conducting a compliance exam boarding of a fishing vessel or inspecting a charter fishing boat, inspectors should examine the freeing ports to ensure they are clear, and if fitted with "flapper" closures, that they are operable and will allow water on the deck to clear over the side. The charter fishing vessel COUGAR is an example of a vessel foundering and sinking due to an accumulation of water on the aft deck due to inoperable freeing ports.
- h. Hatches – watertight integrity. Manhole covers installed in watertight double bottoms on small passenger vessels must be inspected to ensure they meet a suitable watertight reliability performance standard.
  - (1) Inspectors should examine all hatch covers to ensure that the gasketing material is in place and that it provides the designed watertight integrity, and that the hinges and securing devices are operable. This includes all watertight doors, hatch covers, and manhole covers to all integral hull tanks (voids, ballast, etc.), especially the o-rings on the single bolt tank covers.
  - (2) A failed tank cover was identified as a problem in the grounding of the small passenger vessel YORKTOWN CLIPPER when the void tank cover o-ring failed causing flooding of the accommodation spaces.

---

**6. Bulkhead Penetrations**

The use of epoxy resin as a pipe seal in watertight bulkheads is considered satisfactory when the maximum piping temperature does not exceed 200°F and structural fire protection qualities are not required by the regulations. Accordingly, epoxy resin should only be used as a pipe seal in watertight bulkheads on passenger vessels if the passenger vessel is less than

## SECTION B: DOMESTIC INSPECTION PROGRAMS

## CHAPTER 1: INSPECTION OF VESSELS FOR CERTIFICATION

100 GT. The resin should be subjected to the appropriate standard fire test as required by 46 CFR Part 72.

---

---

**F. MACHINERY INSPECTIONS**

---

**1. General**

At each subsequent inspection for certification, the inspector must examine a vessel's machinery as required by law and regulations. Inspections and tests must be performed to ensure that main and auxiliary machinery, boilers and their appurtenances, and other equipment are in satisfactory operating condition and suitable for the intended service. To help with this determination, the inspector must ask the chief engineer or officer in charge of the machinery about possible defects or imperfections in the equipment, boilers, and machinery of the vessel.

**The inspector should keep safety requirements foremost in mind during the inspection of engineering equipment. The requirements of 46 CFR Subchapter F (Marine Engineering) and the instructions in this manual are not intended to cover all contingencies that may be encountered during an inspection. The inspector may require any reasonable tests or inspections deemed necessary to ensure the safety of the vessel. It is incumbent upon the inspector to be alert to unsafe conditions and to require corrective measures before these conditions can cause casualties.**

---

**2. References**

46 CFR Subchapters F and J contain the primary standards for the inspection of main and auxiliary machinery installations on all vessels except small passenger vessels inspected under 46 CFR Subchapter T. As indicated in 46 CFR 58.01-5, these standards are supplemented by the ABS's standards. 46 CFR Subchapter F regulations apply to T-boats only insofar as they are made applicable by 46 CFR Part 182. As provided in 46 CFR 167.25-1, boilers and pressure vessels and their piping and appurtenances on public nautical school ships must conform to the requirements of 46 CFR Subchapter F, or to U.S. Navy or Coast Guard Standard Construction Specifications.

---

**3. Vessels that are Not Classed**

On vessels that are not classed by a recognized classification society, the inspector must, when practicable, require and observe an operational test on all main and auxiliary machinery to determine that its condition is satisfactory. The inspector may require an operational test of any machinery when necessary to determine its condition.

**CHAPTER 1: INSPECTION OF VESSELS FOR CERTIFICATION****4. Inspection of Main Propulsion Machinery**

- a. **The inspector shall be generally guided by section B.1.F.1 above in the inspection of main propulsion machinery for certification. Typically, main and auxiliary machinery and associated equipment are tested at each inspection for certification and periodic inspections; see 46 CFR 61.20-3.**
- b. **Overspeed and low oil pressure trips. The inspector shall determine during inspection by whatever practical means may exist that the overspeed mechanisms, low lube oil pressure shut-down devices, turbine governor mechanisms, and throttle valves and their linkage are in proper operating condition. Where possible the inspector shall require operational tests to check these devices or mechanisms. Any malfunction of the foregoing items shall be corrected. Further references to low lube oil shutdowns can be found at 46 CFR 56.50-80(b), (g), and (i) and 46 CFR 58.05-10.**

**NOTE: Any operational tests of lube oil shutdown controls should not risk shutting off the oil supply to the bearings. Tests of the overspeed safety devices should be as per the approved automation procedures.**

- c. **Automated Machinery: When main propulsion machinery is automated, the equipment shall be witnessed by an inspector and verified to the system design requirements and regulations provided in 46 CFR 62 'Vital System Automation'. This is, in part, intended to address system updates or modifications and to ensure continued safe operation. Testing of all systems should be conducted in accordance with the approved periodic safety test procedures (PSTPs) and as described in 46 CFR 61.40-6 and 61.40-10.**
- d. **Main engine gravity-type lubricating systems. In one casualty reported aboard a C3-S-A2 cargo vessel, the propulsion turbines sustained extensive damage due to insufficient lubricating oil. Investigation revealed that a closed or partially closed valve in the piping system from the gravity tanks to the main engine caused a reduced flow of oil to the turbines. This valve was marked "L.O. GRAVITY TANKS TO GEARBOX" and was located approximately 4.57 m (15 ft) from the starboard gravity oil tank. The valve was not included in the original approved plans of the piping system and, since it was in addition to the shutoff valves at the tanks, there was no justification for its being in the system. Because a similar condition may exist on other vessels, the following actions must be taken:**
  - (1) During the inspection or reinspection of vessels with gravity-type lubrication, the discharge piping from the gravity tanks must be examined.

## USCG Marine Safety Manual, Vol. II: Materiel Inspection

## SECTION B: DOMESTIC INSPECTION PROGRAMS

## CHAPTER 1: INSPECTION OF VESSELS FOR CERTIFICATION

- (2) If shutoff valves are found in addition to those at the gravity tanks and unnecessary to the system, they must be secured in the open position or removed.

---

**G. INSPECTION AND HYDROSTATIC TESTS OF BOILERS**

---

**TABLE B1-1: TITLE 46 CFR, 61.05-10 – INSPECTION INTERVALS FOR BOILERS  
W/FOONOTES**

**TABLE 61.05-10—INSPECTION INTERVALS FOR BOILERS<sup>123</sup>**

	Firetube boiler ≥150 psi	Watertube boiler	Any firetube boiler for propulsion	Firetube boiler <150 psi
<b>Hydro Test:</b>				
<b>Passenger     Vessel</b>	2.5	2.5	1	2.5
<b>Other Vessel</b>	2.5	5	1	5
<b>Fireside Inspection</b>	1	2.5	1	2.5
<b>Waterside Inspection</b>	1	2.5	1	2.5
<b>Boiler Safety-Valve Test</b>	1	2.5	1	1
<b>Valves Inspection</b>	5	5	5	5
<b>Studs and Bolts Inspection</b>	10	10	10	10
<b>Mountings Inspection</b>	10	10	10	10
<b>Steam Gauge Test</b>	2.5	2.5	2.5	2.5
<b>Fusible Plug Inspection</b>	2.5		2.5	2.5

<sup>1</sup>All intervals are in years.

<sup>2</sup>Where the 2.5-year interval is indicated: two tests or inspections must occur within any five-year period, and no more than three years may elapse between any test or inspection and its immediate predecessor.

<sup>3</sup>Intervals for hybrid boilers are the same as for firetube boilers.

### 1. General

Marine boilers have historically been classed into two general types: firetube (or "tank") boilers and watertube boilers. A new type of marine boiler, called a hybrid boiler, has **since** been approved for auxiliary steam use aboard U.S.-flag vessels. The American Society of Mechanical Engineers (ASME) Manufacturers' Data Report forms must be made available to the Coast Guard marine inspector for review at the time of any boiler installation, per 46 CFR 52.01-145. The marine inspector will inspect each boiler after installation and review the Data Report forms to ensure the boiler complies with Coast Guard regulations. See 46 CFR 52.01-135 and 53.10.

## SECTION B: DOMESTIC INSPECTION PROGRAMS

## CHAPTER 1: INSPECTION OF VESSELS FOR CERTIFICATION

**In addition, low pressure hot water boilers can be encountered on any number of Coast Guard inspected vessels. While they are typically small self contained units with limited safeties and controls, they do present a very real hazard to life and property if not in good repair, with all safeties and controls in working order.**

- a. Firetube boilers. The most common firetube boiler is the "Scotch" type. **Now obsolete in riveted form, they are limited to historic or older vessels propelled by reciprocating engines with very simple boiler feed systems. Some may be coal-fired.** Feed water control is primitive at best and, generally, no provision is made for keeping dissolved oxygen out of the boiler water.

**In modern welded form, fire tube boilers are rarely seen as propulsion boilers except on Western Rivers steamers. They are most commonly installed as auxiliary boilers on ships with diesel propulsion or on barges where heated cargo systems are required.**

- b. Watertube boilers. Watertube boilers are designed for operation under considerably greater stresses than firetube boilers.
- (1) Since the tube **metal temperatures are also** higher, scale deposits that **can be tolerated** in firetube boilers **at lower pressures** are unacceptable in watertube boilers. For these reasons, only distilled water can be used for boiler feed and close regulation of the feed water chemistry is essential to prevent pitting of the boiler metal and to reduce scale deposits to a minimum.
  - (2) Compared to firetube boilers, the pressure-containing parts of **modern, welded** watertube boilers are of simple design, without complicated riveted seams and stayed surfaces. Repair frequency is considerably lower and, when repairs are necessary, they involve **relatively less complicated** operations, **such** as tube renewals, refractory and insulation repairs and renewals, and boiler casing maintenance.
  - (3) **Watertube boilers are also more sensitive to improper operation and inadequate maintenance. Tube temperatures are normally so high that even a thin scale deposit on the tube interior seriously impairs heat transfer which may result in tube failure. Cleanliness of the fireside is equally important to prevent loss of metal from corrosive elements in the fuel used. Economizers and air heaters located in gas passages must be kept free of soot deposits to reduce fire hazard.**
- c. Hybrid boilers. Hybrid boilers incorporate a design feature which combines the concepts of both firetube and watertube boilers. The concept makes efficient use of space and consumes less fuel than a traditional firetube boiler.

## SECTION B: DOMESTIC INSPECTION PROGRAMS

**CHAPTER 1: INSPECTION OF VESSELS FOR CERTIFICATION**

- (1) Hybrid boilers usually burn number 6 fuel oil, but can also burn a variety of other fuels, including heavy oils, sludge, and solid waste with a few additional pieces of equipment.
  - (2) Current designs average about 1.53 m (5 ft) in outside diameter, 3.66 m (12 ft) in height, and consist of upper and lower chambers connected by a tube nest.
  - (3) Certain designs have incorporated engine exhaust gas firing along with in-port oil firing, thus eliminating the need for a ship's exhaust gas economizer. The burner and register unit is mounted at the boiler front on the lower chamber and is exactly the same type of unit that would be found on a traditional firetube boiler. Standard appurtenances such as safety valves, water glasses, feed and stop valves, steam gauges, and blow-off valves are also incorporated in present design features.
  - (4) Current furnace designs consist of horizontal cylindrical or vertical torispherical type configurations. Horizontal types are connected to the boiler shell by full penetration welds. The vertical furnaces are attached to the shell by an ogee ring which can either be integral to the furnace or be an external support flange. The ogee ring must be joined to the furnace by a full penetration weld. The connection of the ogee ring to the boiler shell must either be a full penetration weld if an external support flange, or a fillet weld if an integral type ogee ring. The integral type ogee ring must meet ASME Section I PFT 20.5.
  - (5) Depending upon size, the furnace may be supported by a number of stays that extend from the furnace to the boiler shell. The number of stays used for support depends on the furnace size and the maximum allowable working pressure (MAWP) of the boiler. In some cases, stiffening rings are used to add support to the furnace in lieu of stays.
  - (6) At the apex of the furnace, an exhaust pipe extends from the furnace into the lower boiler tube sheet. This pipe passes the exhaust gas over the steam generating tubes before the gas exits through the flue. Steam generating tubes connect the lower tube sheet to the upper tube sheet. There may also be downcomer tubes installed in the tube nest between the two tube sheets. Within the tube bundle are several stay tubes whose function is to add support to the tube sheets. Above the upper tube sheet, in the upper chamber, is the steam-generating area. The dry pipe is located near the center of the upper head. Future designs may incorporate variations on this basic theme.
- d. **Low Pressure Steam and Hot Water Boilers on Small Passenger Vessels (SPVs):** Field observations indicate there is confusion on the inspection requirements for low pressure packaged boilers. In some cases, they are not being inspected at all when found on SPVs inspected under 46 CFR Subchapters K and T. These units may generate steam or supply hot water. A typical installation operate at

## SECTION B: DOMESTIC INSPECTION PROGRAMS

## CHAPTER 1: INSPECTION OF VESSELS FOR CERTIFICATION

pressures  $\leq 15$  psi for steam, at  $\leq 30$  psi for hot water and are constructed of cast iron materials or operate  $\leq 100$  psi if constructed of wrought iron and are “fired”.

- (1) OCMI's are encouraged to ensure properly qualified MIs are involved in oversight and/or inspection of these units because of the inherent safety risk.
- (2) Requirements are in 46 CFR 119.310 for and 46 CFR 182.310 for small passenger vessels. Applicability of 46 CFR Subchapter F is in Table 54.01-5(a). Regulations indicate there are inspection requirements if boilers are made of wrought iron operated at  $\leq 15$  psi for steam and  $\geq 100$  psi for hot water or have a hot water temperature  $\geq 250$  degrees F. Cast iron boilers operated at  $\leq 30$  psi or  $\geq 250$  degrees F for hot water also have requirements. These are provided in 46 CFR 54.01-10 and 54.01-15.
- (3) 46 CFR 53.01-10(c)(2) indicates oil fired boilers must meet the requirements in 46 CFR Subchapter F, Part 53 regardless of size or heat input. However, it is important to note Subchapter F's applicability for auxiliary and heating boilers on SPVs shall be “*as determined necessary by the OCMI.*” See 46 CFR 119.310(c) and 182.310(c), which also indicates that “*heating boilers must be tested and examined every three years.*” For low pressure packaged boilers, applying Subchapter F in its entirety may not be reasonable or necessary to ensure an appropriate level of safety.

If electrically fired, U.L. approved hot water supply boilers with a capacity  $< 120$  gallons, and a heat input  $\leq 58.6$  KW (200,000 BTU/ HR) are exempt from 46 CFR Part 53. However, this is provided there is a safety/relief valve installed in accordance with 46 CFR 53.01-10(c)(1). Also see Note 4 of 46 CFR Table 54.01-5(a) regarding relief devices.

- (4) Boiler plates require an ASME stamp. If built to ASME Code Section I (Power Boilers) or ASME Code Section IV (Heating Boilers), the plate will be stamped with the “S” or “H” symbol.
- (5) 46 CFR 63.10-1 requires two copies of detailed instructions for operational tests on each “automatic” auxiliary boiler. A certification report detailing compliance with, ASME and 46 CFR Part 63 is also required. All should be submitted to MSC for approval prior to installation or replacement of a unit. OCMI's should retain copies for local record.



**CHAPTER 1: INSPECTION OF VESSELS FOR CERTIFICATION****2. Examination and Testing of Firetube Boilers**

- a. Test and examination intervals. Title 46 CFR Subchapter F, Part 61 requires annual **fireside, waterside and hydrostatic tests** for propulsion firetube boilers. No extension of these requirements is authorized. However, **auxiliary firetube boilers require fireside, waterside and hydrostatic tests less frequently at intervals specified in 46 CFR Table 61.05-10.**
- b. Hydrostatic tests. Firetube boilers are particularly vulnerable to thinning of the plating, tubes, and staybolts (if not welded construction) by corrosion. This is often seen in the form of pitting, attributed to dissolved oxygen or the use of corrosive boiler water.
  - (1) The hydrostatic pressure should be maintained at 1.5 times the MAWP throughout the inspection of the fireside.
  - (2) When boiler repairs are necessary, the methods, materials, and workmanship employed must comply with the requirements of 46 CFR Part 59.
  - (3) In Scotch-type boilers, pitting is commonly found on the outside of the tubes and the shell and head plating near the waterline, the combustion chamber top plating, the furnaces, and the bottom shell plating. If riveted, the numerous highly stressed joints in firetube boilers are prone to attack by stress corrosion cracking, generally resulting from the deposit of corrosive solids contained in the boiler water.
- c. Interior examination. The interior examination of a firetube boiler should occur first and be conducted as follows:
  - (1) The interior of the furnaces and combustion chambers should be examined first. Furnaces should be checked for distortion by measuring with a tram bar. When corrugated or plain furnaces are distorted and no longer in true circular shape, they must be repaired as required by 46 CFR 59.15-1(a) or the boiler pressure must be reduced as required by 46 CFR 59.15-1(c).
  - (2) Combustion chamber wrapper plates and back plates should be hammer tested, and areas suspected of being thin should be drilled and gauged. Broken combustion chamber stays will generally be indicated by leakage from the drilled telltale holes. The combustion chamber back plate should be checked for evidence of bulging plating between the staybolts.
  - (3) Riveted wrapper plate seams and the furnace connection to the combustion chamber should be checked for leakage. The back tube plate should be carefully

**SECTION B: DOMESTIC INSPECTION PROGRAMS****CHAPTER 1: INSPECTION OF VESSELS FOR CERTIFICATION**

examined since leakage in this area, which cannot be corrected by rolling tubes, is sometimes due to cracks in the ligaments between tube holes.

- (4) Tube sheet examination. The front tube sheet should be examined next. This is an area particularly susceptible to corrosion from leaking tubes, and to erosion caused by the use of saturated steam for soot blowing. Leaking tubes should be made tight by rolling, or should be replaced.
- e. Exterior examination. The exterior examination of a firetube boiler should occur as follows:
- (1) The exterior of the boiler shell and heads should be examined first. All lagging of the shell and heads is not normally taken off during annual inspections; however, all portable sections should be removed while the hydrostatic pressure is maintained. Wherever moisture appears, sufficient lagging should be removed to determine its source, whether leaking seams, broken staybolts, or defective boiler mounting gaskets.
  - (2) The plating in way of the boiler mountings should be examined for evidence of wastage due to leaks from valves and fittings. Leakage from the bottom of the front and back heads in way of the flanging of the plate should be noted for further examination of the inside of the head; cracks induced by flexing of the head sometimes penetrate the plating.
  - (3) Riveted seams showing evidence of leakage should be carefully examined; cracks occasionally occur between rivet holes or extend from rivet holes to the plate edge.
  - (4) The manhole gasket seats and adjacent plating should be checked for signs of wastage due to gasket leaks; the radial clearance between the manhole plate and the head should not be excessive.
  - (5) The boiler saddles, foundations, and collision chocks should be hammer tested to detect evidence of deterioration; these members are subject to severe wastage from the corrosive action of bilge water.
  - (6) The hydrostatic pressure should then be released and the boiler drained out.
- f. Examination of the boiler waterside. The inspection of the waterside of the boiler should occur as follows:
- (1) The inspection of the waterside of the boiler is most conveniently begun by entering through the top manhole. The dry pipe, internal feed lines, and surface blow pipe should be examined first; defective gaskets at the point of attachment of the internal feed lines to the boiler head are frequently the source of erosion of the plating.

## SECTION B: DOMESTIC INSPECTION PROGRAMS

## CHAPTER 1: INSPECTION OF VESSELS FOR CERTIFICATION

- (2) **In riveted construction, the** butt strap and the rivets attaching the heads to the shell should be sounded with a hammer. Where rivets are found to be loose or rivet heads missing, the rivet holes should be searched for cracks by nondestructive testing methods after the rivets are removed.
  - (3) **In other than welded construction and when installed, the** stay rods, girder stays, and combustion chamber tops should be examined for evidence of wastage due to corrosion. The screw stays at the back and sides of the combustion chambers are difficult to examine because of close clearances. However, a good evaluation of the condition of these members can be made with the use of a portable electric light lowered successively between the rows of stays. The most common deficiency found in these stays is "necking," a reduction in diameter near the plate surface caused by corrosion and stresses from expansion of the combustion chamber.
  - (4) The boiler tubes are so closely spaced that visual inspection must usually be confined to the top and side rows. Pitting is frequently seen in these tubes. **Shallow**, widely scattered pits can usually be disregarded, but deep pits extending over a large area may so reduce the wall thickness that replacement of tubes is necessary (from the standpoint of stress, tubes will satisfactorily function with a reduction of wall thickness of up to 50 percent). In any event, when evaluating the condition of boiler tubes, a distinction must be made between plain tubes and stay tubes; stay tubes have a much greater initial wall thickness.
- g. Completing the boiler examination. Finally, the lower part of the boiler interior is inspected as follows:
- (1) The most common defects in this area are corrosion of the plating of combustion chambers, furnaces, shell, and heads by pitting, and grooving of the flanged plating of the heads and furnaces.
  - (2) Pitting often attacks the plating of the furnaces, combustion chamber wrapper plates, back plates, and the bottom plating of the boiler shell.
  - (3) Grooving due to thermal stresses is frequently seen in the flanges of the front and back heads, and at the connections of the furnaces to the combustion chambers.
  - (4) Radial grooving, originating in the holes drilled in the front and back heads for the stay rods (when installed) and extending in a "spider web" from these holes, is occasionally encountered.

**CHAPTER 1: INSPECTION OF VESSELS FOR CERTIFICATION****3. Inspection of Watertube Boilers**Test and examination intervals.

- a. Inspection of watertube boilers. Title 46 CFR Subchapter F, Part 61 requires hydrostatic tests for all watertube boilers **every five years (twice in 5 years with no more than 3 years between any test or inspection and its immediate predecessor, in the case of passenger vessels) as specified in 46 CFR Table 61.05-10. Watertube boilers require fireside and waterside inspections twice in 5 years with no more than 3 years between any test or inspection and its immediate predecessor.**

Following repairs and at the conclusion of inspections, watertube boilers should always be hydrostatically tested to a minimum of 1.25 MAWP **per 46 CFR 61.05-10. (If substantial modifications or repairs have been made, or if the marine inspector has reason to question the strength of the boiler, to 1.5 MAWP).**

**Substantial repairs are welding on a header or a drum. Tubes that are welded rather than expanded into headers should be considered substantial repairs. New piping or welded repairs on piping attached to the boiler as well as waterwall or superheater headers newly fabricated and installed would be substantial repairs.**

**Replacing or plugging tubes is not a substantial repair. Boiler tubes that have been replaced should be hydrostatically tested to 1.25 MAWP. Tubes that have been plugged can be hydrostatically tested to operating pressure.**

**Questionable boiler strength would be the existence of widespread pitting, header grooving, a recent history of tube failures or sitting idle for a long period of time. An inspector should have a reasonable level of confidence that the boiler will steam at normal operating pressure without leaking, and questions of boiler integrity should be resolved through testing.**

- b. Interior examinations of watertube boilers. The inspection is most conveniently begun inside the furnace, as follows:

- (1) The waterwall tubes and screen tubes should be examined with the aid of a spotlight for evidence of blistering or distortion. Severely blistered tubes should be renewed. A minor amount of tube distortion is acceptable if the insides of the tubes are clean. If there is evidence of tube leakage at the ends of the waterwall tubes, sufficient refractory should be removed to expose the waterwall headers so that the leakage can be traced to its source.

**SECTION B: DOMESTIC INSPECTION PROGRAMS****CHAPTER 1: INSPECTION OF VESSELS FOR CERTIFICATION**

- (2) The superheater and part of its support structure can generally be seen from inside the furnace. In this area, burned support brackets and badly warped superheater elements are common defects.
  - (3) The baffles above and below the superheater in D-type boilers should be examined. Some boilers of this type are fitted with feeder tubes in the furnace floor, which can be examined only when the brickwork is removed. Defects in these tubes, however, are rarely encountered; the furnace floor should be disturbed only when leakage is suspected or for refractory repairs.
  - (4) Furnace refractory is subject to damage from erosion due to direct flame impingement, fusion occurring at high rates of combustion, and destruction of insulation due to improper drainage during water-washing operations. When the damage is local, the defective area may be repaired; however, it is sometimes necessary to rebuild the walls or floor.
- c. Exterior examinations. The inspector should continue with an exterior examination, as follows:
- (1) The tubes and headers of economizers and gas air heaters are vulnerable to external corrosion due to condensation and should be examined through the access openings.
  - (2) The steam drum and its accessories should be carefully checked; if a hydrostatic pressure test is applied, the nozzles, gaskets, and welded pipe connections should be searched for leakage.
  - (3) In D-type boilers, the sliding feet that permit linear expansion of the water drum should be examined.
  - (4) Expansion of the generating tubes of straight tube boilers is accommodated by bolting the front headers rigidly and securing the back headers with loosely fitted bolts; the condition of these bolts should be checked.
  - (5) In sectional header boilers, the riser tubes, drum nipples, and top row of generating tubes can be reached for examination from the access opening below the steam drum.
  - (6) Removal of the superheater access doors in D-type boilers will permit access to the superheater and the lower part of the steam drum. In both boiler designs, the casing in way of the steam drum should receive attention; gas leakage in this area is common. The casing below the steam drum should be examined; burning or bulging of this casing or distortion of access door frames is usually due to destruction of the insulation. If these conditions are found, the buckled casing must be removed so that the insulation can be replaced.

## SECTION B: DOMESTIC INSPECTION PROGRAMS

## CHAPTER 1: INSPECTION OF VESSELS FOR CERTIFICATION

- d. Header examinations in sectional header boilers. The headers of sectional header boilers should be examined next, as follows:
- (1) Leaking handhold plates should be marked for later removal and renewal of gaskets. The gasket surface should be examined with the aid of a mirror; chronic leakage is sometimes due to steam cuts across the seating surface.
  - (2) The handhold plates of superheater headers should be similarly examined, and the superheater tubes should be checked for leakage where these tubes are rolled in the headers.
  - (3) The short nipple connections of the transverse mud drum to the front headers and the bottom blow valve connection to this header should be checked for leakage; external corrosion of the nipples is sometimes encountered.
  - (4) The tube joints, handhold plates, and drain nipples of the waterwall headers should be checked for evidence of leakage and external corrosion. The air duct beneath the furnace floor should be examined to ensure that it is free from accumulation of oil.
- e. Header examinations in D-type boilers. The superheater headers and waterwall headers of D-type boilers should be examined as follows:
- (1) The vestibule below the economizer or air heater should be opened and cleaned. In this area, the ends of the generating tubes, at the connections to the bottom drum, can be seen. Because of the close spacing of the tubes, inspection is usually limited to the outer rows; however, external corrosion of these tubes, due to soot deposits and improper water-washing, is not uncommon.
  - (2) The bottom drum manhole opening, bottom blow valve connection, and drum support saddles should be examined. In this area, leakage and associated wastage are rarely seen; however, the foundations of boilers installed directly on the tank tops are subject to wastage from the corrosive action of bilge water.
- f. Examinations of the waterside. The waterside should be examined as follows:
- (1) The interior of the steam drum is the best starting point for inspection of the waterside of the boiler.
  - (2) The flanged piping connections of the desuperheater and internal feed lines should be hammer tested; if the tightness of the desuperheater piping is in doubt, it should be hydrostatically tested. **Typical hydrostatic test pressures to test a desuperheater range from 150 to 300 psi. The actual hydrostatic test**

## SECTION B: DOMESTIC INSPECTION PROGRAMS

## CHAPTER 1: INSPECTION OF VESSELS FOR CERTIFICATION

**pressure to be used, of course, must be obtained from the tested boiler technical manual.**

- (3) The steam drum should be thoroughly cleaned prior to inspection; portions of the drum internal platform should be removed to permit a close examination of the drum interior and the tube ends. Pitting along the waterline, in the bottom of the drum, and in the ends of the riser tubes and generating tubes, is occasionally found.
  - (4) The brackets supporting the dry pipe, internal feed lines, and desuperheater should be examined to ensure that the securing bolts are tight.
- g. Examination of tubes.** Tubes should be examined as follows:
- (1) A sufficient number of handhold plates should be removed from the headers of the generating tube bank, superheater, economizer, and waterwall tubes to permit a comprehensive examination of these tubes.
  - (2) In addition to tube inspection, handhold plates should be opened to permit inspection of header baffle plates, orifice plates, drain locators, branch lines, inlet/outlets, elbows, thermometer wells, and other locations subject to high stresses or corrosion.
  - (3) Generally, removal of 5 percent of the handhold plates will suffice; however, if internal pitting or an excessive amount of scale is found, it may be necessary to remove all of the handhold plates for a complete examination.
  - (4) Scale deposits exceeding 1/32" in thickness will seriously impair heat transfer, especially in screen tubes and waterwall tubes, and may result in bulgin and distorted tubes. Scale should be removed by mechanical means or by chemical washing.
  - (5) Examination of tube interiors is difficult in D-type boilers because the tube bends preclude sighting more than a short distance inside each tube. However, the tubes should be inspected from within the lower drum and, with the aid of a mirror, from the waterwall and superheater headers. The inside surface of the bottom drum should be examined for evidence of pitting; this is occasionally seen in boilers that have been out of service for long periods of time.

---

#### **4. Examination of Hybrid Boilers**

- a. Hybrid boilers are very compact in their construction as a result of the design efforts to comply with size restrictions imposed by ship builders. They are considered to be

## SECTION B: DOMESTIC INSPECTION PROGRAMS

## CHAPTER 1: INSPECTION OF VESSELS FOR CERTIFICATION

auxiliary heating boilers, and their operating controls are regulated under 46 CFR 63, depending upon fuel consumption and rated heat output.

- b. Tests. For test purposes, these boilers are considered to be of the firetube type and must be hydrostatically tested at least annually, per 46 CFR 61.05-10.
- c. Fireside and waterside examinations. The limited access available for internal examinations of these boilers presents some unique inspection problems. Methods available to perform internal examinations are few and certain areas of these hybrid designs demand special attention by the marine inspector.
  - (1) The tube sheet ligaments, if accessible, should be thoroughly examined for cracks, especially near the furnace area. To the extent possible, the tube sheets should be examined for distortion or other indications of surface deterioration.
  - (2) Uptake/flue pipe between the top of the furnace and the lower tube sheet should be examined for possible yielding of the material caused by excessive heat either from normal firing with a low water level or extreme high firing rates for extended periods of time. The external pressure exerted on a horizontal cylindrical furnace or an uptake pipe will eventually cause the pipe to fail after being subjected to these conditions.
  - (3) The fireside of the furnace should be examined for brickwork damage or deterioration.
  - (4) All accessible waterside areas of the furnace should be examined for signs of pitting, cracks, and scale. A serious scale build-up or pitting on the furnace plate's waterside can be indicative of a poor boiler water treatment program.
  - (5) During the waterside exam, the furnace and shell surfaces in the vicinity of the ogee ring (and the ring itself) should be thoroughly examined. This area supports a majority of the load and is susceptible to very high stresses. If evidence of deterioration or distortion is found, nondestructive testing should be performed on the welds, which connect the ogee ring to the shell, and to the furnace. Any problem involving the ogee ring should be investigated from both the internal and external vantages, on the ring's inner and outer diameters.
- d. Stays. Boiler stays should be carefully examined for cracks, especially in way of the welds. Stays should be examined to detect "necking" or similar evidence of deterioration.
  - (1) One method to evaluate the condition of a boiler stay is to strike it with a hammer and listen carefully to the resulting sound. Generally, if the stay is in good condition, it will make a ringing sound when struck. A dull sound is indicative of a cracked or otherwise deteriorated stay and; a stay that produces a dull sound upon testing should be thoroughly inspected for defects.



## SECTION B: DOMESTIC INSPECTION PROGRAMS

## CHAPTER 1: INSPECTION OF VESSELS FOR CERTIFICATION

- (2) Other forms of nondestructive testing, such as dye-penetrant or magnetic particle, can be used to determine a stay's condition. When several stays in one area are found to be defective, the problem is nearly always due to uneven loading on the support structure, a condition that should receive immediate corrective action.

---

## 5. Examination of Low Pressure Steam and Hot Water Boilers on SPVs

- a. **Fireside/Waterside (Internal) Exams:** These are prescribed in 46 CFR 61.05-10(a) and the Table to 61.05-10. In order to fully comply with 46 CFR Subchapter F, the removal of the discharge or outlet valve and the safety/relief valve will be required. This will provide sufficient access to the waterside and allows MIs to identify the presence of scale or rust accumulation on internal components. If the internal condition of the heating element is suspect, additional action would be required to assess the condition of the boiler. Removing the burner assembly for a visual exam of the furnace should generally satisfy the requirements for a fireside exam. If the condition of the heating element or refractory is suspect, removal of the first section of the unit's stack casing should provide enough access to determine if further action is necessary.

Enforcing the internal exam requirements on automatic low pressure packaged heating boilers, although applicable, is problematic on SPVs. The waterside has limited access through boiler drains, outlets and safety/relief valves. The fireside exam, although more accessible, may not be necessary if the unit was examined by an accepted third party and found satisfactory. More importantly, a SPV operator's experience may be limited for disassembly and proper re-assembly of these units. Conducting such work may cause more harm than good.

To address the lack of operator experience, some OCMI's have a local policy which ensures untrained operators do not disassemble these units, conduct internal exams or hydro tests. In lieu, they allow an acceptable third party (e.g. state licensed boiler service provider or manufacturer certified technician) to perform "servicing" of boilers. Servicing should be completed every 3 years or more often if recommended by the manufacturer. When the OCMI accepts a service report in lieu of inspection, MIs should require removal of the burner assembly for a cursory furnace exam. This should be followed by a subsequent external visual exam while the unit is operating.

- b. **Hydrostatic Tests:** 46 CFR 61.05-10(c) indicates that a boiler hydro should be completed at 1.5 times MAWP if the findings from a visual exam of the heating element identifies a suspect condition. A hydro at 1.25 times MAWP may also be required at regular intervals if the OCMI deems it necessary to meet 46 CFR Subchapter F. Hydro water temperature should range between 70 and 100

## SECTION B: DOMESTIC INSPECTION PROGRAMS

## CHAPTER 1: INSPECTION OF VESSELS FOR CERTIFICATION

degrees °F in accordance with 46 CFR 61.05-5(b). The hydro pressure should be held for 10 minutes and should remain constant.

- c. **Safety/Relief Valves:** Tests should be completed per 46 CFR 61.05-10 with the valves in-service or they can be removed and bench tested. Hand lifting gear should be exercised when the boiler is in-service. Caution should be taken when exercising hand lifting gear due to the discharge of steam/hot water. All safety/relief valves must have an ASME “H” or “HV” stamp in accordance with 46 CFR 52.01-2. The discharge should be per 46 CFR 56.50-25(c).

If the unit is a hot water boiler, it requires a combination pressure/temperature relieving device in accordance with 46 CFR 53.05-2(c). Some OCMI policies allow valves to be visually examined and ‘popped’ while in service. This is typically done during annual inspections. MIs should be aware that this test method only ensures the pressure functionality of the valve. To ensure safety, these valves should be properly tested for temperature and/or pressure accuracy by the accepted third party to satisfy regulation. This test is normally required every 3 years as implied in 46 CFR 119.310(c) and 182.310(c).

- d. **Boiler Mountings:** Mounting inspections on low pressure boilers include the water inlet/outlet valves and the safety/relief valve. However, any valves installed as the first valve isolating boiler pressure also need to be inspected. Mounting inspections are required every 5 years and removal every 10 years in accordance with 46 CFR Table 61.05-10 and Marine Safety Manual Volume II, COMDTINST 16000.7 (series). Boiler valves must meet ANSI Standard Class 150 or higher, be constructed of acceptable material as specified in 46 CFR 56.60 and be marked in accordance with 46 CFR 56.20-5. Bolts, studs and nuts may be in the low strength bolting category defined by ANSI B16.5(a).

(1) If the unit is low pressure *steam*, mounting inspections are recommended in accordance with 46 CFR Table 61.05-10 because of the increased risk and obvious personnel safety hazard.

(2) If the unit is low pressure *hot water* boilers, the risk is less Enforcing mounting requirements may be unnecessary if there is routine servicing which includes valve inspection by an accepted third party or if all piping connections are threaded, making mountings removed/studs examined not applicable. The scope of mounting inspection on a *hot water* boiler should be at the discretion of the attending MI for cause.

- e. **Automatic Controls:** Low pressure steam or hot water boilers are required to have automatic controls. If a unit is deficient in this area, it should be taken out of service until the OCMI determines appropriate compliance to 46 CFR Subchapter F. 46 CFR 63.10-1 requires a boiler manufacturer to list each control and safety device prior to installation. This should be accompanied with

## SECTION B: DOMESTIC INSPECTION PROGRAMS

## CHAPTER 1: INSPECTION OF VESSELS FOR CERTIFICATION

a description of the operational tests to be performed and a certification report. The test procedures and certification report should be used as a guide for checking safety shutdowns and controls as prescribed in 46 CFR 61.35.

- f. **Documentation:** These units are pressure vessels, so should be listed on the vessel's COI and entered into MISLE to ensure regular inspection. OCMI's should vet third party service providers, either by observation or other practical means, prior to accepting their reports in lieu of inspection. Experience, certification and training are all methods an OCMI should consider. It is also recommended that OCMI's identify accepted third party service providers in writing so a record is made. Periodic review of service providers work and/or credentials should also be considered.

Retention of equipment specifications and model numbers is highly recommended to ensure that proper servicing, repair and documentation of the installation takes place.

## 6. Repairs to Boilers

- a. It is difficult to describe all of the types of boiler repair procedures that the inspector may have to consider.
- (1) Boiler defects will seldom involve only certain specific areas. Severely pitted tubes will often be accompanied by pitting in headers or in steam and water drums. Similarly, a distorted corrugated furnace frequently is evidence of wastage of combustion chamber plates or adjoining furnaces.
  - (2) All repairs must comply with the requirements of 46 CFR Part 59.
- b. **Firetube boilers.** In firetube boilers, close tube spacing limits visual inspection of the outside of the tubes is limited to the outer rows. Heavy scale buildup on these tubes is common, and thorough cleaning of the tubes **may necessitate** chemical cleaning. **(See figure B1-2 for examples of defect and repairs to fire tube boilers.)**
- (1) In addition to pitting on the waterside, these tubes are subject to wastage of that part of the tube that projects beyond the tube sheet, particularly in the smoke box area. This condition is easily detected. When it is found, the defective tubes should be renewed.
  - (2) On the other hand, thinning of the tube walls due to corrosion can usually be discovered only by cutting out and sectioning tubes. This procedure should be followed only when a substantial number of the tubes are found to be leaking or plugged. In general, when tubes look satisfactory on the waterside, the boiler has no history of tube failure, and leakage can be corrected by rerolling, the tubes

**CHAPTER 1: INSPECTION OF VESSELS FOR CERTIFICATION**

may be kept in service. Tubes from which the beading has been burned off should not be built up by welding, but must be renewed.

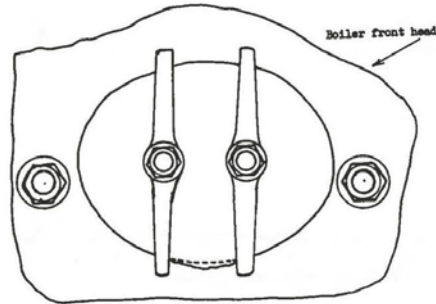
**Figure B1-2: Examples of Defect and Repairs to Fire Tube Boilers****Wastage of Scotch Boiler Front Head Below Manhole Opening**

Repair consists of thorough cleaning or grinding to sound metal, magnetic particle testing to ensure no fractures exist and building up of original thickness by welding.

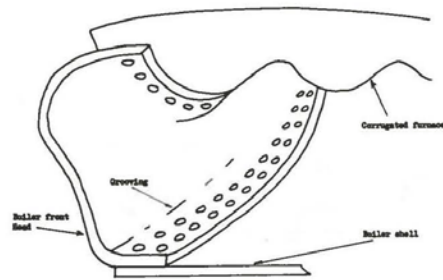
**Grooving of Front Head Below Furnace**

Grooving in this area, when it is not extensive, may be repaired by chipping out the groove to sound metal, non-destructive testing and subsequent welding. Extensive grooving, or fractures stemming from old grooving previously welded can be repaired only by cutting gout and renewing a portion of the head plating.

## SECTION B: DOMESTIC INSPECTION PROGRAMS

## CHAPTER 1: INSPECTION OF VESSELS FOR CERTIFICATION

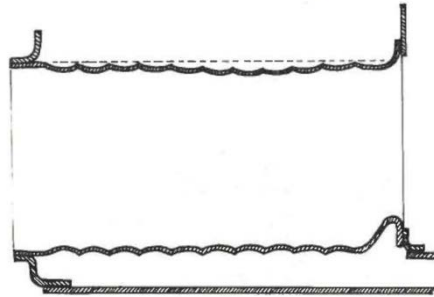
**Distorted Corrugated Furnace****Repair in conformity with procedure outlined in 46 CDR 59.15-1**

- c. Watertube boilers. In watertube boilers, tube replacement is one of the most frequently encountered repair procedures. Boiler tube life is influenced by such factors as original wall thickness, thermal stresses due to location within the boiler, waterside corrosion, fireside damage, and service history of the boiler. The external surfaces of tubes are exposed to loss of metal from corrosion by sulfur and vanadium in the oil burned, as well as overheating and slag damage. Deterioration of this type may result in abnormal bends, bulges, blisters, ruptures, and mechanical fatigue cracks that are fairly obvious during visual inspection of the firesides. The following procedures are recommended for inspection of boiler tubes:
- (1) Conduct a visual inspection of all uncovered tubes.
    - (a) In general, when tubes look satisfactory from a visual inspection, they may be kept in service until some degree of failure is encountered.
    - (b) When the same type of tube failure occurs often, a major tube replacement should be considered. A number of failed tubes may be plugged in an operating boiler, generally not exceeding 10 percent of the tubes in any one tube bank, section, or pass. However, this 10 percent figure is for guidance purposes only, and any recommendations for tube replacement by the manufacturer's representative should be followed.
    - (c) Tube location is important in determining whether the tubes can be plugged. Superheater tube plugging should be limited to 10 percent of each pass. Renewal of tubes at less than 10 percent may be justified if the tubes in question are in a group or may cause poor gas flow or overheating. Defective support tubes should be renewed. Defective major circulating tubes, such as downcomer or riser tubes, should be replaced.

## SECTION B: DOMESTIC INSPECTION PROGRAMS

## CHAPTER 1: INSPECTION OF VESSELS FOR CERTIFICATION

- (2) If there is a suspicion that deep corrosion produced scabs exist in waterside pits, or if any other condition prevents minimum thickness determination, chemical cleaning to bare metal should be required.
- (a) If this process shows pits in a large number of tubes, and more than one or two in many tubes, a sample tube should be cut out of the boiler and sectioned and its minimum thickness determined.
- (b) If the sample tube has deteriorated generally to less than 50 percent of the original thickness, a representative number of tubes (20-30) should be cut out of the tube bank and the process repeated.
- (c) If more than half of the sample tubes are found to be in the same general condition of deterioration, consideration should be given to retubing the boiler.
- 

## 7. Inspection of Boiler Mountings

- a. Inspection of boiler mountings. The regulations concerning boiler mountings in 46 CFR 52.01-3 and 61.05-15 were written when more attachments were connected directly to the steam drum or boiler shell than in today's more modern boilers, which have welded mountings. However, the intent and concerns of these regulations apply to modern boilers regardless of mounting types.
- (1) The inspector should recognize the importance of all connections and piping to the first isolation valve. It should not be necessary to require removal of all first isolation valves to comply with the "mounting" inspection intent. All major valves, which are the first isolation or control of steam or feedwater, should be treated as "mountings" for inspection of the valve and piping toward the boiler.
- (2) At a minimum, the following valves are subject to valve and mounting inspection requirements: main steam stop, generator steam stop, auxiliary steam stop, main and auxiliary feed stop, blowdown (surface and bottom), superheater vent, superheater drain, and soot blower stop.
- b. Inspection criteria. The following inspection criteria must be observed during inspections of boiler mountings:
- (1) 5-year valve inspection. This should be adequate to ascertain the condition of the valve body, adjacent piping, and valve condition to ensure isolation of the system down from the valve.
- (2) 10-year mounting survey. This includes studs that are subject to high heat and stresses. Valves should be required to be removed if internal piping and valve

## SECTION B: DOMESTIC INSPECTION PROGRAMS

## CHAPTER 1: INSPECTION OF VESSELS FOR CERTIFICATION

conditions cannot be adequately examined from inside the steam drum or other open connections.

- (3) Studs. Boiler mounting studs must be manufactured in accordance with ASME Standard 193. Studs are heat treated and marked on one end with a grade and manufacturer's symbol. A common stud grade is "B7," which indicates a heat-treated, austenitic steel alloy for "high strength" bolting materials.
- (a) Studs should be checked for proper heat number. The stud may be examined in place. If the stud is removed, it should be examined for cracks, "necking" down, or deterioration.
- (b) If studs are bend tested, experience and sound judgment is necessary to determine whether the studs are brittle. Even a new stud will break at the notch of a thread when bent more than 30 degrees. Therefore, bend testing is not recommended.
- (4) Flanged valves. When flanged valves are removed from the boiler pads for any reason, the condition of the studs or bolts that connect the valves to the pads must be determined.
- (a) When valves are bolted to pads or spools that are riveted or welded to the boiler, the riveted or welded joints should not be broken unless there is evidence of leakage or deterioration. These examinations may also be made at intermediate periods if there is any evidence that defects have developed or that excessive corrosion has occurred.
- (b) When one or more flanged joints intervene between a stop valve and the boiler drum or superheater outlet, such flanged joints need not be opened at the time the valve is removed from its flanged joint. An inspector may open a flanged joint at any time if the inspector considers examination to be necessary.
- c. Removal of mountings and attachments on high-pressure boilers. The requirement to remove boiler mountings at 10-year intervals has been modified for certain vessels with unusually high steam pressures. This modification has been permitted due to the difficulty of attaining a steamtight joint and the fact that some valves are welded directly to the steam piping.
- (1) For these vessels, only the bonnets of the valves need be removed to permit the inspection required at 10-year intervals. Valves, mountings, and attachments need not be removed unless defects are found that require their removal for further examination, repair, or replacement.

## SECTION B: DOMESTIC INSPECTION PROGRAMS

## CHAPTER 1: INSPECTION OF VESSELS FOR CERTIFICATION

- (2) Credit must be given for an **10-year** boiler mounting inspection for these vessels if the boiler valve bonnets are opened and the inspector is satisfied with the examination.
  - (3) A mirror must be used to check all inaccessible parts of the mountings.
  - (4) A record of the inspection of the mountings must be made on Inspection Book, **checklist** and a notation made on the COI. This notation must be carried on each succeeding certificate until the next inspection.
- d. **Boiler safety valves. Testing of boiler safety valves is typically conducted at the inspection for certification. Extensions are not authorized for the testing of safety valves. In most cases, the testing of these devices can be accomplished without taking the vessel out of service. Proving satisfactory operation of boiler safety valves is now especially important given the potentially increased intervals between boiler internal examinations and hydrostatic tests. The inspector shall observe the lifting and reseating pressures of the boiler safety valves and examine the valves to determine if there are any signs of weakness or malfunctioning. Whenever evidence of leakage appears, the inspector may require the safety valves to be opened at intermediate periods for examination. The inspector shall carefully check the setting of each boiler drum and superheater safety valve and require any adjustments necessary to maintain the boiler within MAWP.**
- (1) **The inspector shall observe that boiler safety valves are installed correctly and operate satisfactorily. These valves shall be tested to determine if they can prevent the build-up of excessive pressure. Verification of the safety valve settings shall be checked at each inspection and adjusted if necessary.<sup>2</sup> Guidance on in service setting of safety valves is in NVIC 1-71 Para. 5.c. and 5.d., ASME Section 1 PG-72.3 and Marine Safety Manual, Volume IV – Technical, COMDTINST M16000.9 (series) are applicable.**
  - (2) **Inspection of piping. The safety valve escape piping shall be examined for freedom of expansion and proper drainage. At the time the safety valves are tested, the inspector shall also ascertain that the drain opening in the valve body and the escape piping are free. Improper drainage or plugged drains may result in serious corrosion of the valve body and internal parts. The inspector shall examine the boiler casings to ascertain that there is no accumulation of soot, ash, or scale that may drop into the escape piping and cause malfunctioning of the safety valve. The inspector may require the discharge connections to be removed to determine the freedom of discharge from the safety valves.**



## USCG Marine Safety Manual, Vol. II: Materiel Inspection

## SECTION B: DOMESTIC INSPECTION PROGRAMS

## CHAPTER 1: INSPECTION OF VESSELS FOR CERTIFICATION

**<sup>2</sup>NOTE: ABS Rules allow safety valves to exceed the boiler MAWP. This should not be allowed in accordance with 46 CFR 52.01-120(a)(6).**

- e. Cast-iron valves, water columns, test clocks, and gauges. The inspector must carefully examine water columns and gauge glasses at each annual inspection.

**SECTION B: DOMESTIC INSPECTION PROGRAMS****CHAPTER 1: INSPECTION OF VESSELS FOR CERTIFICATION**

- (1) The inspector must ascertain that water cannot accumulate in the pipe forming the steam connection to the water column. The connections to the boiler should be free, as indicated by the action of the water in the glass.
- (2) The water columns and gauge glasses must be blown down on each boiler to determine the freedom of the connections to the boiler and to see that the blow off piping from the water columns and gauge glasses is free.
- (3) The operating condition of the gauge cocks must be determined by test.
- (4) All steam gauges on the boilers and main steam lines must be checked for accuracy.

---

**8. Inspection Procedures for Externally Fired Lap Seam Boilers**

- a. Before inspections. Before inspection, all lagging or other material covering longitudinal lap joints must be removed on the entire length of the seam to a width of at least 4 inches from the nearest course of rivets, after which the seam must be thoroughly scaled and wire brushed outside (and inside if possible).
  - (1) All deposits of electric welding, whether on rivets or plates, must be entirely removed.
  - (2) The joints must then be thoroughly examined for indications of grooving or other defects.
    - (a) Grooving in the initial stages is characterized by a line of irregular surface cracks extending along the caulking edges or running parallel with the line of rivets, and is particularly noticeable on the waterside.
    - (b) When grooving is evident, steps should be taken to ascertain its depth and extent so that a lower working pressure may be calculated, based on the premise that the groove exceeds the maximum measurable depth by 10 percent.
- b. During inspections. During inspection, and while the boilers are under full hydrostatic stress, the exposed seams must be shock tested over their entire length by striking the plates in the vicinity of the rivets with a smooth-headed hammer weighing at least 7 pounds. Should this procedure reveal a leak, however slight, in the solid plate, it means there is a crack. In this case, the lap seam must be cut away and butt straps installed or the shell plate renewed.

## SECTION B: DOMESTIC INSPECTION PROGRAMS

## CHAPTER 1: INSPECTION OF VESSELS FOR CERTIFICATION

- c. Fusion welding. Fusion welding for any purpose or to any degree must not be applied or allowed to remain on rivets or solid plate forming a longitudinal lap joint. Should leaks develop as a result of slack seams or rivets, a sufficient number of rivets must be renewed in order to obtain a tightly caulked joint.
- (1) Rivet removals, when necessary, should be accomplished by chipping off the rivet points (heads) and driving out the shank, but never by burning.
  - (2) In every case where rivets are removed, appropriate nondestructive testing should be used to detect the presence of cracks. Seams found to be satisfactory may be relagged or otherwise covered so that the covering can be easily removed intact at subsequent inspections.
- d. Reports of defective seams. Commandant (CG-CVC) must be provided with a detailed report, including photographs, if obtainable, in each case where defective seams are detected.
- e. Alternative repair methods. Should a departure from these methods of repair become necessary, full details must be transmitted to Commandant (CG-CVC) for approval before alternative action is taken. A separate entry must be made on Inspection Checklist, CG-840 in each such case, indicating that the foregoing procedures have been carried out. A statement of the conditions found and the nature and extent of repairs, if any, must be included.
- 

## 9. Lessons Learned About Boiler Operation

- a. Explosions in firetube boilers. Facts discovered during the CAPT C. MATHIASSEN investigation indicated that a weakened condition of the flanged plate, forming part of the combustion chamber, escaped detection during the annual inspection.
- b. It is evident that hydrostatic and hammer tests alone are not sufficient to establish the integrity of a boiler for continued service. Defects that show up under hydrostatic tests can easily be observed from the outside or fireside of conventional boilers. Often, however, the most serious defects are indicated only by the surface condition of the plates or other parts seen from the waterside or steamside. Some of these interior defects are:
- (1) Grooving, which is usually found along the edge of lapped plates and **fatigue cracking on the knuckles of flanged plates** and on the underside of the first corrugation forming the horse collar of Morison-type furnaces; and
  - (2) General deterioration of plates and stays caused by corrosion, which is often concealed by a thick layer of scale.

## SECTION B: DOMESTIC INSPECTION PROGRAMS

## CHAPTER 1: INSPECTION OF VESSELS FOR CERTIFICATION

- (3) **The extent to which these defects have advanced can be determined only through most careful examination after the boiler has been thoroughly scaled and cleaned.**
- 

**10. Superheater Erosion**

- a. Inspection procedures. When inspecting boilers that have superheater headers installed vertically or nearly vertically, the inspector must use all means available to determine if there is grooving or pitting of the header in the area of the baffle. This examination should include the use of mirrors and finger touch, as necessary.
- (1) If serious pitting or erosion is found in such superheater headers, the drain holes should be relocated in the baffle near the center thereof and the original holes welded closed.
  - (2) Whenever pitting or erosion is noted, necessary repairs should be made to prevent a potential boiler casualty.
- b. Cast-iron and malleable iron valves. Failures of cast-iron boiler valves used in main and auxiliary steam feed and blow off lines installed prior to 1 July 1935 have resulted in a number of serious casualties and deaths.
- (1) Because of the thinning down of the valve bodies due to corrosion and wear, with a consequent decrease in the factor of safety, cast-iron valves and fittings used in boiler mountings and in steam feed and blow off lines should be subjected to thorough examination, particularly at the time of the annual inspection. Since the brittle properties of cast iron may produce fractures under conditions of shock and sudden applications of load, such as "water hammer" and rapid changes in temperature, cast-iron valves and fittings should be carefully and thoroughly examined for cracks and corrosion defects at the time of inspection.
  - (2) At the end of the 5-year period when boiler mountings are opened and the end of the 10-year period when they are removed, in accordance with 46 CFR 61.05-15, cast-iron valves and fittings should be subjected to a thorough visual inspection, both internally and externally.
    - (a) The valve bodies should be inspected to ascertain whether there has been a reduction in wall thickness below the requirements specified in 46 CFR 56.60-10. If the thickness of the material has fallen below the specifications, such valves and fittings should be removed from service.

## SECTION B: DOMESTIC INSPECTION PROGRAMS

## CHAPTER 1: INSPECTION OF VESSELS FOR CERTIFICATION

- (b) Special consideration should be given to installations in which cast-iron valves and fittings have been repaired or have had parts replaced or altered. The bodies of cast-iron valves and fittings should not be tapped for drainage or bypass connections, etc., except when a boss has been cast integral with the valve.
  - (c) Because cast iron and Grade B malleable iron have somewhat similar properties, valves of this latter material should receive the same thorough inspection as required for cast iron.
- c. Steam piping to soot blowers. In one reported casualty, a 600 psi steam supply line to the soot blower elements ruptured, causing serious injuries to the person who was blowing tubes. Examination of the ruptured pipe showed that the rupture occurred in a bend where erosion had, over a period of years, virtually eaten away the pipe from the inside. During periodic inspections, particular attention must be given to areas where erosion or corrosion is likely to occur in soot blower piping. The location of these areas can best be determined from a visual examination of the piping installations aboard the vessel.

---

## H. INSPECTION OF AUXILIARY MACHINERY AND EQUIPMENT

The purpose of tests and examination of auxiliary equipment is the same as for main equipment. Inspectors need to ensure that auxiliary equipment will operate safely at the design pressure, temperature and condition for a specified minimum period of time.

---

### 1. Turbine Driven and Diesel Driven Auxiliary Machinery

- a. **Overspeed trips, low-lube oil pressure trips, and low-lube oil pressure alarms on turbines or diesel driven auxiliary generators should be tested at each inspection. Any operational tests of lube oil shutdown controls should not risk shutting off the oil supply to bearings. Other turbine driven auxiliary machinery, such as 'steam' driven feedwater pumps and fire pumps, require examination under operating conditions. This is to ensure proper functioning of the local and remote startups as well as shutdown and speed controls while under various load conditions.**

---

### 2. Steam Driven Feedwater Pumps

- a. **A manufacturer of feedwater pumps, Coffin, issued a letter in the 1980's recommending against operational tests of the overspeed shutdowns because it introduces conditions which may result in damage to the water end of the pump. Coffin suggested an alternative, which was to send the O/S tripping mechanism to their repair facility in conjunction with the five year ABS survey of the pump. To**

## SECTION B: DOMESTIC INSPECTION PROGRAMS

## CHAPTER 1: INSPECTION OF VESSELS FOR CERTIFICATION

verify the conditions of the pumps, Coffin checks the overspeed mechanism by measuring the tension of the spring and accuracy of the weight on the trip then issues a letter certifying that the pump will trip at the required speed. However, this is only done upon the request of the operator.

b. The overspeed shutdown on a steam driven feedwater pump is a safety device and its proper operation needs to be confirmed. Depending on the feedwater system type, a minimum number of operable feedwater pumps are required and should be tested each inspection in accordance with 46 CFR 56.50-30. Duplication of these pumps is required so that the loss of one feedwater pump doesn't cause the loss of water being fed to the boilers. Loss of feedwater to the boilers due to pump failures results in a loss of propulsion casualty because there is no means to generate steam. There are several options to verify the proper operation of overspeed controls on steam driven feedwater pumps. Regardless of the test method marine inspectors should give operators pre-inspection notification of the intent to test these pumps. The identified test methods are:

- (1) At a minimum, the manual or 'hand' trip on the pump should be tested annually. This test will verify the functionality of the overspeed linkage and steam shutoff valve. However, this test does not verify the overspeed mechanism is set to the proper tripping point. This test should be done with the pump running. If the manual trip does not work, then the entire overspeed mechanism needs to be restored to an operational condition or replaced prior to the ship's departure.
- (2) Another options is for the ship's crew to operationally test the pump overspeed trip. This requires the crew to be knowledgeable with the procedure for testing the trip. A turbine shaft extension must be installed to the pump's turbine to accommodate a tachometer. If the shaft extension is not available or if the crew is not familiar with its necessity, the inspector should consider another method of testing. In addition, the crew must have the overspeed tripping RPM for the pump available. This is typically found in the pump manufacturer's manual.
- (3) If the marine inspector is not satisfied with the crew's capabilities, arrangements can be made for a manufacturer's technical representative to attend the vessel and test the pumps. Some pump manufacturers prefer this over the crew testing the shutdown to avoid turbine casualties.
- (4) As previously mentioned, the manufacturer can also certify the tripping mechanism's spring is set to overspeed at the proper tripping RPM. This typically requires bench testing of the spring and can cause lengthy delays due to removal of the tripping mechanism from the ship. Having the manufacturer certify the tripping mechanism may be the safest method of ensuring the proper operation of the safety device.

**SECTION B: DOMESTIC INSPECTION PROGRAMS**

**CHAPTER 1: INSPECTION OF VESSELS FOR CERTIFICATION**

**NOTE: Not all feedwater or fire pumps are steam driven. If pumps are electrically driven they require no overspeed testing. If the crew is unfamiliar with 'steam' driven feedwater pump testing, consultation with the pump manufacturer should be considered due to potential safety hazards that can result in failed turbine casings and turbine blade debris.**

---

**3. Other Vital Steam Auxiliaries**

- a. **The marine inspector shall determine the following pumps are operable and are provided in duplicate prior to sailing. The Vessel/Facility Inspection Requirements, Form CG-835 shall be written for inoperable or lack of duplication of the following pumps because they are necessary to prevent loss of power casualties;**

- (1) Boiler Feedwater Pumps; 46 CFR 56.50-30(a)**
- (2) Condensate Pumps; 56.50-35**
- (3) Fuel Oil Service and Transfer Pumps; 56.50-65(b)**
- (4) Lube Oil Service Pumps; 56.50-80(b)**
- (5) Main Seawater Pumps (for condenser cooling); 56.50-45(a).**

---

**4. Steering Gear**

See MSM Volume II, Material Inspection, COMDTINST M16000.7 (series), Chapter C4 for guidance on inspections of steering gear.

---

## SECTION B: DOMESTIC INSPECTION PROGRAMS

## CHAPTER 1: INSPECTION OF VESSELS FOR CERTIFICATION

**I. INSPECTION OF PIPING SYSTEMS**

---

**1. General Considerations**

The inspector should be generally guided by 46 CFR Subchapter F and ANSI B31.1 for the inspection of piping systems. The inspector should pay particular attention to material type and rating, pipe securing arrangements, couplings, and alignment. The material and equipment must be suitable for the service intended and meet melting point, ductility, strength, and compatibility requirements for the system. Piping must be well secured to reduce vibration and stresses. Couplings must be suitable for the pressure and service. Proper alignment of piping systems should also be checked. See MSM Volume II, Material Inspection, COMDTINST M16000.7 (series), Chapters B3 and C2 for information regarding expansion joint and dresser coupling requirements.

---

**2. Test and Examination Intervals**

The hydrostatic test interval for firetube boilers' main steam piping must be in accordance with the intervals permitted in Paragraph G.2 of this Chapter. The hydrostatic test interval for watertube boilers' main steam piping must be in accordance with the intervals permitted in G.3 of this chapter. Hydrostatic testing of steam piping subject to main boiler pressure, other than main steam piping **with a nominal size of more than 3 inches should be subjected to a hydrostatic test at a pressure of 1 ¼ times the maximum allowable working pressure of the boiler after every five years of service.**

---

**3. Pressure Relieving Devices**

**The marine inspector shall observe that pressure relieving devices operate satisfactorily. Verification of proper installation for the intended service is a necessary safety precaution. Recent field observations indicated that some relief valves were removed and blanked off when systems required them. Often relief valves are removed after they fail and no suitable replacement is available while vessels are underway.**

**Field observations also indicate that some vapor relief valves have been installed on liquid piping (or liquid relief valves installed on vapor piping) which is a safety concern. Marine inspectors can verify if valves are installed for proper service, whether liquid or vapor, by checking ship-piping diagrams. Liquid relief valves generally have the spring enclosed and do not have lifting gear. Liquid valves also have a cap on the top and the pressure adjusting nut is under the cap. Marine inspectors can also verify the relief valves by checking their nametags.**



## SECTION B: DOMESTIC INSPECTION PROGRAMS

## CHAPTER 1: INSPECTION OF VESSELS FOR CERTIFICATION

Marine inspectors should observe bench or operational testing with a calibrated pressure gauge to ensure pressure relief devices open at proper pressure. Details on testing and setting relief valves can be found in Marine Safety Manual, Volume IV-Technical, COMSINST M16000.9 (series), Chapter 3. Relief valves should be installed where the ship's equipment manuals and piping diagrams indicate. The following are systems/equipment that marine inspectors should verify against ship's equipment manuals;

- a. Low pressure side of reducing stations,<sup>1</sup> 46 CFR 56.07-10(b)
- b. Unfired pressure vessels,<sup>2</sup> 46 CFR 61.10-5 (i)(1) and (2)
- c. All evaporators and heat exchangers, 46 CFR 54.15-15
- d. Discharge side of all fuel oil service pumps, 46 CFR 56.50-65(c)
- e. Liquefied petroleum gases for cooking and heating, 46 CFR 58.16-15 and 58.16-16
- f. Refrigeration machinery, 46 CFR 58.20-10 and 58.20-20

<sup>1</sup>NOTE: Reducing stations should also have pressure gauges on the low pressure side in accordance with 46 CFR 56.50-10.

<sup>2</sup>NOTE: Relief valves are required on Direct Contact (DC) heaters and de-aerating (DA) tanks on steam or feedwater systems. These and all other inspected pressure vessels should be indicated on the vessel's Certificate of Inspection in accordance with 46 CFR 61.10-5.

---

#### 4. Internal Bilge Suction Valves

- a. Internal valves are required to be installed on bilge suction lines on passenger vessels by 46 CFR 56.50-50. They are not required on cargo or tank vessels, but are fitted, in many instances, as an additional safety measure.
  - (1) These valves often consist of screw-down valves that, in many instances, become frozen in the open position. In some collisions and groundings, damage to the vessels could have been greatly reduced if the proper precautions and maintenance had been taken with internal valves. Often, the initial damage was confined to one watertight compartment but because internal valves had been left open, other compartments were flooded, cargo holds were damaged, and personnel were endangered.
  - (2) In the course of some investigations, it was reported that no officers knew the purpose of the valves, or even that they existed.
  - (3) The inspector must check such valves and require them to be operable, whether or not the valves are required under 46 CFR 56.50-50. The inspector must also ensure that the ship's officers understand the purpose of these valves.

## SECTION B: DOMESTIC INSPECTION PROGRAMS

## CHAPTER 1: INSPECTION OF VESSELS FOR CERTIFICATION

- b. **Neutralizing valves or incapacitating remotely operated valves.** Should the operator of a cargo vessel equipped with remote control suction valves in bilge suction lines wish to remove these valves or render them permanently inoperable in the open position, the following are examples of acceptable procedures:
- (1) Removing the remote control rod, operating wheel, and suction valve and replacing the valve with a spacer of equivalent size.
  - (2) Removing the remote control rod, operating wheel, remote control suction valve bonnet, valve disc, body seat ring, and guide bridges and replacing the valve bonnet with a steel cover plate of appropriate size.
  - (3) Removing the remote control rod, valve stem, and disc and installing a screwed plug or bolted gasket and washer over the stuffing box hole to create a tight valve bonnet.

---

## 5. Cargo and Vital or Critical System Piping Repairs

Repairs to cargo and vital or critical system piping systems are classified as emergency, temporary, or permanent in nature. Emergency repairs are made to permit the completion of cargo discharge. Temporary or permanent repairs must be required prior to loading of another cargo. Temporary repairs may be acceptable for isolated defects in otherwise good piping; such as a pit. Temporary repair methods include the use of substantial pipe clamps, repair sleeves, and similar devices capable of withstanding operating pressures and temperatures. Permanent repairs are made by an isolated welded doubler or renewal in kind, and are required upon the next gas-freeing or repair period, whichever is sooner. Generally, piping with a localized, isolated defect and otherwise in good condition may be repaired permanently with a doubler.

Policy continues on B1-52.

**SECTION B: DOMESTIC INSPECTION PROGRAMS****CHAPTER 1: INSPECTION OF VESSELS FOR CERTIFICATION**

**NOTE:** Piping restored to service by any of these methods should be appropriately tested upon completion of repairs.

---

**6. Fuel Piping Systems**

Fuel supply and service piping, including piping provided by engine manufacturers, should be carefully inspected. Fires have resulted from the cracking of fuel supply lines and injector couplings due to vibration. All fuel systems should be checked for proper mounting, expansion joints, filter arrangements and spray shields.

**J. ELECTRICAL INSPECTIONS**

---

**1. Introduction**

At each inspection for certification, the inspector must examine the vessel's electrical equipment and apparatus, the arrangement and materials of the installation, and the operating condition of the installation as required by the regulations. The main purpose of electrical inspections is to ensure the adequacy and reliability of shipboard electrical systems, to improve personnel safety by minimizing electrical shock hazards, and to minimize the danger of fire originating within the electrical system.

---

**2. Scope of Inspection**

The scope of the electrical inspection is detailed in 46 CFR 176.806 for small passenger vessels and in 46 CFR 110.30 for other vessels. The inspection includes the examination and testing of electric generators, motors, wiring circuits, junction boxes, fixtures, and other electric installations. No electrical repairs or alterations affecting the safety of the vessel, its equipment, and crew may be made without the knowledge and approval of the OCMI. Drawings must be approved before work is started when the repairs will involve alterations. See MSM Volume II, Material Inspection, COMDTINST M1600.7A (series), Chapter A4 for more information concerning the inspection of electrical equipment used on vessels.

---

**SECTION B: DOMESTIC INSPECTION PROGRAMS****CHAPTER 1: INSPECTION OF VESSELS FOR CERTIFICATION****3. General Applicability and References**

The standards for the inspection of electrical installations on all vessels except small passenger vessels are contained in 46 CFR Subchapter J. As indicated in 46 CFR 110.10, these regulations are supplemented by recognized specifications, standards, and codes. 46 CFR Subchapter J applies to small passenger vessels only insofar as they are made applicable by 46 CFR Part 183. Vessels contracted for prior to November 19, 1952, are not fully subject to the requirements in 46 CFR Subchapter J. The electrical installations on these older vessels may be maintained as long as their condition is satisfactory to the OCMI, unless amended regulations specifically apply to these vessels. However, major alterations or extensions to such electrical installations must be made according to the requirements of 46 CFR Subchapter J. Additional reference material can be found in the Institute of Electrical and Electronic Engineering (IEEE), American Society for Testing and Materials (ASTM), American National Standards Institute (ANSI), National Electric Code (NEC), International Electrotechnical Commission (IEC), the old 46 CFR Subchapter J (pre-June 1996 editions), NVIC 2-89 Guide for Electrical Installations on Merchant Vessels and MODUs, NVIC 9-84 Electrical Installations in Agricultural Dust Locations, and Underwriters Laboratory Inc. (UL) Publications.

**4. Initial Electrical Inspections**

- a. When carrying out tests and inspections prescribed in 46 CFR 110.30, the inspector must pay particular attention to the items detailed in the following paragraphs. These tests and inspections should be completed at the discretion of the marine inspector and/or the OCMI.
  - (1) Extreme caution must be exercised during all inspections and tests. Inspections and tests will be conducted by the shipbuilder, the owner, or the owner's representative and observed by an inspector. Test and inspection data must be recorded and obtained for checking and reference purposes.
  - (2) For more detailed plan approval information, see MSM Volume IV, Technical, COMDTINST M16000.9 (series).
- b. Electrical cable. Electrical cable must be checked during installation for size and type as shown on the approved plans. The adequacy of cable supports must also be checked.
  - (1) Cables should not be located near pipes and hot objects, and they should not have been damaged during installation by excessive pulling, sharp bends, sharp or rough edges of cable supports or bulkhead penetrations, or similar conditions.

## SECTION B: DOMESTIC INSPECTION PROGRAMS

## CHAPTER 1: INSPECTION OF VESSELS FOR CERTIFICATION

- (2) Cable penetrations required to be watertight should be checked for proper packing of terminal or stuffing tubes, including areas provided for future take-up of gland units.
  - (3) Cable penetrations through Class A and Class B bulkheads and decks should be checked for compliance with approved methods.
- c. Insulation resistance. All electric power and lighting cables, generators, and vital systems motors must be checked for proper insulation to ground and between conductors.
- (1) The insulation resistance measuring instrument (megger) used should be of the 500 volt, direct-current type, except for equipment where the normal operating voltage is less than 100 volts, in which case a direct reading ohmmeter of the appropriate voltage should be used.
  - (2) Insulation resistance varies considerably with humidity, amount of exposed copper, etc. Therefore, it is difficult to establish firm rules to guide the inspector. Generally, Figure B1-4 should be used as a guide in determining minimum acceptable values of insulation resistance. Ordinarily, on a dry day and with new, clean equipment, resistance should not be less than the values indicated in the figure. The insulation resistance in megohms must be at least equal to that determined by the formula in Figure 6-4.
- d. Group control panels. When two or more motor controllers are grouped into a central panel and supplied by a common feeder, the panel must be checked for compliance with the requirements of 46 CFR 111.70.
- (1) Each controller, its associated motor overcurrent protective device, its motor branch circuit overcurrent protective device, and disconnecting mechanism must be mounted in a common enclosure with a disconnect device that prevents the door from being opened when the circuit is energized. The enclosure must be either drip-proof or watertight, depending on its location.
  - (2) Adequate working space should also be provided. This generally should be no less than 76 cm (30 in) in front of the enclosure and in no case less than 18 inches in the rear when access to the rear may be necessary.

**SECTION B: DOMESTIC INSPECTION PROGRAMS**

**CHAPTER 1: INSPECTION OF VESSELS FOR CERTIFICATION**

**FIGURE B1-4  
INSULATION RESISTANCE**

**GENERAL INSULATION RESISTANCE FORMULA FOR VITAL MOTORS AND GENERATORS**

$$R \text{ (In Megohms)} = \frac{E}{KVA + 1,000}$$

$$100$$

Where: E = Rated line to line voltage of the machine.

KVA = Rated kilovolt amperes.

**GENERAL RESISTANCE TABLE FOR CABLE1**

<b>MINIMUM CIRCUIT</b>	<b>INSULATION RESISTANCE</b>
0 – 5 amperes, inclusive	2.0 megohms
6 – 10 amperes, inclusive	1.0 megohms
11 – 25 amperes, inclusive	400,000 ohms
26 – 50 amperes, inclusive	250,000 ohms
51 – 100 amperes, inclusive	100,000 ohms
101 – 200 amperes, inclusive	50,000 ohms
Over 200 amperes	25,000 ohms
The values for a circuit should be determined with the circuit de-energized, with all switches or circuit breakers connected in the circuit closed, and with all panelboards, controllers, fuses, and fuseholders in place.	

- e. Generators. Generators must be checked for general condition (both electrical and mechanical), voltage regulation, parallel operation, operation of safety devices such as reverse-current or reverse-power trips, overcurrent trips, overspeed trips, low-oil pressure trips, and similar devices (see 46 CFR 111.12).
- f. Rotating electric machinery. Rotating electric machinery must be checked to ensure that rotating and uninsulated electric parts are adequately shielded from accidental contact by personnel. Nameplate data must be examined for correct ratings for the particular application (see 46 CFR 111.01 and 111.25).

## SECTION B: DOMESTIC INSPECTION PROGRAMS

## CHAPTER 1: INSPECTION OF VESSELS FOR CERTIFICATION

- g. Switchboards. Switchboards must be checked for nonconducting handrails, guardrails, working spaces, insulating floor coverings, drip covers, and shields.
- (1) Switchboard enclosures must be checked for proper construction in accordance with 46 CFR 111.30.
  - (2) Switchboard mounted apparatus must be checked for identifying nameplates.
  - (3) Circuit nameplates must be compared with the rating or setting of the overcurrent devices and with approved plans.
  - (4) The accessibility of items requiring maintenance or adjustment must be checked.
  - (5) Meters must be checked for proper operation.
  - (6) The operation of automatic switchgear and interlocks must be observed (see 46 CFR 111.30).
- h. Panelboards. The rating or setting of the overcurrent devices must be compared with the values given on the circuit directory and the approved plans. The accuracy of the directory description of loads served by each circuit must also be checked (see 46 CFR 111.40).
- i. Motor starters. Motor starters must be checked to ensure proper starting under service conditions with properly rated motor overload protective devices.
- (1) Enclosures must be checked to ensure that they are drip-proof or watertight and that required door positioners are installed on doors with a height of more than 45 inches or a width greater than 24 inches.
  - (2) A fixed heat-resistant wiring diagram for each motor starter must be on the inside of its enclosure door.
  - (3) Each motor starter not disconnected from all sources of potential when the disconnect switch is opened, due to electrically interlocked circuits that are necessary for proper operation of the apparatus or for other valid reasons, must have a warning sign directing attention to these conditions (see 46 CFR 111.70).



## SECTION B: DOMESTIC INSPECTION PROGRAMS

**CHAPTER 1: INSPECTION OF VESSELS FOR CERTIFICATION**

- j. Disconnect switches. The presence and location of disconnect switches required for motor starters, fuses, etc., must be checked. When a switch or circuit breaker is intended to serve as a motor and controller disconnect switch, the inspector must ensure that the applicable requirements have been met (see 46 CFR 111.55 and 111.70 and National Electrical Code Article 430, Part H).
- k. Accessibility. The inspector must observe the accessibility of electrical apparatus for inspection and maintenance.
  - (1) The inspector must also note the accessibility of junction boxes and similar apparatus in way of paneling.
  - (2) The inspector must check hinged doors of motor starters and similar apparatus for interference with adjacent structural parts or apparatus.
- l. General alarm systems. The inspector must check the general alarm system with a sound level meter and measure the sound level of the bells in each stateroom with the doors closed. Where the background noise level is questionable, the sound level should be measured while the vessel is underway (see 46 CFR 113.25-9).
- m. Electric installations in hazardous locations. During the initial inspection for certification, the inspector must check the emergency loudspeaker system with a sound level meter at each lifeboat handling station, each lifeboat embarkation station, each passenger assembly station, and throughout the crew's quarters. Where the background noise level is questionable, the sound level should be measured while the vessel is underway or the required sound levels.
- n. Emergency loudspeaker systems. The inspector must check electric equipment and wiring in hazardous locations for compliance with 46 CFR 111.105.
  - (1) Intrinsically safe systems must be checked to ensure that they are installed in accordance with the plans and instructions required by 46 CFR 111.105-11.
  - (2) Equipment required to be explosion-proof or intrinsically safe must also be checked for proper Underwriters Laboratories, Inc. (UL), Factory Mutual Research Corporation (FM), Canadian Standards Association (CSA), or MET Electrical Testing Company (MET) labels.
- o. Steering gear circuits. Steering gear circuits must be separated. Steering gear motor controllers must be located in the steering gear room.
- p. Emergency firepump circuits. Circuits for emergency firepumps must not pass through the engine room or boiler room.

## SECTION B: DOMESTIC INSPECTION PROGRAMS

## CHAPTER 1: INSPECTION OF VESSELS FOR CERTIFICATION

- q. Low voltage release tests. The inspector must determine that motor controllers have low voltage release and that motor controllers prohibited from having low voltage release have low voltage protection.
- (1) All motors should be run simultaneously and all generators then tripped off the line. One generator should be placed back on the line; it should not trip because of the oncoming load.
  - (2) Motor controllers requiring low voltage release should re-start their motors automatically; those prohibited from having low voltage release should not re-start their motors automatically. If the motor load exceeds the total ship's service generating capacity, this test should be conducted with all motors that have low voltage release and sufficient motors with low voltage protection, adding up to the total generating capacity running.
  - (3) A second test must then be conducted with the remaining motors; none of the motors in this second test should start automatically.

---

## 5. Equipment

- a. Miscellaneous electrical. The Coast Guard no longer grants type approvals for miscellaneous electrical equipment. Electrical equipment can be divided into the following categories, although some equipment approvals may require a combination of categories:
- (1) Required to be approved. Equipment that is required to be approved is listed in 46 CFR Subchapter Q and will have an approval number assigned.
  - (2) Required to meet various standards. Equipment that is required to meet various standards is discussed in 46 CFR Subchapter J. It is important to note that the requirement is to meet the standard, not to be listed by a listing service. The burden of proof that the standard is met rests with the manufacturer.
  - (3) Having specific requirements in 46 CFR Subchapter J. The index following Subchapter J may be used to identify if certain equipment must satisfy additional 46 CFR requirements.
  - (4) Required to be explosion-proof or intrinsically safe. Equipment required to be explosion-proof or intrinsically safe must be listed by UL, FM, MET, or CSA.
- b. Use of miniature thermal overcurrent circuit breakers on small passenger vessels. In 1997, Commandant (G-MSE-3) concurred based on supporting

## SECTION B: DOMESTIC INSPECTION PROGRAMS

## CHAPTER 1: INSPECTION OF VESSELS FOR CERTIFICATION

documentation from MSO New Orleans that the “new” standard noted in the CFR is excessive,

and the use of miniature thermal overcurrent circuit breakers on small passenger vessels is acceptable for low voltage DC circuits less than 50 Volts, provided:

- (1) Circuit breakers may meet UL 489, or
- (2) Circuit breakers may meet UL 1077, Supplementary Protectors for use in electrical equipment, if:
  - i. an NRTL has verified that they meet UL 1077;
  - ii. they are installed in a panelboard; and
  - iii. there is at least one UL-listed fuse or UL 489 certified breaker protecting the main feeder to the panelboard to provide primary branch circuit protection.

**CHAPTER 1: INSPECTION OF VESSELS FOR CERTIFICATION**

Policy continues on B1-59.

---

## SECTION B: DOMESTIC INSPECTION PROGRAMS

## CHAPTER 1: INSPECTION OF VESSELS FOR CERTIFICATION

**6. Subsequent Electrical Inspections**

- a. In subsequent tests and inspections, inspectors must pay particular attention to the items listed in this section of the manual. The inspector must determine mechanical and electrical conditions, performance, safety of personnel against shock hazards, and safety of the vessel from fire hazards.
- b. New and modified circuits. The inspector must give special attention to circuits and equipment added or modified since the last inspection to determine that they comply with the regulations.
- c. Navigation lights. The inspector must examine navigation lights for corrosion of materials and for satisfactory condition of portable cable and receptacles. Navigation light panels must be tested for satisfactory operation and proper functioning of alarms.
- d. Lifeboat winch electrical equipment. All enclosures for electrical lifeboat winch control equipment, such as limit switches, master switches, and emergency disconnect switches, must be opened and examined for evidence of water or corrosion.
  - (1) In particular, the inspector must pay attention to the proper functioning of limit switches and emergency disconnect switches in the control circuits of lifeboat winches. Casualty investigations have indicated the need to specifically examine the clutch interlock switches on dual winches, such as those on Victory-type cargo ships.
  - (2) It is essential that satisfactory limit switches and emergency disconnect switches be used with gravity davits and power-operated winches. Therefore, a test operation of the lifeboat winch controls, including limit switches, emergency disconnects, and clutch interlocks where employed, must be conducted at each annual inspection.
- e. Watertight doors. The inspector must thoroughly check the watertight door systems to verify that they are in satisfactory operating condition.
  - (1) The enclosures for all local control door switches and controllers should be examined for evidence of water or corrosion. It has been found that seawater entering the local control switch located at the watertight door may cause faulty operation of electrically operated watertight doors. If seawater has entered the switch enclosure, it may short circuit the motor starter and motor so that the door opens even with the wheelhouse control indicating the closed position.

**SECTION B: DOMESTIC INSPECTION PROGRAMS****CHAPTER 1: INSPECTION OF VESSELS FOR CERTIFICATION**

- (2) To the extent practical, the inspector must also be satisfied that the ship's personnel are familiar with the watertight door system, location of disconnect switches, etc.
- f. Electrical cables. The inspector must determine condition of cables by insulation resistance readings and by visual observations. Deterioration of the armor of a cable that is otherwise in good condition is not considered sufficient cause for requiring replacement.
- g. Ground detection systems. Ground detection systems should function properly. Where lamps are used, they should be of the proper wattage with the connections between the lamps grounded. Ground faults must be cleared.
- h. Temporary wiring and installations. Long extension cords, jury-rigs, or temporary modifications are not satisfactory installations.
- i. Portable electric equipment. New and replacement items must meet the Coast Guard requirements. Existing equipment must be serviceable and free from potential shock or fire hazards.
- (1) Metal bodies of these items must be grounded through grounding leads in the portable cord. To be effective, the grounding conductor on a tool or light must be connected to a grounding terminal. This conductor must be electrically continuous (the wire should not be broken anywhere along its length); this can be checked with an ohmmeter or megger.
- (2) For portable devices made entirely of nonconducting material, or so constructed that dead metal parts will not become energized under any condition (double insulated construction), the grounding conductor in the portable cord and the grounding pole of the attachment plug need not be furnished. No splices or patching should be permitted in portable leads smaller than No. 12 American Wire Gauge (AWG). Splices must be in accordance with 46 CFR 111.60-19.
- (3) Careful checks must be made of the condition of the cord where it enters the light or tool. This is a location of severe stress and bending fatigue, especially on items such as portable cargo lights. Cracking, brittleness, and heat discoloration of the cord at this point are sufficient reasons for rejection. If the device is to be rewired, only cords indicated in 46 CFR 111.60-13 for hard or extra-hard service should be used.

## SECTION B: DOMESTIC INSPECTION PROGRAMS

## CHAPTER 1: INSPECTION OF VESSELS FOR CERTIFICATION

- (4) Lighting fixtures should be examined to see that the interior insulation is satisfactory, particularly the lamp holder. Cracked porcelain or plastic lamp holders should be replaced. Devices in which the exterior case is cracked or damaged should be replaced or repaired.
- j. Fire and smoke detection systems. Fire and smoke detection systems must be checked regularly, and faulty detectors must be recalibrated or replaced. Refer to 161.002-1(b) for applicable standards of design, construction, testing, marking and installation.
- (1) Thermal detectors. Thermal detectors may be tested by replacing the guard and globe with a sheet metal shield and using a portable light as the heat source; this will not cause damage to the adjacent paintwork. The activation temperature range should be as specified in 46 CFR 161.002-11.
- (2) Photoelectric and ionization smoke detectors. Photoelectric and ionization smoke detectors may be tested by holding pink sticks or other smoke source near the detector.
- (3) Infrared detectors. Infrared detectors may be tested with a candle or other flame source. Infrared detectors often have a response delay.
- k. Vital machinery. Motors, motor starters, and control switches used with machinery vital to the safety or propulsion of the vessel must be visually examined for condition and suitable nameplate ratings. When there is evidence of deterioration, they must be opened for closer inspection.
- l. Electrical cooking equipment. Electrical cooking equipment must be maintained in good condition. There should be no evidence of grease or dirt buildup or deterioration of the equipment.

---

**K. LEAKAGE ONTO PROPULSION CONTROL CIRCUITS, SWITCHBOARDS, ETC.**

The 1974 casualty to the tank vessel TRANSHURON was caused by water spraying onto the main propulsion control area from a failed cooling water gauge nipple for the vessel's air conditioning system. In another similar casualty, water leaked onto a vessel's main switchboard from an exterior electrical junction box that had filled with water. The conduit and wire provided the path to the switchboard. These casualties demonstrate that shielding or other measures must be used to guard against accidental discharge of water onto electrical propulsion installations. All water lines must be located clear of control circuits, electrical equipment, and areas of high voltage whenever possible. Cables to switchboards, controllers, etc., should be connected so as to prevent water from entering connectors, through use of drip loops, joining cables to the bottom side of the installation, or similar methods.

---

## SECTION B: DOMESTIC INSPECTION PROGRAMS

## CHAPTER 1: INSPECTION OF VESSELS FOR CERTIFICATION

**L. EMERGENCY LIGHTING AND POWER SYSTEMS****1. Introduction**

Casualty reports indicate that, in some instances, emergency diesel generators and associated equipment are not maintained in a satisfactory state of readiness for emergency use.

46 CFR 35.10-15, 78.17-45, and 97.15-30 require vessel personnel to periodically test installed emergency lighting and power systems and record the results in official logbooks. The regulations for tank vessels, passenger vessels, cargo and miscellaneous vessels, and the electrical engineering requirements require testing of emergency lighting and power installations to occur in the presence of an inspector.

Testing of a properly functioning emergency plant can be accomplished quickly, with little or no interruption of normal service. 46 CFR Table 112.05-5(a) notes which vessels required are to have an emergency source of power that meets the requirements of 46 CFR 112. Also, see NVIC 2-89 Electrical Installations on Merchant Vessels and MODUs.

**2. Testing**

At each inspection, and whenever emergency drills are conducted, light and power emergency systems must be tested as follows:

- a. Automatic starting and connecting power systems. Automatic starting and connecting power systems should be tested by using the test switch. When the switch is put in the test position, the following should occur in less than 45 seconds:
  - (1) The Bus-tie breaker should open.
  - (2) The power source should automatically start (if the power source is a battery, this step will be skipped).
  - (3) The required loads should be transferred to the emergency power source when the voltage reaches 85-95 percent of final value, i.e., the generator circuit breaker closes. This will happen immediately for a battery source. Upon completion of the test, loads should be transferred back to the normal source and the emergency system set up for automatic operation.
- b. Manual transfer system. For a manual transfer system, test as indicated above, except that step 2 will occur as the result of a manual action. All other functions remain automatic.



**SECTION B: DOMESTIC INSPECTION PROGRAMS****CHAPTER 1: INSPECTION OF VESSELS FOR CERTIFICATION**

- c. Alarm relay circuits. When conducting operational tests of the emergency diesel generator for initial certification or after modifications have been made, inspectors should have the shipboard personnel conducting the test temporarily disconnect any remote alarm relay circuits. When this is done, the emergency diesel generator should continue to function. If the generator fails to operate with the remote alarm relay circuits disconnected, the inspector should issue a requirement to modify the installation to allow operation of the emergency diesel generator with these circuits disabled. At the conclusion of this test, the inspector should ensure that remote alarm circuits are properly reconnected.
- d. Alternatives. Some passenger vessels contracted for prior to 19 November 1952 may not be arranged for testing as outlined above. Tests of such vessels should be performed in a manner compatible with their arrangements.
- (1) Many older vessels have an inport or standby generator (and no emergency plant, as such). These are usually arranged to feed directly to the main switchboard, and cannot be tested in the manner outlined above.
  - (2) The testing of such standby units must be prescribed by the OCMI.

---

**M. INSPECTION OF RADIO EQUIPMENT**

---

**1. General Practices**

- a. Cooperation with the FCC. When the OCMI is notified by representatives of the Federal Communications Commission (FCC) that a vessel's radio installation contains technical deficiencies, the Safety Radiotelephony or Radiotelegraphy Certificate should be withheld until the deficiencies are corrected and the OCMI receives formal notice to that effect from the FCC.
- b. Interagency resolution of deficiencies. In cases where technical deficiencies exist in a vessel's radio installation on a vessel already in possession of a Safety Certificate, the OCMI must withdraw the certificate upon the FCC's request.
- (1) Inspectors should consult with local FCC representatives before taking action in such circumstances, and must cooperate fully with FCC inspectors to carry out the intent of these instructions.
  - (2) The COI should not be withheld or withdrawn for technical deficiencies in radio installations.

**SECTION B: DOMESTIC INSPECTION PROGRAMS****CHAPTER 1: INSPECTION OF VESSELS FOR CERTIFICATION**

- c. The inspector should remember that the technical adequacy of the radio installation, the suitability of electrical wiring to interconnect components of the radio, and the proper maintenance and efficient operation of the equipment are determined solely by FCC inspectors.
- (1) The suitability of power leads from the main power supply to the main installation in the radio room is solely the responsibility of the Coast Guard. All electrical wiring in the radio room not connected with the radio installation itself is under the sole jurisdiction of the Coast Guard.
- (2) The amount of power and character of the supply, however, must be determined by the FCC to operate the radio installation and its auxiliary equipment properly and efficiently. The FCC will notify the OCMI of any observed inadequacies in the power supply; the OCMI must ensure that such deficiencies are corrected.
- d. See MSM Volume II, Material Inspection, M16000.7 (series), Chapter E2 regarding Safety Radiotelegraphy and Safety Radiotelephony Certificates, and MSM Volume II, Material Inspection, COMSTINST M16000.7 (series), Chapter C2 regarding portable lifeboat radio equipment.
- e. See Table 47 CFR Part 80, for general information and citations regarding FCC regulations.

---

**2. Emergency Radio Gear**

The installation of all ship's radio equipment must be approved by the Coast Guard. The inspector must be satisfied that the main and emergency radio installations are located in the superstructure of the ship, as high as is practical above the highest marked load line. The emergency installation must be provided with a source of power independent of the propulsion and main electrical systems; it must be capable of being energized rapidly and operating continuously for at least 6 hours.

**NOTE:** Use of the emergency radio power for other than radio equipment and emergency lights in the radio room is prohibited.

---

**N. HAZARDS AND UNSAFE PRACTICES**

---

**1. Introduction**

The following guidance is intended to promote the detection, reporting, and correction of those practices and situations that tend to cause injury or death to personnel and damage to the vessel or its cargo. Safety considerations based on good marine practice are directly

**SECTION B: DOMESTIC INSPECTION PROGRAMS****CHAPTER 1: INSPECTION OF VESSELS FOR CERTIFICATION**

related to the equipment and construction to which attention is directed by the regulations, and for which separate reports are required. Obviously, a vessel with defective cargo gear, dangerous gangways or access ladders, unguarded openings in the holds, poorly lighted working spaces, or similar hazards should not be determined to be suitable for service. Traditionally, it is the duty of the vessel's officers to see that dangerous conditions are corrected immediately. Aspects of good marine practice may not always be spelled out in statutes or regulations; doing so is sometimes impractical. Practices of good seamanship and good shipkeeping will vary according to the size, design, and operating conditions of a particular vessel. However, it is of paramount importance that general safety considerations are kept in mind aboard vessels at all times. When hazardous conditions are noticed, immediate steps must be taken to keep working conditions as safe as reasonably possible.

---

**2. Statutory Requirements**

Congressional statutes regarding safety of life and property on board vessels apply at all times when a vessel is in service, whether alongside the dock, anchored, or underway. The statutes in 46 U.S.C. Chapter 33 authorize the Coast Guard to inspect ships periodically for safety purposes.

---

**3. Responsibility of the Crew**

The master and other ship's officers are responsible for maintaining safe working conditions. They are also responsible for supervising or establishing proper supervision of all employees aboard a vessel. A competent ship's officer must supervise all hazardous work. Any ship's officer who is inattentive to duty or negligent in permitting unsafe conditions or practices should be admonished. If the situation is sufficiently severe, the failure should be charged against that officer's license. The primary objectives are to improve safety and to indoctrinate ship's officers in their responsibilities. However, all persons employed aboard have a mutual responsibility to carry out established procedures for the safety of themselves and their fellow mariners.

---

**SECTION B: DOMESTIC INSPECTION PROGRAMS****CHAPTER 1: INSPECTION OF VESSELS FOR CERTIFICATION****4. Responsibility of the Coast Guard**

A marine inspector or other Coast Guard boarding officer should be alert to unsafe practices and hazardous situations when aboard an inspected or uninspected vessel for any purpose. The inspector must take proper and immediate action to have unsafe practices stopped and hazardous situations remedied. Such action will, of course, vary according to the situation. In many cases, calling the attention of the ship's officers or master to the situation will be sufficient. In certain instances, it may be necessary to issue a Vessel/Facility Inspection Requirements, Form CG-835 to cover a deficiency. Serious cases, or those in which there is disagreement over the proper course of action, should be brought to the attention of the OCMI immediately. Revocation of the vessel's COI, action against an officer's license, or submittal of a Report of Violation should be undertaken when necessary. To ensure the greatest possible degree of safety on vessels operating in their jurisdiction, an OCMI must give personal attention to reported instances of unsafe practices and hazardous situations on vessels in their zone.

**5. Remedies for Hazardous Situations**

- a. General practices. All exposed dangerous areas and installations must be properly protected with covers, guards, or rails.
  - (1) Regulations also specify the height and number of courses of rails on passenger and crew decks.
  - (2) There should be two avenues of escape from every area within a vessel where passengers or crew may be quartered, or where anyone may normally be employed (see 46 CFR 32.02-1, 72.10-5, 92.10-5, and 190.10-5). While it is not always possible to provide such exits from cargo holds, the means of escape provided from these should be adequate and easily accessible.
- b. Refrigerants. All refrigerants must be recognized as potentially dangerous substances and treated accordingly.
  - (1) The dangers involved in the use and transportation of dry ice and carbon dioxide as refrigerants are often overlooked. The dangers of dry ice were published, but only after a series of deaths of stevedores and crewmembers related to circumstances where dry ice was used as a refrigerant.
  - (2) Container cargo may be refrigerated by introduction of liquid nitrogen into the container, where it evaporates and thus chills the contents. Unless sufficient time elapses for complete evaporation before the container is loaded aboard ship, there is a risk of spillage of the liquid nitrogen. Since the temperature of liquid nitrogen (-320°F) cannot be withstood by ordinary ship steel, spillage can result in

## SECTION B: DOMESTIC INSPECTION PROGRAMS

## CHAPTER 1: INSPECTION OF VESSELS FOR CERTIFICATION

fractures. Carbon dioxide and nitrogen can be asphyxiating when concentrated in tanks or holds.

- c. Boiler torch pots. Pots should be secured in a vertical position, not at an angle. Low flash point liquids should never be used in torch pots, and fireroom personnel should be instructed in the dangers of any highly combustible liquid having a flash point lower than that of commercial kerosene, which is used for moistening the torch.
- d. Gratings. Some machinery spaces lack gratings over the top of the main condensers to provide safe platforms for oiling the intermediate pressure links, adjusting the cutoffs, and accessing the indicator cocks. A grating with handrails over the main condenser is required to ensure the safety of engineroom personnel during the performance of their duties; its requirement comes within the intent of 46 CFR 32.01-15 and 58.01-20. (For more information, see MSM Volume II, Material Inspection, COMDTINST M16000.7 (series), Chapter A5.)
- e. Fuel oil in bilges. At annual inspections, the inspector must examine the bilges and tank tops beneath the boilers and in any compartment in which oil burning equipment or fuel tanks are installed, to ensure that there are no accumulations of fuel oil that constitute a fire hazard.
- f. Sparks and stack fires. Sparks or stack fires can result from the heating of soot and carbon deposits in preheaters, economizers and uptakes in boilers, and in exhaust manifolds and mufflers in diesels.
  - (1) A stack fire is particularly hazardous because it can develop undetected and then materialize many hours after the machinery plant is secured, when fresh air reaches the hot carbon deposits. Some vessels have had stack fires long after the crew has departed at a shipyard or layup pier.
  - (2) As a precaution against stack fires or sparking, it is necessary to keep all uptakes and mufflers clean. This is best accomplished by efficient combustion and plant operation and attention to periodic maintenance and cleaning. Inspectors require the opening of adequate access plates to inspect thoroughly those areas where carbon may accumulate.

---

## 6. Preventing Boiler Gas Explosions (Flarebacks)

Flareback in the furnace of a watertube boiler may be caused by the ignition of gases accumulating from vaporized oil that entered the furnace improperly, or ignition of vapors that have not been purged from the furnace before the lighting off.

**SECTION B: DOMESTIC INSPECTION PROGRAMS****CHAPTER 1: INSPECTION OF VESSELS FOR CERTIFICATION**

The following procedures must be brought to the attention of all engineering personnel, to reduce the hazards of flarebacks:

- a. Before attempting to light off the first or additional burners, ensure that properly heated oil is available at the burner to be lighted. The recirculation line is provided for this purpose.
- b. Before installing an atomizer, ensure that it is fitted with a sprayer plate, and that the burner tip is tightly made up.
- c. Before lighting the first burner or lighting off a burner again after all have been extinguished, the forced draft fan should be run long enough, with double front damper and burner registers wide open, to ensure that the furnace is properly purged.
- d. When lighting off the first burner, always use a torch. Never attempt to light a burner from hot furnace brickwork.
- e. With the torch lit and in proper position, the last valve in the branch connection leading from the fuel oil header supply line to the burner should be slightly opened. As soon as ignition occurs, this valve should be fully opened. If ignition does not immediately occur, the burner valve should be closed and the furnace thoroughly purged. This entire operation should be repeated until ignition occurs.
- f. While a burner or burners are in service, the register door(s) should be wide open, and the oil temperature and pressure should be closely monitored. Cold oil or low oil pressure may cause the fires to die out; water in the oil may do the same. Should all burners be extinguished, the valves in the individual branch connections to the burners should be closed, the forced draft fan should be kept on, the double front damper and all burner register doors should be opened wide, and the furnace should be thoroughly purged before another attempt is made to light the burner.

---

**7. Lighter-Aboard-Ship (LASH) Vessel Lighter Cranes**

- a. The extension of lighter guides aboard Lighter-Aboard Ship (LASH) barge-handling cranes may create significant personnel safety hazards. In separate incidents, despite various safety precautions, two mariners and three longshoremen were killed while lighters were being discharged. These people were caught by the hydraulically extended lighter guides of the LASH cranes and crushed against the barges.
  - (1) Operators of LASH vessels must take corrective action in accordance with 46 CFR 92.25-15.
  - (2) No specific method of personnel protection is required. However, such action must provide a degree of safety equivalent to that afforded by—

**SECTION B: DOMESTIC INSPECTION PROGRAMS****CHAPTER 1: INSPECTION OF VESSELS FOR CERTIFICATION**

- (a) A mechanism to provide a delay of at least 3 seconds' duration, from actuation of the lighter guide extension controller and initial movement of the guide arms; and
  - (b) A distinctive, continuously sounding alarm, to begin sounding at the delay period before guide extension. An alarm speaker must be located on each crane leg, in immediate proximity to the point(s) of danger.
- b. The lighter crane on every LASH vessel must be examined at each inspection and reinspection for certification to ensure that the hazards described above have been corrected through the installation of guards, rails, and warning devices. Plans and specifications for such installations must be reviewed by the cognizant OCMI.

---

**8. Explosions in Diesel-Fired Boilers**

A number of explosions have occurred in auxiliary boilers that burn diesel oil. Many of these explosions have occurred on dual-fuel fired boilers upon switch over from diesel to heavy oil. These vessels had common fuel piping and heater systems. When the heavy oil and heater were switched in, a slug of diesel was also heated, which altered the fuel-air mixture. Common fuel piping is prohibited because of fuel and burner nozzle tip contamination problems. An explosion can occur when the fuel-air mixture in the furnace is not properly controlled. Even very small accumulations of fuel oil in the boiler can produce explosive mixtures. Automatic control systems for diesel oil should therefore be very reliable and properly designed, operated, and maintained. At each inspection of a vessel equipped with diesel-fired boilers, the inspector must ensure that the following procedures are followed:

- a. Fuel oil shutoff valves are inspected or tested to ensure that there is no leakage.
- b. Controls to shut down the boiler due to flame failure are tested to ensure safe boiler operation.
- c. To prevent a vapor buildup from residual fuel in the furnace, no time should elapse between a furnace purge and a light off or ignition trial.
- d. Dual fueled boilers that heat a heavier oil should be examined to ensure that the piping of the lighter oil does not go through the heater.

---

**9. Galley and Laundry Room Exhaust Ducts**

**SECTION B: DOMESTIC INSPECTION PROGRAMS****CHAPTER 1: INSPECTION OF VESSELS FOR CERTIFICATION**

A number of shipboard fires have originated in the exhaust ducts of galley ranges, fryers, and laundry room ventilation systems. These fires have resulted in serious damage, injury, and loss of life aboard the vessels involved. Unmaintained exhaust duct work will become saturated with cooking grease and pose a fire hazard.

Such areas have sometimes been overlooked during vessel inspections. The following procedures must be followed during biennial and mid-period inspections of U.S. vessels and during SOLAS verification examinations of foreign vessels:

- a. On all vessels--
    - (1) Remove the inspection plate from the galley exhaust duct;
    - (2) Disconnect the fusible link, if installed, and test the operation of the fire damper;
    - (3) Remove sufficient inspection plates to ensure that the duct work is clean and free of grease. Pay particular attention to long, horizontal duct runs;
    - (4) Examine all hood screens for cleanliness;
    - (5) If an extinguishing system is installed, ensure that it is in proper working condition; and
    - (6) Examine laundry room vents, ask if the company has a cleaning and maintenance program (check records – part of ISM/SMS responsibility).
  - b. On passenger vessels only, the inspector must also--
    - (1) Remove sufficient overhead panels to ensure that the galley exhaust duct is suitably insulated, in accordance with SOLAS standards and applicable U.S. regulations. Unless changes are made to the duct work, this part of the examination need be made only once; and
    - (2) Check all main and zone control valves of the sprinkler system to ensure that they are in the full open position.
-



## SECTION B: DOMESTIC INSPECTION PROGRAMS

## CHAPTER 1: INSPECTION OF VESSELS FOR CERTIFICATION

**10. Noise Factors in the Marine Environment**

- a. Personnel on virtually any type of vessel or unit may be exposed to damaging noise.
  - (1) Noise-induced hearing loss is a slow, progressive disorder that often goes unrecognized until it has become a pronounced handicap, generally in later years.
  - (2) Related problems, such as tinnitus (ringing in the ears) can be even worse. Excessive noise poses a potential threat to vessel safety by interfering with shipboard communications and the drowning out of signals and alarms.
- b. Initial Coast Guard actions. Previously, the Coast Guard dealt with maritime noise problems generally through existing regulations on a case-by-case basis. For example, 46 CFR 72.20-5 and 92.20-5 require accommodations aboard vessels to be insulated from undue noise. Similarly, 46 CFR 32.40-15 requires tankships and manned tank barges to have crew's quarters suitable for the accommodation and protection of the crew.
- c. Establishment of standards. In November 1981, the International Maritime Organization (IMO) published a Code on Noise Levels On Board Ships, Resolution A.468(XII). The Code applies to all vessels over 1,600 GT built after publication of the Code.
  - (1) In June 1982, the Coast Guard published NVIC 12-82, Recommendations on Control of Excessive Noise. This NVIC was developed in light of the IMO Code and is considered satisfactory implementation of the Code's standards. Therefore, vessels and units meeting the NVIC's standards are considered to meet those of the IMO Code as well.
  - (2) NVIC 12-82 deals with the entire spectrum of maritime noise and recommends a broad-based program of noise control and hearing conservation. Its two major recommendations are a 24-hour noise exposure limit of 82 dB(A) for all personnel and periodic audiometric examination of all personnel exposed to noise levels above a certain low exposure level of 77 dB(A). The only limits on noise levels (as opposed to exposure levels) apply to berthing spaces, and messing spaces on vessels over 1600 GT. These limits are 75 dB(A) for existing vessels and units, and 70 dB(A) on vessels and units constructed after December 31, 1985.

## SECTION B: DOMESTIC INSPECTION PROGRAMS

## CHAPTER 1: INSPECTION OF VESSELS FOR CERTIFICATION

- d. Inspection procedures. NVIC 12-82 is based on the expectation that the maritime industry will voluntarily implement and maintain an effective noise control program without direct Coast Guard involvement. This policy was developed with the assistance of industry and the Commandant anticipates its wide implementation.
- (1) The role of inspection personnel is primarily to promote NVIC 12-82 and to note its effects. Therefore, there should be minimal Coast Guard enforcement concerning noise control. Inspectors should be alert to excessive noise levels during inspections, and require noise measurements to be taken to quantify levels of exposure.
  - (2) If excessive noise levels are verified, inspectors should require correction of deteriorated systems that permit production of unwarranted noise or the unnecessary transmission of noise to adjacent spaces.
  - (3) Inspectors should also examine the condition of hearing protection devices and the posting of warning signs, and verify that the vessel or unit's hearing conservation program is being followed.

**NOTE:** Complaints alleging that crewmembers have suffered hearing loss from long-term exposure to excessive noise must not be considered as reportable marine casualties involving personal injury.

- e. Handling complaints. If a crewmember files a written complaint requesting the elimination of a specific noise hazard, the situation should be evaluated and all discrepancies corrected.
- (1) The vessel owner is responsible for taking these measures, upon the request of the OCMI. Only when the OCMI has reason to question the owner's evaluations should inspection personnel become involved in noise measurement.
  - (2) Criteria for determining whether noise levels or exposure periods are excessive should normally be those stated in NVIC 12-82, namely, the noise limits for berthing and messing spaces and the 24-hour noise exposure limit. If there is objection to the application of these criteria, the owner may suggest another recognized standard that meets or exceeds the standards of NVIC 12-82. Noise control is a complex science, requiring professional expertise to evaluate problems and develop effective remedies.

**SECTION B: DOMESTIC INSPECTION PROGRAMS****CHAPTER 1: INSPECTION OF VESSELS FOR CERTIFICATION**

- f. Program review. NVIC 12-82 was issued to promote an industry standard, and to provide a methodology to evaluate noise in the marine environment. Over the next several years, the effectiveness and content of this policy will be reviewed. Effective program review can be obtained only through feedback from field units relating noteworthy experiences and observations of noise conditions and actions. Such reports and questions concerning NVIC 12-82 should be directed to Commandant (CG-CVC).

---

**O. INSPECTION OF PRESSURE VESSELS (P/Vs)**

---

**1. Test and Examination Intervals**

Periodic inspections of unfired pressure vessels (P/Vs) are required by 46 CFR 61.10. These regulations require P/V testing and examination to be conducted twice in 5 years. The testing and examination interval for bulk storage tanks containing refrigerated, liquefied CO<sub>2</sub> gas for use on board vessels as a firefighting agent should not extend beyond 10 years (120 months) from the last such test/exam. The aforesaid authorization must be exercised primarily to permit the test and examination interval to coincide with the vessel's drydocking or similar out of service availability period.

---

**2. Purpose**

Periodic examinations of P/Vs are intended to assess a P/V's condition to determine that the vessel is satisfactory to continue in service at the pressure and environment of the system for which it is being used.

---

**3. Factors Affecting P/Vs in Service**

- a. Internal. P/Vs are subject to different factors that can affect their physical conditions. Water vapor, other gases, and particulate matter can cause corrosion in P/Vs. Interior coatings can affect the thoroughness of an internal examination if they mask the condition of the covered surface. Conversely, they can give an indication of trouble if deterioration of the metal results in a change to the appearance of the coating.

**SECTION B: DOMESTIC INSPECTION PROGRAMS****CHAPTER 1: INSPECTION OF VESSELS FOR CERTIFICATION**

- b. External. Depending on where and how the P/V is mounted, cyclic loading can be transmitted to the P/V through its saddles/support framework if the foundation is subject to movement. Vibration loads are commonly transmitted to a P/V through attached piping and rotating machinery. The motion of other machinery located in adjacent areas can transmit loads through the deck and bulkheads to a P/V. Mechanical damage can occur if heavy objects contact the P/V or any of its attached piping.

---

**4. Inspection Descriptions**

- a. Visual examinations. Accessibility to the internal surfaces is the primary consideration when conducting visual examinations. Each P/V in a system regulated under 46 CFR 58.60 that is fitted with a manhole or other inspection opening so it can be satisfactorily examined internally must be opened twice within any 5-year period, with no more than 3 years elapsing between examinations. The same applies to P/Vs stamped with the Coast Guard symbol. Each P/V must be thoroughly examined internally and externally.
- (1) No P/V need be hydrostatically tested except when a defect is found that the marine inspector believes may affect the safety of the P/V.
  - (2) If a hydrostatic test is warranted, the P/V must be tested at a pressure of 1 ½ times the maximum allowable working pressure.
  - (3) Section VIII, Part UG-46 of the ASME Code has standards for openings in P/Vs. An elliptical manhole must not be less than 11" X 15" or 10" X 16"; a round manhole must not be less than 15" in diameter. Smaller openings may be acceptable if the inspector can satisfactorily examine the internal surfaces.
  - (4) The presence of a backing strip eliminates the possibility of a visual examination of the weld and may contribute to internal corrosion as a moisture trap. The presence of a backing strip does not, however, prevent the acceptance of an otherwise satisfactory visual examination. The inspector should consider other factors, such as the P/V's service, condition, other signs of internal corrosion, age, and date of last hydrostatic test, when determining whether additional testing is warranted.
- b. What to look for. All internal surfaces should be carefully examined for evidence of fractures or indications of deterioration.
- (1) The inspector should pay special attention to the heat affected zone adjacent to all welds. All welded joints, as well as all nozzle connections and similar openings,

**SECTION B: DOMESTIC INSPECTION PROGRAMS****CHAPTER 1: INSPECTION OF VESSELS FOR CERTIFICATION**

should be thoroughly examined. Problem areas of the internal surfaces include low spots where water and grit accumulate, areas adjacent to openings (particularly the drain), welds, and their heat affected zones.

- (2) Problem areas associated with the external surfaces include welded attachments, such as support webs, and areas around openings, particularly if the P/V is insulated. The external appearance of insulating materials should not be accepted as indicative of the condition of the welds or the shell and head material. If the insulation materials separate from the P/V, condensate can be trapped beneath the insulation and cause metal deterioration. The insulation should be carefully examined visually and any suspect areas should be sounded to determine the extent of separation from the P/V. These areas should have their insulation excavated back to a zone of good adhesion, the metal examined, and the insulation then repaired in accordance with the manufacturer's recommended procedures.
  - (3) There are presently no regulatory or industry requirements for insulation to be periodically removed to allow visual examination of the P/V. Areas that often suffer separation are those surrounding view ports, areas surrounding pipe connections that transmit vibration to the P/V, and any projection in the upper portion of the P/V where rain or condensation normally contact the P/V.
- c. How to look. Two critical factors of an inspection are illumination and accessibility. There must be sufficient light to allow a thorough examination of all welds and plate surfaces. Bright illumination is necessary for all visual examinations.
- (1) If access to the internal areas is limited to small "inspection openings," a flashlight beam directed through such openings may not provide sufficient illumination for examination. When this occurs, other types of lighting can be used, e.g., flexible lights, borescopes, etc. If the P/V is equipped with a manhole the inspector should be able to get inside, close enough to scrutinize all internal areas.
  - (2) The P/V must be clean enough to allow a thorough examination of all surfaces; the presence of water, grit, or other matter inhibits examination.
  - (3) If the inspector cannot satisfactorily see the area of concern with a bright light directed at the area being examined, a satisfactory internal examination cannot be conducted. In this case, the vessel should be tested by means acceptable to the OCMI to satisfy the periodic inspection requirement.

**NOTE:** A marine inspector must complete a satisfactory internal examination of a P/V before that inspector is authorized to exempt the vessel P/V from hydrostatic testing in accordance with 46 CFR 61.10-5(b).

**SECTION B: DOMESTIC INSPECTION PROGRAMS****CHAPTER 1: INSPECTION OF VESSELS FOR CERTIFICATION**

For any vessel P/V which is constructed in such a way so as to restrict or limit visual accessibility to internal areas of interest to an inspector, in lieu of an internal exam, or when deemed necessary by the attending inspector, a hydrostatic testing or a suitable alternative acceptable to the OCMI mandated by regulation and prudent from an operational standpoint.

**NOTE:** Certain precautions are necessary when an inspector is going to enter a P/V. If the P/V has suffered heavy rusting there may be dangerously low levels of oxygen inside. Similarly, if the P/V has carried a hazardous substance or has been cleaned with a product that can affect a person's health, the P/V should be cleaned, vented, and certified safe for entry prior to doing an internal inspection.

- d. Alternatives. No P/V must be hydrostatically tested except when a defect is found that the marine inspector's believes may affect the safety of the P/V. In this case, the P/V should be hydrostatically tested at a pressure of 1 1/4 times the maximum working pressure (see 46 CFR 61.10-5 for specific guidance).
- (1) Nondestructive Testing (NDT) methods can be authorized as a substitute for the required hydrostatic test. A plan to employ NDT should be discussed with the cognizant OCMI.
  - (2) The methods used must provide examinations of all welds and high stress areas as well as thickness gauging of the lower portion of the P/V. Usually this will include shear wave ultrasonic procedures for crack detection in welds or the shell (high stress areas adjacent to the heads), and standard compression wave procedures for thickness gauging.
  - (3) The amount and type(s) of NDT used must satisfy the OCMI, the test action(s) should be witnessed by a Coast Guard inspector, and the details of the test should be appropriately noted in the inspection record. Items to be considered when evaluating the plan include the P/Vs age, service, conditions of operation, and examination history, especially the methods used and results of past inspections.

## SECTION B: DOMESTIC INSPECTION PROGRAMS

## CHAPTER 1: INSPECTION OF VESSELS FOR CERTIFICATION

- (4) The use of NDT in lieu of hydrostatic testing may be appropriate when there is a question of compatibility between the water and the working fluid or interior coatings. Additionally, the OCMI may accept NDT in lieu of hydrostatic testing when the working fluid cannot be used for the test because of personnel hazards or flammability (see 46 CFR 61.10-5(f) and (h)) and when the weight of the water used during the test cannot be safely supported by the P/Vs substructure.

**NOTE:** Backing strips (rings) and butt welded joints with one plate edge offset (see UW 13.1(k) of the ASME Code) may prevent adequate interpretation of NDT.

- e. Problems found during visual exams. If deterioration affecting the strength of the heads, shell, or welds, or evidence of a fracture is found, the extent of the problem should be determined by NDT so that repairs can be made, if possible.
- (1) If there is doubt about a condition, NDT should be used to confirm that a problem exists. Whenever possible, a 125 percent MAWP hydrostatic test should be conducted to determine the suitability of a P/V for continued service.
  - (2) If a condition requires repair, it may be necessary to remove the P/V from service until the problem has been corrected. Repairs of P/Vs should be made only as allowed by 46 CFR Part 59 and the ASME Code. Weld procedure information and similar guidance for repairs are available through Commandant (G-MOC) and the MSC.
  - (3) Additional NDT and a hydrostatic test should be required for any P/V after repairs have been completed. The test pressure should be the same as that required by the Code at original construction: 150 percent MAWP for Section VIII, Division 1 or 125 percent MAWP for Division 2. Foreign-built P/Vs that have been accepted with design safety factors less than 4:1 should have a test pressure specified by the Coast Guard as noted above.
- f. Hydrostatic test. A hydrostatic test at a pressure equal to 125 percent of the MAWP subjects the P/V to a greater load than it will be exposed to in normal operation, but that it is reasonable to assume the P/V can withstand under ordinary conditions.
- (1) The test pressure should be applied for a sufficient period of time to allow the load to act on any defect. For air receivers, a period of 5 to 10 minutes is normally adequate. If the P/V has developed a crack or has suffered deterioration, the hydrostatic test will be proof of its present condition. Simply stated, if the P/V under test pressure does not rupture, then it can be assumed that it is acceptable for continued service. If the P/V fails while under hydrostatic pressure, the load will be quickly relieved as the water vents through any resulting fracture.

**SECTION B: DOMESTIC INSPECTION PROGRAMS****CHAPTER 1: INSPECTION OF VESSELS FOR CERTIFICATION**

- (2) In some special circumstances, the appropriate test pressure to satisfy the periodic testing requirements is less than 125 percent of the P/V's MAWP. Many foreign-built P/Vs and some domestically-built P/Vs, such as those built to ASME Section VIII, Division 2 specifications, do not meet the allowable stress criteria of ASME Section VIII, Division 1. Instead, they are designed for higher allowable stresses and for this reason are allowed to be tested at a pressure designated by the Coast Guard during the plan review process. This fact may not always be obvious and marine inspectors should carefully review the P/V's data plate to determine the appropriate test pressure.
- (3) Hydrostatic leak tests for P/Vs used for the storage of air or similar compressible gases require the P/V to be depressurized and then filled with water.
- (a) In order to properly fill the P/V with water, it must be vented at its highest point. The relief valve must be removed and its opening plugged tightly. All other connections to the P/V must be closed tight or removed and plugged. The inspector should trace the water source upstream from the P/V to verify supply, and should also verify water pressure in the P/V. This is normally accomplished with a pressure gauge installed on the P/V.
- (b) A word of caution is offered against the use of very cold water as the test fluid. In rare instances, with water at temperatures near freezing, embrittlement can result and cause failure of welds during a test. The test fluid should be no less than 60°F, if possible.
- (c) After the pressure has been increased to 125 percent MAWP, the supply should be secured and the pressure held for a period of time sufficient to determine that there are no leaks. During this time the inspector should examine all the exterior surfaces of the P/V, with special attention given to the welds and their heat affected zones of all nozzles, manways, and similar openings.
- g. Other test considerations. The regulations in 46 CFR 197.462(b) and (d) require periodic pneumatic and hydrostatic tests of pressure vessels for human occupancy (PVHOs) and contain guidelines for these tests. Whenever a compressed gas leak test or pneumatic overpressure test is performed, certain additional safeguards should be employed. The regulations include a general requirement for suitable precautions for these tests, such as ensuring that the P/V is substantially bolted down to a firm foundation; conducting the test in a remote location (or, requiring all persons not involved with the test to leave the area until the test has been completed); and conducting the test with the P/V behind some form of a barrier or substantial structure, if possible. If the P/V is a multi-lock chamber, each lock should be pressurized separately.



**SECTION B: DOMESTIC INSPECTION PROGRAMS****CHAPTER 1: INSPECTION OF VESSELS FOR CERTIFICATION**

- h. Intervals for testing. Each tank must be subjected to the tests and inspections described in 46 CFR 38.25. Intervals for internal examinations and hydrostatic tests for Pressure Vessel Type Cargo Tanks (PVCTs) are to be computed from the date of the last credit internal examination or hydrostatic test. It is not intended that extensions for testing intervals be granted except in the most unusual circumstances. All requests by industry for extensions of internal examination or hydrostatic test intervals of PVCTs should be forwarded to Commandant (CG-CVC) with an endorsement by the OCMI.

---

**P. INSPECTION OF LIFESAVING SYSTEMS**

---

**1. Introduction**

Each Title 46 CFR subchapter on inspected vessels requires that inspections for certification include tests and inspections of the lifesaving equipment. The inspections and tests in this section are designed to verify that the equipment, as installed on the vessel, complies with regulations in 46 CFR Chapter I and, where applicable, the International Convention for the Safety of Life at Sea (SOLAS).

- a. Conditions of approval. The installation of each lifeboat, rescue boat, liferaft, and their respective launching appliance must meet any special conditions of its approval. Any such conditions are identified on the equipment's Certificate of Approval. Check approval records in MISLE. The contents of the approval certificate and its status (approved, expired, former may use, or former may not use) may also be found at <http://cgmix.uscg.mil>
- b. Excess lifesaving equipment. Excess lifesaving equipment carried aboard inspected vessels must be of approved types and kept in good operating condition.
- c. Repair, modification, and special inspection procedures. See MSM Volume II, Material Inspection, COMDTINST M16000.7 (series), Chapter C2 and various NVICs for more detailed information on repairs, modifications, and special inspections of lifesaving equipment. Under current SOLAS requirements (Regulations III/20 and III/36), maintenance instructions for all lifesaving equipment are required on board and equipment must be maintained according to the instructions.
- (1) Some instructions may state or imply that certain inspections and repairs must be performed by a manufacturer's representative. This is enforceable when it comes to the servicing of inflatable liferafts, servicing of non-disposable hydrostatic release units, and permanent repairs to inflated rescue boat components, all of which must be done by a Coast Guard-approved facility.

## SECTION B: DOMESTIC INSPECTION PROGRAMS

**CHAPTER 1: INSPECTION OF VESSELS FOR CERTIFICATION**

- (2) The inspector should be satisfied that other inspections and repairs are carried out by competent persons. In some cases, a manufacturer's representative may be the only available choice.
- d. Loading procedures. Many of the tests in this section for launching appliances require the boat to be loaded or overloaded with deadweight. Adequate safety precautions should be taken during loading of the boat. Personnel should not be permitted to be used in the tests that load the boat to or beyond rated capacity, except as is absolutely necessary to load or unload the boat, or perform some part of the test once the boat has reached the water.
- (1) Open lifeboats are required to have engine boxes that are watertight up to the level of the cover. Although not recommended, the owner or shipyard may elect to load an open boat by filling it with water. (See NVIC 6-81 for details on using water for this purpose and use of a test waterline.)
- (2) Enclosed and partially enclosed boats do not normally have watertight engine boxes and cannot be flooded. Any weights that can be properly distributed can be used.
- (3) Experience has shown that bags of sand or other fine material inevitably leak and create a cleanup problem. Bags of lead shot with carrying handles are more efficient and less likely to be a problem.
- (4) Large water containers can be used. Large capacity water bags may be difficult to use successfully. These bags, without baffles or compartments, allow a free surface effect that can destabilize the lifeboat, especially if the bags are at or above seating level, raising the center of gravity. This method may also not provide for a thorough distribution of weight. Smaller bags or buckets of a capacity easily handled should be used and distributed uniformly, including the area in way of the keel.
- e. Weight conditions "A" and "B." Lifeboats have two weights stamped on their approval plates.
- (1) The condition "A" weight is the empty boat without equipment and fuel.
- (2) The condition "B" weight is condition "A" plus the weight of all equipment, fuel and the number of persons for which the boat is approved. The current standard weight used to compute the "B" weight is 181.5 lbs (82.5 kg) per occupant for lifeboats on cargo ships and 165 lb (75 kg) per occupant on passenger ships. For lifeboats installed before July 1, 2010, use the weights marked A and B on the lifeboat's permanent placard, which would be based on 165 lbs per occupant for all lifeboats.

## SECTION B: DOMESTIC INSPECTION PROGRAMS

## CHAPTER 1: INSPECTION OF VESSELS FOR CERTIFICATION

f. Definitions:

- (1) Auxiliary launching systems consisting of a winch and davit arrangement are provided for free-fall lifeboats for use in those cases where it may be unsafe to launch the boat in free-fall. These systems must meet many of the same requirements as a conventional davit and winch.
- (2) Fleet angle, referring to a wire rope leading to a winch drum, means the angle included between an imaginary line from the lead sheave perpendicular to the axis of the drum, and the line formed by the wire rope when led from the lead sheave to either extremity of the drum. See figure P-1 below.

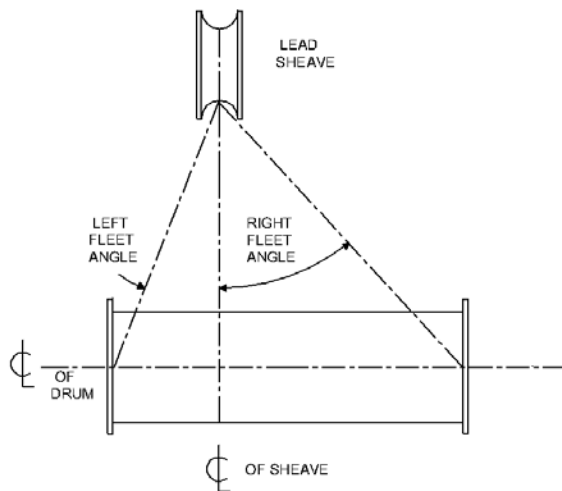

## SECTION B: DOMESTIC INSPECTION PROGRAMS

## CHAPTER 1: INSPECTION OF VESSELS FOR CERTIFICATION

Figure P-1: Fleet angle

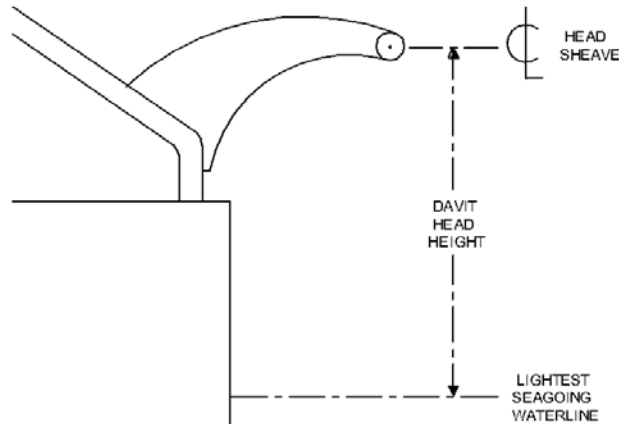

Figure P-2: Representation of davit head height for calculating lowering speed

- (3) Free-fall launching systems launch a survival craft by allowing it to fall from its stowage position into the sea, with persons on board. Most free-fall systems include a ramp that the survival craft slides down before it begins its free-fall. Special seating, hull design, and fall trajectory provide for the safety of those on board, and also ensure that the craft moves away from the vessel when it enters the water, whether or not the engine has been started.
- (4) Inflatable Buoyant Apparatus (IBAs) are similar to inflatable liferafts, except they do not have canopies. Larger IBAs can be used either side up. IBAs must be serviced in the same way as inflatable liferafts. On vessels, IBAs can be substituted for conventional life floats and buoyant apparatus. With the approval of the Commandant (CG-CVC), IBAs may be allowed to be substituted for inflatable liferafts on inshore waters.
- (5) Marine evacuation systems consist of a slide or chute, an inflatable platform, and associated survival craft, designed to rapidly transfer large numbers of persons from an embarkation station directly to the survival craft or to the platform for subsequent embarkation into the survival craft.

## SECTION B: DOMESTIC INSPECTION PROGRAMS

## CHAPTER 1: INSPECTION OF VESSELS FOR CERTIFICATION

**2. Initial Inspections**

The following inspections are intended for a vessel undergoing its initial inspection for certification. The applicable tests should also be conducted whenever new lifesaving equipment is installed on any vessel, or whenever any item of lifesaving equipment is structurally repaired, altered, or undergoes any other major repair which could affect its performance. This subpart is written on the assumption that equipment on a vessel undergoing its initial inspection is new.

- a. Davit and winch launching systems for lifeboats, including auxiliary launching systems for free-fall lifeboats. (See MSM Volume II, Material Inspection, COMDTINST M16000.7 (series), Chapter C2 for detailed information on certain situations concerning boat handling equipment.)

- (1) Preparation for launching.

- (a) Procedure. The inspector must determine the time required for two crew members to prepare the boat for launching. Time starts with the two crew members at the boat launching station, and the boat stowed as it normally would be when the vessel is at sea. Preparation is complete once a launching crew (at least three persons) is on board and ready for launch.

- (b) Acceptance criteria. The time to prepare the boat for launching must be 5 minutes or less.

- (2) Light load. Operating the launching system at light load demonstrates that the mass of the boat is sufficient to overcome the frictional resistance of the winch, falls, sheaves, blocks, and associated gear. It verifies that the minimum lowering speed can be achieved in this condition. For boats with a hydrostatic lock on the release mechanism, it verifies that the lock operates at the lowest operational hydrostatic pressure. This test can generally be completed quickly, since no special loading is required for a fully equipped boat.

- (a) Procedure.

[1] The boat should approximate its condition "A" weight for this test, with added weight of equipment and fuel on board. Precise loading and load measurement is not necessary, however. In addition, one person may be on board to operate an onboard winch brake control or the release mechanism. If additional personnel are needed to complete the test and to recover the boat, they may board when the boat reaches the water.

**SECTION B: DOMESTIC INSPECTION PROGRAMS****CHAPTER 1: INSPECTION OF VESSELS FOR CERTIFICATION**

- [2] Release the gripes, if necessary. Tricing, frapping, and/or bowing gear do not need to be used for this test if they are not needed.
- [3] Lower the boat by releasing the winch brake. If the winch brake is arranged for control from within the boat, a person on board the boat should operate the winch brake control.
- [4] Determine lowering speed by timing the boat as it drops through a measured distance marked on the side of the vessel or on the falls, or by any other reliable means. The speed measurement should be taken only after the winch has accelerated to full-governed speed.
- [5] Launch the boat into the water using the normal launching procedure as specified in the ship's training manual and the equipment markings.
- [6] Recover the boat with the winch. Anyone on board the boat should disembark when it reaches deck level. No one should be on board the boat when the weight of the davit is taken up by the winch, and the davit moves into its stowage position. This is when most fall and fall attachment failures occur.

**SECTION B: DOMESTIC INSPECTION PROGRAMS****CHAPTER 1: INSPECTION OF VESSELS FOR CERTIFICATION****NOTE:**

Release mechanisms approved under approval series 160.133 and installed prior to January 1, 2013 will typically have a hydrostatic lock that allows the hooks to be released only once the boat is in the water. However, all lifeboats approved under approval series 160.135 after January 1, 2013 will have a hydrostatic interlock or some other means to ensure the lifeboat is waterborne before the release mechanism can be activated. With the keel of the boat at or just in the water and tension on the falls, it should be verified that the hydrostatic lock prevents operation of the release mechanism. Then with the boat lowered into the water, the hydrostatic lock should open and permit operation of the release mechanism.

An automatic release mechanism (approval series 160.170) is sometimes used on a boat or survival capsule with a single fall launching system. Once set or cocked, these devices release as soon as tension is off the fall. Set these devices for automatic operation for this test. If a person will be on board the boat as it is lowered, that person should set the release mechanism for automatic operation just before the boat reaches the water.

Some older style release mechanisms such as “Rottmer” gear, typically still found in open lifeboats, will release the boat from the falls whenever the release handle is moved, whether the boat is in the water or not. Persons in command of the boat and operating these mechanisms must fully understand the danger of serious injury or death resulting from premature operation.

Release the boat from the falls using the on-load release mechanism control as the boat reaches the water. The keel of the boat should be at or in the water, but there should still be tension on the falls when the release mechanism is operated. A release handle safety pin, if fitted, should not be removed until the boat is in position for release.

(b) Acceptance criteria.

[1] There must be no deformation of or damage to the launching appliance or its connections to the vessel.

## SECTION B: DOMESTIC INSPECTION PROGRAMS

## CHAPTER 1: INSPECTION OF VESSELS FOR CERTIFICATION

- [2] Except for free-fall lifeboat auxiliary launching systems, the lowering speed for systems with winches (160.115 approval series) must be at least

$$S = 0.7*(0.4 + (0.02 H))$$

where S is the speed of lowering in m/s, and H is the height in meters from davit head to the waterline at the lightest seagoing condition. For the purposes of this calculation, H must not be greater than 30, regardless of the actual height of the davit head.

In English units, the formula is

$$S = 0.7*(79 + (1.2 H))$$

where S is in ft/min and H is in ft, with H not greater than 99.

- [3] Auxiliary launching systems for free-fall lifeboats must safely and successfully lower the lifeboat. No minimum speed applies.
- [4] The lowering speed for systems with winches approved only under the 160.015 approval series must be at least 40 ft/min (0.2 m/s), except that in the case of winches designed for passenger vessel “emergency lifeboats”, the speed must be at least 60 ft/min (0.3 m/s). The carriage requirements for two lifeboats “for use in an emergency” apply to SOLAS passenger vessels built prior to July 1, 1986, pre-dating the carriage requirements of SOLAS rescue boats incorporated in the 1983 SOLAS. See SOLAS '74 unamended, Chapter III, Part B, Regulation 27.

**NOTE:** A winch in the 160.115 approval series may be used to replace a winch in an older davit installation where the higher speed requirements do not apply. In this case, the winch may be set up to meet the speed requirement in this paragraph.



**SECTION B: DOMESTIC INSPECTION PROGRAMS****CHAPTER 1: INSPECTION OF VESSELS FOR CERTIFICATION**

- [5] The brake must be a deadman type, always applied unless the operator holds the control handle or mechanism in the position to lower the boat. If the operator releases the brake handle/mechanism, the handle/mechanism returns to the stop position, thus applying the brake and stopping the boat. No additional force is permitted.
- [6] Each winch drum must be arranged so the fall wire winds onto the drum in a level wrap. There must be no more than one layer of wire on the drum when the davit is in stowed position, except that if the maximum fleet angle is not more than 4°, two layers of wire are acceptable on a grooved drum. Winches must be demonstrated to wind the falls evenly on and off the drum, regardless of whether the drum is grooved or smooth. The fleet angle must not exceed 8° in any winch installation.
- [7] For a multiple fall system, the falls must wind off the drums at the same rate when lowering. The falls must wind onto the drums evenly and at the same rate when hoisting.
- [8] For launching appliances arranged for control from within the boat, there are two basic types of control.
- aa. One of these types uses a control wire that pays out as the boat lowers. The control wire must properly operate the winch brake throughout the launching sequence. There must be sufficient length of control wire available inside the boat to operate the winch brake until the boat is released from the falls.
- bb. The other type is a pull-and-go system. An operator in the boat pulls a control lever or handle on the launching appliance that is accessible from a position on board the boat. Once the control is activated, it holds the brake control in the lower position, until a crew member on deck returns it to stop.
- [9] The release mechanism must open all hooks simultaneously and release the boat into the water in the intended manner.
- [10] Except for free-fall lifeboat auxiliary launching systems, survival craft installations approved under approval series 160.115 and 160.132 must be capable of launching the survival craft under unfavorable conditions of trim of up to 10° and with the vessel listed up to 20° either way. For other installations, the trim requirement is 10°, but the list requirement is 15°. Prototype launching systems are tested at these extremes prior to approval. It will not normally be possible to test launching systems installed on a vessel at these extremes, but the inspector

## SECTION B: DOMESTIC INSPECTION PROGRAMS

## CHAPTER 1: INSPECTION OF VESSELS FOR CERTIFICATION

should verify that nothing about the installation would appear to impede launching under these conditions.

- (3) 10 percent overload. The 10 percent overload test demonstrates that the launching system can safely launch a fully loaded boat with a 10 percent margin for overloading.

(a) Procedure.

- [1] The boat must be in its embarkation position. Tricing pendants, if any, must be disconnected. The boat should be held alongside the ship during loading by means of the installed frapping, and/or bousing gear.
- [2] Load the boat so that its total weight is 110 percent of the condition "B" weight shown on its data plate. Hold the boat in position for at least 10 minutes and check for deformation, especially at davit and winch foundations and other load-bearing members.
- [3] Lower the boat using the normal lowering procedure, using the on-deck winch control position.
- [4] Determine lowering speed by timing the boat as it drops through a measured distance marked on the side of the vessel or on the falls, or by any other reliable means. The speed measurement should be taken only after the winch has accelerated to full governed speed.
- [5] After the boat passes through the measured distance, stop lowering by releasing the winch brake control. Then alternately release and apply the brake so the boat stops at approximately 2 m (6 ft) intervals. Complete at least three start-stop cycles. The lowering operation should be carefully planned, so that the boat will not have to be raised to complete the start-stop cycles. Most winches will not be capable of raising the loaded boat.
- [6] Stop lowering just as the boat reaches the water. The keel of the boat should be at or in the water, but there should still be tension on the falls. Release the boat from the falls using the on-load release mechanism control. Release mechanisms with a hydrostatic interlock will require use of the emergency override device to permit on-load release. For lifeboats installed after January 1, 2013, the interlock override will include special mechanical protection that must be deliberately destroyed, e.g. by breaking a protective glass or translucent cover. The restoration of the release mechanism in these cases should be planned for, and may require a service technician.

## SECTION B: DOMESTIC INSPECTION PROGRAMS

## CHAPTER 1: INSPECTION OF VESSELS FOR CERTIFICATION

[7] Unload the boat, recover it with the winch, and return it to its stowed position. Observe operation of the limit switches as the davit approaches the stowed position. Anyone on board the boat should disembark when the boat reaches deck level. No one should be on board the boat when the weight of the davit is taken up by the winch, and the davit moves into its stowage position. This is when most fall and fall attachment failures occur.

(b) Acceptance criteria.

- [1] There must be no deformation of or damage to the launching appliance or its connections to the vessel.
- [2] Except for free-fall lifeboat auxiliary launching systems, the lowering speed for systems with winches (160.115 approval series) must be at least:

$$S = 0.4 + (0.02 H)$$

where S is the speed of lowering in m/s, and H is the height in meters from davit head to the waterline at the lightest seagoing condition. For the purposes of this calculation, H must not be greater than 30, regardless of the actual height of the davit head.

In English units, the formula is

$$S = 79 + (1.2 H)$$

where S is in ft/min and H is in ft, with H not greater than 99.

- [3] Auxiliary launching systems for free-fall lifeboats must safely and successfully lower the lifeboat, but no minimum speed applies.
- [4] The lowering speed for systems with winches (160.115 approval series), including auxiliary systems for free-fall lifeboats, must not exceed 1.3 m/s (256 ft/min).
- [5] The lowering speed for systems with winches approved only under the 160.015 approval series must not normally exceed 120 ft/min (0.6 m/s). The lowering speed for winches designed for passenger vessel emergency lifeboats must not normally exceed 160 ft/min (0.8 m/s). Check certificates of approval, or approval records in MISLE or CGMIX for approved deviations from these requirements.

## SECTION B: DOMESTIC INSPECTION PROGRAMS

## CHAPTER 1: INSPECTION OF VESSELS FOR CERTIFICATION

**NOTE:** A winch in the 160.115 approval series may be used to replace a winch in an older davit installation where the higher speed requirements do not apply. In this case, the winch may be set up to meet the speed requirement in this paragraph.

- [6] The brake must be a deadman type, always applied unless the operator holds the control handle or mechanism in the position to lower the boat. If the operator releases the brake handle/mechanism, the handle/mechanism returns to the stop position, thus applying the brake and stopping the boat. No additional force is permitted.
- [7] The action of releasing the winch brake control must bring the boat to a stop within 1 m (39 in). No additional force on the winch brake control is permitted. The brake action must be smooth and positive.
- [8] Each winch drum must be arranged so the fall wire winds onto the drum in a level wrap.
- [9] For a multiple fall system, the falls must wind off the drums at the same rate when lowering. The falls must wind onto the drums evenly and at the same rate when hoisting.
- [10] For launching appliances arranged for control from within the boat, the untended control wire must feed out properly with the boat. The winch brake operation must not be affected by the mass of the fully extended control wire.
- [11] The release mechanism must open all hooks simultaneously and release the boat into the water.
- [12] The limit switches must disconnect the winch power source 0.3 m (12 in) or more before the davit reaches its fully stowed position.
- (4) Exposed wet brake. Conduct this test if any winch brake surface is exposed to the weather.
- (a) Procedure. Thoroughly wash down the exposed brake surfaces with water. Repeat the 10 percent overload test described in P.2.a.(3) above while the brake surfaces are still wet.
- (b) Acceptance criteria. The brake must stop the winch when the brake surface is wet, but the 1 m stopping distance requirement does not apply.
- (5) Launching underway. This test is intended to demonstrate that the boat can be launched satisfactorily when the vessel is underway at 5 knots, and also that the boat

## SECTION B: DOMESTIC INSPECTION PROGRAMS

## CHAPTER 1: INSPECTION OF VESSELS FOR CERTIFICATION

can be launched satisfactorily when the vessel is moored in a current. This test should normally be completed during the trial trip. The test may be waived if the builder, owner, or equipment manufacturer can provide evidence that such a test has been successfully completed for the boat/davit/winch combination on a sister vessel. For the purposes of this test, a sister vessel is one which is generally of the same size and hull form, and where the launching position, including height above the water line, is the same.

- (a) Procedure. Launch one boat of each type on board with only the required operating crew on board and the vessel proceeding at a speed of approximately 5 knots. No special loading of the boat is required. Use the manufacturer's recommended launching procedure.
  - (b) Acceptance criteria. The boat must not give any indication that it is unstable or out of control during the launching procedure. The boat's painter release device must operate as intended.
- b. Free-fall lifeboat launching systems. Free-fall lifeboat and launching system installation tests are conducted with the vessel on an even keel at its lightest seagoing draft. The tests described in this section may be conducted in any order appropriate to facilitate test loading.
- (1) Light load.
    - (a) Procedure.
      - [1] The boat should be arranged for launching by a launching crew on board the boat. Although not required, trial launchings would normally be carried out by the manufacturer's representative before the inspection for certification begins.
      - [2] The boat should approximate its condition "A" weight for this test, with added weight of equipment and fuel on board. Precise loading and load measurement is not necessary. In addition, the minimum launching crew should be on board to operate the on-board launching control.
      - [3] The launching crew should launch the boat in free-fall by one of the two independent activation systems for the release mechanism which must be operated from inside the lifeboat. The boat should then be retrieved and examined with respect to the acceptance criteria below.

## SECTION B: DOMESTIC INSPECTION PROGRAMS

## CHAPTER 1: INSPECTION OF VESSELS FOR CERTIFICATION

(b) Acceptance criteria.

- [1] There must be no deformation of or damage to the launching appliance or its connections to the vessel.
- [2] There must be no deformation of or damage to any seat or seat mounting in the lifeboat.
- [3] There must be no cracks or other structural damage to the hull of the lifeboat or any other structurally important part of lifeboat. Cracks in structural members of a free-fall lifeboat indicate that the structure must be replaced.
- [4] There must be no cracks in non-structural members that could break loose during a free-fall launching.
- [5] The free-fall release mechanism must operate properly and release the boat from the launching appliance.
- [6] The launching system must operate smoothly, must launch the boat into the water at the intended angle, and must not show any evidence of improper operation.
- [7] The lifeboat must not show any evidence of instability or dangerous characteristics during the launching sequence. Water entry angle will normally be between 40 degrees and 70 degrees from the horizontal. The momentum of the boat should move it away from the vessel after it enters the water.
- [8] There must be no injury to any personnel in the boat attributable to the free-fall performance of the boat.
- [9] If the inspector has reason to believe that the boat is not being launched in a safe and proper manner, the inspector may order that the test be repeated with the boat instrumented with acceleration monitoring equipment. Consult IMO Resolution MSC.81(70) entitled, Revised recommendation on Testing of Life-saving Appliances” Part 1/6.17 for information on measuring and evaluating acceleration forces. The monitoring and analysis should be done by, or under the supervision of, an independent laboratory accepted by the Commandant (CG-ENG-4) for this purpose. The test results are compared with the approval test data to determine whether or not the boat is being launched in a safe and proper manner.

(2) 10% overload test.

## SECTION B: DOMESTIC INSPECTION PROGRAMS

## CHAPTER 1: INSPECTION OF VESSELS FOR CERTIFICATION

- (a) Procedure. Load each seat in the lifeboat with 82.5 kg to 100 kg (181.5 lbs to 220 lb) of deadweight properly secured in place to simulate the weight of one person.
- [1] Add additional weights using equipment lockers, if necessary, to bring the total boat weight to 1.1 times the condition "B" weight.
- [2] The launching crew should launch the boat in free-fall by one of the two independent activation systems for the release mechanism which must be operated from inside the lifeboat. The boat should then be retrieved and examined with respect to the acceptance criteria outlined for the light load test above.
- (3) Conduct this test if the launching system incorporates an adjustable ramp.
- (a) Procedure.
- [1] Load each seat in the lifeboat with 82.5 kg to 100 kg (181.5 lb. to 220 lb.) of deadweight properly secured in place to simulate the weight of one person. Add additional weights to bring the total boat weight to 1.2 times the condition "B" weight.
- [2] Move the ramp throughout its intended range of operation.
- [NOTE: The 1.2 times condition "B" loading is derived from IMO Resolution MSC.81(70) Part 2, Paragraph 6.1.13. It may be advantageous to conduct this test, remove some of the weight from the boat, and then conduct the 10% overload test.]
- (b) Acceptance Criteria.
- [1] The ramp shall be able to be satisfactorily adjusted to its intended operating positions.
- [2] The ramp shall move from the stowed position to launching position using only gravity or stored mechanical power which is independent of the vessel's power supplies.

## SECTION B: DOMESTIC INSPECTION PROGRAMS

## CHAPTER 1: INSPECTION OF VESSELS FOR CERTIFICATION

- c. Davits And Winches For SOLAS Rescue Boats and fast rescue boats. Test and inspect launching systems for SOLAS rescue boats in the same way as those for lifeboats under Section P.2.a, in addition to the following test for recovery speed. This test applies to launching systems for boats approved and used solely as rescue boats, as well as those which hold dual approval as lifeboats and rescue boats, and which are designated as the ship's rescue boat(s).
- (1) Procedure.
- (a) Load the boat with a weight equivalent to its full complement of persons and equipment (total boat weight equal to condition "B"). Each occupant is considered to weigh 82.5 kg (181.5 lb), except for rescue boats installed prior to July 1, 2010 where each occupant is considered to weigh 75 kg (165 lbs). The full complement of persons is designated by the manufacturer, and will never be less than six. If the boat is also approved as a lifeboat, its full rescue boat complement will probably be less than the number of persons it can accommodate as a lifeboat.
- (b) Determine hoisting speed by timing the boat as it rises through a measured distance marked on the side of the vessel or on the falls, or by any other reliable means. The speed measurement should be taken only after the winch has accelerated to full governed speed.
- (2) Acceptance Criteria. The hoisting speed must be not less than 0.3 m/s (59 ft/min).
- d. Launching Appliances For Davit Launched Liferafts and inflated rescue boats.
- (1) Light Load. Operating the launching system at light load demonstrates that the mass of the raft is sufficient to overcome the frictional resistance of the winch, falls, sheaves, blocks, and associated gear.
- (a) Procedure.
- [1] Prepare a test load which can be suspended from the automatic release mechanism. The test load shall equal the weight of one of the launching station's liferafts and its equipment, plus 82.5 kg (181.5 lbs) simulating the weight of one person. An inflated davit-launched liferaft carrying a 82.5 kg weight may be used for the test load, but is not required.
- [2] Lower the test weight from the embarkation deck by releasing the winch brake, and "launch" the weight using the normal automatic release procedure. If a non-buoyant test weight is used, the weight is "launched" onto a surface that will support its weight, rather than into the water. If this is not possible, an additional test will need to be devised to test the automatic release mechanism.



## SECTION B: DOMESTIC INSPECTION PROGRAMS

## CHAPTER 1: INSPECTION OF VESSELS FOR CERTIFICATION

- [3] Determine lowering speed by timing the test weight as it drops through a measured distance marked on the side of the vessel or on the fall, or by any other reliable means. The speed measurement should be taken only after the winch has accelerated to full governed speed.
- [4] Recover the fall with the hand-operated quick-return mechanism.
- (b) Acceptance Criteria.
- [1] There shall be no deformation of or damage to the launching appliance or its connections to the vessel.
- [2] The lowering speed for a launching appliance must be at least:  $S = 0.7 (0.4 + (0.02 H))$ , where S is the speed of lowering in m/s, and H is the height in meters from davit head to the waterline at the lightest seagoing condition (See figures P-1 and P-2). For the purposes of this calculation, H shall not be greater than 30, regardless of the actual height of the davit head. (in English units, the formula is:  $S = 0.7 (79 + (1.2 H))$ , where S is in ft/min and H is in ft, with H not greater than 99).
- [3] The lowering speed for systems approved only under the 160.063 approval series shall be at least 40 ft/min (0.2 m/s).
- [4] The brake must always be applied unless the operator, or a mechanism activated by the operator, holds the brake control in the "off" position. The test weight must begin to lower each time the brake is released. No additional force is permitted.
- (c) Each winch drum shall be arranged so the fall wire winds onto the drum in one or two level wraps.
- (d) The automatic release mechanism must open and release the test weight only after the apparatus is set to open automatically and the load of the test weight is off the fall.
- (e) The operation of the hand-operated quick-return mechanism must be smooth, rapid, and easy enough for one person to recover the fall.

## SECTION B: DOMESTIC INSPECTION PROGRAMS

## CHAPTER 1: INSPECTION OF VESSELS FOR CERTIFICATION

(2) 10% Overload.

## (a) Procedure.

[1] Prepare a test load which can be suspended from the automatic release mechanism. The test load shall equal:

$$1.1*(W + M*P) \quad (\text{in kg})$$

$$1.1*(W + M*P) \quad (\text{in lb})$$

where W is the weight of one of the launching station's liferafts and its equipment, M is 75 kg (165 lbs) for passenger vessels or 82.5 kg (181.5 lbs) for all other vessels, and P is the number of persons the liferaft is approved to accommodate. An inflated davit-launched liferaft carrying additional weight may be used for the test load, but is not required.

Alternatively, the test load may be:

$$1.1*SWL$$

where SWL is the least of the three approved working loads for the davit, winch, or automatic release mechanism.

[2] Lower the test weight from the embarkation deck by releasing the winch brake.

[3] Determine lowering speed by timing the test weight as it drops through a measured distance marked on the side of the vessel or on the fall, or by any other reliable means. The speed measurement should be taken only after the winch has accelerated to full governed speed.

[4] After the test weight passes through the measured distance, stop lowering by releasing the winch brake control. Then alternately release and apply the brake so the test weight stops at approximately 2 m (6 ft) intervals. Complete at least three start-stop cycles. The lowering operation should be carefully planned, so that the weight will not have to be raised to complete the start-stop cycles, since it may not be possible to raise the weight with the winch.

[5] "Launch" the weight using the normal automatic release procedure. If a non-buoyant test weight is used, the weight is "launched" onto a surface that will support its weight, rather than into the water. If this is not possible, an additional test will need to be devised to test the automatic release mechanism.

[6] Recover the fall with the hand-operated quick-return mechanism.

## SECTION B: DOMESTIC INSPECTION PROGRAMS

## CHAPTER 1: INSPECTION OF VESSELS FOR CERTIFICATION

## (b) Acceptance Criteria.

- [1] There shall be no deformation of or damage to the launching appliance or its connections to the vessel.
- [2] Except as indicated in [3] and [4] below, the lowering speed for launching appliances must be at least:  $S = 0.4 + (0.02 H)$  where S is the speed of lowering in m/s, and H is the height in meters from davit head to the waterline at the lightest seagoing condition (See figures P-1 and P-2). For the purposes of this calculation, H shall not be greater than 30, regardless of the actual height of the davit head. (In English units, the formula is  $S = 79 + (1.2 H)$  where S is in ft/min and H is in ft, with H not greater than 99.)
- [3] The lowering speed for 160.163 approval series launching appliances must not exceed 1.3 m/s (256 ft/min).
- [4] The lowering speed for systems approved only under the 160.063 approval series shall not exceed 120 ft/min (0.6 m/s).
- [5] The brake must always be applied unless the operator, or a mechanism activated by the operator, holds the brake control in the "off" position. The test weight must begin to lower each time the brake is released. No additional force is permitted.
- [6] The action of releasing the winch brake control must reapply the brake and bring the test weight to a stop within 1 m (39 in). No additional force on the winch brake control is permitted. The brake action must be smooth and positive.
- [7] Each winch drum shall be arranged so the fall wire winds onto the drum in one or two level wraps.
- [8] The automatic release mechanism must open and release the test weight only after the apparatus is set to open automatically and the load of the test weight is off the fall.
- [9] The operation of the hand-operated quick-return mechanism must be smooth, rapid, and easy enough for one person to recover the fall.

## SECTION B: DOMESTIC INSPECTION PROGRAMS

## CHAPTER 1: INSPECTION OF VESSELS FOR CERTIFICATION

- (3) Exposed Wet Brake. Conduct this test if any winch brake surface is exposed to the weather.
- (a) Procedure. Thoroughly wash down the exposed brake surfaces with water. Repeat the 10% overload test under Section 6.P.2.d.(2) while the brake surfaces are still wet.
- (b) Acceptance Criteria. The brake must stop the winch when the brake surface is wet, but the 1 m stopping distance requirement does not apply.
- (4) Simulated Towing Strain. Test the automatic release mechanism to determine that it can be manually released under a towing strain.
- (a) Procedure.
- [1] Use the 10% overload test weight (Section P.2.d.(2)).
- [2] Apply a horizontal force to a floating test weight, or simulate a towing strain on a floating liferaft by applying a horizontal force to the non-buoyant test load. A sufficient force should be applied to the fall to bring it to an angle of approximately 5 degrees from vertical. The horizontal force may be applied by a motor vessel, a vehicle, manually, or any other appropriate means.
- [3] A non-buoyant test load should be just above the surface, or just touching the surface, but with tension remaining on the fall.
- [4] First, set the automatic release mechanism to the automatic position, then operate the release manually.
- (b) Acceptance Criteria.
- [1] The automatic release mechanism must not open with tension on the fall and the release set to the automatic position.
- [2] The release mechanism must release the test load when manually operated by one person.
- e. Lifeboats And SOLAS Rescue Boats.
- (1) Coast Guard inspectors have traditionally examined every Coast Guard approved lifeboat at the factory. This system has been replaced by a system of factory production inspections by accepted independent labs, usually classification societies. Refer to the lifeboat or rescue boat's nameplate for the name of the lab that oversaw construction. The same lab must also be listed on the boat's

**SECTION B: DOMESTIC INSPECTION PROGRAMS****CHAPTER 1: INSPECTION OF VESSELS FOR CERTIFICATION**

approval certificate. Refer to MISLE to CGMIX for the boat's certificate information if not available on board the vessel. Therefore, this operational test during the initial inspection for certification is or will be the Coast Guard's only opportunity to examine individual boats before they go into service on U.S. vessels.

(a) Lifeboats And SOLAS Rescue Boats. Operate each lifeboat and rescue boat in the water for at least two hours. The Coast Guard inspector does not need to be aboard the boat for the full two hours.

[1] During this time, the propulsion system is operated both forward and astern. At least one hour of this running time is with the propulsion system operating at full speed.

[2] Operate each boat system, such as any powered bilge pump, or the water spray system that are required on tanker lifeboats.

[3] Check all engine starting systems for proper operation. Lifeboats (approval series 160.135) and SOLAS rescue boats (approval series 160.156) must either have a manual starting system or a power starting system with two rechargeable energy sources, each capable of starting the engine.

Note: Existing lifeboats approved only under the 160.035 approval series must have a manual starting system, unless they have been retrofitted to meet SOLAS requirements. New installations of 160.035 lifeboats are only allowed as replacement-in-kind on existing vessels and offshore facilities. See 46 CFR 199.10(i). Check the list of accepted engines on CGMIX at <https://cgmix.uscg.mil/Equipment/> to determine the required engine starting system. The engine(s) with which the lifeboat or rescue boat was approved are listed on the boat's approval certificate. See section P.3.e.(8) if problems are suspected with hydraulic engine starting systems.

[4] Check the pressure on any air supply system installed on a tanker lifeboat, but testing the air supply system should not be necessary on a new boat.

[5] Compare compass readings with several known bearings in different directions.

[6] Operate the emergency steering system in totally enclosed lifeboats.

(b) Hand-Propelled Lifeboats. Operate each hand-propelled lifeboat in the water for period of time sufficient to determine that it operates properly

**SECTION B: DOMESTIC INSPECTION PROGRAMS****CHAPTER 1: INSPECTION OF VESSELS FOR CERTIFICATION**

both forward and astern. Compare compass readings with several known bearings in different directions.

(c) Oar-Propelled Lifeboats. New installations of oar-propelled lifeboats are only allowed as replacement-in-kind on existing vessels. Operate each oar-propelled lifeboat in the water with a crew sufficient for each oar and the tiller. Compare compass readings with several known bearings in different directions.

(d) Acceptance Criteria.

[1] The boat and each of its systems must operate properly without overheating or being damaged.

[2] The boat must not have any evident leakage through the hull or around any through-hull fitting.

[3] If compass errors exceed 10 degrees, the compass should be adjusted using the compensating mechanism to minimize the errors. A compass deviation card should be prepared and mounted on or near the compass.

[4] In totally enclosed, fire-protected lifeboats, the water spray system sprinkler heads must operate properly and provide a uniform flow of water over the surface of the lifeboat. Hatch and glass gaskets, dogging devices, and other closures should prevent entry of water.

(e) Battery Chargers. Batteries for engine starting and searchlights must have a means for recharging from the ship's power supply at a supply voltage not exceeding 50 Volts which can be disconnected at the boat embarkation station. Solar battery chargers may be an approved equivalent, however, determine that the battery charging systems are functional and in accordance with 46 CFR Subchapter J.

**SECTION B: DOMESTIC INSPECTION PROGRAMS****CHAPTER 1: INSPECTION OF VESSELS FOR CERTIFICATION**

- f. Boats And Davits Not Credited As Lifesaving Equipment. Some vessels by nature of their operation, carry special boats and launching equipment in addition to those required for lifesaving purposes. Survey launches, personnel boats, workboats, and similar craft are not subject to approval as lifesaving equipment, but should be sufficiently seaworthy for the waters in which they will be used. New boats may meet the applicable requirements of 33 CFR 183, but this is not a requirement if the boat will be used solely for commercial purposes. In this case, only the requirements of 46 CFR Subchapter C apply. Launching equipment for such craft is often intended only to handle an empty boat, with embarkation and debarkation taking place with the boat in the water. However, if the launching equipment results in personnel being suspended over water on wires, the launching equipment and attachments should be checked by a 10% overload test, similar to that for lifeboat and rescue boat launching appliances. After the test, the boat attachments should be visually checked for cracking and distortion. Appropriate data plates should be installed on both the winch and davit.
- g. Hydrostatic Release Units. Check each hydrostatic release unit used in an item of lifesaving equipment, including those used in certain 406 MHz satellite EPIRBs. (See NVIC 4-86 for guidelines on installation of hydrostatic release units for survival craft.)
- (1) Disposable Releases. Disposable hydrostatic releases must be marked with their expiration date using the tabs on the label. This must be done when the release is installed.
  - (2) Hidden Installations. Some hydrostatic releases, especially those used on certain EPIRBs, can not be readily seen when the equipment is properly installed. If the servicing date or expiration date on an installed hydrostatic release can not be readily seen, a label should be applied in a location where it can easily be seen. The label should indicate that the device uses a hydrostatic release, along with its servicing or expiration date.
  - (3) Weak Links. An important part of a float-free survival craft installation is the weak link which secures the survival craft painter to the vessel. Different weak link arrangements are used with different hydrostatic releases. The weak link arrangement must agree with the instructions of the hydrostatic release manufacturer, the survival craft manufacturer, or NVIC 1-83 in the case of life floats and buoyant apparatus.

## SECTION B: DOMESTIC INSPECTION PROGRAMS

## CHAPTER 1: INSPECTION OF VESSELS FOR CERTIFICATION

- h. Ring Lifebuoys, Life Floats, And Buoyant Apparatus. Check the covers of the ring lifebuoys, life floats, and buoyant apparatus to make sure they are intact and that buoyancy material is not exposed. Check cordage to make sure that it is good condition, and not weakened by weathering. Stowage arrangements should allow these devices to be readily cast loose, or to float free, as required by the regulations. Check painters for life floats and buoyant apparatus with the guidance in NVIC 1-83.
- i. Ring Lifebuoy Quick-Release Device. A quick-release device is required for two ring lifebuoys on vessels on international voyages. The lifebuoys must have a floating electric water light and a self-activating smoke signal attached to them.
- (1) Procedure. Operate each quick-release device. A self-activating smoke signal is not required for this test if a dummy device of comparable size and weight is used. A lanyard may be used to keep the ring buoy and its accessories from falling to the surface, or hitting the side of the vessel. Activation of the smoke signal, in particular, should be avoided.
- (2) Acceptance Criteria. The quick-release device must be able to be operated from the bridge. The ring lifebuoy and its attachments must be properly released and drop clear of the side of the vessel. The smoke signal must be mounted properly so that it will ignite when the ring buoy is released.
- j. Floating Electric Water Lights. Check the number and installation of each floating electric water light on board. Activate each one briefly to confirm that the battery is fresh and properly installed.
- k. EPIRBs And SARTs.
- (1) Test each Emergency Position Indicating Radio Beacon (EPIRB) and each Search and Rescue Radar Transponder (SART), except an EPIRB or SART in an inflatable liferaft. Use the test switch and output indicator to determine that the device is operating properly. The "TEST" switch or switch position can be used at any time, since no signal is transmitted. Avoid using the "ON" position to test an EPIRB. Note that some EPIRBs may have a "TEST/ON" position. These EPIRBs go through a test cycle before beginning to transmit an emergency signal. These EPIRBs should be switched back to the "ARMED" or "READY" position as soon as the test cycle is complete.
- (2) Confirm that the operator has registered a 406 MHz satellite EPIRB with the National Oceanographic and Atmospheric Administration (NOAA). If operators need assistance with registration, they can use the following website to register: <http://beaconregistration.noaa.gov/>. Alternatively, registration inquiries can be addressed with NOAA at:

SARSAT Beacon Registration



**SECTION B: DOMESTIC INSPECTION PROGRAMS****CHAPTER 1: INSPECTION OF VESSELS FOR CERTIFICATION**

National Oceanic and Atmospheric Administration  
NSOF, E/SP053  
4231 Suitland Road  
Suitland, MD 20746  
Phone: 301.817.4515  
Toll free: 888.212.7283  
Fax: 301.817.4565

**1. Lifejackets, Immersion Suits, And Work Vests.**

- (1) Examine each lifejacket, immersion suit, and work vest to determine that the proper number are on board, and that each is in serviceable condition, equipped with retroreflective material, and properly marked with the name of the vessel. (See section 18.H.4.e and NVIC 14-92 if "Extended Size" lifejackets are used.) For an initial inspection, lifejackets, immersion suits, and work vests will usually be new and will not require a detailed inspection. However, if older devices are used, they should be inspected as in section P.3.m or section P.3.n. If needed to keep track of devices which have been inspected, the marine inspector may mark or stamp the lifejackets, immersion suits, and work vests to indicate that they have been inspected and passed. (See 18.H.4 and 18.H.5 of NVIC 14-92 for information on stowage and other special considerations.)
- (2) All lifejackets and immersion suits placed on board U.S. flag SOLAS ships after July 1, 2010 must have an approval number in the format 160.155/200 or above, 160.171/200 or above, respectively. See NVIC 03-10.

NOTE: Some regulations may indicate that lifejackets will be stamped "passed" once they have been inspected, however, inspectors may regard this as optional unless an operator insists that the stamps be applied.

- m. Lifejacket Lights. Each lifejacket and immersion suit on a vessel operating on ocean, coastwise, or Great Lakes voyages, must be equipped with an approved light under approval series 160.012 or 160.112. The light must be positioned near the shoulder so it will be above water when a person is wearing the lifejacket or immersion suit in the water. Except for one-use lights, such as chemiluminescent lights (chemical lights) and those with water-activated batteries, turn each light on and off to make sure it operates. The light or the power source must be marked with a date of expiration, unless it is a standard battery such as a 9-volt or D-cell. Operators of vessels operating in near-freezing waters should be aware that battery and light operation degrades in cold temperatures. In particular, chemiluminescent type lights should be avoided on vessels operating in near-freezing waters.

## SECTION B: DOMESTIC INSPECTION PROGRAMS

## CHAPTER 1: INSPECTION OF VESSELS FOR CERTIFICATION

- n. Whistles. Lifejackets and immersion suits on vessels on international voyages must each have a whistle attached to the device with a lanyard. The lanyard must be long enough to allow the whistle to reach the mouth of the wearer. The whistle must be a ball-type or multi-tone whistle of corrosion-resistant construction. The lanyard and whistle must both be in good, operable condition.
- o. Distress Signals. Depending upon its service, the vessel may be required to carry flares or smoke signals in an appropriate stowage location in or near the pilothouse. Flares and smoke signals must be approved, of the appropriate type required by SOLAS or the vessel regulations in 46 CFR Subchapter W and/or corresponding subchapter under which the vessel is certificated, as applicable, and not past their expiration date.
- p. Line Throwing Appliances. Check each line-throwing appliance to make sure that it has the proper stowage arrangements, and that each dated component has not expired. Each line-throwing appliance must also have the equipment on the list provided with the approved appliance. Make sure that an auxiliary line of the correct size and length is provided, and that it is in good condition. If the logbook shows that a required test firing is due, witness a test firing if it can be safely carried out where the inspection takes place.
- q. Pilot Ladders And Embarkation - Debarkation Ladders. Though not strictly "lifesaving equipment," pilot ladder inspections are covered here because of their similarity to embarkation - debarkation ladders. Any new pilot ladder is required to be approved under approval series 163.003. Rope embarkation - debarkation ladders are approved under approval series 160.117, or are approved as equivalent to chain ladders under approval series 160.017. Rope embarkation-debarkation ladders are similar to approved pilot ladders, except that embarkation - debarkation ladders are not required to have spreader steps. Chain ladders are approved under approval series 160.017. All ladders must be a single length of ladder.
- (1) See IMO Assembly Resolution A.1045(27) for information on pilot ladder installation and other pilot transfer arrangements.
  - (2) Any new embarkation-debarkation ladder on a ship certificated for international voyages, must be a rope ladder. These ladders must extend from the deck to the waterline in the lightest seagoing condition at a 15 degrees adverse list. Any other ladder must be either an approved chain ladder or rope ladder. These ladders must extend from the deck to the waterline in the lightest seagoing condition, with no list assumed.
  - (3) The embarkation - debarkation ladder must be secured to the deck adequately, and must be ready to be deployed.

## SECTION B: DOMESTIC INSPECTION PROGRAMS

**CHAPTER 1: INSPECTION OF VESSELS FOR CERTIFICATION**

- (4) Approved pilot ladders and embarkation-debarkation ladders are manufactured under carefully controlled conditions, under the inspection of an independent laboratory. This assures that the ladders will be well constructed and suitable for their intended purpose. Steps are assembled to the ladder at regular intervals in a safe and proper manner. Side ropes are properly straightened and tensioned, so that the steps remain level and safe to use. These ladders, especially pilot ladders, are subject to extremely hard use, and steps will occasionally be damaged. For this reason, replacement steps are also approved. These steps are white or yellow, rather than the orange of the original steps, so that they are readily apparent to anyone inspecting or using the ladder. This conspicuous marking helps draw attention to steps which have not been installed under the same careful conditions as those of the original ladder. Vessels under Coast Guard inspection may not field assemble pilot ladders and embarkation-debarkation ladders. Such ladders will not be considered to be approved, even if assembled from approved replacement steps.
- r. Powered Pilot Hoists. Per IMO Resolution MSC.308(88), pilot hoists may not be used on SOLAS ships effective July 1, 2012. Though not strictly "lifesaving equipment," powered pilot hoist inspections are covered here because of their similarity to other lifesaving equipment inspections. The initial inspection should also include a comparison of the manufacturer's installation instructions with the mounting and power connection provisions provided on the vessel.
- (1) Suspension Cables.
- (a) Procedure. Inspect suspension cables for proper routing. Consult the manufacturer's instructions for specific guidance.
- (b) Acceptance Criteria. Suspension cables must be properly routed through sheaves and blocks. Connections at the ends of the suspension cables, such as clamping or socket arrangements must be properly made. All sheaves must be properly lubricated and turn freely.
- (2) Light Load. Operating the pilot hoist at light load demonstrates that the mass of the ladder or lift platform is sufficient to overcome the frictional resistance of the winch, falls, sheaves, blocks, and associated gear. This test can generally be completed quickly, since no special loading is required.

**SECTION B: DOMESTIC INSPECTION PROGRAMS****CHAPTER 1: INSPECTION OF VESSELS FOR CERTIFICATION**

## (a) Procedure.

- [1] The empty ladder or lift platform should be used for this test.
- [2] Lower the hoist by operating the control lever until the ladder or lift platform reaches the water or its lowest extent of travel. Release the control lever several times while lowering.
- [3] Raise the hoist by operating the control lever until the ladder or lift platform reaches its upper extent of travel. Release the control lever several times while hoisting.
- [4] Lowering and hoisting speed do not need to be measured unless the hoist appears to be operating in an inadequate or unsafe manner.

## (b) Acceptance Criteria.

- [1] There shall be no deformation of or damage to the pilot hoist or its connections to the vessel.
- [2] When the control lever is released, it must automatically return to the off position, and bring the ladder or lift platform to a safe stop. The hoist must begin to move each time the control lever is operated. No additional force is permitted.
- [3] The suspension cables must wind onto the drum in a single level wrap.
- [4] For a multiple suspension cable system, the cables must wind off the drums at the same rate when lowering. The cables must wind onto the drums evenly and at the same rate when hoisting.

## (3) 10% Overload.

## (a) Procedure.

- [1] Load the ladder or lift platform with deadweight so that the total load including the ladder or lift platform equals 1.1 times the working load. The working load will be shown on the nameplate of an approved pilot hoist.
- [2] Lower the hoist by operating the control lever until the ladder or lift platform reaches the water or its lowest extent of travel. Release the control lever several times while lowering.

**SECTION B: DOMESTIC INSPECTION PROGRAMS****CHAPTER 1: INSPECTION OF VESSELS FOR CERTIFICATION**

- [3] Raise the hoist by operating the control lever until the ladder or lift platform reaches its upper extent of travel. Release the control lever several times while hoisting.
- [4] Lowering and hoisting speed do not need to be measured unless the hoist appears to be operating in an inadequate or unsafe manner.
- [5] Disconnect the power source. With one person operating the hand operating device, lower and raise the ladder or lift platform a short distance. If difficulty is encountered, the weight may be reduced to equal the working load, and the test repeated.

**(b) Acceptance Criteria.**

- [1] There shall be no deformation of or damage to the pilot hoist or its connections to the vessel.
- [2] When the control lever is released, it must automatically return to the off position, and bring the ladder or lift platform to a safe stop. The hoist must begin to move each time the control lever is operated. No additional force is permitted.
- [3] The suspension cables must wind onto the drum in a single level wrap.
- [4] For a multiple suspension cable system, the cables must wind off the drums at the same rate when lowering. The cables must wind onto the drums evenly and at the same rate when hoisting.
- [5] For pilot hoists with an emergency stop switch operated by a control wire on the ladder or lift platform, the untended control wire must feed out properly with the ladder or lift platform. The pilot hoist operation must not be affected by the mass of the fully extended control wire.
- [6] The hand operating device must be capable of lowering and raising the working load.

## SECTION B: DOMESTIC INSPECTION PROGRAMS

## CHAPTER 1: INSPECTION OF VESSELS FOR CERTIFICATION

## (4) Emergency Stop Control.

- (a) Procedure. Once the hoist has been demonstrated to be in satisfactory operating condition, put a person on the ladder or lift platform. Lower the hoist, and with the control lever in position to lower the hoist, the person on the ladder or lift platform operates the emergency stop control. Repeat the test of the emergency stop control while hoisting. Test the proper operation of any other control provided on the ladder or lift platform.
  - (b) Acceptance Criteria. The emergency stop control must bring the ladder or lift platform to a safe stop regardless of the position of the on-deck control lever. Each other control on the ladder or lift platform must operate properly and safely.
- s. Abandon-Ship Simulation. Hold an abandon-ship simulation. Determine the time required for all persons on board to be launched into the water in survival craft. This test is not required if the Coast Guard has witnessed a successful test on a sister vessel with the same lifesaving appliance arrangements.

## (1) Procedure.

- (a) Start timing when the signal to abandon ship is given, with all persons at the locations identified in the station bill (muster list).
- (b) No preparation of the survival craft or launching appliance is permitted until the signal is given.
- (c) This simulation must include loading and launching of sufficient survival craft to demonstrate that the acceptance criteria can be met.
- (d) If the survival craft include davit-launched liferafts, one example of each launching appliance type and arrangement on the ship must be tested. If so desired, persons may be used only in the preparing and loading operations, and ballast may be substituted for the lowering and launching part of the test. The time should be recorded for the sequence of preparing, loading, and launching all of the liferafts intended to be launched from the launching station. However, if more than three liferafts are intended to be launched from the launching station, the test may be limited to three liferafts. The total time required to launch all of the liferafts can be extrapolated from this data.

**SECTION B: DOMESTIC INSPECTION PROGRAMS****CHAPTER 1: INSPECTION OF VESSELS FOR CERTIFICATION**

- (e) If the vessel is equipped with marine evacuation systems (MES), the simulation must include full deployment of at least one system, including the launching and inflation of associated liferafts. The time should be recorded for the sequence of preparing, loading, and launching all of the liferafts intended to be launched from the launching station. However, if more than three liferafts are intended to be launched from the launching station, the test may be limited to three liferafts. The total time required to launch all of the liferafts can be extrapolated from this data.
- (f) During the simulation, care must be taken to minimize the hazards associated with the loading and unloading of boats. Casualties have occurred because adequate safety precautions were neglected or because personnel took needless chances.

**(2) Acceptance Criteria.**

- (a) For cargo ships, the abandonment time must be 10 minutes or less.
- (b) For passenger ships, the abandonment time must be 30 minutes or less.
- t. Abandon-Ship Drill And Fire Drill. Once the vessel's initial operating crew is aboard, conduct an abandon-ship drill and a fire drill as described in section P.3.v below.

**3. Subsequent Inspections For Certification**

Each item of lifesaving equipment is inspected to determine that it is in serviceable condition. Each item not in serviceable condition is repaired or replaced. Each item of survival equipment with an expiration date on it is replaced if the expiration date has passed. The following inspections and tests are intended for each inspection for certification other than the initial inspection.

- a. Davit And Winch Launching Systems For Lifeboats. Including Auxiliary Launching Systems For Free-Fall Lifeboats. (See C.2.H.7 of this manual for special considerations concerning lifeboat handling equipment.)

**SECTION B: DOMESTIC INSPECTION PROGRAMS****CHAPTER 1: INSPECTION OF VESSELS FOR CERTIFICATION****(1) Falls.**

- (a) Procedure. Inspect falls for broken strands, damaging corrosion and proper lubrication. When the boat is in the stowed position, the sections of the falls that are bent over the sheaves can be crushed and flattened making the falls more prone to damage in this area; pay particular attention to these sections of the falls prior to and during the full load test. In addition, sheaves are designed to handle wire rope of a particular diameter. Over years of use the groove of the sheave can be widened to the point that the wire rope is not properly supported in its travel and can be damaged due to flattening. Should the wire rope appear separated during the inspection, consider gauging the sheaves with a groove gauge. Since falls can not be internally inspected, one of the maintenance procedures in paragraph (c) is strongly recommended for all vessels, even if not specifically required by the regulations.
  - (b) Acceptance Criteria. Falls must be properly lubricated and free of broken strands and damaging corrosion. Connections at the ends of the falls, such as clamping or socket arrangements must be properly made. All sheaves must be properly lubricated, turn freely, and not show excessive wear.
  - (c) Maintenance - SOLAS Ships and MODUs. Each fall used in a launching appliance on a SOLAS ship or MODU may comply with either 46 CFR 199.190(j) or SOLAS III/20.4. A corrosion-resistant tag is recommended on each fall to record the date the new fall was installed and when it was turned end for end. Make sure the full load test in P.3.a.(3) is conducted after falls are turned or replaced.
- (2) Light Load. Operating the launching system at light load demonstrates that the mass of the boat is sufficient to overcome the frictional resistance of the winch, falls, sheaves, blocks, and associated gear. For boats with a hydrostatic lock on the release mechanism, it verifies that the lock operates at the lowest operational hydrostatic pressure. This test can generally be completed quickly, since no special loading is required for a fully equipped boat. The test is especially important on older installations to test the condition of rollers, bushings, bearings, and other rolling and sliding parts.



**SECTION B: DOMESTIC INSPECTION PROGRAMS****CHAPTER 1: INSPECTION OF VESSELS FOR CERTIFICATION**

## (a) Procedure.

- [1] The boat should approximate its condition "A" weight for this test, with added weight of equipment and fuel on board. Precise loading and load measurement is not necessary, however. In addition, one person may be on board to operate an on-board winch brake control or the release mechanism. If additional personnel are needed to complete the test and to recover the boat, they may board when the boat reaches the water.
- [2] Release the gripes, if necessary. Tricing, frapping, and/or bowsing gear do not need to be used for this test if they are not needed.
- [3] Lower the boat by releasing the winch brake. If the winch brake is arranged for control from within the boat, a person on board the boat should operate the winch brake control.
- [4] Lowering speed does not need to be measured unless the winch and winch brake do not appear to be operating properly. (Refer to section 6.P.2.a on initial inspections for lowering speed requirements.)
- [5] Launch the boat into the water using the normal launching procedure. There are three different operational modes for approved release mechanisms, with the "normal" procedure being different for each.
  - Most 160.133 approval series release mechanisms have a hydrostatic lock which allows the hooks to be released once the boat is in the water; only lifeboats approved under approval series 160.135 and installed after January 1, 2013 will have a release mechanism with a hydrostatic interlock or some other means to ensure the lifeboat is waterborne before the release mechanism can be activated.. With the keel of the boat at or just in the water and tension on the falls, it should be verified that the hydrostatic lock prevents operation of the release mechanism. Then with the boat lowered into the water, the hydrostatic lock should open and permit operation of the release mechanism.
  - An automatic release mechanism is sometimes used on a boat or survival capsule with a single fall launching system. Once set or cocked, these devices release as soon as tension is off the fall. Set these devices for automatic operation for this test. If a person will be on board the boat as it is lowered, that person should set the release mechanism for automatic operation just before the boat reaches the water.

**SECTION B: DOMESTIC INSPECTION PROGRAMS****CHAPTER 1: INSPECTION OF VESSELS FOR CERTIFICATION**

- On-load release mechanisms such as "Rottmer" gear can release the boat whenever the release handle is moved, whether the boat is in the water or not. Persons in command of the boat and operating this mechanism must fully understand the danger of serious injury or death resulting from premature operation. Release the boat from the falls using the on-load release mechanism control as the boat reaches the water. The keel of the boat should be at or in the water, but there should still be tension on the falls when the release mechanism is operated. The safety pin should not be removed until the boat is in position for release.

[6] Recover the boat with the winch. Anyone on board the boat should disembark when it reaches deck level. No one should be on board the boat when the weight of the davit is taken up by the winch, and the davit moves into its stowage position. This is when most fall and fall attachment failures occur.

(b) Acceptance Criteria.

[1] There shall be no deformation of or damage to the launching appliance or its connections to the vessel.

[2] The brake must be a "deadman" type, always applied unless the operator holds the control handle or mechanism in the position to lower the boat. If the operator releases the brake handle/mechanism, the handle/mechanism returns to the "stop" position, thus applying the brake and stopping the boat. No additional force is permitted.

[3] Each winch drum shall be arranged so the fall wire winds onto the drum in a level wrap. There shall be no more than one layer of wire on the drum when the davit is in stowed position, except that if the maximum fleet angle is not more than 4 degrees, two layers of wire are acceptable on a grooved drum. Winches must be demonstrated to wind the falls evenly on and off the drum, regardless of whether the drum is grooved or smooth. The fleet angle shall not exceed 8 degrees in any winch installation.

[4] For a multiple fall system, the falls must wind off the drums at the same rate when lowering. The falls must wind onto the drums evenly and at the same rate when hoisting.

[5] For launching appliances arranged for control from within the boat, there are two basic types of control. One of these types uses a control wire that pays out as the boat lowers. The control wire must properly operate the winch brake throughout the launching sequence. There must be sufficient length of control wire available inside the boat to operate the winch brake

**SECTION B: DOMESTIC INSPECTION PROGRAMS****CHAPTER 1: INSPECTION OF VESSELS FOR CERTIFICATION**

until the boat is released from the falls. The other type is a "pull -and-go" system. An operator in the boat pulls a control lever or handle on the launching appliance which is accessible from a position on board the boat. Once the control is activated, it holds the brake control in the "lower" position, until a crew member on deck returns it to "stop."

- [6] The release mechanism must open all hooks simultaneously and release the boat into the water in the intended manner. The release mechanism must operate freely, without excessive force being required, and be maintained in accordance with manufacturer's instructions. Pay special attention to painting of working parts, cleaning and replacing grease (if used), condition of cables, universal joints, and overall cleanliness. Hooks that can not be operated without excessive force should not be forced.

(3) Full Load.

(a) Procedure.

- [1] The boat must be in its embarkation position. Tricing pendants, if any, must be disconnected. The boat should be held alongside the ship during loading by means of the installed frapping, and/or bowsing gear.
- [2] Load the boat so that its total weight equals the condition "B" weight shown on its data plate. Hold the boat in position for at least ten minutes and check for deformation, especially at davit and winch foundations and other load-bearing members.
- [3] Lower the boat using the normal lowering procedure, using the on-deck winch control position.
- [4] Lowering speed does not need to be measured unless the winch and winch brake do not appear to be operating properly. (Refer to section 6.P.2.a on initial inspections for lowering speed requirements.)
- [5] Alternately release and apply the brake so the boat stops at approximately 2 m (6 ft) intervals. Complete at least three start-stop cycles. The lowering operation should be carefully planned, so that the boat will not have to be raised to complete the start-stop cycles. Most winches will not be capable of raising the loaded boat.
- [6] Stop lowering just as the boat reaches the water. The keel of the boat should be at or in the water, but there should still be tension on the falls. Release the boat from the falls using the on-load release mechanism control. Release mechanisms with a hydrostatic interlock will require use

**SECTION B: DOMESTIC INSPECTION PROGRAMS****CHAPTER 1: INSPECTION OF VESSELS FOR CERTIFICATION**

of the emergency override device to permit on-load release. . For lifeboats installed after January 1, 2013, the interlock override will include special mechanical protection that must be deliberately destroyed, e.g. by breaking a protective glass or translucent cover. The restoration of the release mechanism in these cases should be planned for, and may require a service technician.

[7] Unload the boat, recover it with the winch, and return it to its stowed position. Observe operation of the limit switches as the davit approaches the stowed position. Anyone on board the boat should disembark when the boat reaches deck level. No one should be on board the boat when the weight of the davit is taken up by the winch, and the davit moves into its stowage position. This is when most fall and fall attachment failures occur.

(b) Acceptance Criteria.

[1] There shall be no deformation of or damage to the launching appliance or its connections to the vessel.

[2] The brake must be a "deadman" type, always applied unless the operator holds the control handle or mechanism in the position to lower the boat. If the operator releases the brake handle/mechanism, the handle/mechanism returns to the "stop" position, thus applying the brake and stopping the boat. No additional force is permitted.

[3] The action of releasing the winch brake control must bring the boat to a stop. No additional force on the winch brake control is permitted. The brake action must be smooth and positive.

[4] Each winch drum shall be arranged so the fall wire winds onto the drum in a level wrap.

[5] For a multiple fall system, the falls must wind off the drums at the same rate when lowering. The falls must wind onto the drums evenly and at the same rate when hoisting.

[6] For launching appliances arranged for control from within the boat, the untended control wire must feed out properly with the boat. The winch brake operation must not be affected by the mass of the fully extended control wire.

[7] The release mechanism must open all hooks simultaneously and release the boat into the water.

**SECTION B: DOMESTIC INSPECTION PROGRAMS****CHAPTER 1: INSPECTION OF VESSELS FOR CERTIFICATION**

[8] The limit switches must disconnect the winch power source 0.3 m (12 in) or more before the davit reaches its fully stowed position.

(4) Special Circumstances. Inclement weather or port conditions may force delay or alteration of the light load and full load tests, especially for MODUs on site. Inspectors should not be delayed for extended periods, waiting for weather to clear. Operators should be allowed to use alternate procedures which accomplish the intent of the tests, such as:

(a) Conduct the light load and full load tests without lowering the boats to the water and releasing them.

(b) Arrange a safety sling forward and aft on the boat. With all the slack out of the tricing pendants, release the boat onto the pendants to prove the operation of the releasing gear.

NOTE: This procedure may not be possible or safe with all launching arrangements.

(c) Operate boat engines in the stowed position or in the water without releasing them from the falls. If the engines are operated with the boat out of the water, an external source of cooling water may need to be supplied to enable extended operation.

(d) The operator should complete the tests when conditions permit. The inspector should issue a Vessel/Facility Inspection Requirements, Form CG-835 requiring completion of the tests to the satisfaction of an attending marine inspector, or alternatively requiring submission of log entries attesting to the satisfactory completion of the tests.

b. Free-Fall Lifeboat Launching Systems. Free-fall lifeboat and launching system installation tests are conducted with the vessel on an even keel. The vessel shall not be lighter than its lightest seagoing draft.

(1) Light Load.

(a) Procedure.

[1] The boat should be arranged for launching by a launching crew on board the boat.

[2] The boat should approximate its condition "A" weight for this test, with added weight of equipment and fuel on board. Precise loading and load

**SECTION B: DOMESTIC INSPECTION PROGRAMS****CHAPTER 1: INSPECTION OF VESSELS FOR CERTIFICATION**

measurement is not necessary. In addition, the minimum launching crew should be on board to operate the on-board launching control.

- [3] The launching crew should launch the boat in free-fall by one of the two independent activation systems for the release mechanism which must be operated from inside the lifeboat. The boat should then be retrieved and examined with respect to the acceptance criteria below.

(b) Acceptance Criteria.

- [1] There shall be no deformation of or damage to the launching appliance or its connections to the vessel.
- [2] There shall be no deformation of or damage to any seat or seat mounting in the lifeboat.
- [3] There shall be no cracks or other structural damage to the hull of the lifeboat or any other structurally important part of lifeboat. Cracks in structural members of a free-fall lifeboat indicate that the structure must be replaced.
- [4] There shall be no cracks in non-structural members which could break loose during a free-fall launching.
- [5] The free-fall release mechanism must operate properly and release the boat from the launching appliance.
- [6] The launching system must operate smoothly, must launch the boat into the water at the intended angle, and must not show any evidence of improper operation.
- [7] The lifeboat must not show any evidence of instability or dangerous characteristics during the launching sequence. Water entry angle will normally be between 40 degrees and 70 degrees from the horizontal. The momentum of the boat should move it away from the vessel after it enters the water.
- [8] There shall be no injury to any personnel in the boat attributable to the free-fall performance of the boat.

**SECTION B: DOMESTIC INSPECTION PROGRAMS****CHAPTER 1: INSPECTION OF VESSELS FOR CERTIFICATION**

[9] If the inspector has reason to believe that the boat is not being launched in a safe and proper manner, the inspector may order that the test be repeated with the boat instrumented with acceleration monitoring equipment. The monitoring and analysis should be done by, or under the supervision of, an independent laboratory accepted by the Commandant (G-ENG-4) for this purpose. The test results are compared with the approval test data to determine whether or not the boat is being launched in a safe and proper manner. . See IMO Resolution MSC.81(70), Revised recommendation on testing life-saving appliances”, Part 1/6.17.

(2) Full Load.

(a) Procedure.

[1] Load each seat in the lifeboat with 75 or 82.5 kg (165 lb to 181.5 lbs) of deadweight properly secured in place to simulate the weight of one person. Only freefall lifeboats approved before July 1, 2010, should use 75 kg weights. Add additional weights to seats or equipment lockers, if necessary, to bring the total boat weight to the condition "B" weight.

[2] The launching crew should launch the boat in free-fall by one of the two independent activation systems for the release mechanism which must be operated from inside the lifeboat. The boat should then be retrieved and examined with respect to the acceptance criteria outlined for the light load test above.

- c. Davits and Winches for SOLAS Rescue Boats and Fast Rescue Boats. Test and inspect launching systems for SOLAS rescue boats in the same way as those for lifeboats under section P.3.a. The hoisting speed for a rescue boat launching appliance must be not less than 0.3 m/s (59 ft/min). If observation or rough timing of the hoisting operation indicates that this requirement may not be being met, the test in section P.2.c.(1) may need to be repeated.
- d. Launching Appliances For Davit Launched Liferrafts.

(1) Falls.

- (a) Procedure. Inspect falls for broken strands, damaging corrosion and proper lubrication. In the stowed position, the sections of the falls that are bent over the sheaves can be crushed and flattened making the falls more prone to damage in this area; pay particular attention to these sections of the falls prior to and during the full load test. In addition, sheaves are designed to handle wire rope of a particular diameter. Over years of use the groove of the sheave can be widened to the point that the wire rope is not properly supported in its

**SECTION B: DOMESTIC INSPECTION PROGRAMS****CHAPTER 1: INSPECTION OF VESSELS FOR CERTIFICATION**

travel and can be damaged due to flattening. Should the wire rope appear separated during the inspection, consider gauging the sheaves with a groove gauge. Since falls can not be internally inspected, one of the maintenance procedures in Paragraph (c) is strongly recommended for all vessels, even if not specifically required by the regulations.

- (b) Acceptance Criteria. Falls must be properly lubricated and free of broken strands and damaging corrosion. Connections at the ends of the falls, such as clamping or socket arrangements must be properly made. All sheaves must be properly lubricated, turn freely, and not show excessive wear.
  - (c) Maintenance - SOLAS Ships and MODUs. Each fall used in a launching appliance on a SOLAS ship or MODU may comply with either 46 CFR 199.190(j) or SOLAS III/20.4. A corrosion-resistant tag is recommended on each fall to record the date the new fall was installed and when it was turned end for end. Make sure the full load test in Section P.3.a.(3) is conducted after falls are turned or replaced.
- (2) Light Load. Operating the launching system at light load demonstrates that the mass of the raft is sufficient to overcome the frictional resistance of the winch, falls, sheaves, blocks, and associated gear. The test is especially important on older installations to test the condition of bushings, bearings, and other rolling and sliding parts.

(a) Procedure.

- [1] Prepare a test load which can be suspended from the automatic release mechanism. The test load shall equal the weight of one of the launching station's liferafts and its equipment, plus 75 kg (165 lb) or 82.5 kg, as appropriate, simulating the weight of one person. An inflated davit-launched liferaft carrying a 75 kg or 82.5 kg weight may be used for the test load, but is not required.
- [2] Lower the test weight from the embarkation deck by releasing the winch brake, and "launch" the weight using the normal automatic release procedure. If a non-buoyant test weight is used, the weight is "launched" onto a surface that will support its weight, rather than into the water. If this is not possible, an additional test will need to be devised to test the automatic release mechanism.
- [3] Lowering speed does not need to be measured unless the winch and winch brake do not appear to be operating properly. Refer to Section P.2.d.(1) for a lowering speed test.



## SECTION B: DOMESTIC INSPECTION PROGRAMS

## CHAPTER 1: INSPECTION OF VESSELS FOR CERTIFICATION

[4] Recover the fall with the hand-operated quick-return mechanism.

(b) Acceptance Criteria.

[1] There shall be no deformation of or damage to the launching appliance or its connections to the vessel.

[2] The brake must always be applied unless the operator, or a mechanism activated by the operator, holds the brake control in the "off" position. The test weight must begin to lower each time the brake is released. No additional force is permitted.

[3] Each winch drum shall be arranged so the fall wire winds onto the drum in one or two level wraps.

[4] The automatic release mechanism must open and release the test weight only after the apparatus is set to open automatically and the load of the test weight is off the fall

[5] The operation of the hand-operated quick-return mechanism must be smooth, rapid, and easy enough for one person to recover the fall.

(3) Full load.

(a) Procedure.

[1] Prepare a test load which can be suspended from the automatic release mechanism. The test load shall equal:

$$1.1*(W + M*P) \quad (\text{in kg})$$

$$1.1*(W + M*P) \quad (\text{in lb})$$

where W is the weight of one of the launching station's liferafts and its equipment, M is 75 kg (165 lbs) for all passenger vessels or 82.5 kg (181.5 lbs) for all other vessels built after July 1, 2010, and P is the number of persons the liferaft is approved to accommodate. An inflated davit-launched liferaft carrying additional weight may be used for the test load, but is not required. Alternatively, the test load may be:

$$1.1*SWL$$

where SWL is the least of the three approved working loads for the davit, winch, or automatic release mechanism.

[2] Lower the test weight from the embarkation deck by releasing the winch brake.

**SECTION B: DOMESTIC INSPECTION PROGRAMS****CHAPTER 1: INSPECTION OF VESSELS FOR CERTIFICATION**

- [3] Lowering speed does not need to be measured unless the winch and winch brake do not appear to be operating properly. Refer to section P.2.d.(2) for the lowering speed test during initial inspections.
- [4] Alternately release and apply the brake so the test weight stops at approximately 2 m (6 ft) intervals. Complete at least three start-stop cycles. The lowering operation should be carefully planned, so that the weight will not have to be raised to complete the start-stop cycles, since it may not be possible to raise the weight with the winch.
- [5] "Launch" the weight using the normal automatic release procedure. If a non-buoyant test weight is used, the weight is "launched" onto a surface that will support its weight, rather than into the water. If this is not possible, an additional test will need to be devised to test the automatic release mechanism.
- [6] Recover the fall with the hand-operated quick-return mechanism.

**(b) Acceptance Criteria.**

- [1] There shall be no deformation of or damage to the launching appliance or its connections to the vessel.
- [2] The brake must always be applied unless the operator, or a mechanism activated by the operator, holds the brake control in the "off" position. The test weight must begin to lower each time the brake is released. No additional force is permitted.
- [3] The action of releasing the winch brake control must reapply the brake and bring the test weight to a stop within 1 m (39 in). No additional force on the winch brake control is permitted. The brake action must be smooth and positive.
- [4] Each winch drum shall be arranged so the fall wire winds onto the drum in one or two level wraps.
- [5] The automatic release mechanism must open and release the test weight only after the apparatus is set to open automatically and the load of the test weight is off the fall.
- [6] The operation of the hand-operated quick-return mechanism must be smooth, rapid, and easy enough for one person to recover the fall.

**SECTION B: DOMESTIC INSPECTION PROGRAMS****CHAPTER 1: INSPECTION OF VESSELS FOR CERTIFICATION**

## e. Lifeboats And SOLAS Rescue Boats.

## (1) Operational test.

(a) Motor Lifeboats And SOLAS Rescue Boats. Operate each motor lifeboat and SOLAS rescue boat in the water. Conduct the following tests after engine has reached normal operating temperature.

[1] Operate the propulsion system at full speed both forward and astern.

[2] Operate each boat system, such as any powered bilge pump, or water spray system.

[3] Compare compass readings with several known bearings in different directions.

[4] Operate the emergency steering system in totally enclosed lifeboats.

(b) Hand-Propelled Lifeboats. Operate each hand-propelled lifeboat in the water for period of time sufficient to determine that it operates properly both forward and astern. Compare compass readings with several known bearings in different directions.

(c) Oar-Propelled Lifeboats. Operate each oar-propelled lifeboat in the water with a crew sufficient for each oar and the tiller. Compare compass readings with several known bearings in different directions.

## (d) Acceptance Criteria.

[1] The boat and each of its systems must operate properly without overheating or being damaged.

[2] The boat must not have any evident leakage through the hull or around any through-hull fitting.

[3] If compass errors exceed 10 degrees, the compass should be adjusted using the compensating mechanism to minimize the errors. A compass deviation card should be prepared and mounted on or near the compass.

[4] In totally enclosed, fire-protected lifeboats, the water spray system sprinkler heads must operate properly and provide a uniform flow of water over the surface of the lifeboat. Hatch and glass gaskets, dogging devices, and other closures should prevent entry of water.

**SECTION B: DOMESTIC INSPECTION PROGRAMS****CHAPTER 1: INSPECTION OF VESSELS FOR CERTIFICATION**

(2) Air Supply System. The air supply system in gas-protected and fire-protected totally enclosed lifeboats supplies engine combustion air and breathing air when the lifeboat operates in areas of fire on the water or toxic gas atmospheres. These systems should be maintained comparably to breathing air systems used by commercial divers. See 46 CFR 197, Subpart B, and in particular, § 197.340(i) for breathing air standards. Over time, oxidation of metal compressed gas cylinders can reduce oxygen content of air to unacceptably low levels. The inspector does not need to witness the following inspections and tests, if the operator can provide records indicating appropriate air supply system servicing on an annual basis.

(a) Procedure.

- [1] Determine that the air regulator is operating properly either by discharging one or more of the air supply cylinders through the regulator, or by checking the flow rate on a test apparatus.
- [2] Either have an air sample tested for oxygen content, or empty the cylinders, and refill from an appropriate air supply. If cylinders are emptied, conduct an internal visual examination, if possible.
- [3] Check cylinders for compliance with 46 CFR 147.60, including hydrostatic testing every five years.

(b) Acceptance Criteria.

- [1] The air regulator must operate properly.
- [2] Each air supply cylinder must be fully charged and meet 46 CFR 147.60. (See air supply system placards or lifeboat manufacturer's manual for proper system pressure.)
- [3] The air supply must be suitable for breathing.

(3) Air Tank Buoyancy Units. Test each air tank buoyancy unit for air tightness.

Note: By 1965, lifeboats were no longer produced with air tanks for buoyancy. Many older lifeboats have had their air tanks filled with approved buoyant material, so that they no longer rely on air tanks for buoyancy.

(a) Procedure. Using the test nipple on the tank, apply an air pressure of 2 ft of water (610 mm of water, 0.9 psig, or 6 kPa).

(b) Acceptance Criteria. The tank must hold pressure for at least 10 minutes to be considered airtight.

**SECTION B: DOMESTIC INSPECTION PROGRAMS****CHAPTER 1: INSPECTION OF VESSELS FOR CERTIFICATION**

- (4) **Water Tanks.** Water tanks are normally used for the storage of packaged water and provisions. However, they are also intended to hold collected rain water or desalinated water. Therefore, they must be watertight. This shall be demonstrated by the air tightness test described in the preceding paragraph, or by filling them with water and watching for leaks.
- (5) **Inflated And Rigid/Inflated Rescue Boats.** Make sure that the buoyancy compartments are airtight. Once topped up, buoyancy compartments must remain firm for at least 24 hours. If a pressure check is made to determine air tightness, appropriate temperature and barometric pressure corrections must be made. Repair and maintenance of inflated rescue boats must be in accordance with the manufacturer's instructions. Repairs must be made at a servicing facility with the appropriate equipment and skills to affect repairs, except for emergency repairs carried out on board the vessel. Refer to NVIC 04-07.
- (6) **Battery Chargers** Batteries for engine starting and searchlights must have a means for recharging. Determine that the battery charging systems are functional and in accordance with 46 CFR Subchapter J.
- (7) **Survival Equipment.** Check the condition and quantity of equipment stowed in the lifeboat. (NVIC 2-92 contains guidance). If the equipment is known to have been well-maintained by the crew, this inspection may be conducted on a spot-check basis.
- (8) **Hydraulic Engine Starting Systems.** An hydraulic engine starting system can either be a required system, or an optional system. Check the list of accepted engines on the CGMIX website to determine the required engine starting system, and in some cases the hydraulic start is indicated on the lifeboat's approval certificate.
  - (a) Engines started exclusively by hydraulic systems will have two separate accumulators, either of which should be able to start the engine with a comfortable margin. A hand pump is provided to recharge accumulators in order to provide the required manual starting function. An engine-driven pump may also be provided to recharge accumulators after the engine starts.
  - (b) Optional hydraulic systems may be provided on engines that have qualified hand crank starting systems, batteries, or both. Such systems may have only one accumulator.

**SECTION B: DOMESTIC INSPECTION PROGRAMS****CHAPTER 1: INSPECTION OF VESSELS FOR CERTIFICATION**

- (c) Check the pressure in each accumulator using the installed gauge. Make sure the system will hold pressure for at least four hours without any noticeable pressure drop, and will start the engine. Make sure that the hand pump, if required, can recharge the accumulators.
- f. Inflatable Lifesaving Appliances. Check each inflatable liferaft, inflatable buoyant apparatus, inflatable Marine Evacuation System (MES), and inflatable lifejacket to determine that it has been properly inspected and serviced.
  - (1) Each inflatable liferaft, inflatable buoyant apparatus, and inflatable MES is serviced:
    - (a) At an approved servicing facility in accordance with the servicing procedure under 46 CFR Subpart 160.051, or 46 CFR Subpart 160.151, or an alternative approved servicing procedure for an MES;
    - (b) Every 12 months or not later than the next vessel inspection for certification, provided the total time since the date of the last servicing does not exceed 17 months; and
    - (c) Whenever the container of the raft is damaged, or the straps or seal broken.
  - (2) Each inflatable lifejacket is serviced in accordance with the servicing procedure under 46 CFR Subpart 160.176.
- g. Boats And Davits Not Credited As Lifesaving Equipment. Some vessels by nature of their operation, carry special boats and launching equipment in addition to those required for lifesaving purposes. Survey launches, personnel boats, workboats, and similar craft are not subject to approval as lifesaving equipment, but should be sufficiently seaworthy for the waters in which they will be used. The hull and structural components of such boats should be checked for damage and deterioration. Launching equipment for such craft is often intended only to handle an empty boat, with embarkation and debarkation taking place with the boat in the water. However, if the launching equipment results in personnel being suspended over water on wires, the launching equipment and attachments should be checked by a 10% overload test, similar to that for lifeboat and rescue boat launching appliances. After the test, the boat attachments should be visually checked for cracking and distortion. Appropriate data plates should be installed on both the winch and davit.
- h. Hydrostatic Release Units. Check each hydrostatic release unit used in an item of lifesaving equipment, including those used in certain 406 MHz satellite EPIRBs. (See NVIC 4-86 for guidelines on installation of hydrostatic release units for survival craft.)

**SECTION B: DOMESTIC INSPECTION PROGRAMS****CHAPTER 1: INSPECTION OF VESSELS FOR CERTIFICATION**

- (1) **Conventional Hydrostatic Releases.** Conventional hydrostatic releases must be tested annually at an approved facility. Tests are recorded on an inspection tag attached to the device.
- (2) **Disposable Hydrostatic Releases.** Disposable hydrostatic releases must be marked with their expiration date using the tabs on the label. This must be done when the release is installed. Disposable releases must be replaced when the expiration date passes, normally two years from installation. If multiple dates are indicated, the earliest date is the date of expiration.
- (3) **Hidden Installations.** Some hydrostatic releases, especially those used on certain EPIRBs, can not be readily seen when the equipment is properly installed. If the servicing date or expiration date on an installed hydrostatic release can not be readily seen, a label should be applied in a location where it can easily be seen. The label should indicate that the device uses a hydrostatic release, along with its servicing or expiration date.
- (4) **Weak Links.** An important part of a float-free survival craft installation is the weak link which secures the survival craft painter to the vessel. Different weak link arrangements are used with different hydrostatic releases. The weak link arrangement must agree with the instructions of the hydrostatic release manufacturer, the survival craft manufacturer, or NVIC 1-83 in the case of life floats and buoyant apparatus.
- (5) **Satellite EPIRBs With Unapproved Releases.** The Raytheon/JRC model JQE-2A, Alden SATFIND model 406 M3, and Kannad model 406 F satellite EPIRBs include hydrostatic release mechanisms which were accepted as part of the EPIRBs. They carry no Coast Guard approval information, and must be replaced periodically as indicated in the owners manual and the replacement label on the float-free bracket.
  - i. **Ring Lifebuoys, Life Floats, And Buoyant Apparatus.** Check the covers of the ring lifebuoys, life floats, and buoyant apparatus to make sure they are intact and that buoyancy material is not exposed. Check cordage to make sure that it is good condition, and not weakened by weathering. Stowage arrangements should allow these devices to be readily cast loose, or to float free, as required by the regulations. Check painters for life floats and buoyant apparatus with the guidance in NVIC 1-83.
  - j. **Ring Lifebuoy Quick-Release Device.** A quick-release device is required for two ring lifebuoys on vessels on international voyages. The lifebuoys must have a floating electric water light and a self-activating smoke signal attached to them.

**SECTION B: DOMESTIC INSPECTION PROGRAMS****CHAPTER 1: INSPECTION OF VESSELS FOR CERTIFICATION**

- (1) Procedure. Operate each quick-release device. A self-activating smoke signal is not required for this test if a dummy device of comparable size and weight is used. A lanyard may be used to keep the ring buoy and its accessories from falling to the surface, or hitting the side of the vessel. Activation of the smoke signal, in particular, should be avoided.
  - (2) Acceptance Criteria. The quick-release device must be able to be operated from the bridge. The ring lifebuoy and its attachments must be properly released and dropped clear of the side of the vessel.
- k. Floating Electric Water Lights. Check the number and installation of each floating electric water light on board. Activate each one briefly to confirm that the battery is fresh and properly installed, and that the light is in good operating condition. Shake the light and examine the lens to make sure that no water has leaked or condensed inside. Water lights meeting 46 CFR 161.001 have not been permitted to be installed since December 31, 1971. Those installed before then may continue in service, provided that are in good condition. The original BA-23 military dry-cell batteries for these lights are no longer available. Acceptable replacements, if even still available, are general purpose no. 6 dry-cell batteries.
- l. EPIRBs and SARTs.
- (1) Test each Emergency Position Indicating Radio Beacon (EPIRB) and each Search and Rescue Radar Transponder (SART), except an EPIRB or SART in an inflatable liferaft. Use the test switch and output indicator to determine that the device is operating properly. The "TEST" switch or switch position can be used at any time, since no signal is transmitted. Avoid using the "ON" position to test an EPIRB. Note that some EPIRBs may have a "TEST/ON" position. These EPIRBs go through a test cycle before beginning to transmit an emergency signal. These EPIRBs should be switched back to the "ARMED" or "READY" position as soon as the test cycle is complete.
  - (2) Check the battery expiration date. The battery must be replaced if the expiration date has passed. The operator should be alerted to a battery which will soon expire and will need to be replaced.
- m. Lifejackets And Work Vests. Refer to NVIC 03-10. Examine each lifejacket and work vest to determine that the proper number are on board, and that each is in serviceable condition and properly marked with the name of the vessel. See NVIC 14-92 if "Extended Size" lifejackets are used. Each lifejacket and work vest not in serviceable condition is either repaired, or destroyed and removed from the vessel. If needed to keep track of devices which have been inspected, the marine inspector may mark or stamp the lifejackets and work vests to indicate that they have been inspected and passed.



**SECTION B: DOMESTIC INSPECTION PROGRAMS****CHAPTER 1: INSPECTION OF VESSELS FOR CERTIFICATION**

[NOTE: Some regulations may indicate that lifejackets will be stamped "passed" once they have been inspected, however, inspectors may regard this as optional unless an operator insists that the stamps be applied.]

- (1) Procedure. Check the lifejacket visually to determine its general condition. Check the envelope, tie straps, stitching, and lifting attachments. Give them a mild tug if they show signs of rot or deterioration. Other unsatisfactory conditions are excessive hardness, stiffness, lumpiness, nonresilience, dirtiness, or being oil soaked. A gentle squeeze will detect most of these conditions. In addition, check kapok inserts for water logging and mildew. Excessive compression of inserts is not required, because the natural buoyant properties of the kapok fiber provide the required buoyancy, not air in the sealed bag. Although a sealed vinyl pad covering may provide additional buoyancy, its primary purpose is to protect the kapok fibers from water logging, mildewing, and exposure to contaminants. Therefore, inspectors should not concern themselves with small leaks in kapok inserts, provided the conditions cited above are not evident.
  - (2) Acceptance Criteria. Rot, deterioration, or any other unsatisfactory condition identified in the preceding paragraph, is cause for rejection. A leaking kapok insert is acceptable unless there is evidence of moisture or oil soaking, since oil and mildew will break down the waxy kapok fibers. Likewise, if the general condition of a lifejacket is poor, its buoyancy is questionable. Representative samples should be subjected to a buoyancy test in accordance with NVIC 2-63. A lifejacket or work vest that fails to meet the required test, and is found unfit for service and beyond repair, should be destroyed in inspector's presence and removed from the vessel. Minor repairs and cleaning should be accomplished in accordance with the manufacturer's instructions, 46 CFR 160.006, or NVIC 2-63.
- n. Immersion Suits. Refer to NVIC 03-10. Examine each immersion suit to determine that the proper number are on board, and that each is in serviceable condition and properly marked with the name of the vessel. Immersion suits must have operable waterproof zippers, valves and seams which do not leak, and no unrepaired holes. Maintenance instructions are provided with each approved suit. Each immersion suit not in serviceable condition is either repaired, or destroyed and removed from the vessel. If needed to keep track of devices which have been inspected, the marine inspector may mark or stamp the immersion suits to indicate that they have been inspected and passed.

**SECTION B: DOMESTIC INSPECTION PROGRAMS****CHAPTER 1: INSPECTION OF VESSELS FOR CERTIFICATION**

- (1) Overall Inspection. Each suit should be laid out flat, inspected for proper markings, holes, separated seams, missing parts, and other obvious defects. The exterior surface of the suit should not be abraded to the point where foam flotation material is exposed. Removable gloves must be tethered to the sleeves. The suit should be completely dry inside and out.
- (2) Zippers. Zippers can corrode if not properly maintained. The manufacturer's recommended zipper lubricant should be used. Paraffin should be avoided, especially in cold climates. The teeth that actually secure the waterproof zipper are the small teeth on the "inside" of the zipper. A little corrosion on these teeth can block the slider, or damage the teeth so the zipper does not operate. If a closed zipper can be separated when probed with a (dull) table knife, the zipper needs to be replaced.
- (3) Seams. Immersion suit seams are stress points and are often the source of leaks. Suits should be leak checked periodically, and leaking seams repaired in accordance with the manufacturer's recommended repair procedure. Leak checking is most effectively accomplished by inflating the suit using an appropriate adaptor in the head of the suit. If the suit has foot valves, these need to be held shut for this test. If the suit does not retain air, a detergent solution is used to find the source of leakage. This testing does not need to be conducted at each subsequent inspection for certification, especially if the suits appear in good condition, or if records indicate that the suits have been recently leak checked. If the suits are suspect, the inspector should direct that a leak check be conducted on a selected sample of the suits on board, to determine if there is a problem.
- (4) Inflatable Collar. If a suit has an inflatable collar, it must be securely attached to the suit: It should be inflated and allowed to stand overnight. If the collar does not stay firmly inflated overnight, it should be repaired or replaced. Inflation tubes should be complete, securely attached, and not have kinks which would prevent the wearer from inflating the collar.
- (5) Foot Valves. Some suits have one-way foot valves intended to allow excess air and water to escape from the suit. Leaking foot valves are a common source of problems. These valves should be observed to be in their normal closed condition during the inspection. They should be free of debris and distortion that would adversely affect their performance.
- (6) Stowage. Each suit should be kept in a stowage bag of the type provided by the manufacturer. However, keeping the suit on an appropriate hangar in a protected, but readily accessible location is an acceptable alternative. Stowage bags should be inspected to ensure they are in satisfactory condition for the purpose of containing and protecting suits. The exterior of each bag should be marked with the size and the words "immersion suit" or "exposure suit." Suits should not be stacked more than a few high, or be kept on the bottom of a stack of any other

## SECTION B: DOMESTIC INSPECTION PROGRAMS

## CHAPTER 1: INSPECTION OF VESSELS FOR CERTIFICATION

equipment. Excessive stacking can compress suits at the bottom of the pile, eventually damaging the buoyant insulating foam.

- o. Retroreflective Material. Most lifesaving equipment on inspected vessels is now required to be equipped with retroreflective material. This is normally applied by the manufacturer, but may have to be applied by the operator. See NVIC 1-87 and IMO Assembly Resolution A.658(16) for more information on placement of retroreflective material. Retroreflective material that is delaminated, torn, cracked, or discolored must be replaced. Questionable material may be checked for optical performance by examining it with a flashlight. With the flashlight held as close as possible to the observer's eye and pointed at the retroreflective material, the reflective performance of good material will be obvious. Replacement material should generally be positioned in the same place as the old material. Only Coast Guard approved retroreflective material (approval series 164.018) may be used. This material is tested for flexibility, adhesion, and optical performance under cold, wet, and oily conditions. The application directions supplied with the retroreflective material should be carefully followed.
- p. Lifejacket Lights. Except for one-use lights, such as chemiluminescent lights (chemical lights) and those with water-activated batteries, turn each light on and off to make sure it operates. The light or the power source must be marked with a date of expiration, unless it is a standard battery such as a 9-volt or D-cell. Unmarked batteries must be replaced annually and must be of the type designated by the light manufacturer. Other batteries or lights must be replaced by their expiration date. Operators of vessels operating in near-freezing waters should be aware that battery and light operation degrades in cold temperatures. In particular, chemiluminescent type lights should be avoided on vessels operating in near-freezing waters.
- q. Whistles. Lifejackets and immersion suits on vessels on international voyages must each have a whistle attached to the device with a lanyard. The lanyard must be long enough to allow the whistle to reach the mouth of the wearer. The whistle must be a ball-type or multi-tone whistle of corrosion-resistant construction. The lanyard and whistle must both be in good, operable condition.
- r. Distress Signals. Depending upon its service, the vessel may be required to carry flares or smoke signals in an appropriate stowage location in or near the pilothouse. Flares and smoke signals must be approved, of the appropriate type required by the vessel regulations in 46 CFR, and not past their expiration date.
- s. Line Throwing Appliances. Check each line-throwing appliance to make sure that it has the proper stowage arrangements, and that each dated component has not expired. Each line-throwing appliance must also have the equipment on the list provided with the approved appliance. Make sure that an auxiliary line of the correct size and length is provided, and that it is in good condition. If the logbook shows that a required test

**SECTION B: DOMESTIC INSPECTION PROGRAMS****CHAPTER 1: INSPECTION OF VESSELS FOR CERTIFICATION**

firing is due, witness a test firing - if it can be safely carried out where the inspection takes place.

- t. Pilot Ladders And Embarkation-Debarkation Ladders. Though not strictly "lifesaving equipment," pilot ladder inspections are covered here because of their similarity to embarkation-debarkation ladders. Any new pilot ladder on or after 23 July 1984 is required to be approved under approval series 163.003. Rope embarkation-debarkation ladders are approved under approval series 160.117, or are approved as equivalent to chain ladders under approval series 160.017. Rope embarkation-debarkation ladders are similar to approved pilot ladders, except that embarkation-debarkation ladders are not required to have spreader steps. Chain ladders are approved under approval series 160.017. All ladders must be a single length of ladder.
- (1) See IMO Assembly Resolution A.1045(27) for information on pilot ladder installation and other pilot transfer arrangements.
  - (2) Any embarkation-debarkation ladder installed on or after 1 July 1986 on a ship certificated for international voyages, must be a rope ladder. These ladders must extend from the deck to the waterline in the lightest seagoing condition at a 15 degrees adverse list. Any other ladder must be either an approved chain ladder or rope ladder. These ladders must extend from the deck to the waterline in the lightest seagoing condition, with no list assumed.
  - (3) The embarkation-debarkation ladder must be secured to the deck adequately, and must be ready to be deployed.
  - (4) Pilot ladders and embarkation-debarkation ladders must have no cracked or broken steps. Each step must be securely attached to the side members. A vessel may use up to two unapproved temporary replacement steps to replace broken or cracked steps. However, temporary steps will not be accepted at inspections for certification. Broken steps must be replaced by permanent approved replacement steps.
  - (5) Chains and other metal ladder parts must be free of damaging corrosion. Ropes must not be weathered, worn, or greasy. SOLAS 74/83 rope ladders have a safety core of a color which contrasts with the outer cover. If the outer cover is worn through to the core in any place, the ladder must be replaced, or the ladder roped under original manufacturing conditions. Failure to follow the proper ladder assembly procedure will result in steps which are unevenly spaced and not level.
  - (6) Approved pilot ladders and embarkation - debarkation ladders are manufactured under carefully controlled conditions, under the inspection of an independent laboratory. This assures that the ladders will be well constructed and suitable for

**SECTION B: DOMESTIC INSPECTION PROGRAMS****CHAPTER 1: INSPECTION OF VESSELS FOR CERTIFICATION**

their intended purpose. Steps are assembled to the ladder at regular intervals in a safe and proper manner. Side ropes are properly straightened and tensioned, so that the steps remain level and safe to use. These ladders, especially pilot ladders, are subject to extremely hard use, and steps will occasionally be damaged. For this reason, replacement steps are also approved. These steps are white or yellow, rather than the orange of the original steps, so that they are readily apparent to anyone inspecting or using the ladder. This conspicuous marking helps draw attention to steps which have not been installed under the same careful conditions as those of the original ladder. Vessels under Coast Guard inspection may not field assemble pilot ladders and embarkation - debarkation ladders. Such ladders will not be considered to be approved, even if assembled from approved replacement steps. The same thing applies to field "reroping" of ladders - that is using original orange steps to assemble a ladder with new ropes. Ladders assembled in this fashion can not be assembled with the same care as in the manufacturer's facility. There is no objection to the manufacturer using old steps in good condition to rope a ladder under original manufacturing conditions, however.

- u. Powered Pilot Hoists. Per IMO Resolution MSC.308(88), pilot hoists may not be used on SOLAS ships after July 1, 2012.
  - v. Abandon-Ship Drill And Fire Drill. Hold an abandon-ship drill and a separate fire drill. When drills can not be held due to adverse weather conditions or other uncontrollable factors, a Form CG-835 may be issued, granting the vessel a reasonable period of time in which to conduct drills to another inspector's satisfaction. However, these drills are one of the few opportunities Coast Guard inspectors have to interact with the entire crew and to let them know of our concern for their safety. Human error is often identified as being responsible for mishaps. Deferring these drills to a later date is strongly discouraged, particularly if there has been a crew change out. There is rarely a need to defer a fire drill; lifeboat drills can be abbreviated if the weather is rough (i.e., lower the boat to the water but do not release or exercise it).
- (1) Conduct Of Drills.
- (a) Drills shall be carried out in as realistic a manner as possible. The inspector specifies the nature of the emergency to be simulated, including incapacitated officers, crew members, or injured passengers, if appropriate.
  - (b) There shall be no forewarning of the crew to the extent that fire hoses are led out, pumps started, or lifejackets donned prior to the sounding of the general alarm.

**SECTION B: DOMESTIC INSPECTION PROGRAMS****CHAPTER 1: INSPECTION OF VESSELS FOR CERTIFICATION**

- (c) Spot check crew members to make sure they know their stations and are familiar with their duties as contained in the station bill (muster list). The inspector does not direct or instruct personnel at any time during drills; the inspector's duty is only to observe them and note deficiencies.
  - (d) On-load release mechanisms such as "Rottmer" gear can release the boat whenever the release handle is moved, whether the boat is in the water or not. Persons in command of the boat and operating this mechanism must fully understand the danger of serious injury or death resulting from premature operation.
- (2) Fire Drills. Crew members shall demonstrate that they are familiar with fire extinguishers, fixed CO and foam systems, sprinkling systems, hoses and nozzles, steam smothering systems, and all other emergency equipment. Persons in charge shall instruct crew members in the use of the equipment as necessary.
- (3) Abandon-Ship Drills. During abandon-ship drills, care must be taken to minimize the hazards associated with the loading and unloading of the boats. Casualties have occurred because adequate safety precautions were neglected or because personnel took needless chances.
- (a) When possible, all lifeboats shall be lowered to the water.
  - (b) Crews of vessels equipped with oar-propelled lifeboats shall be exercised at rowing.
  - (c) Whenever a lifeboat is being raised, all persons in the boat should be required to disembark before the davit starts to move from its outboard position.
- (4) Acceptance Criteria.
- (a) Crew members must know their stations and be familiar with their duties as contained in the station bill (muster list).
  - (b) The officers and crew must demonstrate that the station bill and their emergency procedures can provide for substitution of key personnel, and different emergencies which may require different actions.
- (5) Unsatisfactory Results. When a drill is considered unsatisfactory, the inspector shall report the results to the OCMI. The drill should be repeated at reasonable intervals until satisfactory results are obtained. The OCMI shall consider unsatisfactory drills as justification for withdrawing or withholding the COI.

**SECTION B: DOMESTIC INSPECTION PROGRAMS****CHAPTER 2: VESSEL REINSPECTIONS, ANNUAL INSPECTIONS, AND PERIODIC INSPECTIONS****A. INTRODUCTION**

Vessel reinspections, annual inspections, and periodic inspections occur between those inspections required by vessel inspection laws. These focus more on the vessel's equipment and operating practices, while inspections required by vessel inspection laws focus on basic hull and machinery conditions. The scope of reinspections, annual inspections, and periodic inspections varies according to the vessel's condition, its record of maintenance, and, at times, the marine inspector's time constraints. Such inspections should verify that all parts of the vessel and its equipment are being maintained in a safe condition. They should not be perfunctory; the vessel's operator should not be able to predict their scope.

---

**1. Scope of Reinspections, Annual Inspections, Periodic Inspections**

During reinspections, annual inspections, and periodic inspections, inspectors must give special attention to lifesaving and firefighting equipment and watertight closures. The inspector should vary the degree of attention they give to individual items as circumstances require. During each reinspection, annual inspection, and periodic inspection, the inspector should inspect accessible parts of the hull and machinery that are prone to neglect and rapid deterioration. The inspector has great latitude in the scope of these inspections, which is based on his or her evaluation of the vessel's overall condition. At a minimum, the guidelines for International Convention for the Safety of Life at Sea (SOLAS) annual inspections must be used for all vessel reinspections, annual inspections, and periodic inspections (see E of this Chapter).

---

**2. Inspector's Obligations**

The inspector must be reasonably satisfied as to the condition of the vessel and its equipment, and must ascertain that the vessel's degree of compliance with statutes, regulations, and the terms of its Certificate of Inspection (COI) warrant continued possession of the COI. As conditions warrant, the inspector may conduct an inspection similar in scope to that of an inspection for certification. In any case, the scope of inspection must be consistent with the requirements found in B2 of this Chapter.

---

## USCG Marine Safety Manual, Vol. II: Materiel Inspection

## SECTION B: DOMESTIC INSPECTION PROGRAMS

**CHAPTER 2: VESSEL REINSPECTIONS, ANNUAL INSPECTIONS, AND PERIODIC INSPECTIONS****3. Vessel Information Sources**

The inspector must use all available evidence when appraising the condition of a vessel and its equipment. This includes the latest inspection findings, records of previous Coast Guard inspections, the opinions or records of other interested surveyors or inspectors, information furnished by the officers and crew, facts concerning the vessel's classification, and previous certification.

**NOTE:** See 46 U.S.C. 3315 concerning the disclosure of sources of information.

The inspector may seek the advice of experts in a particular field, such as boilermakers, shipfitters, and welders, or the opinion of more experienced inspectors or technical personnel assigned to his or her unit. Based on this evidence and his or her own inspection, the inspector must reach an independent conclusion as to vessel and equipment conditions and act accordingly. The Officer in Charge, Marine Inspection (OCMI) must be consulted when there is doubt in the inspector's mind as to a proper course of action.

**4. Commandant's Reinspection Policy**

The Commandant's policy regarding reinspections, annual inspections, and periodic inspections does not restrict an OCMI from requiring reinspection at any time when the OCMI believes that a vessel's degree of compliance no longer warrants continued possession of a COI. However, the OCMI should not require or encourage arbitrary and unnecessary reinspection.

Minor defects or imperfections that do not in themselves hazard the vessel must not be construed as rendering the vessel unfit for continued operation. Vessel owners must be granted reasonable time to correct deficiencies.

**B. REFERENCES****1. Statutes**

Under 46 U.S.C. 3308, all vessels subject to inspections at frequencies specified by 46 U.S.C. 3307 must be examined at proper times to ensure compliance with statutory and regulatory requirements. Under 46 U.S.C. 3714, tank vessels that carry liquid bulk dangerous cargoes must be examined at least once annually. 43 U.S.C. 1348 requires annual inspection of mobile offshore drilling units (MODUs) operating on the U.S. Outer Continental Shelf (OCS).



## USCG Marine Safety Manual, Vol. II: Materiel Inspection

## SECTION B: DOMESTIC INSPECTION PROGRAMS

**CHAPTER 2: VESSEL REINSPECTIONS, ANNUAL INSPECTIONS, AND PERIODIC INSPECTIONS****2. Regulations**

46 CFR 2.01-10(b) provides that the Coast Guard, on its own initiative, may examine, inspect, or reinspect vessels subject to certification at any time. The following regulations require reinspections, annual inspections, and periodic inspections of certificated vessels at stated intervals and establish the scope of such inspections.

<b>VESSEL TYPE</b>	<b>CFR CITATION</b>
Tank Vessels	46 CFR 31.10-17
Passenger Vessels	46 CFR 71.30
Cargo and Miscellaneous Vessels	46 CFR 91.27
Small Passenger Vessels	46 CFR 176.500 (Sub T) 46 CFR 115.500 (Sub K)
Oceanographic Research Vessels	46 CFR 189.27

**3. SOLAS Survey Requirements**

Regulation 6(b), Chapter 1 of the 1978 Safety of Life at Sea (SOLAS) Protocol requires annual surveys of all cargo and tank vessels issued Cargo Ship Safety Construction Certificates (SAFCON) and Cargo Ship Safety Equipment Certificates (SEC). International Maritime Organization (IMO) Resolution A.413(XI), as amended by Resolution A.465(XII), provides an excellent, internationally accepted standard for conducting surveys.

**C. REINSPECTIONS OF PASSENGER VESSELS****1. Large Passenger Vessels (46 CFR Subchapters K and H)**

Reinspections of passenger vessels holding 1-year COIs (certificated under 46 CFR, Subchapter H or K) must be conducted at the discretion of the OCMI. For such vessels, an examination of safety and operating equipment as well as all accessible parts of the hull and machinery that are most prone to neglect or damage must be carried out to the satisfaction of the inspector. Conditions that in themselves do not hazard the vessel, but indicate generally poor condition, should alert the inspector to broaden the scope of the reinspection (see 46 CFR 71.30 for Subchapter H or 46 CFR 115.500 for Subchapter K).

**SECTION B: DOMESTIC INSPECTION PROGRAMS****CHAPTER 2: VESSEL REINSPECTIONS, ANNUAL INSPECTIONS, AND PERIODIC INSPECTIONS****2. Small Passenger Vessels ("T-Boats")**

The scope of annual inspections of small passenger vessels, which hold 5-year COIs under 46 CFR Subchapter T, is described in 46 CFR 176.500 (b). The OCMI must cooperate with vessel owners and operators when scheduling inspections in order to interfere as little as possible with the normal vessel operations. For the inspection of a T-boat with a COI issued in another zone, the OCMI should obtain the vessel's previous inspection records from the certificating OCMI. In such cases, the next OCMI inspecting the vessel should resolve any questions concerning the vessel's structure or equipment with the certificating OCMI before issuing major requirements as a result of the inspection.

**NOTE:** Steam powered T-boats require special consideration for the inspection of their boilers.

---

**D. ANNUAL INSPECTIONS, PERIODIC INSPECTIONS, AND REINSPECTIONS OF TANK, CARGO, AND MISCELLANEOUS VESSELS**

---

**1. Introduction**

Each tank, cargo, miscellaneous vessel and MODU holding a 5-year COI is subject to annual and periodic inspections as outlined in the applicable 46 CFR subchapter. If a vessel has SOLAS certificates, the annual and periodic inspections meet the SOLAS mandatory annual survey requirements (See MSM Volume II, Materiel Inspection, COMDTINST M16000.7A (series), Section E). Annual and periodic inspections, must, if possible, be carried out between the 9<sup>th</sup> and 15<sup>th</sup> months following the date of issuance of the COI. In addition to this requirement, an annual or periodic inspection should normally coincide with a drydock examination, unless the owner or master requests a deferment.

**2. Timing**

If a vessel's drydock examination occurs outside the window for an annual or periodic inspection, it will need to have a reinspection. This reinspection's scope should vary depending on the time of the vessel's drydocking relative to the date of the previous or next required inspection. For example, a drydocking that occurs shortly after the inspection for certification should have a reinspection that is very limited in scope. Likewise, a reinspection associated with a drydock that occurs shortly before the expiration of a COI should not duplicate the scope of an inspection for certification, but must be sufficient to ensure safe operation of the vessel.

---

**3. Standards for Annual Inspections, Periodic Inspections, and Reinspections**

**SECTION B: DOMESTIC INSPECTION PROGRAMS****CHAPTER 2: VESSEL REINSPECTIONS, ANNUAL INSPECTIONS, AND PERIODIC INSPECTIONS**

These types of inspections are normally less detailed than the inspection for certification. However, they must still be sufficient to verify that the vessel's condition and operation remain satisfactory and that the vessel can continue to operate safely. The inspector must inspect all accessible parts of the hull and machinery, especially those prone to rapid deterioration and neglect. The inspector must give particular attention to lifesaving, firefighting and watertight equipment. Equipment and devices for vessel control must be tested and emergency drills held, if practicable.

Annual and periodic inspections required by 46 CFR 91.27, as described in this part of the MSM, are mandatory. The continued validity of a vessel's COI depends on the satisfaction of this requirement. These inspections may be conducted within the United States or at a foreign port or place. When an owner/operator chooses to have the inspection conducted at a foreign port or place, they will be responsible for reimbursement for the inspector's travel and subsistence.

At the 1-year anniversary of the vessel's COI, the certifying OCMI should issue a letter to the vessel's operator advising that the required inspection is due. Annual and periodic inspections are due no later than the 15-month anniversary date of the COI's issuance. If, after the 15-month anniversary date of the COI, the inspection has not commenced, been completed, or been deferred, the owner and operator will be advised that the vessel's COI is suspended under the authority of 46 U.S.C. 3313(b)(4) until the required inspection is completed. This notification will be made by letter and telephone/FAX and an appropriate entry will be made in MISLE and the local vessel file.

Requests for deferment of inspection beyond the 15<sup>th</sup> month of the COI anniversary date will be closely evaluated by the cognizant OCMI. Examples of situations in which deferments may be granted include rescheduling to make concurrent inspections ("harmonize" inspections) or the unavailability of inspection personnel.

---

**4. RIN Alternative Provisions for Offshore Supply Vessels**

The RIN Alternative Provisions for Offshore Supply Vessels (OSVs) is an alternative inspection program for OSVs under 400 GT operating overseas. This program allows owners/operators or designated third parties to perform an alternative mid-period examination and submit a report to the cognizant OCMI in lieu of having a marine inspector travel overseas to perform a mid-period reinspection. Liftboats are excluded from the program. The program does not delegate inspection duties to any private party.

**SECTION B: DOMESTIC INSPECTION PROGRAMS****CHAPTER 2: VESSEL REINSPECTIONS, ANNUAL INSPECTIONS, AND PERIODIC INSPECTIONS**

- a. When aboard any OSV under 400 GT, except liftboats, marine inspectors should be aware that an OCMI may have to determine, at a later date, whether the vessel should be allowed to participate in the program. If the vessel previously participated in the alternative program, the inspector should pay close attention to deficiencies which may have existed before the mid-period, but were not corrected.
- b. When deficiencies are reported in the alternative examination report which is accepted in lieu of a Coast Guard mid-period reinspection, they should be entered into MSIS and tracked in the normal manner. The OCMI must establish compliance deadlines for outstanding deficiency items or approve those proposed by the owner/operator. The OCMI may determine the report is so deficient that a Coast Guard mid-period reinspection is required. The owner/operator must be informed, and a time limit for scheduling the mid-period reinspection specified.

---

**E. ADMINISTRATION OF ANNUAL INSPECTIONS, PERIODIC INSPECTIONS, AND REINSPECTIONS**

---

**1. Actions by the OCMI**

The OCMI must control inspections of all vessels certificated in their zone, insofar as practicable, and ensure that other vessels in their zone are inspected, as appropriate.

**NOTE:** This does not mean that a vessel certificated in one zone must be inspected there.

The continued validity of a vessel's COI is contingent upon the satisfaction of the annual, periodic and reinspection requirements. For those vessels that are issued a 5-year COI, the following procedures are applicable to ensure compliance with the requirements:

- a. Notification. Prior to each anniversary year of the COI, the certificating OCMI should issue a letter to the vessel's owner or operator advising that the required inspection is due. This notification is performed as a matter of courtesy and does not affect the responsibility of the owner/operator to comply with the inspection requirements.
- b. Deferments. In the event that an owner/operator requests deferment of the required inspection past the 15th month of the COI's anniversary date, the OCMI will evaluate the request and, if found justified, grant a deferment.
  - (1) Requests for deferments past the 15th month should be closely evaluated. Failure of an owner/operator to plan and schedule an inspection is not sufficient justification for a deferment.

**SECTION B: DOMESTIC INSPECTION PROGRAMS****CHAPTER 2: VESSEL REINSPECTIONS, ANNUAL INSPECTIONS, AND PERIODIC INSPECTIONS**

- (2) If a deferment is granted, the owner/operator should be issued a requirement (either a Vessel/Facility Inspection Requirements, Form CG-835 or letter) to complete the inspection within a specified length of time which must not exceed the 17th month of the COI's anniversary date.

**NOTE:** These actions are applicable to small passenger vessels.

---

**2. Actions by Owners, Operators, and Masters**

- a. The regulations require annual inspections, periodic inspections, and reinspections of certain vessels each year between the 9<sup>th</sup> and 15<sup>th</sup> month after the COI's anniversary date (the anniversary of the date the COI was issued). (See Paragraph B2 above for citations.)
  - (1) It is the responsibility of the owner and operator to arrange for inspection before the end of the 15<sup>th</sup> month or, when that is not possible, to obtain a deferment from the OCMI. Failure to do so subjects the owner, operator, and others to civil penalty liability.
  - (2) The OCMI must cooperate, insofar as practicable, with owners and operators to schedule inspections to avoid conflict with vessel operating schedules. Deferment requests that have merit should be granted when the required inspection can be accomplished at a later time provided it is conducted as noted above before expiration of the COI.
  - (3) Written applications for annual inspections, periodic inspections, and reinspections are not required.
- b. Responsibilities. Vessel representatives of tank, cargo, miscellaneous, and inspected oceanographic research vessels must be advised of items that the regulations require to be inspected, serviced, or replaced at certain intervals.
  - (1) The vessel owner is responsible to ensure that required inspections and tests are held when due (e.g., hydrostatic tests of boilers and inspections of boiler mountings). If they are not held when due, the owner may be subject to a marine violation, civil penalties, and possible revocation of the vessel's COI.
  - (2) The benefits of conducting these tests and inspections at regular inspection intervals should be obvious to owners. Unexpected changes to a vessel's schedule may compel an owner to depart from this desired practice. In doing so, an owner

## USCG Marine Safety Manual, Vol. II: Materiel Inspection

**SECTION B: DOMESTIC INSPECTION PROGRAMS****CHAPTER 2: VESSEL REINSPECTIONS, ANNUAL INSPECTIONS, AND PERIODIC INSPECTIONS**

does not become immediately liable for a penalty, but incurs the inconvenience of having to be inspected at a later time.

- (3) The vessel's representative must be reminded of the responsibility to replace or service vessel equipment at or prior to the due date (see 46 CFR 31.10-18, 97.15-60, and 196.15-60).

---

**F. RECORDS OF ANNUAL INSPECTIONS, PERIODIC INSPECTIONS, AND REINSPECTIONS**

---

**1. COI**

Annual inspections, periodic inspections, and reinspections must be recorded on the COI in the space provided.

If the vessel has SOLAS certificates, the mandatory annual survey endorsement on the reverse of the SEC and the SAFCON (if issued) must also be completed by the OCMI or an authorized representative.

---

**2. Vessel Inspection Record, Form CG-2832**

An entry noting the type of inspection completed must be made on Vessel Inspection Record, Form CG-2832, which is kept in the vessel's pilothouse.

---

**3. Inspection Book Series, Form CG-840**

The inspector must record all reinspections in the appropriate Inspection Book Series, Form CG-840. When a reinspection is of lesser scope (e.g., correcting specific discrepancies), the inspector may use a local examination form developed by the OCMI to note the circumstances of the reinspection for local office records. When reinspection of a tank, cargo, miscellaneous, or oceanographic research vessel is performed in conjunction with a drydocking, but is not of the scope of a mid-period reinspection, it may be recorded in booklet Inspection Book, Form CG-840, at the OCMI's discretion. The entry "Limited reinspection indicates satisfactory condition" will serve the purpose in such cases.

---

USCG Marine Safety Manual, Vol. II: Materiel Inspection

**SECTION B: DOMESTIC INSPECTION PROGRAMS****CHAPTER 2: VESSEL REINSPECTIONS, ANNUAL INSPECTIONS, AND PERIODIC INSPECTIONS****4. Marine Information for Safety and Law Enforcement (MISLE) Entries**

Units must make appropriate entries for all annual inspections, periodic inspections, and reinspections.

---

**G. CRITICAL AREAS INSPECTION PLAN (CAIP) SURVEYS**

General Surveys required as a part of a vessel's CAIP must be conducted as outlined in NVIC 15-91, NVIC 15-91, Change 1 and MSM II, Materiel Inspection, COMDTINST M16000.7A (series), Chapters A5 and B4.

---

## USCG Marine Safety Manual, Vol. II: Materiel Inspection

## SECTION B: DOMESTIC INSPECTION PROGRAMS

## CHAPTER 3: HULL EXAMINATIONS

**A. HULL EXAMINATIONS**

---

**1. Introduction**

The final rule implementing the revised drydock and tailshaft regulations established three separate, required examinations of a vessel's hull; Drydock Examination (DE), Internal Structural Examination (ISE), and Cargo Tank Internal Examination (CTIE). (*Federal Register*, Vol. 53, August 24, 1988.)

These exams replace the all-inclusive examination previously referred to as a "drydock" exam. The definition, scope, and interval of each exam are specified in the applicable sections of 46 CFR.

**NOTE:** The revised drydock and tailshaft regulations do not apply to 46 CFR Subchapter T and Subchapter IA vessels.

**NOTE:** Credit for the exam must be given on the date that all the requirements of the exam are met, not on the date the exam began.

---

**2. Hull Exam Intervals**

For the majority of oceangoing vessels, the intervals for all DE, ISE, and CTIE examinations are the same, i.e., twice within any 5-year period with no more than 3 years between any two exams. For most other vessels, all three exams will coincide several times during the life of the vessel, affording Coast Guard marine inspectors the opportunity to conduct a complete assessment of the vessel's hull structure.

The three distinct examinations also allow the Coast Guard to account for the additional levels of safety inherent in specific vessel designs, such as a double hull tank barge with internally framed cargo tanks in fresh water service. These vessels have a 10-year DE interval and 5-year CTIE and ISE intervals.

---



**SECTION B: DOMESTIC INSPECTION PROGRAMS****CHAPTER 3: HULL EXAMINATIONS****3. Concurrent Hull Examinations**

Hull examination intervals, particularly those that fall between year 2 and year 3 of a 5-year interval, should result in these examinations coinciding with an inspection for certification, annual inspection, periodic inspection, reinspection, or, in the case of tailshafts, a DE. This is ideal but not mandatory.

If a vessel owner elects to conduct any of the hull examinations early, then he or she should be advised that any other hull examination due at the same time should also be conducted early.

The owner or master may, if operational commitments do not permit all hull examinations being completed together, decide to schedule an exam at a later date, provided that the exam is accomplished within the maximum time interval allowed by the regulations.

---

**4. Extension of Hull Exams**

- a. Extensions of hull examinations. Hull examinations must be conducted in accordance with the applicable regulations, except in instances where extensions are authorized.
  - (1) A vessel owner or operator must submit any request for an extension of a hull exam to the cognizant OCMI.
  - (2) To avoid unwarranted extension requests, OCMI should ensure that owners and operators are aware that Commandant (CG-CVC) only grants DE extensions in the most unusual circumstances. Examples of unusual circumstances are the sudden unavailability of drydock space (e.g., due to high river stage, weather damage to facilities, or of the scheduled drydock facility going out of business), the employment of the vessel where it cannot be replaced without risk, or circumstances clearly beyond the owner's control. Financial hardship alone is not a valid reason for granting a drydock extension.
- b. Action following receipt of an extension request. Upon receipt of a request for extension of any hull examination, the OCMI should ascertain the condition of the vessel in question. A visit to the vessel is necessary in all but the most unusual circumstances.
  - (1) Prior to this visit, the inspector should query MISLE for any information on the vessel and pay special attention to any outstanding requirements or casualty information that is available.

## USCG Marine Safety Manual, Vol. II: Materiel Inspection

**SECTION B: DOMESTIC INSPECTION PROGRAMS****CHAPTER 3: HULL EXAMINATIONS**

- (2) While aboard the vessel, the inspector should interview the chief engineer and/or the master, as appropriate depending upon the class of vessel, to obtain their opinions on the condition of the vessel's hull, tailshaft(s), and associated machinery. In addition, the inspector must obtain a written statement from the chief engineer, master, or both, attesting that the vessel is in suitable condition for operation during the period of extension requested.
- (3) The inspector should then examine the vessel to the extent necessary to ensure that the condition of the vessel is, in his or her opinion, satisfactory for the extension requested and does not contradict the opinion of the master or chief engineer. The inspector should also examine the vessel's bridge record card, if applicable, for any deficiencies that may have been issued recently by another port and not yet entered into MISLE.

**NOTE:** The requirement for a written statement is in addition to the owner's written request for DE extension.

- c. Additional considerations for extension. A request for an extension of a hull exam must include an inspection of the vessel and also take into consideration other U.S., international, and class requirements. Any conflicts with other requirements must be resolved before an extension request is forwarded to Commandant (CG-CVC) or granted by the OCMI per Subparagraph A.4.d of this Chapter.
  - (1) International Convention for the Safety of Life at Sea (SOLAS). SOLAS requires an examination of the outside of a ship's bottom every 12 months on passenger vessels and at intervals not to exceed 5 years on all tankers. In addition, SOLAS requires that tankships 10 years of age and older undergo an examination of the outside of the ship's bottom at the required intermediate survey, which may take place between 6 months before and 6 months after the midpoint of the period of validity of the Cargo Ship Safety Construction Certificate. A Cargo Ship Safety Construction Certificate must not be extended beyond 5 years.
  - (2) Load Line Regulations (46 CFR Part 42). The Load Line regulations require a vessel to be drydocked before issuance of a new Load Line Certificate and then every 5 years thereafter. An existing Load Line Certificate may be extended up to 150 days maximum, except for those vessels with Great Lakes Load Line Certificates, which can be extended for up to 365 days. (Until MSM Volume IV, Technical, COMDTINST M16000.9 (series) is updated; see MSM Volume II, Mechanical Inspection, COMDTINST M16000.7A (series), Chapter E4 for policy on load line extensions.)

**SECTION B: DOMESTIC INSPECTION PROGRAMS****CHAPTER 3: HULL EXAMINATIONS**

- (3) Tailshaft examination. The tailshaft examination requirements of 46 CFR 61.20-17 through 61.20-23 and D of this chapter provide regulatory and policy guidance on tailshaft examinations. A tailshaft examination extension may also require consideration if a drydock examination extension will delay the tailshaft exam.
- d. Delegation of extension authority. The Commandant has delegated limited authority to extend hull examination intervals for certain specific vessels to OCMI and district commanders, as follows:
- (1) Tank barges, not gas freed and not in service. Under current industry needs, a large number of not gas-freed tank barges with current COIs have been laid-up for indefinite periods of time. The OCMI is authorized to grant consecutive 12-month extensions of hull examinations for laid-up tank barges, not to exceed a total of 4 years from the original drydock due date. Each extension must be subject to the following:
- (a) The barge must maintain a valid COI, including annual and periodic inspections.
  - (b) In addition to meeting the requirements of 46 CFR 35.05-15, the barge must be boarded and checked for damage and/or cargo tank integrity at least once a week by an owner's representative.
  - (c) A Vessel/Facility Inspection Requirements, Form CG-835 must be issued requiring the barge to undergo all required hull examinations prior to being placed in service, with an expiration date to coincide with the expiration date of the COI.
  - (d) At the end of the fourth lay-up extension, the barge must undergo all required hull examinations and associated repairs made, or its COI must be surrendered.

**NOTE:** The barge must be gas free prior to the surrender of the COI.

- (2) Extension of the CTIE (gravity tanks only) and ISE.
- (a) At the vessel owner's request, OCMI may grant two 12-month extensions to all vessels that require these exams to effect coincidence with a regularly scheduled DE.

## USCG Marine Safety Manual, Vol. II: Materiel Inspection

**SECTION B: DOMESTIC INSPECTION PROGRAMS****CHAPTER 3: HULL EXAMINATIONS**

- [1] In most cases, 24 months should be a sufficient period of time to attain alignment. If a gap of more than 24 months exists between the next CTIE, ISE, and DE due dates, then an effort should be made to conduct either the CTIE or the ISE, or both, early to align them with the DE interval.
- [2] Prior to granting an extension, an external exam should be made of the barge, including an exam from topside of all wing voids and rakes. This exam should be of sufficient scope that the OCMI is satisfied that the CTIE and ISE can be delayed for 12 months.
- (b) Once harmonization of the DE, CTIE, and ISE intervals is achieved, further extensions of the CTIE and ISE longer than 3 months should not be necessary and should not be considered, except in those cases where unusual circumstances exist, e.g., those beyond the control of the owner.
- (c) When an exam is completed following a 3-month extension, the examination completion/credit date must be back-dated to its original due date in order to keep future hull exams in phase with the DE interval.
- (3) For vessels subject to 46 CFR Part 151 with gravity tanks carrying those products with a "G" in the last column of 46 CFR Table 151.05, the cargo tank internal inspection intervals in 46 CFR 151.04-5(b)(1) and (2) and the cargo tank external inspection interval in 46 CFR 151.04-5(c) may be extended as follows:
- (a) The 2-year cargo tank internal inspection interval for single hull barges and internally framed gravity tanks on double hull barges in 46 CFR 151.04-5(b)(1), and the 4-year cargo tank internal inspection interval for externally framed gravity tanks in 46 CFR 151.04-5(b)(2), may be extended to coincide with the appropriate CTIE interval specified in the tables in the applicable 46 CFR Paragraphs; 46 CFR 31.10-21(a), 31.10-21(b), 91.40-3(a), and Table 91.40-3(b), as appropriate.
- (b) The 2-year cargo tank external inspection interval in 46 CFR 151.04-5(c) (applicable to single hull, internally and externally framed double hull tank barges, and single hull barges with independent tanks) may be extended to coincide with the appropriate ISE interval specified in the tables in the applicable 46 CFR Paragraphs; 46 CFR 31.10-21(a), 31.10-21(b), 91.40-3(a), and Table 91.40-3(b).
- (c) The guidance in Subparagraph A.4.d(2) above is also applicable to these tanks carrying "G" products.

**SECTION B: DOMESTIC INSPECTION PROGRAMS****CHAPTER 3: HULL EXAMINATIONS**

**NOTE:** This cargo tank internal and external exam extension authority is only applicable to those products carried in gravity tanks for which 46 CFR Table 151.05 refers to 46 CFR 151.04-5(b) for CTIE intervals (those products carried in gravity tanks with a "G" in the last column of 46 CFR Table 151.05).

- (4) Externally framed cargo tanks on double hull tank barges. OCMIs are provisionally authorized to extend the CTIE intervals from 5 to 10 years on double hull barges that are externally framed with the exception of the deck (see the definition for externally framed cargo tanks in Subparagraph B.6.d.(2) of this Chapter). OCMIs must report to Commandant (CG-CVC) any significant findings regarding under deck framing in both externally framed tanks examined at the 10-year interval, when authorized, and internally framed tanks examined at the 5-year interval.
- (5) Fuel oil tank examinations. Fuel oil tank examinations are required at 5-year intervals during an ISE. If an ISE extension is granted per subparagraph A.4.d(2) above, the fuel oil tank exam should likewise be extended.
- (6) Small passenger vessels. OCMIs may grant DE extensions for T-Boats for a period up to a maximum of 1 year once applicable procedures under subparagraph MSM Volume II, Material Inspection, COMDTINST M16000.7A (series), B3.A.4.b above have been met.
- (7) DE extensions for mobile offshore drilling units (MODUs).
  - (a) Upon completion of the procedures in subparagraph A.4.b above, OCMIs may grant DE extensions for a period of up to 6 months, and district commanders may grant a second 6-month extension. The maximum period of time that a DE interval may be extended is 12 months.
  - (b) MODUS in layup. District Commanders may grant extensions of exam intervals beyond 3 years for laid-up MODUs, provided that the MODU maintains a current COI and its owner or operator submits a letter attesting to the MODU's safe condition.

[1] A Vessel/Facility Inspection Requirements, Form CG-835 should be issued to extend the DE and/or special underwater intervals until the MODU either returns to service or the COI expires. In no case should the expiration of the Vessel/Facility Inspection Requirements, Form CG-835 be beyond the expiration of the COI.

## USCG Marine Safety Manual, Vol. II: Materiel Inspection

## SECTION B: DOMESTIC INSPECTION PROGRAMS

## CHAPTER 3: HULL EXAMINATIONS

[2] A deficiency letter must be sent to the vessel owner to require completion of the appropriate exam prior to the vessel returning to service or renewing the COI, whichever occurs first.

(8) Great Lakes vessels. The Commander, Ninth Coast Guard District, is authorized to grant DE extensions for Great Lakes vessels under the following guidelines:

- (a) Extensions must not exceed 365 days.
- (b) Extensions should be considered on a ship-by-ship basis and will be based on the results of a non-credit ISE, the extent of which should be to the satisfaction of the Commander, Ninth Coast Guard District.
- (c) The Great Lakes load line assignment authority has been notified and there are no outstanding conditions that would impact the decision for the extension.

(9) Inland passenger vessel special drydock extension criteria. Drydock extensions of up to 30 months are available to inland passenger vessels that operate on restricted routes in a benign environment. Such extensions require the vessel to successfully complete a special drydock extension survey. The survey criteria outlined below is similar to the traditional underwater survey program presented in Navigation and Vessel Inspection Circular (NVIC) 1-89 with the exception that it is more detailed and comprehensive.

(a) Eligibility criteria.

[1] Any passenger vessel (inspected under 46 CFR Subchapter H, K, or T) that requests a drydock extension beyond 1 year must meet the following criteria:

- aa. The vessel must be constructed of steel or aluminum. Wood and FRP hulls are excluded from eligibility.
- bb. The vessel must have operated exclusively in fresh water since its last drydock examination. (To further clarify, this means year-round operation in fresh water.)
- cc. Vessel operation must be restricted to rivers or protected lakes. This restriction must be indicated on the vessel's COI. The definition of a protected lake will be left to OCMI discretion.

**SECTION B: DOMESTIC INSPECTION PROGRAMS****CHAPTER 3: HULL EXAMINATIONS**

dd. The vessel must operate exclusively in shallow water or within 0.5 nm from shore. For shallow water operation, the maximum water depth may be defined as the depth at which, if the vessel sinks, the uppermost deck(s) that could safely accommodate all passengers and crew remains above water. To make this determination, vessel stability (passenger heeling moment) must be considered.

**NOTE:** Water clarity is not included as a condition of eligibility. If water clarity is a problem, then the use of a clear box of at least 18 inches in diameter must be used for the underwater video.

[2] The cognizant OCMI will determine eligibility for drydock extensions. In addition to the above criteria, decisions of acceptability will be based on the following:

aa. The overall condition of the vessel (based on inspection history) and the hull protection system (cathodic protection is required, as a minimum).

bb. The vessel's history of casualties involving the hull and other hull-related deficiencies.

cc. Review of the written extension request.

**NOTE:** Although a vessel age limitation has not been included as a criterion, the OCMI must consider the impact of vessel age on the overall condition of the hull when determining vessel eligibility.

[3] Unlike the traditional underwater survey program, a pre-survey drydocking is not required. Permanent hull markings, hinged sea chest grates, and reference videos are optional.

(b) Drydock extension applications. The information required for the drydock extension application is identical to the requirements for the traditional underwater survey program (see Section 2 of End. (1) to NVIC 1-89), with the following exceptions:

[1] Hull maintenance and condition assessment program. The extension request must include a hull maintenance and condition assessment program which must, as a minimum, contain the following:

## USCG Marine Safety Manual, Vol. II: Materiel Inspection

**SECTION B: DOMESTIC INSPECTION PROGRAMS****CHAPTER 3: HULL EXAMINATIONS**

- aa. A preventative maintenance plan for the vessel's hull and related systems/equipment. A preventative maintenance plan should consider the following:
  - (i) Inspection and replacement (as needed) of zinc anodes.
  - (ii) Inspection and cleaning (as needed) of the underwater hull.
  - (iii) Inspection and maintenance of rudder and shaft seals.
  - (iv) Inspection and operational testing of sea valves.
  - (v) Flushing of sea chests and sea strainers.
- bb. Provisions for an annual condition assessment of the hull in the presence of a third party examiner.
  - (i) The third party examiner should be a qualified marine surveyor (recognized by a national marine surveyor association) or have prior experience as a Coast Guard marine inspector or classification society surveyor. As a minimum, the third-party examiner should have at least 3 years experience in the examination of steel or aluminum-hulled vessels.
  - (ii) The OCMI has the discretionary authority to accept or deny the use of a particular third party examiner and may, as an option, require the presence of a marine inspector. The condition assessment plan should include the following:
    - (aa) Evaluation of the vessel's underwater hull and appurtenances (using qualified divers and appropriate video equipment). This is primarily to verify that hull coatings remain intact and check for fouling of hull appurtenances. This can also be used as an opportunity for preventative maintenance.
    - (bb) Hull gaugings (representative sampling) of suspect areas.
    - (cc) A mechanism for providing a written hull assessment and preventative maintenance report or checklist to the cognizant OCMI on an annual basis.

[2] Internal structural examination. A thorough ISE must be conducted during the survey. All internal spaces must be made accessible for examination and gas-freed as appropriate. However, integral fuel oil tanks must be



## SECTION B: DOMESTIC INSPECTION PROGRAMS

## CHAPTER 3: HULL EXAMINATIONS

examined as required by 46 CFR 71.53, 115.610, or 176.610 (as applicable).

[3] Vessels of 15 years of age or older. Vessels 15 years of age or older are eligible for drydock extensions under this policy.

(c) Preparatory meeting. Before conducting the drydock extension survey, a preparatory meeting must be held. See Section 4 of Encl. (1) to NVIC 1-89 for details.

(d) Survey criteria. The drydock extension survey must be conducted in accordance with Section 5 of End (1) to NVIC 1-89, with the following additions or modifications:

[1] Duration of the drydock extension survey. The survey should take as long as the inspector considers necessary to ensure that the ship is in a safe condition to continue operation for the next 30 months. At least 5 days should be allowed to conduct the examination. However, with use of a third party examiner, the marine inspector's time on-site may be reduced. With the exception of those portions of the survey that require marine inspector presence, the duration and scope of participation by a marine inspector must be subject to OCMI discretion.

[2] Site selection. The site must be in an area with sufficient water depth under the keel and sufficient clearance adjacent to both sides of the vessel to allow the diver to safely survey the entire underwater hull of the ship. Current velocity must be minimal to ensure diver safety. If air temperatures are below freezing, dive equipment must be designed for use in sub-freezing conditions. Diving should not take place when ice exists on the water surface.

**NOTE:** Water clarity is not a great concern because use of a "clear box" will enable a clear, albeit limited, view of the hull regardless of water conditions.

[3] Hull markings. If permanent hull markings required by NVIC 1-89 are not in place, a temporary underwater grid system must be used. The temporary grid system must consist of stainless or galvanized steel cables, spaced not more than 10 feet apart, with sequentially numbered tags spaced at 1-foot intervals. The grid system must remain in place during the entire survey.

[4] Preliminary examination. Prior to holding the preparatory meeting as noted in Section 3 of NVIC 01-89, a third-party examiner (acceptable to the OCMI) together with qualified divers must conduct a preliminary

## USCG Marine Safety Manual, Vol. II: Materiel Inspection

**SECTION B: DOMESTIC INSPECTION PROGRAMS****CHAPTER 3: HULL EXAMINATIONS**

examination of the hull. The preliminary examination must be used to assess the overall condition of the vessel hull and identify specific concerns that should be addressed. A marine inspector does not need to be present during this portion of the survey process.

[5] Underwater inspection. A complete underwater hull examination (as defined below) must be supervised by the third-party examiner and recorded on videotape. The third-party examiner will identify areas requiring further examination by a marine inspector. The videotape will be indexed to enable the marine inspector to readily identify and review important sections of the tape.

- aa. As a minimum, the underwater survey must include a general examination of the hull plating and a detailed examination of all hull welds, propeller, rudder, other hull appurtenances, sea chests, and sea valves. As a guide, examination of the hull plating should cover all welds and at least five points on each plate, evenly spaced, where ultrasonic gaugings will be taken. The plugging of sea chests and gauging of rudder and tailshaft bearings must also be recorded on videotape. The attending marine inspector may require a detailed examination of other areas of the hull as deemed necessary.
- bb. In addition to the above gaugings, divers must take belt gaugings at the bow, stern, and midships and along the wind and water strake. The number and exact location of belt gaugings will be subject to OCMI discretion.
- cc. A Coast Guard marine inspector must be present during critical portions of the underwater survey process. Critical portions include, as a minimum:
  - (i) Examination of critical welds (identified at preparatory meeting), propeller, rudder, other hull appurtenances, sea chests, and sea valves.
  - (ii) Plugging sea chests and removal of sea valves.
  - (iii) Gauging of rudder and tailshaft bearings.
  - (iv) Any other portions identified by the OCMI.
- dd. Sea valves must be removed and examined in accordance with the guidance in NVIC 1-89. The OCMI must be completely satisfied that

**SECTION B: DOMESTIC INSPECTION PROGRAMS****CHAPTER 3: HULL EXAMINATIONS**

sea valves can be removed safely. Passengers must be removed from the vessel during this evolution.

ee. This special drydock extension program is an option that the vessel's owner/operator has elected to use. Responsibility for the management of the vessel, its personnel, and maintenance of necessary safety and service systems remains at all times with the master and owner/operator.

ff. The vessel owner must provide the OCMI with a detailed examination report, including a gauging report, bearing clearances, and a copy of the videotape.

[6] Underwater inspection techniques and equipment. Underwater inspection techniques and equipment must be in accordance with Section 5 of Encl. (1) to NVIC 1-89. If water visibility will affect the quality of the underwater video, the video camera must incorporate use of a "clear box."

aa. A clear box is a device which uses clean, fresh water to displace the surrounding water and provide a clear view for the camera. In order to provide an adequate field of view, the clear box must measure at least 18 inches in diameter (or, if rectangular, at least 18 inches in height and width).

bb. As a general rule, modern video and audio equipment must be used to assure the best quality results.

[7] Internal Structural Examination (ISE) and integral fuel oil tank examination. A complete ISE must be conducted as part of the drydock extension survey. All internal areas of the hull must be accessible for examination.

## USCG Marine Safety Manual, Vol. II: Materiel Inspection

**SECTION B: DOMESTIC INSPECTION PROGRAMS****CHAPTER 3: HULL EXAMINATIONS**

- aa. The marine inspector must conduct the entire ISE. The third-party examiner or a suitable representative will accompany the inspector to take additional hull gaugings. The extent of internal gaugings should be limited to that necessary to confirm the information gathered during the underwater survey.
  - bb. Integral fuel oil tanks must be examined as required by B.5 of this Chapter and 46 CFR 71.53, 115.610, or 176.610 (as applicable).
- [8] Acceptable underwater repairs. The acceptance of underwater repair proposals and the actual repairs is subject to OCMI discretion.
- aa. Repairs using underwater welding must be subject to periodic reevaluation at subsequent inspections. Such repairs must be completed in accordance with the standards found in the American Welding Society's "Specifications for Underwater Welding."
  - bb. The OCMI may require immediate drydocking of the vessel if an underwater repair proposal or the actual repairs are considered unsatisfactory.
- [9] Evaluating results of the survey. The OCMI may require drydocking of the vessel at any time if not satisfied with the results of the drydock extension survey.
- [10] Administrative procedure. If fully satisfied with results of the survey, the attending marine inspector may recommend a drydock extension of up to 30 months.
- aa. The drydock extension policy in A.4 of this Chapter must be followed for administrative purposes. Based on results of the survey, the OCMI may recommend a drydock extension of up to 30 months.
  - bb. Each completed application and survey, with the OCMI's recommendation, must be forwarded to Commandant (CG-CVC), via District, for action. Commandant (CG-CVC) has final approval authority for drydock extensions submitted in accordance with this policy.
- [11] Tank vessels, tank barges, and freight vessels. District Commanders may grant DE interval extensions for these vessels under the following guidelines:

**SECTION B: DOMESTIC INSPECTION PROGRAMS****CHAPTER 3: HULL EXAMINATIONS**

- aa. The extension period must not exceed 3 months. DE extensions beyond 3 months may only be granted by Commandant (CG-CVC). Requests for all extensions must be forwarded with recommendations to the appropriate office, via the chain of command.
- bb. In all cases where an extension is granted (except for Great Lakes vessels), the extension date will be the new drydock base date. That date will be back dated to the actual DE due date.
- cc. In all cases (except for DE extensions for 30 days or less), the OCMI will conduct a pre-drydock extension examination to determine the material condition of the vessels. OCMI recommendations concerning the DE extension requests must be forwarded with the DE extension request for further consideration.

- [12] Guidance for drydock examination interval extensions. The revised drydock regulations require that certain vessels in salt water service be examined on drydock twice within any 5 year period, with no more than 3 years between any two examinations. This requirement prevents a vessel from ending a 5-year drydock period with a 3-year interval between dockings and beginning the next period with another 3-year interval.
- [13] Extensions of drydock examination intervals. Extensions to drydock examination intervals will not normally be considered, except under unusual circumstances. Examples of unusual circumstances are the sudden unavailability of drydock space (e.g., due to high river stage, weather damage to facilities, or the scheduled drydock facility unexpectedly going out of business), the employment of the vessel where it cannot be replaced without risk, or circumstances clearly beyond the owner's control. Singularly, financial hardship is not a valid reason for granting a drydock extension. Requests for drydock examination interval extensions forwarded to Commandant (CG-CVC) should be sent via the chain of command with endorsements that provide recommendations. The recommendations made by the OCMI and the District (p) officer are necessary to properly evaluate the request. Every effort should be made by the OCMI to ascertain and indicate the material condition of the vessel in question.

**SECTION B: DOMESTIC INSPECTION PROGRAMS****CHAPTER 3: HULL EXAMINATIONS**

- e. Administering extensions. If an extension is granted, it should extend the affected exam to no later than the date to which the extension was requested, or shorter if necessary to meet other requirements discussed above. MISLE must be updated accordingly to reflect the extension dates. If the OCMI deems it appropriate, the COI should be reissued with a statement under "Conditions of Operations" reflecting that hull exams have been extended.

---

**5. Documenting Freshwater Service**

- a. The OCMI should require whatever documentation considered necessary to ensure that only vessels that qualify for a fresh water DE exam interval receive one. Upon acceptance of satisfactory documentation of fresh water service, the OCMI should allow a longer DE interval as provided by the regulations for fresh water service and amend the COI accordingly. The vessel's service should be evaluated annually for extensions up to the standard intervals allowed for fresh water service.
- b. OCMI's may add a "Fresh Water Only" restriction to a Lakes, Bays, and Sounds route endorsement as an alternative to requiring letters that document fresh water service. These route restrictions should be made only at the request of the vessel owner. Due to the length and detail of modern COIs, lengthy route endorsements or restrictions to limit salt water exposure are discouraged.

---

**6. Impact of Lay-Up on Hull Examination Schedules**

The following apply to vessels with a 2.5-year DE interval that are drydocked when they come out of a lay-up period:

- a. A vessel for which the lay-up period exceeds 6 months is subject to the following criteria if more than 2 years have elapsed since its last drydocking:
- (1) The hull exam cycle when coming out of lay-up will start anew with the re-activation hull exams. The next hull exam will be required between 2 and 3 years after the activation DE, the actual date being the owner/operator's choice.
  - (2) All hull examinations, i.e., DE, ISE, CTIE, underwater survey (if approved by the OCMI and applicable), and tailshaft exam, are included.
- b. For a vessel coming out of a lay-up period of less than 6 months, when more than 3 years have elapsed since the last drydocking, the next required drydocking need not be less than 2 years.

**SECTION B: DOMESTIC INSPECTION PROGRAMS****CHAPTER 3: HULL EXAMINATIONS**

- c. Vessels coming out of lay-up periods of any length, but for which less than 3 years have elapsed since the last DE, must be subject to the normal 2.5-year hull exam intervals.

---

---

**B. CONDUCT OF HULL EXAMINATIONS**

Vessel owners or operators are responsible for preparing the hull, through-hull fittings, shaft(s), propeller(s), rudder, tanks, voids, and other confined spaces, as appropriate, for any hull examination. This includes cleaning, disassembling, gas freeing, testing for toxicity, and ventilating.

The inspector should normally conduct the examinations in the company of a vessel representative (port engineer, ship's officer, etc.), as well as any other interested parties or agencies (a classification society surveyor, an insurance underwriter, a shipyard representative, etc.). Whether accomplished in one visit or over a period of time, each particular exam should consist of a careful inspection of all accessible parts of the vessel's structure, fittings, and appurtenances, as appropriate.

The inspector should call deficiencies to the attention of the owner's representative at once. When deemed necessary, the inspector should note requirements for correction of deficiencies on Vessel/Facility Inspection Requirements, Form CG-835. Discussion of the vessel's condition and alternate methods of repair should result in adequate repairs with the least disagreement over methods and extent of repair.

The marine inspector must be satisfied that the vessel can operate safely. In cases of severe damage, controversy, or unusual circumstances beyond the inspector's experience, the OCMI should be notified immediately.

---

**1. References**

NVIC 7-68, "Notes on Inspection and Repair of Steel Hulls," contains guidance on judging the condition of and making repairs to steel hulls.

NVIC 7-95, "Guidance on Inspection, Repair and Maintenance of Wooden Hulls" contains guidance on repair of wooden hulls.

Inspectors must be familiar with the recommended procedures in these [NVICs](#).

MSM Volume II, Material Inspection, COMDTINST M16000.7A (series), Chapter A5 contains inspection and repair standards for tank barges.

**SECTION B: DOMESTIC INSPECTION PROGRAMS****CHAPTER 3: HULL EXAMINATIONS**

MSM Volume I, Administration and Management, COMDTINST M16000.6 (series), Chapter 10, contains Coast Guard occupational safety and health policy for marine safety personnel.

NVIC 5-82, "Fixed Ballast," contains guidance on permanent ballast tanks, corrosion inhibitors, test plates and ballast mediums.

---

**2. Drydocking Exam for Credit**

All vessels in drydock must be cleaned and their fittings opened to the extent necessary for the inspector to determine the condition of the underwater body and fittings. Past casualties have indicated a need to examine fittings in the underside hull that might be hidden by keel blocks. When it is known that docking plugs are fitted in the hull, the inspector should ensure that they are also inspected when the vessel is in drydock.

- a. Drydocking in excess of requirements. When a vessel is drydocked for repairs to the underwater body or fittings, or for other purposes in excess of the requirements for complete periodic inspections, an examination should normally be made by an inspector.
    - (1) This examination should be sufficient to determine that all repairs are adequate and that the vessel is safe for continued operation. If the owner or operator requests credit for a drydocking after the vessel has already been hauled out, a complete examination for credit should be conducted if the OCMI has the resources available to dedicate an inspector to the job.
    - (2) If the drydocking is not for full credit, the inspector should examine the underwater hull structure and fittings to the fullest extent practicable under the circumstances. In such cases, the degree of preparation and opening of fittings may be less in scope. This policy does not prevent the inspector from conducting such reasonable inspections or requiring reasonable cleaning or opening of fittings, as deemed necessary to determine that the vessel's condition is safe for continued operation. However, excessive or arbitrary requirements for the cleaning or opening of fittings are not desired.
  - b. Drydocking of T-Boats. For vessels inspected under 46 CFR Subchapter T, an inspector need not attend every drydocking that is not for full credit. An inspector must attend each of the periodic drydockings required by 46 CFR 176.600.
-



**SECTION B: DOMESTIC INSPECTION PROGRAMS****CHAPTER 3: HULL EXAMINATIONS****3. Internal Structural Exam (ISE)**

The ISE requirement is in addition to the statutory requirement to determine the suitability of the hull structure at the time of a vessel's COI, as required per 46 U.S.C. 3305 and 3307.

The scope of an examination of the vessel's structure during an inspection for certification that does not include a DE is left to the discretion of the OCMI. The OCMI should use the results of the more recent ISEs when assessing the suitability of the structure for the intended service at the time of certification. This concept is not new and has essentially been applied anytime a COI was issued as the result of an inspection that did not include a drydocking.

---

**4. Cargo Tank Internal Exam (CTIE)**

The scope of the CTIE exam consists of an examination of the internals of all cargo tanks, including, but not limited to, framing, piping, sounding devices, closure devices, and all attached appurtenances. This exam does not extend to pressure vessel type cargo tanks, which are being addressed in a separate regulatory project.

---

**5. Internal Examination of Integral Fuel Oil Tanks**

In order to promote safety and to comply with the recommendations of the National Transportation Safety Board resulting from the sinking of the GLOMAR JAVA SEA, the internal examination of integral fuel oil tanks is now required.

- a. Timing. The fuel oil tank examination intervals are structured to permit alignment with the similar load line requirements (46 CFR 42.09-15) and the ABS special survey standards (e.g., our regulations require ABS third special survey standards to be met by vessels 10 years of age or more but less than 15 years of age). This 5-year window, and other similar windows, will enable vessel owners to schedule fuel tank examinations as required with the vessel's ISE, or to coincide with the DE, if desired.
  - b. Selection of tanks to be internally examined. As with the ABS Rules, the mandatory internal inspection of a representative sampling of fuel oil tanks only applies to double bottom tanks. Integral non-double bottom fuel oil tanks do not need to be cleaned out and internally examined if the marine inspector is able to determine by external examination that the general condition of the tanks is satisfactory. When selecting those tanks to be internally examined, due consideration should be given to the results of the external fuel oil tank examination as well as previous inspection records to ensure that, as appropriate, a variety of tanks are entered during the life of a vessel.
-

## USCG Marine Safety Manual, Vol. II: Materiel Inspection

## SECTION B: DOMESTIC INSPECTION PROGRAMS

## CHAPTER 3: HULL EXAMINATIONS

**6. Examination of Tank Vessels**

- a. Introduction. Coast Guard inspectors focus their attention on certain unsatisfactory conditions found on tankships as a result of casualties, information furnished through crew complaints, and individual examinations of vessels by headquarters representatives. These include the following:
- (1) Deteriorated underdeck and side shell longitudinals.
  - (2) Fractures in bottom transverses, bilge brackets, and web frames, particularly in areas where stress raisers are found, i.e., "notches" caused by rat holes, lap joints, square cutouts, and improperly radiused transitions.
  - (3) Severe general wastage of internals in tanks or compartments exclusively used for ballast or as cofferdams.
  - (4) General wastage by corrosion of deck piping, expansion trunks, and pipe brackets.
  - (5) General wastage and severe binding of the required remote control reach rods.
  - (6) Deterioration of through hull fittings, spool pieces, and expansion joints.
- b. Hull examinations. The findings noted above, coupled with observations of the overall condition of several older tankers, indicate that the scope and caliber of inspections have occasionally been unsatisfactory. To ensure complete coverage of a vessel of any age during an inspection cycle, the scope of DEs, ISEs, CTIEs, underwater surveys, integral fuel oil tank examinations, inspections for certification, annual and periodic inspections should be recorded as follows:
- (1) The inspector should sign the "Remarks" section of Inspection Books, CG-840, after indicating each internal compartment that was not examined and why.
  - (2) Signed entries should be made on Vessel Inspection Record, Form CG-2832, indicating each internal compartment that was examined.

**SECTION B: DOMESTIC INSPECTION PROGRAMS****CHAPTER 3: HULL EXAMINATIONS**

**NOTE:** Inspections of double bottom and other tanks and cofferdams should be carried out during internal structural examinations, although such spaces may be inspected during an inspection for certification, annual inspection, periodic inspection, or drydocking. In all cases, all gas-free compartments of ocean and coastwise tankships (with the exception of fresh water tanks) should be examined internally at vessel DEs, underwater surveys (if approved and applicable), ISEs, CTIs, integral fuel oil tank examinations, inspections for certification, annual and periodic inspections. If, at the time of an inspection, the OCMI is not satisfied that these compartments were examined during the previous inspection, an appropriate gas-freeing requirement should be made to permit such examination.

- c. OCMI should consult MISLE or contact one another to obtain appropriate records to ensure that internal compartments are examined as required.
- d. In addition, the OCMI should take such steps as considered necessary to ensure that thorough examinations are made to detect the conditions described in subparagraph B.6.a above. Particular care should be taken to examine all structural members and areas subject to wastage by corrosion from cargoes or salt water.
- e. Examination of vessels built with reduced scantlings.
  - (1) Very Large Crude Carriers (VLCCs) and Ultra Large Crude Carriers (ULCCs) present a unique inspection problem due to their size, lighter construction, and susceptibility to corrosion.
    - (a) Experience has shown that vessel age is a much more important factor for inspection of VLCCs than for conventional tankers. Vessels built to reduced scantling standards should be indicated by a special notation on their COI. These vessels have less corrosion allowance and are required to have tank coatings as a condition of construction. The proper use of thickness gauge readings and inspections of tank coatings and corrosion control systems are therefore very important.
    - (b) Accelerated corrosion loss has been prevalent in cargo/dirty ballast tanks, flume openings, and bottom shell plating. Crude Oil Washing (COW) has also presented localized wastage problems due to direct impingement of crude and cleaner on surfaces. Tank coating conditions must be noted in the inspection narrative and coating restoration will be required if existing coatings have failed.

## USCG Marine Safety Manual, Vol. II: Materiel Inspection

## SECTION B: DOMESTIC INSPECTION PROGRAMS

## CHAPTER 3: HULL EXAMINATIONS

- (2) CTIE. The size of cargo tanks on ULCCs and VLCCs presents a special problem in the examination of underdeck structural members.
- (a) Methods of conducting an inspection have included rafts, high-powered lights with binoculars, special cranes, and catwalks. Although enhanced special surveys require “close up” inspections, conventional climbing about with a flashlight or staging methods are neither safe nor practical in larger cargo tanks. The method of tank inspection should be discussed and approved in advance of the vessel's scheduled inspection whenever possible.
  - (b) The raft method can be hazardous and should be conducted only with the OCMI's specific approval.
  - (c) Catwalks or other permanent in-tank structures may not be safe due to weakening from accelerated corrosion.
- f. Tank barge examinations.
- (1) The longer drydock intervals were established with the intent that the required intermediate ISEs would be thorough. It is imperative that a complete examination of internal framing, hull plating, and tank boundaries in the void and ballast spaces is conducted. The regulations allow an OCMI to require a vessel to be drydocked or otherwise taken out of service, if, during an ISE, damage or deterioration to the hull plating or structural members is discovered.
  - (2) Externally framed tanks. The 10-year CTIE interval permitted for double hull barges with externally framed gravity cargo tanks is applicable to those tanks that are externally framed on both ends, both sides, bottom, and top. Double hull barges with framed bulkheads in the cargo tanks, or with trusses, girders, or stanchions in the cargo tanks, qualify for the externally framed intervals as long as the exterior cargo tank envelope is externally framed (all six sides). In addition, on an interim basis pending inspection results per Subparagraph A.4.d(4) above, double hull barges that are externally framed with the exception of the deck must be considered to be externally framed. This policy must be applied to all 46 CFR Subchapter D and I double hull barges, and to those carrying 46 CFR Subchapter O products that have a "G" in the last column of 46 CFR Table 151.05.
-

**SECTION B: DOMESTIC INSPECTION PROGRAMS****CHAPTER 3: HULL EXAMINATIONS****7. Examination of Permanent Fresh Water Ballast Tanks**

Ballast tanks containing permanent freshwater ballast may be exempted from internal inspection under the following conditions.

- a. The ballast fluid is chemically tested to ensure that its corrosion-inhibiting properties are still effective. The test sample should be taken from mid-depth in the ballast tank.
- b. The corrosion test plate is examined to ensure that the ballast tanks are free of corrosion.
- c. An external examination of each ballast tank, to include bottom shell plating, tank top, and all internal structural members that constitute the exterior of the ballast tank, is conducted to the extent practicable to determine the external condition of the ballast tank.

**NOTE:** When significant corrosion is found, structural damage is evident, or the permanent ballast medium is determined to be inadequate, the OCMI may require that the subject tank be made gas-free (if necessary) and available for internal inspection.

---

**C. UNDERWATER SURVEYS INSTEAD OF ALTERNATE DRYDOCK EXAMINATIONS**

In December 1980, the Coast Guard published a research report, "1980 Underwater Technology Survey for Extension of Time Between Drydockings" (National Technical Information Service (NTIS) Report ADA 101-131). This report indicates that current technology, properly applied with additional administrative and operational controls, can provide a satisfactory means of inspecting the underwater bodies of vessels without them being hauled out.

Underwater examinations using video equipment have been accepted on occasion by the Coast Guard as a means of verifying the continuing acceptability of the structure of large MODUs since 1969.

Since publication of 46 CFR Part 107 in 1978, underwater examinations for column-stabilized and self-elevating MODUs have been allowed by regulation.

The revision of the drydock and tailshaft regulations in 1988 provide the option of alternating DEs with underwater surveys to owners and operators of tank vessels, cargo and miscellaneous vessels, and oceanographic research vessels less than 15 years of age, and also permit continued participation in the underwater survey program for vessels 15 years of age and older.

Vessels older than 15 years of age which have not previously participated in the underwater survey program are still eligible.

**SECTION B: DOMESTIC INSPECTION PROGRAMS****CHAPTER 3: HULL EXAMINATIONS**

---

**1. Entry into Underwater Survey Program**

- a. Pre-survey drydocking. An owner who desires to enter his or her vessel into the underwater survey program must first drydock the vessel. The purpose of this drydocking is to conduct a preliminary survey of the hull to evaluate its condition and the feasibility of conducting an underwater survey. This survey and the video discussed in Subparagraph C.1.d below are to be used as a reference for the first underwater survey once the vessel has been approved for the underwater survey program.
- b. Hull markings. During the pre-survey drydocking, the vessel owner/operator must provide a means whereby the location of the diver relative to the hull can be determined with sufficient accuracy to locate specific points on the underwater body. This may entail a weld bead grid system on the hull, a contrasting color coating system, a movable grid, an acoustic "pinger" locating system, or any other arrangement that is satisfactory to the OCMI. Hull markings, or targets, every 100 feet, at the keel, below the turn of the bilge, and below the water line are recommended. Consideration should be given to the possibility that bottom coatings alone may wear off over time.
- c. Sea chests. Hinged gratings must be installed on all sea chests to allow divers access into each sea chest to inspect the external sides of through hull connections and sea valves.
- d. Reference video. Once all hull markings and preparations have been made, a video tape with audio commentary must be made of all external areas of the underwater hull, including rudder, propeller(s), tailshaft(s), hull protective system, and all other attached appurtenances. The video must clearly show the hull reference markings.

---

**2. Applications for Underwater Surveys Instead of Alternate Drydock Examinations**

Applications for underwater surveys should be submitted to the cognizant OCMI at least 90 days before the requested survey. In addition to the information required by the applicable sections of the CFR cited in C above, each application should include--

**SECTION B: DOMESTIC INSPECTION PROGRAMS****CHAPTER 3: HULL EXAMINATIONS**

- a. Identity of the diving contractor;
- b. Number of divers to be employed, type of diving equipment to be used, and their underwater Nondestructive Testing (NDT) and damage repair capabilities;
- c. Means of waterborne diver support;
- d. Means of taking rudder bearing clearances;
- e. A letter signed by the vessel's master, chief engineer, or the person in charge, stating the general overall condition of the vessel, level of maintenance, any known or suspected damage, cleanliness of the underwater body, and the anticipated draft of the vessel at the time of the survey;
- f. The number of additional or vessel personnel that will be available to assist the dive team and Coast Guard marine inspector in conducting the underwater survey;
- g. The anticipated duration of the underwater survey (experience indicates that at least 5-10 days should be allowed); and
- h. Whether or not ISE, CTIE, and integral fuel oil tank exams as required will be conducted concurrently with the underwater survey.

---

**3. Applications for Continued Participation in the Underwater Survey Program by Vessels 15 Years of Age and Older**

Requests to continue in the underwater survey program for those vessels which will be 15 years of age or older at the time of the next underwater survey must be submitted to Commandant (CG-CVC) via the cognizant OCMI at least 90 days before the drydocking preceding the underwater survey.

This advance notice, which would be 3 to 5 years in advance of the requested underwater survey, is intended to ensure that a thorough assessment of the vessel is made during the drydocking preceding the underwater survey, with an eye towards the vessel's suitability to go twice the drydock interval between actual haul outs.

## USCG Marine Safety Manual, Vol. II: Materiel Inspection

**SECTION B: DOMESTIC INSPECTION PROGRAMS****CHAPTER 3: HULL EXAMINATIONS**

Additionally, advance notice will ensure that a complete set of suitable hull gaugings is taken. A complete set of hull gaugings is considered to be all of the gaugings deemed necessary by the OCMI to determine the condition of that particular vessel's hull. They should include, as a minimum, gaugings taken around two or more complete transverse sections of the hull. Plate gaugings of one or more strakes in the wind and water area, of additional transverse belts, or of questionable areas such as those with heavy pitting or fractures, may also be required.

The results of the drydock examination and the hull gaugings, together with the OCMI's recommendations, must be submitted to Commandant (CG-CVC) for final determination of whether the vessel may remain in the underwater survey program.

---

**4. Preparatory Meeting**

The Coast Guard inspector, a shipowner's representative, and a member of the diving team should conduct a preparatory meeting prior to the underwater survey to discuss the details of the survey. In the case of overseas surveys, every effort should be made to hold this meeting before the inspector proceeds overseas.

At this meeting, the duration of the survey, the site selection, the diver's equipment, personnel and operation, hull cleanliness and preparation, extent of internal examinations, route of the survey along the vessel's bottom, and the overall conduct of the survey should be discussed. In addition, the inspector will be able to advise the shipowner's representative and the diver of all the items the inspector intends to inspect during the underwater survey. Additional items may need to be surveyed depending upon the actual conditions found aboard the ship during the survey.

---

**5. Conducting the Survey**

The following guidelines have been developed based upon Coast Guard underwater survey experience, the NTIS report, and the ABS Guide for Underwater Inspections in Lieu of Drydocking Survey, 1975:

- a. General. As a minimum, an underwater survey should include a general examination of the hull plating and a detailed examination of all critical welds, propeller, rudder, other hull appurtenances, sea chests, and sea valves.
  - (1) Detailed examination of other areas should be conducted as considered necessary by the inspector.



**SECTION B: DOMESTIC INSPECTION PROGRAMS****CHAPTER 3: HULL EXAMINATIONS**

- (2) It must be stressed that the underwater survey program is an option that the ship's owners/operators have elected to use. Responsibility for the management of the vessel, its personnel, and maintenance of necessary safety and service systems remains at all times with the master and his representatives.
- b. Duration of the underwater survey. The underwater survey should take as long as the inspector considers necessary to ensure that the ship is in a safe condition to continue until the next DE (up to 3 years for salt water service and 5 years for fresh water service). Previous experience indicates that at least 5 days should be allowed to conduct the underwater survey. However, if problems develop or repairs become necessary, more time will be required. Initial estimates of the duration of the underwater survey should be proposed by the owner in the application and either refined or confirmed during the preparatory meeting.
- c. Site selection. The location of the underwater survey is of the utmost importance for two major reasons.
- (1) The site must be in an area with sufficient water depth under the keel and sufficient clearance adjacent to both sides of the vessel to allow the diver to safely survey the entire underwater hull of the ship, without concern for the presence of hostile sea life or high current velocities.
- (2) The site must have good underwater visibility. Conducting an underwater survey in poor visibility could adversely affect the outcome of the program (equivalency to a DE) and the safety of the ship. Water turbidity (clarity) is a particularly subjective item, and the decision of acceptability should be based primarily on the clarity of the television monitor presentation. If the inspector feels that better visibility is necessary, the shipowner should be given the option of either moving the ship to a location with better visibility or drydocking the ship.
- d. Additional personnel. Current trends in automation and reduced staffing may result in a situation where a vessel's normal complement will not provide a sufficient number of personnel to assist in the inspection process and maintain the shipboard watch. Additional personnel may be needed to act as line handlers to support the dive boat, to position a movable grid if used, to pull sea valves, etc. Consideration should be given to crew watchstanding responsibilities when evaluating the need for additional personnel.

## USCG Marine Safety Manual, Vol. II: Materiel Inspection

## SECTION B: DOMESTIC INSPECTION PROGRAMS

## CHAPTER 3: HULL EXAMINATIONS

- e. Divers, diving equipment, and operations.
- (1) The underwater survey should not be conducted unless the inspector is satisfied that the divers' equipment and procedures will provide a safe and meaningful examination of the ship. Safety must be foremost on the minds of all those working together on the actual diving operation. While matters in this regard are best left to the experienced, professional individuals normally found conducting this type of work, everyone involved in the survey should be alert to these needs and ensure that any requirements regarding this inspection can be safely accomplished.
  - (2) Acceptability of diving personnel and equipment. The owner should employ a professional commercial diving firm. Specific Coast Guard approval is not required, but a subjective evaluation by the OCMI or the attending inspector should be conducted. Such an evaluation may consider the following:
    - (a) Prior experience or training.
    - (b) Qualifications of dive team members in photography, NDT, underwater damage repair, and other training and experience.
    - (c) The type, quality, and condition of equipment to be used, i.e., a color monitor and color tape video recording system is required along with two-way recorded audio between the diver and the inspector. A still underwater photographic capability must also be available.
    - (d) The degree of professional approach/attitude, as evidenced by an organized dive plan, personnel assignments, standbys and backups, compliance with appropriate safety regulations (Coast Guard, Occupational Safety and Health Administration (OSHA), various states).
- f. Hull preparation. The underwater survey should not begin until the inspector is satisfied that all areas of the hull to be inspected, including sea chests and sea valves, have been cleaned to allow for a meaningful examination. The method of cleaning is left to the discretion of the vessel owner.
- (1) The inspector should review the reference video taken at the pre-survey drydocking to familiarize him or herself with the layout of the hull markings and overall condition of the hull at the time the recording was made.

**SECTION B: DOMESTIC INSPECTION PROGRAMS****CHAPTER 3: HULL EXAMINATIONS**

(2) The internal examination (opening up) of sea valves may require diver installation of custom prefabricated blanks or watertight boxes on through hull fittings. Each hull opening to be blanked or plugged should be permanently marked or identified on the hull. This will simplify verification that blanks are inserted and removed from the correct hull openings. The ship should be at, or as close as possible to, its light draft.

g. Sea valves.

(1) Preparation. The preparation of the sea valves for inspection during an underwater exam is most critical, as it will affect the watertight integrity of the hull and the ability to keep essential machinery in operation. The vessel's personnel should develop and provide a detailed procedure prior to commencing the examination of sea valves. The procedure should, at a minimum, include the following:

- (a) The number, type, size, and method of operating of the sea valves to be opened.
- (b) The disabling of automation features which might affect the sea valves being examined.
- (c) Method of installing blanks/plugs for sea chests/valves.
- (d) A sequence of valves to be blanked/opened that ensures that vital cooling systems, essential electrical service, and bilge and fire pumping capabilities are maintained.
- (e) The closure of watertight doors.
- (f) An emergency procedures plan.
- (g) Means of communication between the bridge, dive team and engine room (direct communications via sound powered phones are preferred).

**SECTION B: DOMESTIC INSPECTION PROGRAMS****CHAPTER 3: HULL EXAMINATIONS**

(2) Safeguards. Removing and examining sea valves while a vessel is afloat and while some portion of the machinery plant remains in operation is a situation not generally experienced by shipboard personnel. Of necessity, all involved personnel should maintain the highest sensitivity to problems which may start out small but could lead to more serious matters. Intentionally disabling some systems is not a typical operation and should be carefully controlled by the ship's personnel. Sometimes the failure of internal safeguards or other construction features can lead to pressure in piping systems thought to be de-pressurized. This condition can lead to lengthy delays while the cause is located and corrected. Points to consider are as follows:

- (a) Interconnected sea chest vents that meet below the water line will subject both sea chests to sea pressure unless both sea chests are blanked simultaneously.
  - (b) Failure of check valves can pressurize secured systems. This would most likely occur in crossovers between main and auxiliary fire pump lines, main and auxiliary cooling systems, and crossovers to the sanitary systems from any other salt water system.
  - (c) Temporary "jumpers" installed to keep essential systems on line may defeat the designed system isolation.
  - (d) Pressurizing auxiliary and sanitary systems with full fire main pressure can damage equipment designed for low pressure service.
- h. Bearing clearances. Readings of the propulsion shaft bearing and rudder shaft bearing clearance should be taken. These readings should be acceptable to the inspector as accurate and reliable. Otherwise, drydocking the ship may be necessary. Clearances should be compared with those obtained during the last examination and meet the standards set in 46 CFR 61.20-23.
- i. ISE, CTIE, and fuel oil tank exam. These exams include an examination of the vessel's main strength members, including major internal framing, hull plating, voids, and ballast tanks. In most situations, the ISE should be conducted before, or at the same time as, the underwater survey. The results of the ISE should be used to identify those areas where a problem exists or is suspect. These areas should be given special emphasis when conducting the external underwater survey.
- j. Repairs and deficiencies. Any required repairs should be performed to the satisfaction of the inspector. Depending upon the magnitude of the repair or the number of repairs necessary, this may result in an unsatisfactory examination and require drydocking of the ship.

**SECTION B: DOMESTIC INSPECTION PROGRAMS****CHAPTER 3: HULL EXAMINATIONS**

- (1) Deficiencies that are not repaired, or are not considered severe enough to require repair, should be evaluated in conjunction with the overall results of the underwater survey in determining whether the ship should be allowed to operate a full interval until the next drydocking.
  - (2) If there is doubt as to whether a ship is in a sufficiently safe condition to operate a full interval until the next drydocking (up to 3 years for salt water service and 5 years for fresh water service), the ship should be drydocked.
- k. Underwater inspection techniques and equipment.
- (1) General. The attending inspector will generally be limited to viewing the television (TV) monitor, reviewing video tapes, talking with the diver, observing NDT procedures, reviewing any still photos, and reading the diver's survey report. This method of survey does not generally lend itself to the flexibility and "hands-on" aspects marine inspectors have come to know at normal haul outs. Nevertheless, there are a number of things that the inspector can and should prepare for.
    - (a) The diving operation will normally be a surface supplied air dive that includes the diver, a tender watching the diver's umbilical, a standby diver (usually the tender), and the diving supervisor. Communications with the diver should be via hardwire.
    - (b) The TV monitor should be located close to the diving supervisor's position to facilitate simultaneous viewing of the TV monitor and communication with the diver.
  - (2) Diver's observations. The diver's visual findings and commentary can be very beneficial. A knowledgeable inspection diver can provide detail and description to greatly enhance the usefulness of the TV monitor's picture. For example, wiping off sea growth to clear a picture of weld or carrying a short ruler or a marked diving knife to give dimensions can be helpful to topside viewers.
    - (a) The diver's camera provides a small field of view. The view can be affected by water clarity, the diver's exhaust bubbles, the diver's motion and speed of advance, glare from the diver's light as well as the amount of available light, etc. The diver's comments on the overall condition of the hull regarding sea growth, damages, and the coating system may prove to be helpful, but the inspector should maintain control of the inspection by requiring the diver to proceed at a pace such that there is good visual acuity of the section of the hull being photographed. The inspector may also have to direct the diver to

## USCG Marine Safety Manual, Vol. II: Materiel Inspection

## SECTION B: DOMESTIC INSPECTION PROGRAMS

## CHAPTER 3: HULL EXAMINATIONS

adjust the attitude of the camera to reduce glare or to bring an item more into focus.

- (b) The measure of reliance upon such information is left to the judgment of the inspector at the time of the inspection and, ultimately, to the OCMI.
- (3) Monitor system. A color TV system should be used. A color bar or test slate should be available to allow proper adjustment of the picture for maximum efficiency and clarity. This includes consideration for a compatible lighting system (type of light, candlepower, etc.). The monitor presentation should be satisfactory to the inspector/OCMI. It should concentrate on hull appurtenances (propellers, rudders, bilge keels, sea chests, etc.) as well as any areas of damage. Although it may not be necessary to cover every inch of every weld on the underwater body, the attending inspector/OCMI should be satisfied as to their satisfactory condition.

**NOTE:** The owner should provide a copy of the audiovisual tape and the written report by the diving company to the OCMI.

- (4) Photography. Still photography generally provides better detail than TV images. This is particularly useful in specific or localized applications such as damage or deformation. Its use is highly recommended when questionable areas are found on a hull.
- (5) NDT procedures. These may consist of the diver's visual examination, magnetic particle inspection, or ultrasonic testing. Magnetic particle methods are available for crack detection or help in determining the extent of cracks. Ultrasonic testing is recommended for thickness gauging. In any case, operators should be appropriately qualified and qualifications should be verified. Equipment calibration is likewise necessary.
- l. Acceptable underwater repairs. Limited underwater repairs are possible, using newly developed techniques or materials. Some applications of welding, both wet and dry, are possible below the water's surface. Presently, any underwater weld should be considered a temporary repair, subject to reevaluation at subsequent inspections and haul outs.
- m. Evaluating results of the survey. The ship's operating schedule should not prevent the underwater survey from being conducted to the complete satisfaction of the inspector. If the OCMI is not completely satisfied with the results of the survey, credit should not be given for the survey.

**SECTION B: DOMESTIC INSPECTION PROGRAMS****CHAPTER 3: HULL EXAMINATIONS**

---

**D. TAILSHAFT EXAMINATIONS**

---

**1. Introduction**

Periodic examinations of tailshafts are conducted to determine--

- a. Evidence of undue wear on the liner or bearing;
  - b. Cracks in the shaft or liner; and
  - c. That the watertight integrity of the through-hull assembly (gland, bearing, and seals) remains satisfactory for continued service.
- 

**2. Inspection Standards and Applicability**

The regulations which generally apply to ocean and coastwise vessels are 46 CFR 61.20-15 through 23. These regulations reserve all extension authority for the Commandant. That extension authority is delegated to the district commanders for certain vessels per Subparagraph A.4.d(9) above.

- a. T-Boats. For these vessels, the only regulations require the inspector to examine the tailshaft and stern bearing to determine that they are in satisfactory condition.
- b. Great Lakes vessels. 46 CFR 61.20-23 applies only to vessels operating on ocean or coastwise routes. There are no comparable Coast Guard regulations for vessels operating on other routes.
  - (1) For these vessels, the standards in the ABS Rules for Building and Classing Steel Vessels may be used as a guide to determine the limits of wear down in the stern tube and strut bearings. The ABS Rules permit an additional 1/16" wear down for Great Lakes service when the shaft diameter is 12 inches or less, and an additional 1/8" wear down when the shaft diameter exceeds 12 inches.
  - (2) The ABS Rules may also be used in determining the limits of wear down for other vessels on inland routes, but they should not be applied as mandatory requirements for corrective action to be taken when these limits are exceeded or as authorization for wear down to reach these limits.

## USCG Marine Safety Manual, Vol. II: Materiel Inspection

**SECTION B: DOMESTIC INSPECTION PROGRAMS****CHAPTER 3: HULL EXAMINATIONS**

- (3) Requirements for corrective action on inland vessels must be determined by the OCMI, depending on the route, the diameter of the shaft, the type of bearing, and other safety factors involved.
- c. Propellers without tailshafts. Thrusters and similar propulsion units without "in-line" shafts are not normally subject to tailshaft examination requirements (see MODU requirements in D.11 below).
- 

**3. Examination Intervals**

46 CFR Part 61 requires propulsion tailshafts to be drawn for examination at different specified intervals based on various criteria, such as the number of separate propulsion shafts; materials of fabrication; whether or not the shaft is exposed to saltwater; type of bearing lubrication; whether or not the shaft has stress reduction properties, type of bearing material; and propeller-to-shaft connections.

Whether or not the shaft has been previously repaired should also be considered when determining if the examination interval should be reduced from that required in regulation.

---

**4. Examination Procedures**

When examining a tailshaft, the inspector must pay special attention to detecting fractures and wear in way of the taper, keyway, and liners. The stern bushing (after bearing) must also be carefully examined, and replaced or rebushed if necessary.

At every DE and underwater survey, the inspector must determine the amount of wear in the after tailshaft bearing. The inspector must require corrective action to be taken on all vessels when--

- a. The clearance exceeds the limits prescribed in 46 CFR 61.20-23 for ocean or coastwise vessels;
  - b. The condition of the bearing, shaft, or liner is determined to be unsatisfactory; or
  - c. The wear is otherwise considered excessive. For oil bearings, the manufacturer's instructions for periodic maintenance and examination should be followed.
-



**SECTION B: DOMESTIC INSPECTION PROGRAMS****CHAPTER 3: HULL EXAMINATIONS****5. Design Standards to Reduce Stress Concentrations**

- a. Generally speaking, there are several different factors recognized to reduce stress concentrations in tailshaft design. These include--
- (1) Spooning the forward area of the keyway;
  - (2) Slotting the forward end of the key;
  - (3) Locating the first keybolt well back from the forward end of the key;
  - (4) Providing an ample fillet at the bottom corners of the keyway;
  - (5) RADIUSING the corners at the top of the keyway;
  - (6) Providing a hoop stress groove for the liner; or
  - (7) Using a gradual rise from the bottom of the keyway to the surface of the shaft and ending several inches back from the propeller hub counterbore.
- b. Also, a keyless design strives to eliminate stress concentrations. Regardless of design, the forward one-third of the taper remains a critical area to be examined for fractures.
- 

**6. Tailshafts with Non-Continuous Liners**

To determine the interval at which a tailshaft must be drawn under 46 CFR 61.20-17, tailshafts that have a non-continuous liner may be considered as having continuous liners, provided the liner sections are joined as follows:

- a. The gap between the sections must be 1 inch or less; and
  - b. The connection between them must be made of vulcanized or synthetic rubber that is reinforced between layers.
- 

**7. Bearing Wear**

Wear readings give a general indication of any change in the clearance between the bearing and the shaft.

**SECTION B: DOMESTIC INSPECTION PROGRAMS****CHAPTER 3: HULL EXAMINATIONS**

For oil bath bearings, wear-down readings are compared with the original readings that were taken when the bearings were installed or renewed. For water lubricated bearings, the wear-down is either a measure of the total clearance between the bearings and the shaft (wood bearings), or the depth of the water groove (rubber bearings).

The methods used to take wear-down readings should duplicate those used for the original readings as much as possible. This includes the same measuring instrument and method, shaft location and loading, and even environmental conditions.

---

**8. Water Lubricated Bearings**

With wood or rubber bearings, feeler gauges of known thickness can be inserted between the shaft and the bearing to determine the amount of wear-down.

Wear-down may also be taken on wood bearings with a small wedge. The wedge is inserted between the shaft and then removed. The impressed clearance is measured with a micrometer to determine the wear-down.

See 46 CFR 61.20-23(a) for maximum wear-down readings for wood bearings.

Rubber bearings must be renewed when any water groove is found to be half its original depth.

---

**9. Oil Lubricated Bearings**

Experience has shown that oil bearing tailshafts rarely have problems unless they are disturbed. Drawing, shifting, or bumping the tailshaft requires the removal of bearing seals and increases the chance of scoring the tailshaft and bearings. Tailshafts with oil lubricated bearings need not be drawn for examination provided the provisions of 46 CFR 61.20-17(d) are met. Wear-down readings should be taken and compared to previous readings, and the results of the required semi-annual lubricating oil analysis should be reviewed.

---

**SECTION B: DOMESTIC INSPECTION PROGRAMS****CHAPTER 3: HULL EXAMINATIONS****10. Strut Bearings**

On vessels with separate strut bearing arrangements, both the after stern tube bearing and the strut bearing need to be evaluated.

- a. The after stern tube bearing should be evaluated for watertight integrity reasons. Wear-down readings are normally taken. This portion of the tailshaft is not required to be shifted aft.
- b. The strut bearing is of primary importance for evaluating the overall bearing wear and tailshaft condition. Although the tailshaft bearing wear-down requirements in 46 CFR 61.20-23 refer to the "after stern tube bearing," the intent is to evaluate wear-down at the aftermost bearing. The wear-down requirements therefore apply to the after strut bearing.
- c. Oil lubricated strut bearings may be examined without shifting the shaft aft under the equivalent inspection arrangement described in D.9 above.

---

**11. Tailshafts on MODUs**

MODUs are provided an alternative tailshaft inspection procedure in 46 CFR 61.20-17. To meet the requirements of 46 CFR 61.20-17, a MODU's tailshaft(s) should be examined during each underwater examination for credit. An examination procedure should be included in the special plan submitted by the vessel's owner in accordance with 46 CFR 107.265 or 107.267. During approval of special examination procedures, the OCMI may require any tests or examination requirements that are deemed necessary to ensure satisfactory condition of the tailshafts.

- a. To examine wooden or rubber bearings, a hole in the top of the rope guard and a suitable wedge or gauge should be provided for checking the clearance. For oil lubricated bearings, means of ensuring that the oil seal is intact and for checking the stern bearing clearance should be provided. Maintenance records and a statement from the chief engineer should also be used to evaluate the condition of the tailshaft(s).
  - b. Tailshafts, seals, and bearings on MODUs, regardless of the vessel's propulsion designation (self-propelled, propulsion assisted, non-self-propelled), may be more significant to the vessel's overall safety from a flooding hazard viewpoint than as a loss of propulsion. Inspectors should evaluate the flooding potential of shaft bearings and seals as is done with other through hull fittings.
-

**SECTION B: DOMESTIC INSPECTION PROGRAMS****CHAPTER 3: HULL EXAMINATIONS****12. Flanged Tailshafts with Propeller Coupling Bolts**

The NDT of propeller flange bolts that may be exposed to corrosive environments is particularly important. The testing procedure and the operator's qualifications should be approved by the inspector. For bolt designs that are totally enclosed in oil (e.g., a Ross Turnbull bearing design), the NDT requirement of 46 CFR 61.20-18 may be waived, provided both a visual examination and oil sample analysis are satisfactory.

---

**13. Oil Sampling**

The reliance on lubricating oil analysis to detect early seal failure or bearing wear emphasizes the importance of proper sampling techniques. Oil samples should be taken in accordance with the bearing manufacturer's recommendations or at a minimum of once every 6 months. The sample should be taken from a low point in the system to catch any water or metal filings in the system.

---

**14. Tailshaft Repairs**

MSM Volume II, Material Inspection, COMDTINST M16000.7A (series), Chapter A5 contains a discussion of welding repairs that is applicable to tailshafts.

---

---

**E. RUDDER ASSEMBLIES**

---

**1. Rudder Stocks on C3 Freighters**

Certain C3-type cargo vessels were fitted out with cast steel rudder stocks, with the stock cast integral with the upper palm. On some of these vessels, cracks have been detected just above the rudder stock palm, apparently due to the short fillet. In several cases, these cracks had progressed to the point where a complete fracture occurred. However, available information indicated that the incidence of fracture in these rudder stocks was not serious enough to warrant rejection of the design.

**SECTION B: DOMESTIC INSPECTION PROGRAMS****CHAPTER 3: HULL EXAMINATIONS**

During drydock inspections of this type of vessel, particular care must be taken to determine whether fillet cracks have started in the forward end of the upper rudder stock palm assembly. If so, corrective repairs or replacement must be required. Repairs can be made if the casting is of homogeneous structure. Unfortunately, this is generally not the case with wartime material. Replacement stocks should be of forged, rather than cast, material.

**2. Pintle, Rudder, and Rudder Post Defects****a. Vessels with semi-balanced rudders (without rudder posts).**

- (1) Case histories. Generally, these are T2-type tank vessels, although the examinations described here should be conducted on all vessels with similar rudder arrangements. One vessel's loss of this type of rudder is believed to have resulted from fracturing of the lower pintle in heavy weather. The entire rudder below the rudder stock palm, the lower pintle, the pintle, and the pintle nut were missing completely; the upper pintle was bent. Another vessel having such a rudder assembly lost the rudder; investigation revealed that the lower pintle had broken off completely, just below the securing point.
- (2) Inspection requirements. In view of such casualties, when a pintle is found loose or is withdrawn for any other reason, it should be examined by magnetic particle testing or another suitable method. It is particularly important to examine the pintle adjacent to the sleeve and between the threads and the small end of the taper.
  - (a) During the drydock examination, the condition of the pintle bushings, sleeves, nuts, and locking devices should be carefully examined. The discovery of a loose pintle would certainly justify its removal for further examination and verification of proper fit.
  - (b) Finally, the arrangements of the pintle locking devices should be such that the pintle cannot work free (on a third vessel, the pintle was found to have backed off, leaving the nut held in place only by a clip welded to the rudder framecasting). It is essential for the nut to be positively secured, to preclude "turning" of the pintle.

**b. Vessels with rudder posts.** Generally, these are C3-type cargo vessels, although the examinations described below should be conducted on all vessels with similar rudder arrangements.

- (1) Fractures have been found on some of these vessels in the rudder post castings just above or below the gudgeons; similar fractures have been found in the

## USCG Marine Safety Manual, Vol. II: Materiel Inspection

**SECTION B: DOMESTIC INSPECTION PROGRAMS****CHAPTER 3: HULL EXAMINATIONS**

rudder frame casting. In some cases, the fractures in the rudder frame and rudder posts extended from or into the core-hole closing plates on the after side of the rudder post.

- (2) During drydock examinations, the rudder frame and rudder post castings must be carefully examined at close range for possible fractures.
- (3) When conditions are suspect, the rudder post casting should be drilled about 6 inches above the welded joint to determine if water has entered the rudder post. If so, or if fractures are evident in the vicinity of the rudder frame gudgeons, a part of the rudder side plating should be removed for examination of the cast rudder frame arms, to which the horizontal diaphragms are attached. Particular attention must be directed to the casting at the midheight of the rudder.

---

**F. SEA CONNECTIONS**

---

**1. General Care**

It is essential that all sea connections and their attached fittings are carefully inspected while a vessel is drydocked or undergoing other inspection.

In one instance, a 3-inch nipple spool piece on the sanitary sea chest of a government vessel wasted away undetected. This led to a casualty that cost nearly \$1 million when the vessel's engineroom flooded.

It is imperative for all sea connections to be thoroughly examined and determined to be in good condition, even if drydocking is required to accomplish this. Particular attention must be directed to piping and fittings installed between sea valves and the sea.

---

**2. Condenser Water Boxes**

- a. Case histories. Investigation of one sinking determined that the outlet water box of the vessel's main condenser had ruptured. This resulted in a stream of water approximately 20 inches in diameter that flowed freely into the engineroom at approximately 20,000 gallons per minute.

- (1) The overboard and sea valves, 24-inch gate valves, each required two people to make 40-50 turns to close them. Attempts to close the valves failed because of the

**SECTION B: DOMESTIC INSPECTION PROGRAMS****CHAPTER 3: HULL EXAMINATIONS**

rapidity of the flooding. Approximately 5 minutes after the water box had ruptured, the engineroom was abandoned with the valves closed only partially.

- (2) The condenser water boxes had been opened and examined by ship's personnel only 6 weeks before this casualty; 8 months earlier, they had been painted over with apexior. The last inspection for certification had been made 16 months before the casualty. Neither crewmembers nor the inspector had noted any defects, and the condition of the water boxes was considered satisfactory at the time.
  - (3) Within a few months of this casualty, another vessel was inspected after complaints of a defective main condenser water box. The water box was found to be pinholed, and had 2 brass plate patches and a 20"x18"x16" cement patch. Both vessels were built in the 1940s; available records indicated that the water boxes had not been replaced since the vessels were put into service.
- b. Inspection requirements. Considering the age of such installations, it is essential for all condenser water boxes to be examined closely, at frequent intervals, both by ship's personnel and by Coast Guard inspectors.
- (1) At all inspections for certification, annual inspections, and periodic inspections of cargo and tank vessels, the inspector should examine condenser water boxes externally for patches, temporary repairs, and other obvious defects. In addition, the inspector should ask the ship's personnel about inspections they have made and the conditions observed.
  - (2) When conditions so warrant, the inspector must make internal examinations or tests to verify that the water boxes are in satisfactory condition, or to determine the extent of required repairs.

---

### **3. Nonmetallic Expansion Joints**

In one situation, a casualty to a rubber expansion joint in the main low-sea suction intake of a vessel resulted in flooding of the engine room and the near loss of the vessel.

The life expectancies of nonmetallic expansion joints depend upon their applications and the surrounding environments. For this reason, 46 CFR 61.15-12 requires the replacement of these expansion joints within 10 years after installation.

**SECTION B: DOMESTIC INSPECTION PROGRAMS****CHAPTER 3: HULL EXAMINATIONS**

A complete internal examination should be made of nonmetallic expansion joints whenever they are available for inspection and when external visual inspections reveal wear or other signs of deterioration or damage. If an adequate external or internal examination cannot be conducted by the inspector, the expansion joint should be removed for inspection.

The following are various problem areas associated with rubber expansion joints, their probable causes, and recommended repairs:

- a. Leaks at the flange. Retaining ring splits should be as close together as possible and flat steel washers should be used on the bolts over the splits. The bolts should be tightened uniformly by moving alternately around the flange from bolt to bolt until the rubber on the joint flange bulges slightly and uniformly between the steel retaining ring and the piping flange.
- b. Cracks at base of arch or flange. These are caused by unexpected pipe movements that put excessive stress on the joint, most commonly from initial misalignment at the time of installation, excessive pipe movement, improper anchorage, or failure to use control rods. If such cracks are severe enough to interfere with the integrity of the joint, it must be replaced after the cause of the damage has been corrected.
- c. Ballooned or otherwise deformed arches. These indicate interior displacement of reinforcing rings or wire, usually because of higher-than-recommended pressures. The joint must be replaced after all working conditions have been checked and proper recommendations made.
- d. Loose outer body fabric. A feeling of softness or looseness near the surface of the arch indicates a loss of adhesion between fabric plies. If plies have separated, the joint must be replaced.
- e. Spongy feeling of the joint body. This is caused by moisture penetration and deterioration of the fabric, usually from loose bolts or deterioration of, or physical damage to, the bolt hole sealant. Operating conditions should be checked and the joint replaced.
- f. Hardness and cracking of the cover. This is caused by exposure to extreme heat, chemical fumes, ozone, and other elements in service conditions. The joint should be replaced after the cause has been determined and corrected.
- g. Cuts and gouges in the cover. These are caused by careless handling or damage from tools. Repairs should be made after consultation with the manufacturer and notification of the OCMI.

---

**G. CREDIT FOR DRYDOCKING IN FOREIGN YARDS**



**SECTION B: DOMESTIC INSPECTION PROGRAMS****CHAPTER 3: HULL EXAMINATIONS**

Occasionally, vessel owners request credit for foreign drydockings that were not witnessed by Coast Guard inspectors. These requests are normally denied.

However, in certain unusual cases, the Commandant has authorized OCMIIs to grant extensions of time for making permanent repairs or credit for drawing of the tailshaft in a foreign yard. In the interest of safety, extensions are generally discouraged. Commandant (CG-CVC) will consider crediting foreign drydockings in unusual cases, upon a written request from the vessel owner or the owner's representative.

The request must include--

- a. Evidence that the drydocking was performed due to an emergency, not for routine repairs, cleaning, or inspection;
- b. Documentary evidence that the vessel's underwater hull and fittings were in a satisfactory condition at the completion of the drydocking. Normally, a certified copy of the drydocking report should be submitted by the foreign government's inspector or the classification society to indicate the conditions found and any repairs made; and
- c. Evidence that an inspection was requested, but an inspector was unavailable.

---

---

**H. RECORDS OF DRYDOCKINGS**

See MSM Volume II, Material Inspection, COMDTINST M16000.7A (series), Chapter A3 for information on the forms and means of recording hull examinations.

---

---

**I. CRITICAL AREA INSPECTION PLAN (CAIP) SURVEYS**

General hull examinations required as a part of a vessel's CAIP will be conducted as outlined in NVIC 15-91, NVIC 15-91, Change 1, and MSM Volume II, Material Inspection, COMDTINST M16000.7A (series), Chapters A5 and B4.

---

---

**SECTION B: DOMESTIC INSPECTION PROGRAMS****CHAPTER 3: HULL EXAMINATIONS****J. GUIDANCE IMPLEMENTING THE INTERNATIONAL CONVENTION ON THE CONTROL OF HARMFUL ANTI-FOULING SYSTEMS ON SHIPS FOR DOMESTIC VESSELS**

The International Convention on the Control of Harmful Anti-fouling Systems on Ships (AFS) Convention was adopted by the IMO to prohibit the use of harmful organotins in anti-fouling paints used on ships and to establish a mechanism to prevent the potential future use of other harmful substances in anti-fouling systems. Starting on November 21, 2012, U.S. flagged vessels, wherever located, and foreign flagged vessels in the internal waters of the United States, in any port, shipyard, offshore terminal, or other place in the United States, lightering in the territorial sea of the United States, or anchoring in the territorial sea of the United States, must comply with the applicable portions of the AFS Convention as outlined below. The type of anti-fouling systems controlled (prohibited) are specified in Annex 1 of the Convention. The Coast Guard implements the AFS Convention through the Coast Guard Authorization Act of 2010 (P.L. 111-281, October 15, 2010), (33 U.S.C. 3801 – 3857). Compliance verification for U.S. and foreign vessels shall follow the process and scope as described in the applicable portions of this manual.

The International Anti-fouling Systems (IAFS) Certificate and attached Record of Anti-fouling Systems (ROAFS), document compliance with the AFS Convention. U.S. flagged vessels 400 gross tons and above, as measured under the International Convention on Tonnage Measurement of Ships, 1969 (ITC), engaging on international voyages (excluding fixed or floating platforms, floating storage units, and floating production storage and off-loading units), must demonstrate compliance with the AFS Convention through possession of an IAFS Certificate (33 U.S.C. 3821). Those U.S. vessels not in compliance with the AFS Convention may be subject to foreign port state control actions when engaged on international voyages. Therefore, Sector Commanders/OCMIs should encourage proactive compliance with this section of the MSM to avoid detention of U.S. vessels in foreign ports. All vessels 24 meters or more in length, but less than 400 gross tons engaged in international voyages, except those specifically excluded by reference (a), shall carry a Declaration signed by the owner or owner's authorized agent (33 U.S.C. 3822). This Declaration shall be accompanied by appropriate documentation (such as a paint receipt or a contractor invoice) or contain an appropriate endorsement. This Declaration may also take the form of a Statement of Voluntary Compliance (SOVC). The format of a Declaration and a template form can be found in Appendix 2 to Annex 4 of the AFS Convention.

For applicable U.S. vessels, the Coast Guard or Recognized Classification Society (RCS) will verify compliance with the provisions of the AFS Convention and issue IAFS Certificates and attached ROAFS during routine scheduled inspections. As noted in above, vessels over 400 ITC engaged in a least one international voyage must carry an IAFS certificate (33 U.S.C. 3821). All inspected vessels to which the AFS Convention is applicable, but that do not require an IAFS Certificate due to size or tonnage, will receive an endorsement on their Certificate of Inspection (COI). The endorsement will read as follows: *"This vessel's anti-fouling system has been verified to meet the requirements of the International Convention on the Control of Harmful Anti-Fouling Systems"*. Verification of

**SECTION B: DOMESTIC INSPECTION PROGRAMS****CHAPTER 3: HULL EXAMINATIONS**

anti-fouling systems will normally be conducted during inspection for certification, annual re-inspection, dry-docking, or an annual survey conducted by the RCS. The Coast Guard or RCS may conduct AFS Convention compliance surveys and issue IAFS Certificates upon request at anytime if an international voyage is anticipated and the certificate is required prior to that voyage. The Coast Guard or RCS will conduct the following compliance exams for the issuance and endorsement of IAFS Certificates:

1. **Initial Survey:** Under the AFS Convention, Annex 4, Regulation 1, an initial survey must be carried out for a new construction vessel or for an existing vessel before the IAFS Certificate is issued for the first time. The OCMI or RCS will verify that the vessel's anti-fouling system fully complies with the requirements of the AFS Convention. After successfully completing the examination, the Coast Guard or RCS will issue the IAFS Certificate. The IAFS certificate ceases to be valid when the AFS is changed or replaced.
2. **Changes to the AFS:** A survey must be carried out whenever an anti-fouling system is changed or replaced. Such surveys should cover the same scope as an Initial Survey and a new AFS Certificate shall be issued. In accordance with Resolution MEPC.195(61), Guidelines for Survey and Certification of Anti-fouling Systems on Ships, a vessel undergoing a major conversion which affects the anti-fouling system may be required to undergo an initial survey as determined by the OCMI or RCS. Repairs affecting approximately twenty-five (25) percent or more of the anti-fouling system should be considered as a change or replacement of the anti-fouling system.
3. **Procedures for Conducting Surveys:** Article 10 of the AFS Convention requires vessels to be surveyed and certified in accordance with the regulations contained in Annex 4 of the AFS Convention. The types of anti-fouling systems controlled (prohibited) are specified in the table located in Annex 1 of the AFS Convention. The OCMI or RCS should use the procedures adopted by the Marine Environmental Protection Committee as outlined in Resolution MEPC.105(49), Guidelines for Inspection of Anti-Fouling Systems on Ships to conduct the required surveys. Only upon successful completion of the survey/examination will the IAFS Certificate be issued.
4. **Noncompliance with AFS Convention Requirements:** Operation of a vessel on international voyages without an IAFS Certificate may subject the vessel to detention by foreign port state officials. If the OCMI or RCS cannot determine if a vessel's anti-fouling system is in compliance with the AFS Convention, the OCMI or RCS shall withhold issuance of the IAFS Certificate until compliance is proven and restrict the vessel's route to domestic voyages only. Other enforcement actions by the Coast Guard may include Letters of Warning, Notice of Violations, or civil penalty actions as determined by the OCMI.

## USCG Marine Safety Manual, Vol. II: Materiel Inspection

**SECTION B: DOMESTIC INSPECTION PROGRAMS****CHAPTER 3: HULL EXAMINATIONS**

5. Obtaining an IAFS Certificate from the Coast Guard or RCS: Vessel owners and operators of U.S. flagged vessels should contact their cognizant OCMI or RCS for an inspection/survey and issuance of an IAFS Certificate and ROAFS. The IAFS Certificate and ROAFS issued by the Coast Guard are available under USCG Form numbers CG-6059 and CG-6059A, respectfully. Only RCSs that have been delegated the authority to issue IAFS Certificates on behalf of the Coast Guard in accordance with 46 CFR 8.320 may issue IAFS Certificates to U.S. flagged vessels (76 FR 76896, (December 9, 2011)). Prior to U.S. ratification of the AFS Convention, RCSs may have issued SOVCs to those vessels meeting AFS Convention requirements. Vessel owners and operators who currently possess a valid SOVC should now contact their RCS for issuance of an IAFS Certificate. Vessel owners and operators may request the Coast Guard issue an IAFS Certificate based on a SOVC provided there is sufficient proof that the anti-fouling system has not been changed or replaced since the SOVC was issued.
  
  6. Marine Information for Safety and Law Enforcement (MISLE): When the AFS inspection is conducted as part of a COI, annual, dry-dock, or other inspection activity, a notation shall be made within the activity's narrative. If the AFS inspection is conducted as a standalone inspection, it should be documented as an "Administrative Inspection" with the inspection details documented in the narrative. Once issued, a copy of the IAFS Certificate shall be scanned and attached into the vessel's list of documents.
-

**SECTION B: DOMESTIC INSPECTION PROGRAMS****CHAPTER 4: INSPECTION PROCEDURES APPLICABLE TO VESSEL TYPES, CLASSES, AND CATEGORIES****A. SMALL PASSENGER VESSELS ("T-BOATS")****1. INTRODUCTION**

The statutes relating to the inspection and certification of small passenger vessels are found in 46 U.S.C. 3301, et seq. The implementing regulations, in Title 46 CFR, require a realistic appraisal of the operational needs of this industry. Because there are many types of vessels and operations to consider, it is impractical to try to develop regulations that cover all situations. Under 46 CFR Subchapter T, Officers-in-Charge, Marine Inspection (OCMI) are authorized to accept alternates or equivalents and to grant departures from the regulations when circumstances so warrant. In the development of the T-boat regulations, the primary considerations were--

- a. Ignorance or misunderstanding of the hazards of the sea by most passengers;
- b. Overloading, fires, explosions, and marginal seaworthiness (these had caused several serious casualties on uninspected passenger-carrying vessels); and
- c. The need for a means of ready escape and survival in case of casualty.

**SPECIAL CONSIDERATION:**

Inspection personnel involved in the T-boat inspection program should never assume that vessel owners or operators are familiar with Coast Guard regulations and procedures. Inspection personnel must communicate with these owners and operators on a continuing, personal basis to explain requirements in detail. Experience has shown that after a vessel is inspected and requirements are explained, most of an owner's apprehension subsides and cooperation is enhanced.

Reports of inspection for certification and reinspection should note all items that have required interpretations of regulations by the OCMI, the district commander, or the Commandant. Such items include equivalents, substitutions, non-approved equipment, nonstandard fuel tanks, variations from subdivision standards, etc. These notes will form the basis for comparison of installed items with regulatory requirements at subsequent inspections.

## 2. Application

- a. Title 46 U.S.C. 3301(8) requires the inspection of small passenger vessels. Title 46 U.S.C. 2101(35) defines “small passenger vessels,” and 46 U.S.C. 2101(21) and (21a) define “passenger” and “passenger for hire.” These statutory definitions should be used in applying the inspection regulations.
  - b. There have been inquiries concerning application of the passenger vessel laws to vessels which are owned by a corporation, specifically in reference to the exemption in 46 U.S.C. 2101(25) and whether corporate owned vessels could ever be used only for pleasure. Each investigation into possible illegal passenger vessel operations must be evaluated based on the facts of that specific case. There are many corporate owned, documented vessels with pleasure as the only endorsement. Some of these vessels may be operating illegally by carrying passengers; however, most are undoubtedly legitimate, corporate-owned, pleasure vessels.
  - c. Corporate ownership alone does not prove that a vessel is a small passenger vessel. If business was not conducted during the voyage (i.e., carrying company employees as a morale incentive or bonus for performance) and no expectation of future business was anticipated (good will) from the voyage, the vessel should be considered as being operated for pleasure, and not as a small passenger vessel.
- 

## 3. Inspection Standards

- a. By statute, vessels less than 100 gross tons (GT) carrying more than 6 passengers must be inspected and certificated under 46 CFR Subchapter T, unless they are exempted from inspection by 46 CFR 175.100(b).
  - (1) Such vessels are referred to as “T-boats.”
  - (2) The regulations only apply to vessels carrying more than 6 passengers.
  - (3) Vessels carrying more than 150 passengers are subject to certain additional requirements contained in 46 CFR Subchapters F, H, J, K, and P, as determined by the OCMI. (Those vessels come under Subchapter K classification are called “K-boats”).
- b. Vessels carrying freight for hire. A T-boat may carry freight for hire, provided that--
  - (1) None of the cargo is prohibited from carriage on passenger vessels under 49 CFR Subchapter C (Hazardous Materials);
  - (2) Sufficient space is provided for the number of passengers carried;
  - (3) The vessel's stability is not endangered;

## SECTION B: DOMESTIC INSPECTION PROGRAMS

**CHAPTER 4: INSPECTION PROCEDURES APPLICABLE TO VESSEL TYPES, CLASSES, AND CATEGORIES**

- (4) The vessel is not overloaded;
  - (5) Passenger emergency escapes and access to emergency systems are not blocked; and
  - (6) Passengers are notified of the presence of any dangerous articles or of any other conditions or circumstances that would constitute an element of risk.
- c. Hazardous materials. All 46 CFR Subchapter T vessels are subject to the Hazardous Materials Transportation Act (HMTA) (U.S.C. 1801-1812) when carrying hazardous materials. For the purposes of 49 CFR, a vessel is a cargo vessel when it carries 16 or fewer passengers. When carrying more than 16 passengers, 46 CFR Subchapter T vessels are small passenger vessels.
- d. Foreign vessels. A vessel of a foreign nation party to the 1974 International Convention for the Safety of Life At Sea (SOLAS), and to the 1978 Protocol to the convention, that possesses a valid Passenger Ship Safety Certificate or Exemption Certificate must be examined at least annually.
- (1) If the vessel is in compliance with requirements of the SOLAS convention, it must be issued a Certificate of Compliance, Form CG-3585.
  - (2) A Canadian vessel possessing a valid Canadian Certificate of Inspection (COI) must be examined at least annually.
  - (3) If the vessel is in compliance with the terms of its COI, it must be issued a Certificate of Compliance, Form CG-3585.
  - (4) Foreign vessels that meet the applicability requirements of 46 CFR Subchapter T and do not possess SOLAS certificates must be inspected and certificated in the same manner as U.S. vessels.
- e. Vessels propelled by sail. A sail vessel, for purposes of 46 CFR Subchapter T, is a vessel that is propelled entirely by sail. A vessel with sails that also has means of steam, mechanical, or electrical propulsion must not be considered a sail vessel.
- f. Temporary COIs. A Temporary Certificate of Inspection, CG-854 must be used as on other inspected vessels. Pending receipt of new Temporary Certificate of Inspection, Forms CG-854, reference to "46 U.S.C. 399" in the first paragraph should be changed to "46 U.S.C. 3309(b)."
- g. Accepted classification society standards. The American Bureau of Shipping (ABS) and Lloyd's Register of Shipping are currently the only classification societies whose

standards of construction and equipment have been accepted by the Commandant relative to vessels inspected under 46 CFR Subchapter T.

- h. Life ring buoys. 46 CFR 160.050 previously required the marking of life ring buoys as follows: "For use on motorboats not carrying passengers for hire." These markings are no longer required; however, life ring buoys already manufactured must not be disapproved on the basis of such markings.
- i. Spare fuel for outboard motors. Under the authority of 46 CFR 147.45, the Commandant has certified the on-deck stowage of spare gasoline on T-boats. This applies to vessels that are propelled by outboard motors, as well as vessels carrying tenders, launches, etc., that are propelled by outboard motors. This certification is contingent upon the following conditions:
  - (1) The gasoline must be carried in steel containers with a capacity not exceeding 23 liters (6 gallons), constructed so as to have a built-in ullage space.
  - (2) Such containers must be of at least 20-gauge, welded steel construction built to withstand an internal pressure of 25 psi.
  - (3) Containers for holding gasoline must comply with the American Boat and Yacht Council, Inc. (ABYC) H-25 standard for portable fuel systems and portable containers for flammable liquids.
  - (4) To facilitate effective firefighting, containers for holding gasoline must be stowed in a rack on deck as far as possible from areas normally transited by passengers. Particularly, they must be stowed away from ventilation intakes and sources of ignition. The stowage arrangement must be approved by the OCMI.
  - (5) Fire extinguishing devices and their locations must be approved by the OCMI.
  - (6) A maximum of 10 gasoline containers may be stowed aboard the vessel at any time.
  - (7) "No Smoking" signs must be prominently displayed in the container stowage area.
  - (8) Empty containers must be handled and stowed with the same care as full containers.
  - (9) The vessel's COI must be endorsed to reflect the stowage of gasoline containers aboard.
  - (10) Final authority to authorize such carriage of gasoline rests with the OCMI. It should be granted only after the vessel's owner documents a bona fide need for the extra fuel and meets all the control conditions.



**SECTION B: DOMESTIC INSPECTION PROGRAMS****CHAPTER 4: INSPECTION PROCEDURES APPLICABLE TO VESSEL TYPES, CLASSES, AND CATEGORIES**

- j. **Radiator or air cooled engines.** Radiator or air cooled engines are prohibited by 46 CFR 182.420. This regulation was the result of a past ABYC standard to discourage the use of standard-type automobile engines, which had proven unreliable. The ABYC now permits air or radiator cooled engines provided that there is adequate ventilation for the engine. A departure from this regulation is authorized for well protected and ventilated engines, provided that a temperature alarm and remote indicator are installed. 46 CFR 182.420 will be revised to reflect this change in policy.
- k. For application of SOLAS 74, see Chapter E2 of this Manual.
- l. For information on Marine Sanitation Devices, see Chapter C2 of this Manual.

---

**4. Control of Unseaworthy Vessels**

An uncertificated T-boat may be sold to a party who wishes to carry more than six passengers without having it inspected and recertificated, whether in ignorance or intentional disregard of the inspection statutes and regulations. This could result in operation of an unseaworthy vessel that subjects its passengers and crew to potential hazards. Therefore, upon voluntary surrender or withdrawal of a T-boat's COI, the OCMI must notify the owner, in writing, of the following:

- a. The vessel may not carry more than six passengers unless it is inspected and certificated for passenger service.
- b. If the vessel is disposed of by sale, transfer, or other means, the former owner should inform the buyer of the obligation to obtain a valid COI before operating the vessel with more than six passengers. The former owner should notify the OCMI of the transaction within 48 hours, providing the name and address of the new owner.
- c. Continued operation or use of the vessel for any purpose in an unseaworthy condition may constitute negligent operations under 46 U.S.C. 2302, and may subject the owner to civil or criminal penalties.

**ACTION GUIDANCE:** Notification may take the form of the sample letter found in Figure B4-1. A copy of the notification must be placed in the vessel's file. If the vessel is documented, a copy must be forwarded to the vessel's port of documentation. OCMI's must maintain a monitoring program for all T-boats within their zones that are determined to be unseaworthy. Local Coast Guard and Coast Guard Auxiliary units should be advised of the names of such vessels. To assist inspectors and Auxiliary Courtesy Examiners, T-boats are required to display a Certification Expiration Date sticker in a readily visible location near the boarding

area (see A.7 of this Chapter).

USCG Marine Safety Manual, Vol. II: Materiel Inspection

## SECTION B: DOMESTIC INSPECTION PROGRAMS

**CHAPTER 4: INSPECTION PROCEDURES APPLICABLE TO VESSEL TYPES,  
CLASSES, AND CATEGORIES****FIGURE B4-1  
SAMPLE WRITTEN NOTICE TO THE OWNER OF A  
SMALL PASSENGER VESSEL**

[On OCMI's Official Letterhead]

[ADDRESS OF OWNER]

Dear Mr./Mrs./Ms./Sir:

I am writing to you in regard to the small passenger vessel (Vessel Name), Official Number (O.N.), for which our records indicate you are the owner. As you may know, the Coast Guard Certificate of Inspection for this vessel recently (expired/was suspended/revoked) on (Date) for the following reason(s): (Specify). For your own protection, this letter is to inform you of some of the less apparent aspects of small passenger vessel laws and regulations and to ensure that you are aware of certain requirements this situation presents for you.

First, the vessel may not be operated carrying more than six passengers until existing deficiencies are corrected and the vessel is inspected and re-certified for passenger service.

Second, if you should sell or transfer your vessel to a new owner, please inform the new owner of his or her obligation to obtain a valid Certificate of Inspection before employing the vessel in the carriage of more than six passengers. I ask that you also inform my Inspection Department, within 48 hours, of any change of ownership and provide the name and address of the new owner.

Finally, you should be aware that operating a vessel in an unseaworthy condition may constitute negligent use under Federal Law (Title 46, United States Code, Section 2302), and could subject you to civil or criminal penalties.

A copy of this letter has been placed in the vessel's file at this office (and a copy forwarded to the vessel's port of documentation). If you should have any questions, please do not hesitate to contact my Inspection Department at the telephone number listed above

Sincerely,

(Signature)

**(Title)**

## 5. Charters of Small Passenger Vessels

- a. Demise or bareboat charters. The following guidance should be helpful in determining whether a vessel under a demise, or bareboat, charter is subject to inspection. Often, information received third parties must be verified before such a decision may be made. An effort should be made to discuss each case with the vessel owner to learn the details of the owner's operation, inform the owner of the requirements of a valid bareboat charter, or clarify Coast Guard enforcement policy, if necessary. OCMI's must refer all cases that cannot be clearly determined initially to the district commander and defer action pending the district commander's determination.
- b. Background. The law that requires the inspection and certification of small commercial passenger-carrying vessels was enacted on May 10, 1956, by a Congress gravely concerned by several marine casualties involving loss of life on uninspected vessels that were carrying passengers for hire.
  - (1) Three of the most tragic of such incidents were the sinking of the motor vessels JACK and PELICAN off of Long Island, in separate incidents in 1951, and the loss of the sailing vessel LEVIN J. MARVEL in Chesapeake Bay in 1955. These casualties resulted in the combined loss of 70 lives.
  - (2) The legislative history of the Small Passenger Vessel Act of 1956 (now codified in 46 U.S.C.) reflects the will of a Congress determined to lessen the assumption of needless risks by private citizens who are carried aboard small passenger vessels.
- c. Demise charter concept. The concept of bareboat, or demise, chartering of vessels has developed in admiralty law as a legitimate means of transferring the rights of ownership of a vessel to a charterer for a period of time.
  - (1) At the time of the drafting of the Small Passenger Vessel Safety Act of May 10, 1956, demise charters were seldom used by private firms, in favor of other more convenient and less risky charter agreements, such as the time charter. Demise charters were most often used by the Federal government as a device for acquiring necessary merchant vessel tonnage in times of war and emergency. During World War II, the government took over and operated, directly and through general agency agreements, many privately owned ships. Rather than condemn and pay for such a ship, the government would frequently take the vessel on demise from the private owner.
  - (2) Most bareboat charters were made for a period of time that exceeded a single voyage. Considering the motivating factors behind the Act and the way in which bareboat charters were commonly used at the time of its drafting, it is doubtful that the Congress intended to create a specific exemption from inspection for

## SECTION B: DOMESTIC INSPECTION PROGRAMS

**CHAPTER 4: INSPECTION PROCEDURES APPLICABLE TO VESSEL TYPES, CLASSES, AND CATEGORIES**

private yachts being bareboat-chartered to carry large parties of passengers on pleasure cruises. This practice has, however, become fairly common in recent years, and has withstood most legal challenges when all of the requirements of a valid bareboat charter are complied with. Such a charter, although it may expose the charterer to considerably higher risk than the charterer would assume as a passenger aboard an inspected vessel, is a legitimate option the charterer may choose.

- d. Enforcement. The Coast Guard's enforcement role in this specific area is limited to ensuring that bareboat charters meet the bareboat requirements.
- (1) Some vessel owners are unaware or have been misinformed of the requirements for a valid bareboat charter. Many of these persons never ask the local Marine Safety Office (MSO) or Marine Inspection Office (MIO) what would be required to meet the small passenger vessel rules.
  - (2) Others attempt to create the appearance of a bareboat charter to avoid the perceived expenses and inconvenience of Coast Guard inspection when, in fact, the cost and inconvenience in many cases is considerably less than might be thought.
- e. Evaluations of charters. The decision as to whether or not a valid bareboat charter exists is not a subjective one.
- (1) The necessary conditions of bareboat charters have been fairly well standardized, with the most significant and difficult test being that of control. The owner must give up his or her vessel "pro hac vice" (for the occasion) as a complete demise, turning over the incidents of ownership to the charterer: this includes complete management, control, and operation.
  - (2) Some yacht owners are reluctant to give charterers such complete control. Nevertheless, failure to do so creates an invalid bareboat charter. Likewise, any payment of consideration by the guests of the charterer, either to the charterer or the owner, would result in the guests being considered passengers for the purpose of the inspection statutes.
  - (3) To determine accurately if a bareboat charter is valid, it is necessary to evaluate not just the terms of the agreement between the parties, but also the operation itself. In some cases, the vessel's operation may not be in accordance with the agreement. In other cases, the charter may be fully in accordance with the agreement, which is itself faulty. For this reason, the evaluation process sometimes requires boarding a vessel while underway so that investigating officers may obtain first-hand information.

f. Elements of valid bareboat charters. The following provisions are indicative of a valid bareboat charter. Note that a valid bareboat charter does not necessarily require that all of these elements be present. Each arrangement must be evaluated on its own standing, according to the following:

- (1) Although a master or crew may be furnished by the owner, full possession and control must be vested in the charterer (a provision requiring the charterer to be guided by the advice of the furnished master or crew, in regard to technical matters or navigation, is acceptable).
- (2) The master and crew are paid by the charterer.
- (3) All food, fuel, and stores are provided by the charterer.
- (4) All port charges and pilotage fees are paid by the charterer.
- (5) Insurance is obtained by the charterer, at least to the extent of covering liability not included in the owner's insurance. A greater indication of full control in the charterer is shown if all insurance is carried by the charterer (of course, the owner retains every right to protect his or her interest in the vessel).
- (6) The charterer may discharge, for cause, the master or any crewmember without referral to the owner.
- (7) The vessel is to be surveyed upon its delivery and return.

**NOTE:** Any provision that tends to show retention of possession and control (including basic navigation) by the owner or the owner's representative should be carefully examined to see if it contradicts the claim to have created a bareboat charter.

## SECTION B: DOMESTIC INSPECTION PROGRAMS

**CHAPTER 4: INSPECTION PROCEDURES APPLICABLE TO VESSEL TYPES,  
CLASSES, AND CATEGORIES****6. Cable Ferries**

On 25 July 1922, the Acting Solicitor of the Department of Commerce rendered an opinion regarding a vessel operated as a double-ended ferry. The vessel had two drums aboard for endless cable that was rigged onshore at each side of the river; the vessel was thus pulled back and forth by machinery. This vessel was determined to be "propelled by machinery" and thus subject to inspection under 46 U.S.C. Chapter 33.

---

**7. Railing Installations**

- a. Case history. The need for requirements for railing installations on T-boats was made clear to the Coast Guard by a particular casualty.
    - (1) The vessel involved was a 95-foot party fishing boat with 63 persons aboard. In a moderate sea, the vessel rolled to starboard and all passengers on that side of the vessel leaned or fell heavily upon the railing at the same time. The railing gave way and nine persons fell overboard. Fortunately, all were recovered and no injuries were sustained.
    - (2) The vessel had been inspected 7 months prior to the casualty. Subsequently (not as a requirement of the inspection), the owner replaced the aluminum railing sockets without the OCMI's knowledge or approval. The replacement sockets were not of a type accepted for marine use, and when installed and painted the material type was not readily discernible. The failure of these aluminum sockets was determined to be the primary cause of the casualty.
  - b. Inspection requirements. During inspection of a T-boat, the inspector must question the owner or the owner's representative as to any repairs that are anticipated or have been made.
    - (1) The requirement for such repairs or alterations to be made only with the OCMI's approval must be emphasized. All railings must be examined visually to identify defects or material problems and then given an appropriate test of their ability to withstand the cumulative load of persons who may rely upon it for support.
    - (2) Prior to the casualty cited above, moderate shaking of a railing installation had been regarded as sufficient, in the interest of avoiding costly, inspection-related repairs. However, this casualty demonstrated that railings may periodically be required to withstand a cumulative, instantaneous lateral force from a large number of people. Although a destructive test is not desired, the inspector must be satisfied that a similar casualty is not likely to occur.
-

## **8. Inspection of Shell Plate Butt Welds of Aluminum T-Boats**

In 1996, during routine drydocking examinations of several aluminum T-boats constructed in a southern Louisiana shipyard, circa 1990, inspectors discovered that the edges of the shell plate at the joints had received no edge preparation (i.e, square butts). This lack of proper edge preparation precludes any chance for consistent full penetration welds to be achieved. The particular builder has constructed over 400 aluminum boats since 1969, many of which remain in current service with no known history of structural failure due to the poor welding detail. It is further believed that this is not restricted to this single builder but is probably commonplace in aluminum boats constructed by other U.S. yards on the Gulf Coast.

Due to the method of fit-up, welding and lack of back gouging, a lack of fusion line exists within the weld and is not readily apparent from visual inspection. Existence of this lack of fusion was confirmed by x-rays of the shell welds.

Prior to these discoveries, the Coast Guard did not widely discourage this type of fit-up and welding, although it was not generally deemed to be good marine practice. While not considered acceptable from a technical standpoint, it has nonetheless proven its serviceability over time. However, a recent review of this detail by Commandant (CG-ENG) personnel suggested that while it may not cause immediate catastrophic structural failure of the hull, the long term effects of fatigue, to which aluminum is particularly susceptible, may affect the long-term durability of the hull to resist inherent fracturing while in service or from some mechanical impact damage.

As previously mentioned, there is no readily apparent failure history which warrants a complete reweld of the hull solely because it was constructed with lack of attention to good marine practice. To preclude future occurrence of this problem, specific policy for shell plate welding in new construction has been established in Chapter A5 of this Manual. When considering the risk to existing aluminum vessels, the short interval longitudinal and transverse stiffening required by NVIC 11-80, plus their proven in-service record, and excellent durability, obviate the need for immediate drastic repairs.

To standardize inspection procedures and to minimize the potential for future failures, the following actions must apply to all aluminum T-boats in service, especially those fabricated in Gulf Coast shipyards.

- a. All vessels must be subject to a mandatory, annual internal structural examination in conjunction with regularly scheduled inspections for the purpose of determining if butt and scam welds are being adversely affected by subsurface defects and discontinuities.



**SECTION B: DOMESTIC INSPECTION PROGRAMS****CHAPTER 4: INSPECTION PROCEDURES APPLICABLE TO VESSEL TYPES, CLASSES, AND CATEGORIES**

- b. Careful attention must be paid to the condition of the longitudinal and transverse structural members and their weld attachments to the shell plate. Any fractures to these welds must be documented and repaired immediately.
- c. The use of non-destructive testing, particularly X-rays, for the sole purpose of identifying lack of full penetration welds is discouraged.
- d. Any subsurface discontinuity which results in an in service structural failure, or has been exposed by mechanical damage, must be gouged to good metal and rewelded in accordance with the procedures set forth in the American Bureau of Shipping (ABS) Rules for Building Aluminum Vessels (1975), Chapter 30 Section 30.7 or Lloyd's Rules and Regulations for Classification of Yachts and Small Craft, Part 2, Chapter 3, dependent on the standard originally used to meet the structural design requirement of 46 CFR 177.300.
- e. Surface discontinuities, such as porosity stemming from new construction, should be accepted as they are, unless it is determined that it is being caused by electrolytic corrosion.
- f. A notation must be made in the MISLE data for each vessel to ensure that the annual examination requirement is followed. Additional MISLE entries must be made concerning the discovery of structural failures and their repairs.

---

**9. Public Awareness**

- a. The general public is typically unaware of the Coast Guard's requirements for small passenger vessels. It is for this reason that an aggressive public information program is considered necessary, particularly in zones in which a large number of this type of vessel operates. A primary means of conveying information to the public is publication of a marine safety newsletter. An information package that can either be mailed out in response to telephone inquiries or handed out during personal visits from the public is another convenient method of distributing information.
- b. Certification expiration date stickers. 46 CFR 176.01-45 requires T-boats to display certification expiration date stickers. This requirement is intended to increase public awareness of vessel inspection requirements and to encourage the public to favor T-boats that indicate that they meet those requirements. The inspector will provide stickers after the inspection for certification or at any time that the inspector determines them to be necessary to meet the intent of the regulations (the federal stock number for these is 7530-01-GF2-8620). The stickers are designed so that the expiration date of the COI can be punched in the date block at the bottom with a standard one-hole punch. Expired stickers and those on vessels whose COIs are

surrendered or revoked must be removed. OCMI's must provide hole punchers and scrapers to marine inspectors as needed.

---

---

## **B. EXCURSION VESSELS**

---

### **1. Definition**

An excursion vessel, as referred to in 46 CFR 2.01-45, 72.40-5 (c), and 46 CFR 176.204, is a passenger vessel that engages in short cruises for special events or recreational purposes. The operation of an excursion vessel is chiefly seasonal and normally involves the carriage of deck passengers.

---

### **2. Permit to Carry Excursion Party, CG-949**

When such operation is not permitted under the vessel's normal COI, Permit to Carry Excursion Party, CG-949 may be issued under 46 CFR 71.10 or 46 CFR 176.204, as applicable. This is the case when a passenger vessel is permitted to carry additional passengers or to operate on an extended route, or when a cargo or miscellaneous vessel is permitted to carry recreation parties on a 1-day basis. The permit must be issued for a limited time, and must be considered a temporary supplement to the COI only. An excursion permit must not be used to circumvent inspection requirements.

---

### **3. Conditions of Permits**

The OCMI must determine the maximum number of additional passengers that may be carried, the number and type of lifesaving appliances that must be provided, and the limitations of route, etc., for a vessel to engage in an excursion as provided in 46 U.S.C. 2113. Inspection of the vessel prior to issuance of Permit to Carry Excursion Party, Form CG-949 must be equivalent to reinspection of a passenger vessel. At this inspection, the inspector must pay particular attention to lifesaving and firefighting appliances. The applicable minimum stability and fire safety standards must not be waived or relaxed in any case.

**SECTION B: DOMESTIC INSPECTION PROGRAMS****CHAPTER 4: INSPECTION PROCEDURES APPLICABLE TO VESSEL TYPES, CLASSES, AND CATEGORIES****4. Passenger Capacity**

The number of passengers normally permitted on excursion vessels must be in accordance with 46 CFR 176.204. Other than stability and subdivision criteria, vessels inspected under 46 CFR Subchapter H (Passenger Vessels) have no specific limitations on the number of passengers permitted. To ensure a degree of uniformity in the application of the regulations, the criterion of one passenger for every 10 square feet of deck space must be used as a guide in determining the number of passengers permitted. Vessels that do not comply with structural fire protection requirements of 46 CFR 177.410 must not carry more than 150 passengers.

---

**5. Operational Limits**

The number of passengers and the route permitted for a vessel engaging on a temporary excursion must be limited to an operation that the OCMI believes can be safely undertaken. Careful consideration of possible downflooding (interior flooding of a vessel from the decks or over the gunwale) must be given in permitting an excursion route different from that which appears on the COI. Likewise, stability of the vessel must always be considered.

---

---

**C. CARGO VESSELS**

---

**1. Carriage of Passengers (Persons in Addition to the Crew)**

- a. Requirements for notice to passengers. Under 46 U.S.C. 3304, the owner, charterer, managing operator, agent, master, or individual in charge of a cargo vessel must notify all passengers of the presence aboard of any dangerous articles, or of any other condition or circumstance that would constitute a risk of safety for the passengers or crew.
  - (1) This notification must be issued before the vessel sails. All persons other than members of the crew and military personnel carried (either under waiver or otherwise) must receive this notice.
  - (2) Failure to give such notice renders the owner, charterer, managing operator, agent, master, or individual in charge subject to a civil penalty of not more than \$1,000, for which the vessel is liable in rem (see 46 U.S.C. 3318(h)).

- b. Operation upon examination. A cargo or tank vessel must be examined to ensure that it complies with the laws and regulations relative to lifeboats, life preservers, and other lifesaving equipment before it may carry persons in addition to the crew. After a satisfactory examination, authority to carry up to 16 persons in addition to the crew on domestic voyages, and up to 12 persons in addition to the crew on international voyages, may be granted by issuing a COI amendment or by a special endorsement on the COI.
- 

## **2. Subdivision**

The 1966 Load Line Convention allows deeper drafts for those cargo vessels (other than tankers) that qualify as one or two compartment subdivision vessels. The determination and assignment of a load line is a function delegated to ABS. Therefore, when a deeper draft is allowed due to subdivision consideration, inspections for certification and reinspections must be conducted with the object of proper maintenance of bulkheads, closures, etc., essential to the preservation of the applicable subdivision criteria. For more information, see MSM Volume IV, Technical, COMDTINST M16000.9 (Series).

---

## **3. Equivalentents Filed with the International Maritime Organization (IMO)**

See Chapter E2 of this Manual.

---

## **4. Carriage of Combustible Liquids in Bulk Aboard Vessels**

- a. Vessels certificated as passenger, cargo, or miscellaneous vessels may carry limited quantities of flammable or combustible liquid cargo in bulk in accordance with 46 CFR 30.10-5, 70.05-30, and 90.05-35.
  - (1) These "limited quantities" must not exceed 20 percent of the vessel's deadweight tonnage, as applied to bulk liquid cargo or that carried in integral or independent tanks.
  - (2) The carriage of such cargo must not be the principal purpose or use of such vessels.
  - (3) The OCMI must determine, on a case by case basis, that the vessel's principal purpose is not the carriage of liquid bulk cargo.
- b. Carriage aboard barges. Cargo barges certificated under 46 CFR Subchapter I may not carry flammable or combustible bulk liquid cargoes in any quantity.
  - (1) Barges carrying such cargoes must be considered tank barges and must meet the requirements of 46 CFR Subchapter D.

## SECTION B: DOMESTIC INSPECTION PROGRAMS

**CHAPTER 4: INSPECTION PROCEDURES APPLICABLE TO VESSEL TYPES, CLASSES, AND CATEGORIES**

- (2) 46 CFR Subchapter I barges may carry fuel for the use of their machinery and, when there is a need for additional fuel on occasional long voyages, fuel for the propelling vessel.
- (a) This may be done only when a genuine need for the fuel exists and there is no attempt to circumvent the applicable admeasurement or safety regulations.
  - (b) 46 CFR Subchapter I barges should only carry fuel for their machinery for occasional long voyages. If additional fuel is needed on a regular route, a propelling vessel with sufficient fuel capacity of its own should be employed.
- c. Discharge containment. When carrying oil, 46 CFR Subchapter I vessels with a capacity of 250 or more barrels must be in accordance with the cargo oil discharge containment requirements of 33 CFR 155.310. The requirements of 33 CFR Part 156 apply during transfer operations aboard such vessels, but 33 CFR Part 157 does not apply to vessels certificated solely under 46 CFR Subchapter I.
- d. Carriage of unusable, bunker or oil residue on vessels permanently laid-up, dismantled, or out-of-commission. Bunker oil and bunker oil residue existing in such vessels (i.e., on board at the time the vessel was permanently laid up, dismantled, or placed out of commission and remaining on board) is not classed as cargo. The condition of the tanks must be acceptable to the OCMI. Additional oil or oil residue cannot be added to any bunker, cargo or independent tanks on a vessel permanently laid up, dismantled, or out of commission. For more details, see Chapter B1 of this Manual.
- e. Carriage of fuel for the towing vessel on vessels permanently laid-up, dismantled, or out-of-commission. The carriage of fuel for the towing vessel on non-certificated vessels permanently laid up, dismantled, or out of commission being towed to scrap is not allowed. A vessel that carries fuel for the towing vessel would need to be inspected and certificated as a tank vessel and be issued the appropriate domestic and international certificates.
-

## **D. TANK VESSELS**

---

### **1. Permanently Moored Tank Craft**

A former tank vessel that is permanently moored at a fixed location to dispense, receive, or store flammable or combustible liquids in bulk may, at the request of the owner, be considered "substantially a land structure" subject to the waterfront facility regulations (33 CFR Parts 126, 154, and 156). To qualify under this terminology, the vessel must be securely and substantially such that it does not have a practical use for transportation on the water. As these craft are frequently unattended, such mooring arrangements must be acceptable to the COTP posing no risk to the port, waterway and environment, and must be capable of withstanding wind, ice, and water conditions encountered at the location. Special consideration must also be given to extreme weather that may occur including but not limited to hurricane force winds, flooding, or high water as appropriate. To mitigate risk in some cases, it may be appropriate for COTP's to require an operator to have mooring arrangements reviewed by a Professional Engineer (PE). These craft may also be subject to USACE permitting and EPA secondary containment requirements. See Paragraph I of this Chapter "Craft Routinely Operated Dockside" for additional guidance.

### **2. Tankships Carrying Grain Cargo**

- a. When a tankship is modified to carry grain in bulk, sounding pipes are fitted to each tank, the cargo stripping suctions are fitted with burlap-covered roseboxes and made to serve as bilge suctions, a nonreturn valve is installed at the stripping pump suction, the main cargo suctions are blanked off and cement-sealed burlap is installed at each bell mouth, the main cargo header in the pumproom is blanked off, and all cargo valves are closed and locked.
- b. Study of the modifications needed for a tank vessel to carry grain in bulk in its cargo tanks indicates that, ordinarily, none of the essential features of a tankship are lost in the transformation. Returning the vessel to tanker service requires removal of blanks from the main cargo suctions and manifolds, removal of burlap and cement seals in the cargo tanks after discharge of the grain cargo, and cleaning out of the remnants.
- c. Requirements for OCMI's evaluation. Upon inspection of a tank vessel that has been modified to carry grain in bulk, the OCMI must determine if the essential features that make the vessel eligible to carry flammable or combustible liquid cargo in bulk have been removed. If not, the COI need not be amended unless this is requested by the owner.

---

### **3. Tank Barges Not Carrying Flammable or Combustible Liquids**

A barge that has been certificated to transport flammable or combustible Grade D and E liquids may retain its unexpired COI aboard when transporting nonflammable or

**SECTION B: DOMESTIC INSPECTION PROGRAMS****CHAPTER 4: INSPECTION PROCEDURES APPLICABLE TO VESSEL TYPES, CLASSES, AND CATEGORIES**

noncombustible liquid cargoes. Such a barge must comply with 46 CFR Subchapter D requirements at all times.

**NOTE:** Any changes to the vessel's equipment or construction required by the regulations for transporting other cargoes would automatically make the COI subject to withdrawal.

---

**4. Metal Hoods and Housings**

46 CFR 32.35-5 requires a metal hood or housing over pump engines on tank barges, to protect the pump engines against weather and damage during cargo or hose handling. Installations for which metal hoods or housings are unnecessary to provide the desired protection may be accepted provided the arrangement affords equivalent protection. Each tank barge pump engine installation should be evaluated on its own merits to determine whether installation of a metal hood or housing is necessary.

---

**5. Refinery Waste, Dirty Ballast, Etc.**

Barges used for the transportation of refinery waste, residual cargo, or dirty ballast from tank cleaning operations are subject to inspection and certification when they carry flammable or combustible liquids in bulk. The application of 46 U.S.C. 3710 et seq., to vessels other than public vessels is not contingent on the vessel's use in trade or commercial service, as long as the liquid is cargo or residue.

**NOTE:** When such barges are used to handle flammable or combustible liquids, even if diluted with water, fire and explosion hazards are present and the applicable safeguards contained in 46 CFR Subchapter D must be met.

---

**6. Location of Flame Arresters**

46 CFR 32.55-20(b)(4) states that "The vent header shall be fitted with a flame arrester or pressure-vacuum relief valve." This regulation applies to the venting of tanks transporting Grade A liquid on tankships constructed on or after 1 July 1951. This regulation does not require either the flame arrester or the pressure-vacuum relief valve to be installed at the outlet. Some vessels have a pressure-vacuum relief valve installed in the horizontal deck header, rather than installing this type of valve or a flame arrester at or near the outlet; the Commandant has accepted this arrangement. The required installation of a pressure-vacuum relief valve in the header is in addition to the pressure-vacuum relief valve in the individual branch vent line, which is not mandatory (see 46 CFR 32.55-20(b)(3)).

---

## 7. Carriage of Passengers

The provisions of C.1 above apply to tank vessels as well as to cargo vessels.

---

## 8. Unmanned Tank Barge Inspections and Examinations

- a. Under 46 U.S.C. 3710, vessels that carry oil or any hazardous materials in bulk as cargo or in residue must be inspected or examined at least once annually. To satisfy these requirements, the Commandant's policy for the inspection of unmanned tank barges is that these vessels must have--
  - (1) Biennial inspections for certification; and
  - (2) Annual examinations occurring between the 10th and 14th month after the issue date of the COI.
- b. The biennial inspections for certification must be conducted by qualified marine inspectors.
- c. For unmanned tank barges that are certificated for the carriage of bulk dangerous cargoes under 46 CFR Part 151, annual examinations (formerly called "midperiods") must be conducted by qualified marine inspectors.
- d. For unmanned petroleum tank barges not certificated for the carriage of bulk dangerous cargoes, annual examinations may be conducted by qualified marine inspectors or port safety boarding teams provided they are qualified to conduct these examinations.
- c. Port safety boarding team guidelines. Port safety boarding teams will, in the course of routine monitoring or boardings, observe most of the items that should be inspected for an annual examination. In conducting an annual examination, a boarding team must include on its checklist of items to be examined--
  - (1) An examination of all firefighting and safety equipment on the vessel; and
  - (2) A visual inspection of accessible parts of the vessel. Particular attention must be paid to any obvious signs of damage, deterioration, or temporary repairs to the cargo piping, visible hull, flame screens, etc.
- d. When a routine monitoring/boarding of an unmanned petroleum tank barge is scheduled between the 10th and 14th month after the COI is issued, the annual examination may also be conducted by the port safety boarding team.



**SECTION B: DOMESTIC INSPECTION PROGRAMS****CHAPTER 4: INSPECTION PROCEDURES APPLICABLE TO VESSEL TYPES, CLASSES, AND CATEGORIES**

- (1) If no discrepancies are found, the boarding team should date and sign the COI. If discrepancies are discovered, they should be rectified per local OCMI guidelines.
  - (2) An entry should be made into MISLE noting the completion of the vessel's reinspection.
  - (3) See also COMDTINST 5010.8.
- e. Local procedures. Commanding Officers (COs) of MSOs should establish local procedures as to when a port safety boarding team will be authorized to conduct an annual examination and endorse the COI on unmanned petroleum tank barges. Local monitoring/boarding checklists should also be modified or established as necessary.

---

**9. Pressure Vessel Type Cargo Tanks**

A review of the records of several tank barges over 20 years old that were certificated to carry liquefied gas in pressure vessel type cargo tanks has indicated that their tanks were never hydrostatically tested. Under 46 CFR 38.25-1(b), a hydrostatic test of such tanks may be conducted at any time that an inspector considers it necessary to determine their condition. When a tank barge 20 or more years old becomes due for internal examination, the cargo tanks should be very carefully examined and a hydrostatic test should be considered.

---

**10. Trans-Alaska Pipeline Service (TAPS) Tankships**

- a. Background. The "Report of the TAPS Tanker Structural Failure Study" was published on 25 June 1990. The "TAPS Tanker Structural Failure Study Follow-up Report" was published in May 1991. Both reports addressed the reasons why TAPS tankers experienced a high number of structural failures compared to vessels in other trades.
  - (1) In order to combat these failures effectively, the principal recommendation of the TAPS study concerned the establishment of Critical Areas Inspection Plans (CAIPS) for all TAPS tankers. Specific guidance for CAIPs is contained in NVIC 15-91, NVIC 15-91, Change 1.
  - (2) Between June 1990 and June 1996, the Coast Guard, in partnership with TAPS operators and the ABS, conducted hundreds of CAIP examinations of TAPS vessels. While all TAPS vessels were subject to an annual examination of at least some portion of the cargo block, 16 vessels, 14 of which were in three distinct classes, were subject to more frequent examinations due to severe structural problems.

- (3) These structural problems were a result of a number of factors, including, but not limited, to poor design details, poor construction practices, lack of adequate internal coatings systems, lack of maintenance, age, and harsh environmental conditions that stressed hulls and were exacerbated by various operating practices employed prior to the studies.
- (4) As of June 1996, only six of these targeted vessels in the ATIGUN PASS 165,000 Deadweight Ton (DWT) class remain in existence. Only two of these vessels are currently in service. However, both operators of these vessels, BP America and SeaRiver Maritime, have been very effective in improving original design and construction details to the extent that the special six month interval between CAIPs originally imposed on these vessels is removed and the vessels may be examined under the 1-year CAIP interval provided for by NVIC 15-91. The vessels in this class are:
  - (a) S.S. ATIGUN PASS.
  - (b) S.S. THOMPSON PASS.
  - (c) S.S. BROOKS RANGE.
  - (d) S.S. KEYSTONE CANYON (downsized to 125,000 dwt in 1990).
  - (e) S.S. S-R BENICIA.
  - (f) S.S. S-R NORTH SLOPE.

b. Definitions.

- (1) TAPS Tanker A means a vessel that transports oil in bulk from Valdez, Alaska to any U.S. or foreign port.
- (2) Alaska North Slope (ANS) service is a U.S. Department of Commerce term for tankers carrying oil in bulk from Valdez, Alaska, to foreign ports. This definition is interchangeable with TAPS.
- (3) Cargo block, as applicable to tankers and OBOS, means all cargo and ballast tanks between the forward most and after most transverse cargo bulkheads.

c. CAIP requirements for TAPS tankers. Commandant (CG-CVC) will maintain a MSIS VFSC for CAIP status of TAPS tankers. TAPS tankers must comply with CAIP requirements, as follows:

- (1) Tankers new to TAPS service. All tankers initially entering the TAPS trade will be required to establish a CAIP for the full cargo block, per NVIC 15-91.

## SECTION B: DOMESTIC INSPECTION PROGRAMS

**CHAPTER 4: INSPECTION PROCEDURES APPLICABLE TO VESSEL TYPES, CLASSES, AND CATEGORIES**

- (a) Operators may apply to Commandant (CG-CVC) for alternative compliance with CAIP requirements, per NVIC 15-91, Change 1, 5.b.(2)(d) - (f), but will be subject to a baseline examination by the Traveling Inspectors (CG-5P-TI) prior to Commandant (CG-CVC) approval.
  - (b) The CAIP interval must be no longer than one year until a structural history can be developed by the Coast Guard. CAIPs may be performed within the 10th or 14th month following the previous CAIP survey.
- (2) Existing TAPS Tankers. Tankers that have been in continuous TAPS service are normally subject to annual CAIPs.
- (a) However, operators may apply to Commandant (CG-CVC) for relief of certain CAIP requirements on a case by case basis, as outlined in NVIC 15-91, Change 1. This includes elimination of certain portions of the cargo block from a CAIP examination or extending CAIP intervals.
  - (b) Approval of these requests will be based primarily on review of the structural failure history which may show the lack of significant problems over time or past structural problems which have permanently been corrected.
- (3) Tankers in and out of TAPS service. Circumstances may cause TAPS tanker operators to place vessels on other routes for extended periods of time. It is not mandatory to maintain the CAIP during such time periods. However, the vessel must complete a CAIP prior to return to TAPS service if the prescribed interval since the last CAIP has been exceeded.
- (4) CAIPs vs. ABS Enhanced Survey Guidelines. NVIC 15-91, Change 1 permits TAPS operators to substitute ABS Enhanced Survey guidelines for CAIPs on a case by case basis.
- (a) It has been determined that the Enhanced Survey 3 is equivalent to the CAIP requirements for those vessels that are approved for a normal two-in-5-year internal examination interval, which would correspond to the ABS Special Survey and Intermediate Survey requirements. However, the ABS Enhanced Survey requirements are not equivalent with a CAIP in scope and depth of annual examinations.
  - (b) Operators must affirm in writing to Commandant (CG-CVC) that the ABS Enhanced Survey requirements normally complied with at ABS Special Survey will be performed to satisfy annual CAIP requirements.
- (5) TAPS tankers involved in export trade. In April 1996, the President signed an authorization allowing export of Alaskan oil to foreign markets.

- (a) The authorization requires that exporters obtain a special permit from the Department of Commerce to engage in this trade. As a condition of obtaining the permit, the exporter must employ a tanker that is subject to an annual CAIP survey.
- (b) Consequently, although NVIC 15-91, Change 1 provides a provision for operators to extend CAIP intervals, a separate rulemaking by the Department of Commerce will require those vessels employed in oil export service to undergo a mandatory annual CAIP.
- (6) TAPS tankers enrolled in the Alternative Compliance Program (ACP). Tankers enrolled in the ACP may substitute ABS Enhanced Survey Guidelines for the CAIP examine provided that surveys are performed to the same extent required by the CAIP. For information about the ACP, see Chapter A5 of this Manual.
- (7) Reports of structural failure. TAPS operators must report Class 1 and 2 structural failures in accordance with the procedures outlined in Chapter A5 of this Manual. Acceptance of Enhanced Survey requirements in lieu of CAIPs or enrollment of a vessel in ACP does not relieve an operator of reporting responsibility to the cognizant OCMI.
- (8) Maintenance of records. A complete, up to date CAIP is required on each TAPS tanker and in the operator's office.
  - (a) A copy of the detailed survey report normally completed to append the vessel's CAIP must be provided to the cognizant OCMI where the survey is performed or where repair work, if required, will be conducted.
  - (b) An executive summary highlighting the CAIP must be provided to Commandant (CG-CVC) or review and forwarding to the Traveling Inspectors for maintenance in the TAPS file. The executive summary should contain the same, but less detailed information, required by enclosure (4) of NVIC 15-91. It is expected that the CAIP update and the executive summary be completed and placed aboard the vessel and forwarded, respectively, within 60 days of the CAIP.
  - (c) The cognizant OCMI must ensure the vessel's MISLE files are updated to reflect the current CAIP.
- d. TAPS repair guidance. The hierarchy of repairs described in this section is a guideline for repairs whether the fracture is found at the CAIP survey during routine operations.
  - (1) Class 1 structural failures. All such failures must be repaired prior to the vessel being permitted to return to service, in accordance with Chapter A5 of this

## SECTION B: DOMESTIC INSPECTION PROGRAMS

**CHAPTER 4: INSPECTION PROCEDURES APPLICABLE TO VESSEL TYPES, CLASSES, AND CATEGORIES**

Manual. Operators are always required to submit a Report of Marine Accident, Injury or Death, CG-2692 whenever a Class 1 failure occurs or is found.

- (2) Class 2 structural failures. These failures must be evaluated by the operator in concert with the cognizant OCMI and vessel's class society. Temporary repairs may be authorized. In some cases, if the failure has arrested itself or poses no further chance of propagation, the OCMI may authorize monitoring of the fracture with no repair until the next scheduled repair period. No CO-2692 "Ls required to be filed.
- (3) Class 3 structural failures. Repair of Class 3 failures may be held in abeyance to the next regularly scheduled repair period at the discretion of the operator. Repair of a Class 3 failure may be deferred and monitored if the OCMI determines that the repair would actually create a bigger problem such as expanding the heat effected zone between the weldment and base metal and causing additional stresses to be concentrated into a design detail.
- (4) The primary goal of the CAIP guidelines is to prevent reoccurrence of structural failures and not simply just to address the end result of the root cause of the problem. In order to ensure consistency between zones, it is imperative that OCMI's consider all past approved repair procedures which have been effective in service. It also is important that the root cause of any structural failure be determined or understood prior to approving a repair as either temporary or permanent."
  - (a) Temporary vs. permanent repairs. The terms "temporary" and "permanent" can have multiple meanings.
    - [1] For Class 1 structural failures, temporary repairs means emergency measures taken to allow a vessel to safely transit to a port or facility in order to effectively evaluate the failure and accomplish permanent repairs. A vessel must not be allowed to continue in service under the terms and conditions of its COI with only these temporary repairs, beyond the singular voyage to a discharge port or repair facility.
    - [2] For Class 2 and 3 structural repairs, temporary repairs means measures taken to prevent a structural failure from developing into a failure of the next highest class. Generally, such temporary measures are only intended to suffice until the next regularly scheduled repair period when permanent repairs can be effected. However, past history has shown that in many cases, these temporary measures have satisfactorily arrested the cause of the failures. At the request of the operator, the OCMI should evaluate the temporary repairs' effectiveness and may accept them as permanent, if warranted. In such cases, a Vessel/Facility Inspection Requierments, CG-

835 noting the temporary repair and requiring a subsequent permanent repair may simply be written off as completed, accordingly.

- (b) For all three classes of failure, permanent repairs should not necessarily be construed as repairs in kind. Structural failures resulting from a poor design detail will recur if that detail is restored as original. Much of the success realized to date in curtailing numbers of TAPS structural failures has resulted from improving design details. However, unless it is ascertained that a certain repetitive type fracture could reach critical proportions, it is acceptable to permit repair by traditional means such as veeing and welding. It should be recognized that structural repairs could be an iterative process, that is, that several permanent repairs may be proposed and accepted before a modification is successful in preventing recurring fractures.
- (5) Repair guidance. Guidance on previously approved repairs can be obtained from numerous sources, including, but not limited to the following:

## SECTION B: DOMESTIC INSPECTION PROGRAMS

**CHAPTER 4: INSPECTION PROCEDURES APPLICABLE TO VESSEL TYPES, CLASSES, AND CATEGORIES**

- (a) The vessel's CAIP;
- (b) Traveling Inspectors (CG-5P-TI) files;
- (c) Classification society files; or
- (d) The "Guidance Manual for the Inspection and Condition Assessment of Tanker Structures" published by the international Chamber of Shipping.

---

**E. SEAGOING BARGES**

---

**1. Introduction**

46 U.S.C.3302(m) provides that a seagoing barge is not subject to inspection if the vessel is unmanned and does not carry-

- (1) a hazardous material as cargo; or
- (2) a flammable or combustible liquid, including oil, in bulk

In this case, "in bulk" means a capacity of 250 barrels or more. Additionally, "hazardous material" as cargo includes flammable/combustible liquids or substances (see 46 USC 2101(14)).

Any barges that transit beyond the Boundary Line and are either 79 feet or longer (if built on/after 1 Jan 1988), or 150 GT or more (if built before that date) must have a valid Load Line Certificate (refer to 46 CFR Part 7 for delineation of the Boundary Line). A certificated barge is subject to inspection requirements until the COI is surrendered or expired, even though it may be operated for part of the time in inland waters.

---

**2. General Inspection Provisions**

- a. Operation on the high seas. Only those vessels which are manned or carry hazardous materials, as noted in 1, above, are required to be inspected and certificated.
- b. Plan approval. Complete plan approval is required for all vessels contracted for on and after 1 January 1964; plans must be submitted in accordance with 46 CFR 91.55.
- c. Acceptance of alternate arrangements. The basic inspection requirements for these vessels are contained in 46 CFR Subchapter I. It is the Commandant's policy that the OCMI construe the intent of the regulations liberally, while ensuring that the vessel can be navigated safely. Any unusual condition or feature of the vessel that is

accepted by the OCMI at the initial or subsequent inspections must be made a matter of record so that it will not be questioned at a later date.

- d. Load lines. Barges over 79 feet in length that transit beyond established boundaries must have load lines. If a load line assignment is not required, draft limitations may be imposed as a prerequisite to obtaining a COI when the OCMI judges such limitations to be necessary for the safety of life and property. See 46 CFR Subchapter E and, MSM Volume IV, Technical, COMDINST M16000.9 (Series) for load line requirements.

**NOTE:** Revisions to the statutory language governing loadline requirements in 46 U.S.C. 5102 have eliminated the exemption opportunity that vessels previously received from the wording in 46 CFR 42.03-5(b)(v). This revision makes load lines mandatory for all vessels which transit beyond the boundary line, including vessels conducting round-trip domestic “coastwise” voyages without visiting another U.S. port—so called “voyages to nowhere.” Until the regulations in Title 46 CFR are revised, this is the Coast Guard enforcement policy on load line requirements for vessels transiting beyond the boundary line, regardless of whether the vessel visits another port during that voyage.

- e. Lifesaving equipment. The requirements of 46 CFR Part 199 apply when seagoing barges are manned, whether the manning is required or permitted. The regulations permitting substitution of inflatable life rafts may be applied. Barges that do not sail more than 20 miles from a harbor of refuge and return to that harbor may be equipped with lifefloats or buoyant apparatus in lieu of lifeboats or inflatable life rafts.
- (1) Manning requirements. Certain barges may be unmanned if so authorized by the OCMI. However, if a crew is required by the OCMI--
- (a) 75 percent of the crew must be citizens of the United States if the barge is documented and whenever departing a port of the United States (see 46 U.S.C. 8103);
  - (b) 65 percent of the deck department, exclusive of licensed personnel, must be able seamen as defined in 46 U.S.C. 8702 (This may be reduced to 50 percent on vessels permitted to have a two-watch system.);
  - (c) On barges over 100 GT, all crewmembers must possess a Merchant Mariner's Document (MMC); and
  - (d) The watch system applies.
- (2) Permitted manning. When the OCMI does not require the presence of a crew, one may be permitted, provided that--



## SECTION B: DOMESTIC INSPECTION PROGRAMS

**CHAPTER 4: INSPECTION PROCEDURES APPLICABLE TO VESSEL TYPES, CLASSES, AND CATEGORIES**

- (a) Persons carried as maintenance persons must have no duties connected with navigation. A sample endorsement that may be used on the COI is:

*"Certificated without a navigating crew. The vessel may carry one person as maintenance person and operator of the dumping mechanism, with no duties connected with the navigation of the vessel."*

- (b) 75 percent of the personnel of the "permitted" crew are U.S. citizens, if the barge is documented and whenever departing a port of the United States (see 46 U.S.C. 8103); and
- (c) On barges over 100 GT, all crewmembers possess an MMC.

---

**3. Wooden Barges**

Particular attention should be given to the inspection of seagoing wooden barges. If such a vessel is not in drydock at the time of its inspection, a thorough examination of the structure must be made, insofar as possible. To this end, the ceiling may be lifted for examination of the framing as the marine inspector deems necessary. Should doubt as to the soundness of the structure remain, the vessel should be drydocked for further examination.

---

**4. Non-Self-Propelled Harbor Dredges and Barges; Change Places of Employment**

- a. Non-self-propelled harbor dredges and barges of 100 GT or more, when voyaging on the high seas to change places of employment, are subject to inspection and certification. 46 CFR 91.01-10(c) provides for a limited or short-term certificate, by which the vessel may be operated manned or unmanned. In those cases when the vessel is manned, the intent is to require a more thorough inspection than if it were unmanned.
- b. Plan approval. Plan approval is not required for the certification of such vessels.
- c. Inspections. The basic requirements for inspection of such vessels are contained in 46 CFR Subchapter I. It is the Commandant's policy that OCMI's apply the regulations liberally, bearing in mind the overall responsibility to ensure that vessels can be navigated safely.
- d. Load lines. When such vessels are not required to have a load line, the inspector must ensure that there are adequate closures to maintain watertight integrity for the

duration of the voyage. Draft limitations may be imposed as a prerequisite to obtaining a COI if the OCMI judges them to be necessary for the safety of life and property. Non-self-propelled dredges may carry spare parts for their own machinery without having them considered as cargo, if the OCMI judges the quantity and weight of such spare parts to be reasonable. See MSM Volume IV, Technical, COMDINST M16000.9 (Series).

- e. Lifesaving equipment. When vessels are manned, whether manning is required or permitted, the requirements of 46 CFR Part 199 apply. Substitution of inflatable life rafts may be permitted.
- f. Boilers. Some such vessels are equipped with boilers. If the boilers are going to be used during the voyage, they must be given such operating tests and examinations as the OCMI deems necessary to ensure their proper functioning throughout the voyage. When these boilers will not be used during any part of the voyage, they do not need to be inspected. Any unsafe or unsatisfactory conditions must be made a matter of record and the owner of the vessel so advised in writing by the OCMI.
- g. Wiring. Only the electrical wiring that will be energized during any part of the voyage is subject to inspection. Any unsafe or unsatisfactory condition detected must be made a matter of record and the owner of the vessel so advised in writing by the OCMI.
- h. Drydocking: domestic and foreign voyage vessels.
  - (1) Foreign voyage. A drydock examination of the underwater hull and outboard fittings of such vessels is a prerequisite to issuance of a COI, unless there is a record of a satisfactory drydock examination within the preceding 18 months.
  - (2) Domestic voyage. The OCMI will normally require a drydock examination unless there is acceptable evidence presented of a satisfactory drydock examination within the past 3 years.

## SECTION B: DOMESTIC INSPECTION PROGRAMS

**CHAPTER 4: INSPECTION PROCEDURES APPLICABLE TO VESSEL TYPES,  
CLASSES, AND CATEGORIES**
i. Manning: required and permitted.

- (1) Required manning. Such vessels may be towed unmanned if authorized by the OCMI. However, if a crew is required by the OCMI--
  - (a) 75 percent of the crew must be citizens of the United States, if the vessel is documented and whenever departing a port of the United States (see 46 U.S.C. 8103);
  - (b) 65 percent of the deck department, exclusive of licensed personnel, must be able seamen (for seagoing barges);
  - (c) On vessels over 100 GT, all crewmembers must possess an MMC; and
  - (d) The watch system applies (on voyages up to 600 miles only a two-watch system is necessary).
- (2) Permitted manning. When the OCMI does not require a crew on such vessels, one may be permitted, provided that--
  - (a) Persons carried as maintenance persons have no duties connected with navigation. A sample endorsement that may be used on the COI is:

*"Certificated without a navigating crew. The vessel may carry persons as maintenance persons with no duties connected with the navigation of the vessel."*

- (b) 75 percent of the personnel of this "permitted" crew are U.S. citizens, if the vessel is documented and whenever departing a port of the United States (see 46 U.S.C. 8103); and
- (c) On vessels over 100 GT, all crewmembers possess an MMC.

**5. Barges Operated on Sheltered Waters of British Columbia**

The sheltered waters of British Columbia were defined in a U.S.-Canadian treaty of 26 July 1934 as:

"The waters of Puget Sound, the waters lying between Vancouver Island and the mainland, and east of a line from a point one nautical mile west of the city limits of Port Angeles in the State of Washington to Race Rocks on Vancouver Island, and of a line from Hope Island, British Columbia, to Cape Calvert, Calvert Island, British Columbia, the waters east of a line from Cape Calvert to Duke Point on Duke Island, and the waters north of Duke Island and

east of Prince of Wales Island, Baranof Island and Chicagof Island, the waters of Peril, Neva and Olga Straits to Sitka, and the waters east of a line from Port Althorp on Chicagof Island to Cape Spencer, Alaska...." Barges of 100 GT and more making voyages on sheltered waters of British Columbia should not be inspected as seagoing barges.

---

## **6. Towing of Vessels to be Scrapped**

See Chapter B1 of this Manual.

---

## **7. Ship Hulls used as Seagoing Barges**

Ship hulls operated under the U.S. flag as seagoing barges to deliver cargo and scrap to foreign countries are subject to the following minimal requirements:

- a. The vessel must comply with the regulations governing cargo stowage and securing arrangements. Approval of these arrangements by the National Cargo Bureau, Inc. (NCB) may be accepted as prima facie evidence of compliance.
- b. A load line is required.
- c. Inspection is required (including a drydock examination if necessary), followed by certification as a seagoing barge.
- d. Should the vessel be manned, the following manning and equipment requirements are applicable:
  - (1) The vessel must be manned by a master and at least six mariners;
  - (2) Sufficient primary lifesaving equipment for all persons on board is required. A lifeboat (carried in such a manner that it may be readily launched) or life raft is acceptable;
  - (3) Means for pumping bilges and discharging normal amounts of bilge water must be provided;
  - (4) Provision should be made to supply electric power, when applicable to loads covered by 46 CFR 112.15; and
  - (5) Sufficient firefighting equipment should be provided to cope with any fire that may be anticipated during the voyage.

**NOTE:** For operations under a foreign flag, the vessel must possess a valid Load Line Certificate. Requirements other than these must be imposed by the vessel's home administration or insurance underwriters, etc., not by the Coast Guard.

## SECTION B: DOMESTIC INSPECTION PROGRAMS

**CHAPTER 4: INSPECTION PROCEDURES APPLICABLE TO VESSEL TYPES, CLASSES, AND CATEGORIES****8. Inland Tank Barge Pressure Vacuum (PV) Valve Requirement (46 CFR 39.20-11)**

46 CFR 39.20-11 requires that cargo tank Pressure vacuum (PV) valves be set not lower than 1 psig and 0.5 psig on the vacuum side. Some inland tank barge cargo tanks are not structurally designed for pressures and vacuums. During Vapor Control System (VCS) plan review, these barges were approved by the Coast Guard with PV valves set below those required by 46 CFR Part 39, to protect the structure of the barge.

- a. The lower PV valve settings have resulted in problems at some facilities attempting to conduct VCS operations with these barges.

- (1) Such problems range from very slow transfer rates to the inability to conduct transfer. Provided that transfer procedures are followed, these are operational, not safety issues, since the tank venting system still serves to protect the cargo tanks from over/under pressurization during VCS operations. Vessel operators may continue to operate with these PV valve settings if they so desire.

- (2) However, if the owner/operator decides to upgrade the pressure settings or if the barge is displaying obvious signs of over-pressurization, then additional plan review or approvals may be necessary.

- b. The Marine Safety Center (MSC) will enter PV valve settings in the MISLE database (Vessel File Cargo Systems product set) for all future planned reviews of VCS. OCMI's must make these entries when they are not made by MSC and verify the PV valve is approved for the set pressures during routine scheduled inspections.

---

**9. Great Lakes Barges**

**46 USC § 2101 defines a "Great Lakes barge" as a "non-self-propelled vessel of at least 3,500 gross tons operating on the Great Lakes." Inspection is required under Public Law 102-587. This guidance is provided pending promulgation of regulations.**

- a. **Plan Review.** Full plan review is required prior to initial certification of any Great Lakes barge. Certain hull structure and system plans may be exempt from review, based on load line surveys, recognized classification society certificates, or operating history, as deemed appropriate by the cognizant Officer in Charge, Marine Inspection (OCMI).
- b. **Hull Survey and Credit Drydocking.** A complete internal inspection and credit drydocking are required at intervals not to exceed 5 years, not withstanding extensions approved under Section B.3.A.4.d.8 of this Manual.

## SECTION B: DOMESTIC INSPECTION PROGRAMS

**CHAPTER 4: INSPECTION PROCEDURES APPLICABLE TO VESSEL TYPES,  
CLASSES, AND CATEGORIES**

c. **Inspection for Certification.** Application of all requirements for seagoing barges contained in Title 46, Code of Federal Regulations (CFR) Subchapter I, is required, along with associated subtitles related to pollution prevention, navigation safety, and marine transportation security. Manned and permissively manned barges must meet the applicable requirements for cargo vessels on a Great Lakes route contained in 46 CFR Subchapter W.

d. **Operation.**

(1) For tug/barge combinations operating in the Push-Mode, as defined in Navigation and Vessel Inspection Circular (NVIC) No. 2-81, or when equipment on the barge unreasonably restricts the visibility of the tug operator, or when the configuration of the tug/barge combination is such that "the person in charge of navigation maintains control from a fixed steering station on the barge," the following manning requirements will apply:

(a) The tug/barge configuration shall be manned as a single vessel utilizing a three watch system.

(b) The master and mates must hold inspected vessel licenses with tonnage limitations appropriate to the combined tonnages of the tug and barge.

(c) The manning scale below should be used as a guide.

- i. 1-Master/1st Class Pilot
- ii. 1 - Chief Engineer
- iii. 3-Mates/1st Class Pilots
- iv. \* Assistant Engineers
- v. 6-Able Seamen
- vi. \*Oilers

Note: \* Dependent on automation level of equipment.

(2) For tug/barge combination operating in the Dual-Mode, as defined in NVIC 2-81, with navigation control of the tow exclusively on the tug, the manning level shall be commensurate with that required for the tug (ref: 46 U.S. Code part F).

(3) For barges that require specially trained personnel on board to operate self-unloading equipment/systems, or to monitor cargo and ballast systems, an endorsement shall be placed on the certificate of inspection

(similar to that for tankermen), as deemed appropriate by the cognizant OCMI.

---

---

**F. MOBILE OFFSHORE DRILLING UNITS (MODUs)**

---

**1. Introduction**

MODUs are inspected and certificated under 46 CFR Subchapter I-A, which requires an inspection for certification every 2 years and a reinspection between the 10th and 14th month after issuance of the certificate. MODUs operating on the U.S. Outer Continental Shelf (OCS) are required to have annual onsite inspections in accordance with the OCS Lands Act Amendments of 1978 (43 U.S.C. 1331, et seq). Self-propelled MODUs of 500 or more GT engaged in international voyages are subject to the requirements of SOLAS 74/78. These units have the option of compliance with SOLAS or with the IMO MODU Code. U.S. flag MODUs are subject to Coast Guard inspection requirements any time the vessel is operating (46 U.S.C. 3311). Therefore, unless "laid-up," a U.S. flag MODU must be in compliance with its COI regardless of its location or whether floating or bottom bearing. Consequently,

regardless of the vessel's location, mode of operation, or types of international certificates, a U.S. flag MODU will receive an inspection or reinspection annually.

---

## **2. IMO MODU Code**

- a. On 26 July 1982, the Commandant advised the Secretary General of the IMO that the United States accepted the organization's MODU Code as equivalent to the requirements of SOLAS 74/78 for such vessels. As noted above, MODUs may comply with SOLAS or with the terms of the IMO MODU code. In addition, there will be a number of MODUs not subject to SOLAS for which IMO Code certificates are desired. Revision of 46 CFR Subchapter I-A has been initiated by Commandant (CG-543). One of the stated objectives of the regulatory workplan is to dovetail Subchapter I-A with the IMO MODU Code.
  - b. Administration. Upon request of the vessel owner, U.S. MODUs should be inspected to verify compliance with the IMO MODU Code. It is anticipated that such inspections will be conducted in conjunction with inspections for certification.
    - (1) Should a conflict exist between the IMO MODU Code and the provisions of 46 CFR Subchapter I-A, the owner must either request an exemption under paragraph 1.4 of the IMO MODU code or the Coast Guard must determine equivalency under paragraph 1.5 of the IMO MODU code.
    - (2) Upon satisfactory completion of the inspection, a MODU Safety Certificate, CG-5334 must be issued to the vessel. The certificate should be dated to expire 2 years from the date of the inspection.
- 

## **3. U.S. Flag MODUs Operating in Foreign Waters**

- a. Full compliance with the U.S. regulations may be difficult for MODUs operating in foreign waters and subject to coastal state requirements. When another country's requirements conflict with U.S. requirements, U.S. Coast Guard regulations must take precedence unless an exception is specifically authorized by the cognizant OCMI.



## SECTION B: DOMESTIC INSPECTION PROGRAMS

**CHAPTER 4: INSPECTION PROCEDURES APPLICABLE TO VESSEL TYPES,  
CLASSES, AND CATEGORIES**

- b. 46 CFR 111.105 requires explosion-proof and intrinsically safe systems to be "listed by Underwriters Laboratories, Inc., Factory Mutual Research Corp. or other independent laboratory acceptable to the Commandant." Other laboratories that are acceptable are the Canadian Standards Association (CSA) and MET Testing Laboratory. However, requiring electrical equipment to be listed by these North American laboratories is not always reasonable in foreign waters because such equipment may not be available, or it may not meet coastal state equipment listing requirements. For subcontractor equipment or other temporary installations, other independent laboratories are acceptable for listing explosion-proof equipment and intrinsically safe systems.
- (1) Subcontractor services. Drilling operations aboard MODUs often require subcontractor services. Subcontracted services include, among others, well logging, cementing, and casing perforation. Typically, these services are obtained locally by the leaseholder without regard to vessel flag. Contractor electrical equipment usually meets the certification requirements of the coastal state, and not necessarily those of the vessel's home administration. These installations are considered temporary although they may be installed for a few days or a few years.
- (2) Temporary installations. For temporary installations, equipment approved by an independent laboratory acceptable to the coastal state may be permitted by the OCMI in whose zone the vessel is operating.
- (a) When the coastal state has no certification requirements, equipment must be listed by one of the North American laboratories previously indicated, by one of the agencies listed at the end of this subpart, or by another agency acceptable to Commandant (CG-ENG).
- (b) In no case should equipment required by 46 CFR 111.105 to be listed, i.e., explosion-proof (flameproof) equipment or intrinsically safe systems, be permitted based on manufacturer or classification society certification. Upon return to U.S. waters and prior to engaging in OCS activities, MODUs must utilize equipment listed by one of the North American laboratories.
- (c) Listed below are independent laboratories that are acceptable, provided they are recognized by the coastal state. This list is not intended to be all-inclusive; other laboratories acceptable to the coastal state may be permissible.
-

#### 4. Recognized International Testing Laboratories

Country	Symbol	Organization
Belgium	INIEX	Institut Nationale des Industries Extractives
Denmark	DEMKO	Danmarks elektriske materielkontrol
France	LCIE	Laboratoire centrale des industries electriques
	CERCH AR	Centre d'Etudes Recherches des Charbonnages de France
Italy	CESI	Centro Elettrotecnico Sperimentale Italiano
Norway	NEMKO	Norges Elektriske Materiallkontroll
U.K.	BASEE FA	British Approvals Service for Electrical Equipment in Flammable Atmospheres
Germany	PTB	Physikalisch-Technische Bundesanstalt
	BVS	Berggewerkschaftliche Versuchsstrecke

---

#### G. DRILLING TENDERS

---

##### 1. Introduction

Artificial islands and structures erected on the OCS to support the development of mineral resources may be regarded as "places in the United States" for purposes of the navigation and vessel inspection laws. Accordingly, a drilling tender that is moored to one of these artificial islands or structures may be considered to be "at a port or place in the U.S."

---

##### 2. Inspection Procedures

- a. Special agreements. Certain inspection agreements have been made with respect to drilling tenders engaged exclusively in providing power, machinery, and accommodations for material and personnel used in underwater drilling, mining, and related production operations. Such vessels are normally anchored for several months at a time at one location, and move only when proceeding to a new drilling site or a shipyard. Some of these vessels are self-propelled and others are not. They are all inspected and certificated under Subchapter I.
- b. Drydocking. Requests received by an OCMI other than the OCMI who conducted the vessel's last inspection for certification should not be granted until they are approved by the last certificating OCMI. Appropriate inspection of the vessel is a prerequisite

**SECTION B: DOMESTIC INSPECTION PROGRAMS****CHAPTER 4: INSPECTION PROCEDURES APPLICABLE TO VESSEL TYPES, CLASSES, AND CATEGORIES**

to granting an extension in all but the most unusual circumstances. Underscantling vessels such as Landing Ships, Tank (LSTs) should not be granted extensions.

- c. Examinations of tailshafts and stern tube bearings. Due to their limited amount of time underway, drilling tenders need not have their tailshafts drawn for examination until the wear down exceeds the maximum permitted by 46 CFR 61.20-15. This should be handled on an individual basis, upon written request by the vessel owner. Extensions should be granted in writing, in a manner similar to an authorization to extend the drydocking interval. The vessel's COI must show the date when the tailshaft was last drawn, with a notation concerning the extension.
- d. Additional requirements. The standards discussed above do not affect the prerogative of the OCMI to require drydocking or other inspection procedures at any time for cause. Copies of all owner requests and letters of authorization must be sent to Commandant (CG-CVC) and the last certificating OCMI.

**3. Delivery of Excess Fuel to Drilling Platforms**

Under 46 U.S.C. 3702(b), certain Offshore Supply Vessels (OSVs) are permitted to transfer fuel from their own fuel tanks to offshore drilling or production facilities without being inspected and certificated as tank vessels. Specifically, 46 U.S.C. Chapter 37 does not apply to a documented vessel under these circumstances provided that the vessel in question is not more than 500 GT, it is not a tanker, and it is in the service of oil exploration. A requirement for this exemption is that the person in charge of transfer operations must be a certified tankerman.

**H. OCEANOGRAPHIC RESEARCH VESSELS (ORVs)****1. Introduction**

Oceanographic Research Vessels (ORVs) must receive inspections for certification and reinspections in accordance with 46 CFR Subchapter U (Oceanographic Research Vessels). Classification as an ORV requires a determination by the Coast Guard. To arrive at such a determination, an analysis of the particulars of service, method of operation, and classes of persons carried should be conducted. For uninspected vessels claiming to be less than 300 GT, tonnage measurement may be a part of this analysis.

**2. Accommodations**

Accommodations for officers, crew, and scientific personnel must comply with the requirements of 46 CFR 190.20. However, members of deck and engine groups that stand watch at the same time may be quartered together. In addition, special consideration must be given to accommodations for scientific personnel carried on voyages of 14 days or less, provided the general intent of 46 CFR 190.20-5 is met. A space intended as a hospital space under the requirements of 46 CFR 190.20-35(a) may be used for ordinary berthing on voyages of 3 days or less.

---

### **3. Scientific Personnel**

Scientific personnel are not classed as either "mariners" or as "members of the crew," but as "other persons" engaged on board for the purpose of conducting the business of the vessel. The carriage of scientific personnel must be indicated by separate endorsement on the COI and reflected in the "Total Persons Allowed."

---

### **4. Uninspected Vessels Used as ORVs**

- a. Letters of designation. Owners/operators of uninspected, seagoing motor vessels of less than 300 GT and any uninspected motor vessels operating on the Great Lakes that are intended to be operated as ORVs may request a Letter of Designation as an ORV under 46 U.S.C. 2101(18).
  - (1) After determining that such a vessel is employed exclusively in oceanographic research, the OCMIs must issue a Letter of Designation valid for a period of 2 years (see Figure 10-2 for a sample letter). This letter designates the vessel as an ORV, and advises the owner/operator that the vessel must maintain exclusive employment in oceanographic/limnologic research or instruction and that any deviation from such exclusive use may constitute violations of the inspection statutes.
  - (2) In prior administrative rulings, the study of celestial navigation, seamanship, scuba diving, and other topics, in conjunction with oceanographic research or instruction, has voided a vessel's claim of exclusive employment. Additionally, a vessel documented as a pleasure vessel under 46 U.S.C. 12109 may not secure an ORV designation without surrendering its document, as the vessel would not be used exclusively for pleasure.
  - (3) OCMIs should not normally designate a vessel routinely carrying minor children as an ORV. Due to reduced safety requirements for ORVs, and the unique needs and capabilities of children, ORV designation is most often inconsistent with marine safety objectives for carriage of minor children. If confronted with a legacy vessel designation where the vessel routinely carries minor children, the COMI should consult with CG-CVC and CG-0941 staff prior to renewing the ORV designation.

## SECTION B: DOMESTIC INSPECTION PROGRAMS

**CHAPTER 4: INSPECTION PROCEDURES APPLICABLE TO VESSEL TYPES, CLASSES, AND CATEGORIES**

- b. Evaluation by the OCMI. It is the Commandant's policy that the vessel should be able to retain its designation under 46 CFR 3.10-5, even though the terms of its charter or specific oceanographic work may vary periodically. However, if a change of employment or operating conditions deviates from exclusive oceanographic research/limnologic activities, the owner/operator or master must advise the OCMI who granted the designation.
- (1) Taking into account the particulars of the case, the OCMI must determine the eligibility of the vessel to retain its ORV designation based on its new employment/operations.
  - (2) If the vessel is not eligible to retain its ORV designation, it may be subject to inspection under (for example) 46 CFR Subchapter T or I. A formerly designated vessel, upon returning to bona fide oceanographic/limnologic activities, may be considered for a new ORV designation.
  - (3) If all operating conditions are as originally accepted, the information given for the initial request need not be resubmitted. The issuing OCMI and Commandant (CG-CVC) must retain copies of the Letter of Designation.
- c. Research operations not under a Letter of Designation. An uninspected seagoing motor vessel of less than 300 GT or an uninspected motor vessel of any size operating on the Great Lakes that does not possess a Letter of Designation may engage in oceanographic research operations, provided that such use does not violate applicable manning and inspection requirements.
- (1) Such a vessel must not be considered an ORV for purposes of 46 CFR Parts 3, 14, 24, and 188-189. Furthermore, scientific personnel who serve in any capacity aboard an undesignated vessel of at least 100 GT require MMCs as members of the crew.
  - (2) Carriage of students would be considered carriage of passengers, which would compel inspection, depending on the size of the vessel and the number of students/passengers carried. The designation procedure is, however, purely voluntary in nature and needed only where equitable relief from otherwise applicable inspection or shipment and discharge requirements is desired.
- d. Appeals of evaluation. An adverse decision of an OCMI regarding any Letter of Designation request may be appealed to the district commander and to Commandant (CG-CVC), according to the procedures outlined in 46 CFR 2.01-70.
-

**FIGURE B4-2**

**SAMPLE LETTER OF DESIGNATION FOR AN  
OCEANOGRAPHIC RESEARCH VESSEL**

(On Official OCMI's Letterhead)

[Date]

Name of Vessel Owner/Operator]

[Address]

Subj: Letter of Designation as an Oceanographic Research Vessel,  
[Name of Vessel and O.N.]

Dear Sir:

In accordance with the provisions of Title 46, United States Code, 2101 (18), the [Vessel Name and O.N.] is hereby designated an oceanographic research vessel. This designation shall remain in effect until [Date 2 Years From Date of Letter], provided the vessel does not change employment or deviate from engaging exclusively in oceanographic research operations. Any such changes or deviations may constitute violations of inspection laws and must be reported to this office by the master, owner, or agent of the vessel. A determination will then be made regarding the vessel's eligibility to retain this designation.

A request for renewal of this designation should be made by [date, 60 days prior to expiration]. This letter shall be maintained on board the vessel.

Sincerely,

[Signature]

[Title]

Copy: Commandant (CG-CVC)  
CCGD(m)

---

**SECTION B: DOMESTIC INSPECTION PROGRAMS****CHAPTER 4: INSPECTION PROCEDURES APPLICABLE TO VESSEL TYPES, CLASSES, AND CATEGORIES****5. Public Vessels**

Public (e.g., U.S. Navy and National Oceanic and Atmospheric Administration (NOAA)) vessels as defined in 46 U.S.C. 2101(24) operated for oceanographic research are not required to be inspected and certificated by the Coast Guard. However, such vessels may be inspected and certificated upon request by the parent agency and upon an interagency agreement to this effect. When public vessels are alternatively furnished a letter indicating some degree of compliance with the regulations, every effort should be made to obtain one compartment subdivision and damage stability calculations when only 100 percent lifeboatage is provided.

**NOTE:** Refer to Chapter B5 of this Manual; Inspection of Public Vessels.

---

**I. CRAFT ROUTINELY OPERATED DOCKSIDE (C-ROD)**

---

**1. Purpose and Intent**

- a. The intent of this part is to give the COTPs/OCMI's guidance in determining if a Craft that is Routinely Operated Dockside (C-ROD) a vessel and subject to Inspection for Certification. Some examples of such C-RODs are showboats, theaters, hotels, gaming sites, restaurants, museums, attraction vessels, and business offices either self propelled or not.
  - b. This policy applies to any craft, including existing craft, that routinely operates dockside and does not usually get underway.
  - c. This policy does not apply to semi-submersible platforms, which are not listed as "vessels subject to inspection" under 46 U.S.C. 3301. Based on their work on the OCS, semi-submersible platforms are inspected under 43 U.S.C. 1333.
  - d. Nothing in this policy alters requirements for attraction vessels outlined in Section B of this Manual. While attraction vessels may be considered to be routinely operated dockside, they are still vessels.
  - e. OCMI's are not required to make any Vessel/PMC determinations unless an application for inspection is submitted to the OCMI by the craft operator and the OCMI has reason to believe the craft is or will not be a vessel.
-

## 2. Discussion

- a. In 2005, the Supreme Court issued its decision in *Stewart v. Dutra Construction Company, Inc.*, 543 U.S. 481, 125 S.Ct. 1118 (2005). That case held that a dredge is a “vessel” under 1 U.S.C. 3. The Supreme Court decided that 1 U.S.C. 3 provides the defining criteria for determining what constitutes a vessel wherever the U.S.C. refers to “vessel” as a jurisdictional criterion. In determining whether a particular craft is also a vessel, the “question remains in all cases whether the watercraft’s use ‘as a means of transportation on water’ is a practical possibility or merely a theoretical one.” 543 U.S. at 496.
- b. Prior to this Supreme Court decision, various circuit courts of appeal had applied different tests to determine whether a particular craft was a vessel, depending on statute and the individual facts of each case.
- c. Historically, the Coast Guard attempted to apply the different tests so as to provide maximum flexibility in achieving the purpose of the particular statute being administered. After *Stewart v. Dutra Construction Company, Inc.*, it is clear that an OCMI must apply the single test of whether a craft is used, or is practically capable of being used, as a means of transportation on water.
  - (1) *Stewart v. Dutra Construction Company, Inc.* implies that a “permanently moored vessel” is an oxymoron, since such a craft is neither used nor practically capable of being used as transportation on water, and therefore cannot be considered a vessel.
  - (2) Only a vessel can be inspected by the Coast Guard under the authority of 46 U.S.C. 3301.
- d. In order to conform to *Stewart v. Dutra Construction Company, Inc.*, an OCMI will only issue Certificates of Inspection to craft that routinely operate dockside and do not normally get underway if they also constitute “vessels” as defined in 1 U.S.C. 3 and interpreted in *Stewart v. Dutra Construction Company, Inc.*.
- e. The Coast Guard published a Notice of Policy in the *Federal Register* on May 11, 2009 announcing this change. (FR Vol. 74 No. 89 page 21814; Docket No. USCG–2004–17674.)

## 3. Definitions

- a. Craft means any artificial contrivance designed to float or operate on the water including “vessels” as defined below. Every vessel is a craft, but not every craft is a vessel.
- b. Craft Routinely Operated Dockside (C-ROD) means a craft which engage in commercial operations at its moorings without getting underway. C-RODs include both permanently moored craft and vessels.



## SECTION B: DOMESTIC INSPECTION PROGRAMS

**CHAPTER 4: INSPECTION PROCEDURES APPLICABLE TO VESSEL TYPES, CLASSES, AND CATEGORIES**

- c. Permanently Moored Craft (PMC) means a craft of design and mooring arrangement such that they do not have a practical capability of being used as transportation on the water.
- d. Vessel, as defined in 1 U.S.C. 3, includes every description of watercraft or other artificial contrivance used, or capable of being used, as a means of transportation on water.

---

**4. Vessel or PMC Determination**

- a. If there is a question as to whether any specific craft is or will be a vessel as defined in 1 U.S.C. 3 and interpreted in *Stewart v. Dutra Construction Company, Inc.*, it is up to the cognizant OCMI to make such a determination.
- b. If an owner or operator submits an Application for Inspection to the OCMI, the OCMI will evaluate the craft in accordance with this part and will advise the craft's owner or operator of this determination in writing, as well as any appeal rights should the owner or operator wish to contest the OCMI's determination.
- c. In order to be inspected and certificated as a vessel by the Coast Guard, the craft owner or operator must demonstrate, to the OCMI's satisfaction, the craft's practical capability to operate as a means of transportation on water. When determining if a craft possesses this capability, OCMI's and vessel owners should consider the questions included in the non-exclusive list following this paragraph. This list should be considered under the totality of the circumstances presented in each instance:
  - (1) Is the craft surrounded by a cofferdam, land, or other structure, such that although floating, it is in a "moat" with no practical access to navigable water?
  - (2) Is the craft affixed to the shore by steel cables, I-beams, or pilings; or coupled with land based utility connections for power, water, sewage, and fuel?
  - (3) If the craft were operated in navigation, would it be thereby endangered because of its construction?
  - (4) What is the purpose, function, or mission of the craft?

- (5) Can the craft get underway in less than 8 hours? If more than 8 hours are required, the OCMI will determine if the delay was attributable to factors outside the owner's or operator's control, in which case the delay may be overlooked.
- c. "Getting underway" consists of operating in the navigation channel and conducting propulsion tests, steering tests, and drills including the launching of rescue boats, all to the satisfaction of the OCMI. This may occur at the time of inspection for certification or at least annually. Non-self propelled craft may get underway with the assistance of an appropriate towing vessel. A craft that cannot demonstrate its ability to get underway to the satisfaction of the OCMI will be deemed a land structure and will no longer be inspected for certification by the Coast Guard, except for temporary grandfathering of certain PMCs.
- 

#### **5. C-ROD Determined to be Vessels**

- a. C-ROD determined to be vessels by the OCMI must demonstrate their practical use as transportation on the water through compliance with Paragraph I.4.c of this Chapter.
- b. Craft that have been determined to be vessels are subject to all applicable requirements, including Coast Guard inspection and certification requirements. Such craft must remain in compliance with approved plans at all times, even if they do not normally get underway but routinely engage in dockside operations.
- c. The Coast Guard may grant authorized exceptions and equivalencies. For example, 46 CFR Part 199 allows an OCMI to conduct a safety assessment on passenger vessels over 100 tons by using risk based decision-making principles to allow departures from traditional lifesaving equipment requirements. Sliding scale manning tables have also been found acceptable.
- 

#### **6. C-ROD Determined to be PMCs**

- a. If a craft owner/operator submits an Application for Inspection to the OCMI and the OCMI determines a craft to be a PMC rather than a vessel, the OCMI must provide the owner/operator a letter stipulating this determination.
- (1) The OCMI should provide a copy of this letter to appropriate authorities such as the USACE, EPA, fire marshal, building inspector, or other government agency that would have regulatory authority over the structure to ensure appropriate parties are aware to the Coast Guard determination.
- (2) An example of such a letter is included at the end of this Part.
- b. Craft built with the intent to be PMCs should comply with applicable local building codes or regulations specified by the local jurisdiction. The Coast Guard will not

**SECTION B: DOMESTIC INSPECTION PROGRAMS****CHAPTER 4: INSPECTION PROCEDURES APPLICABLE TO VESSEL TYPES, CLASSES, AND CATEGORIES**

provide inspection oversight to any craft that intends to operate as a PMC or that cannot demonstrate that it is or will be a vessel as described in this part.

---

**7. Change of Status**

- a. The OCMI must take appropriate action to determine PMC status in accordance with the provisions of this Part when a certificated vessel changes its operations or configuration such that it may no longer be considered a vessel.**
- (1) An operator must advise the OCMI of their intent to convert a vessel to a PMC.**
  - (2) An operator must also advise the OCMI of their intent to operate as a PMC storing oil for transfer to or from shore. See Section B.4.D.1 of this Manual for risks and other government agency notifications that should be evaluated for Permanently Moored Tank Craft.**
  - (3) An operator must submit a Letter of Intent to the COTP requesting designation as a 33 CFR Part 154 facility if they intend to operate as a PMC storing oil or hazardous materials for transfer to or from a vessel.**
  - (4) The OCMI should be satisfied that the proposed operation and craft configuration are such that the craft is no longer considered a vessel in accordance with the guidance in this Part. If the OCMI determines the craft in question is no longer a vessel, the COI must be surrendered and the action documented in MISLE.**
  - (5) The OCMI/COTP should coordinate regulatory oversight transition to the appropriate federal, state and local government agencies; e.g., USACE, EPA, and fire marshal.**
-

## 8. Local or State Authorities

Any craft that has been determined to not be a vessel is not subject to Coast Guard inspection law and regulation and becomes the jurisdiction of the state or local government. The craft must comply with either local building codes or applicable standards as stipulated by the appropriate state or local government entity.

---

## 9. Waterways Management

- a. PMCs are considered to be structures on the water and must be permitted by the United States Army Corps of Engineers (USACE) as appropriate.
  - (1) The USACE has the sole authority to issue site permits.
  - (2) Per the Coast Guard/USACE Memorandum of Agreement in MSM Volume X, Interagency Agreements and Acronyms, COMDTINST M16000.15A (Series), the USACE will seek COTP input on new site permit applications and approvals at the earliest opportunity.
  - (3) The COTP may address concerns for navigation safety or other waterways management issues by providing comment to the USACE during the permitting process.
- b. As PMCs are not vessels, the COTP cannot compel operators to undergo a formal risk assessment prior to placing the craft in its location or intended operation.
  - (1) COTPs should work closely with the cognizant USACE District Engineer to identify and mitigate navigation safety concerns.**
  - (2) Mooring arrangements must be acceptable to the COTP; they must pose no risk to the port, waterway, or environment and must be capable of withstanding the location's wind, ice, and water conditions.**
  - (3) Special consideration must also be given to extreme weather that may occur, including, but not limited, to hurricane force winds, current, or high water.**
  - (4) PMCs storing oil or hazardous materials for transfer to or from a vessel must satisfy 33 CFR Parts 154, and 156 requirements.**
- c. **PMCs storing oil for transfer to or from shore must satisfy EPA secondary containment requirements.**
  - (1) The EPA's Oil Pollution Prevention requirements (spill prevention, control and countermeasure plans) in 40 CFR Part 112 are applicable to non-transportation related facilities (Permanently Moored Tank Craft).**

## SECTION B: DOMESTIC INSPECTION PROGRAMS

**CHAPTER 4: INSPECTION PROCEDURES APPLICABLE TO VESSEL TYPES,  
CLASSES, AND CATEGORIES**

- d. **OCMIs should notify the cognizant USACE District Engineer and the Regional EPA Administrator when vessel owners/operators initiate a change in a craft's status to a PMC. The OCMI should also advise the craft owner/operator to seek the appropriate permits from the USACE and EPA.**
- (1) **Permits are the responsibility of the owner/operator and are not tied to any determination by the OCMI or COTP.**
  - (2) **OCMIs should not delay determinations of PMC status, nor should OCMIs compel continued compliance with Coast Guard Vessel Inspection regulations, in the absence of or while waiting for the owner/operator to obtain an USACE permit.**
- e. **The COTP may require lighting of the PMC under the provisions of 33 CFR Part 64.**

---

**10. Vessel Documentation**

- a. Craft that are determined not to be vessels are ineligible for vessel documentation. In situations where such a craft holds a valid Certification of Documentation (COD), that COD would become invalid because the craft no longer meets the requirements of 46 U.S.C. 12135. The owners would then be required to surrender the COD. The OCMI shall notify the National Vessel Documentation Center (NVDC) of any craft that holds a Certificate of Documentation and is determined no longer to be a vessel. The OCMI must also advise the craft operator of its ineligibility.
- b. When the craft is the subject of an outstanding mortgage properly filed or recorded in accordance with 46 U.S.C. Chapter 121 and applicable regulations, the COD, but not the trade endorsement thereon, remains valid for certain purposes. The COD would remain valid for the purposes of 46 U.S.C. Chapter 313 and instruments filed or recorded before the date of invalidation, including the craft's current, preferred, mortgage and assignments or notices of claim of lien filed after that date. See 46 CFR 67.161.
- c. If the craft owners plan to refinance or obtain additional financing, the new mortgage could not be recorded as outlined in 46 U.S.C. Chapter 313 and would not be able to enjoy the protections of preferred mortgage status under that chapter. The same is true for any mortgages the owners might plan to obtain in the future after the current mortgage has been satisfied, unless the craft is altered so that it is eligible to regain its status as a vessel.

## **11. MISLE Activity**

- a. Newly built craft that are not deemed vessels will not be entered into the MISLE database as vessels. Field units will change the MISLE status of any former vessels in MISLE that becomes permanently moored such that they no longer meet the definition of vessel to “DEACTIVATED.” COIs will be removed from these craft and deactivated.**
- b. Newly built craft and vessels converted to PMCs that operate as a Facility Transferring Oil or Hazardous Materials in Bulk to or from a vessel should have their 33 CFR Part 154 facility status noted in MISLE.**
- c. Retain all historical vessel inspection records in MISLE for vessels converted to PMCs. These records should be provided to federal, state or local agencies that have jurisdiction over the PMC.**

---

## **12. Correspondence**

**An example of a PMC determination letter is provided in the following page.**

USCG Marine Safety Manual, Vol. II: Materiel Inspection

## SECTION B: DOMESTIC INSPECTION PROGRAMS

## CHAPTER 4: INSPECTION PROCEDURES APPLICABLE TO VESSEL TYPES, CLASSES, AND CATEGORIES

U.S. Department of  
Homeland Security

United States  
Coast Guard



Commander  
United States Coast Guard  
Sector Hianisport

2100 Second Street, S.W.  
Homeport, 12345  
Staff Symbol:

Owner or Operator

16700

Dear Sir or Madam:

The Officer in Charge, Marine Inspection (OCMI) of Coast Guard Sector Homeport, USA, has determined that your craft NEVER SAIL, for which you submitted an Application for Inspection on January 1, 2010, is not a vessel as defined in 1 U.S.C. 3 due to its configuration, intended use, or mooring arrangement that prohibits it from a practical use as transportation on the water. Therefore, it is not subject to U. S. Coast Guard vessel inspection regulations and the Coast Guard cannot provide inspection oversight or issue a Certificate of Inspection **to it**. This craft is also ineligible for documentation as a vessel.

As the craft is considered to be substantially a land structure on the water, you will need to apply for an appropriate permit from the U. S. Army Corps of Engineers. **If you operate the craft as a floating oil storage facility you will need to comply with Environmental Protection Agency spill prevention, control and countermeasure plan requirements. If you intend to operate the craft as a floating oil storage facility that transfers oil or hazardous materials to or from a vessel you will need to submit a Letter of Intent to the cognizant Captain of the Port (COTP) and comply with the spill prevention requirements in 33 CFR Part 154.**

**You may also be required by the COTP to verify the suitability of the mooring arrangements to withstand the forces of wind, current, ice and high water. If there is a change in the approved mooring arrangements, you shall contact the cognizant COTP to update the statues. Lastly, you may also be required to comply with appropriate local building codes or other standards as may be stipulated by the state or local government.**

If your craft's status changes such that it is placed into navigation or otherwise has a practical use for transportation on the water, you must then fully comply with all applicable vessel inspection laws and regulations. Such a change in status must be reported to this office or cognizant OCMI prior to any return to navigation so that an appropriate inspection may occur.

If you have any questions about this determination you may contact LCDR M. I. Inspector, Chief, Inspections Department at (123) 555-1234.

Sincerely,

J. A. SMITH  
Captain, U. S. Coast Guard  
Officer in Charge, Marine Inspection

USCG Marine Safety Manual, Vol. II: Materiel Inspection

**SECTION B: DOMESTIC INSPECTION PROGRAMS**

**CHAPTER 4: INSPECTION PROCEDURES APPLICABLE TO VESSEL TYPES,  
CLASSES, AND CATEGORIES**

**COPY: COMMANDER (DP), COAST GUARD DISTRICT X  
U. S. ARMY CORPS OF ENGINEERS, HOMEPORT, USA DISTRICT  
NATIONAL VESSEL DOCUMENTATION CENTER  
EPA [APPROPRIATE REGION] ADMINISTRATOR  
(APPLICABLE STATE OR LOCAL AGENCY)**



USCG Marine Safety Manual, Vol. II: Materiel Inspection

**SECTION B: DOMESTIC INSPECTION PROGRAMS**

**CHAPTER 4: INSPECTION PROCEDURES APPLICABLE TO VESSEL TYPES,  
CLASSES, AND CATEGORIES**

**POLICY CONTINUES ON B4-50.**

## J. BOY SCOUT VESSELS

---

### 1. Introduction

To assist local Boy Scout councils, chartering organizations, and leaders in complying with Coast Guard inspection regulations, the Boy Scouts of America's (BSA's) Exploring Division and the Coast Guard entered into formal agreement on 1 October 1979. Vessels associated with the BSA's Exploring Division are known as Sea Explorer vessels. Although the agreement principally addresses the Sea Explorer program, it applies equally to all vessels operated in the interests of the BSA. The Exploring Division intends that all Sea Explorer vessels, except pulling boats carrying no more than six passengers, will be inspected and certificated.

---

### 2. Inspection Procedures

- a. Vessels inspected under 46 CFR Subchapter T. All Sea Explorer vessels under 100 GT that carry more than six Boy Scouts must be inspected and certificated under 46 CFR Subchapter T.
  - (1) These vessels are subject to inspection because the Boy Scouts carried are considered to be passengers, as defined in 46 U.S.C. 2101(21)(B).
  - (2) In the past, a strict interpretation of the law did not require inspection and certification of vessels over 65 feet in length used exclusively for Sea Explorer activities. However, to ensure maximum safety, it was BSA policy that all Sea Explorer vessels over 65 feet possess a valid COI when carrying more than six persons in addition to the crew. Therefore, Sea Explorer vessels over 65 feet in length are now required to be inspected and certificated (46 U.S.C. 3301). The section of the 1 October 1979 agreement with BSA that deals with these vessels will be revised to reflect that change.
- b. Vessels inspected under agreement. Sea Explorer vessels of more than 100 GT are not required to be inspected under 46 U.S.C. 3301 et seq., because they do not meet the definition of passenger vessels. Sea Explorer vessels are inspected and certificated in accordance with the existing agreement with BSA. Such vessels may be inspected under the 46 CFR Subchapter T standards. When these standards are inadequate, the provisions of 46 CFR Subchapters F (Marine Engineering), H (Passenger Vessels), and J (Electrical Engineering) may be used.

**NOTE:** Seagoing motor vessels over 300 GT operated by the Sea Explorers are required to be inspected under 46 U.S.C. 3301 et seq.

## SECTION B: DOMESTIC INSPECTION PROGRAMS

**CHAPTER 4: INSPECTION PROCEDURES APPLICABLE TO VESSEL TYPES, CLASSES, AND CATEGORIES**

- c. Uninspected Sea Explorer vessels. Sea Explorers engaged in the rowing of pulling boats are not considered passengers. Therefore, pulling boats are not required to be inspected for certification.
- (1) Likewise, boats of less than 100 GT carrying six or fewer Sea Explorers (in addition to the crew) do not require certification.
  - (2) All Sea Explorer vessels not inspected under 46 CFR Subchapter T must comply with the appropriate requirements of 46 CFR Subchapter C (Uninspected Vessels).
  - (3) Annual application for a Coast Guard Auxiliary Courtesy Motorboat Examination is encouraged.
- d. Manning. Certificated Sea Explorer vessels, whether sail or machinery propelled, must not be operated without the minimum manning specified on the COI.
- (1) The OCMI certificating the vessel must determine minimum manning requirements.
  - (2) The OCMI may tailor license examinations to cover minimum professional requirements only. The OCMI may restrict the licensee to a particular vessel or may permit Sea Explorers to be carried as crewmembers (deckhands) aboard any Sea Explorer vessel.
  - (3) The OCMI must consider the number of passengers carried, route, and general arrangement, in addition to the size of the vessel. The following guidelines are minimum requirements:

Vessel Type and Size	Required Manning
Sailing vessels < 26 feet	1 operator, 2 deckhands
Sailing vessels ≥26 feet	1 operator, 4 deckhands
Power vessels < 26 feet	1 operator, 1 deckhand
Power vessels ≥ 26 feet and larger	1 operator, 2 deckhands

**NOTE:** When a vessel is cruising for more than 12 hours of continuous operation, the preceding minimum crew guidelines must be doubled to provide two separate watches. Powered vessels without engine controls at the steering station require at least one additional crewmember to provide engine control.

---

### 3. Special Situations

46 CFR 175.540 provides that the OCMI may consider departures from specific requirements when special circumstances or arrangements so warrant.

---

### 4. Right to Appeal

46 CFR 1.03-20 provides for appeal of decisions or actions of the OCMI. In addition, district commanders may arrange for a method of informal dispute settlement for minor disagreements.

---

### 5. Assistance from Coast Guard Marine Inspectors

When vessels will be acquired for Sea Explorer use, a marine inspector from the appropriate marine safety unit should be invited by the National Sea Exploring Committee or the BSA regional office or local council to assist in the examination of the vessel. The inspector will be able to affirm the vessel's general suitability for the Sea Explorer program and indicate the requirements it must meet for certification.

---

**SECTION B: DOMESTIC INSPECTION PROGRAMS****CHAPTER 4: INSPECTION PROCEDURES APPLICABLE TO VESSEL TYPES, CLASSES, AND CATEGORIES****6. Establishment of Agreements and Liaison**

The BSA administrator of this agreement is the Director, National Sea Exploring Committee. All matters of national scope between the Coast Guard and Sea Explorers are resolved between the Commandant (or the Commandant's designee) and the National Sea Exploring Committee (or its designee). Liaison between BSA's regional officials and Coast Guard district commanders for the implementation of this agreement by local councils, chartered organizations, and Sea Explorer leaders is the responsibility of the regional director or the director's designee. Liaison responsibilities include resolution of disputes and recognition of significant local conditions.

---

---

**K. CABLE-LAYING SHIPS**

A cable-laying ship is subject to the requirements of 46 CFR Subchapter I. Regulation 3, Chapter I of SOLAS 74 and the 1978 Protocol to the convention do not refer to cable-laying ships or similar types concerning exemptions from SOLAS requirements. Therefore, such vessels, when documented, are subject to SOLAS 74/78 even though they cannot be categorized strictly as either passenger or cargo vessels. The Commandant will require the minimum arrangements that, considering the particular vessel's service and safety elements inherent in its design and construction, can be considered equivalent to the requirements of SOLAS 74/78. Suitable notice of equivalency must be given as provided by Regulation 5, Chapter I of SOLAS 74/78.

---

---

**L. ELEVATOR VESSELS**

The term elevator vessel, as used in 46 CFR 146.02-2(f)(5), means a harbor service vessel that services cargo vessels by loading and offloading bulk cargo, such as grain and ores, by means of elevator buckets. This type of vessel is classed with cable vessels, dredges, fireboats, icebreakers, pile drivers, pilot boats, and welding vessels (none of which carries freight for hire as a cargo ship) as miscellaneous vessels inspected and certificated under 46 CFR Subchapter I.

---

---

**M. RECREATIONAL BOATS RENTED FROM LIVERIES**

It is common for liveries to rent recreational boats, including those propelled by outboard motors, to persons unfamiliar with Federal safety requirements. In some cases, when a deposit is required by the livery for the return of lifesaving or other safety equipment, renters decline to accept the equipment and take the boats without it. As a result, everyone aboard is deprived of the protection such equipment provides. Under 46 U.S.C. 4311, responsibility is placed solely on the operator of a recreational vessel to ensure that the proper safety equipment is aboard.

Livery operators should advise their customers that failure to have the required equipment aboard a recreational vessel places the boat operator in violation of 33 CFR Part 175. Operators should be encouraged to have the proper safety equipment on board.

---

---

## **N. APPROVAL PROCEDURES FOR SPECIAL-TYPE CRAFT OR UNUSUAL DESIGNS**

---

### **1. Introduction**

The Coast Guard is occasionally requested to certificate vessels of unusual design, such as catamarans, hydrofoil surface effect ships, etc., or traditional types (such as sailing vessels and sailing auxiliaries) that incorporate innovative features requiring detailed evaluation. Such vessels may be referred to as “special-type craft.”

Experience in the operation of such craft may be very limited or totally lacking. Current regulations are based upon experiences with conventional craft, and may be unreasonable or inadequate when applied to unique or unusual designs; available engineering data may also have limited applicability. For these reasons, such craft should be certificated only upon careful evaluation of the proposed design(s) or feature(s).

---

### **2. Administration of Requests**

When a request is received for certification of a special-type craft or an unusual design, pertinent plans, specifications, and design calculations must be forwarded to the MSC for evaluation and approval. Elements considered by the MSC to be beyond its capabilities or expertise, or which require important policy decisions, must be forwarded to Commandant (CG-CVC) for evaluation and approval. In any case, the overall degree of safety must not be less than the minimum attained by requirements applicable to conventional craft.

---

---

## **O. INTEGRATED TUG BARGES (ITBS)**

See NVIC 2-81, "Coast Guard Guidance Regarding Integrated Tug Barge Combinations," and its Change-1.

---

---

**SECTION B: DOMESTIC INSPECTION PROGRAMS****CHAPTER 4: INSPECTION PROCEDURES APPLICABLE TO VESSEL TYPES, CLASSES, AND CATEGORIES****P. OIL RECOVERY VESSELS**

---

**1. Introduction**

Vessels built for the purpose of cleaning up spilled oil are of special interest to the Coast Guard. The building and deployment of these vessels should be encouraged. Oil recovery vessels present unique problems from a regulatory standpoint. Such vessels must be able to operate safely in areas where flammable vapors are present. They are designed to carry various grades of oil (usually mixed with water) as cargo for short periods of time, often in a potentially hazardous environment.

Oil recovery vessels are generally small vessels with minimal crews who may be required to operate far from port under poor weather conditions. The primary safety concern for oil recovery vessels is avoiding the ignition of flammable vapors from oil spilled on the water and collected oil stored aboard. The hazard from oil on the water surface may be mitigated by weather conditions and elapsed time prior to cleanup. Likewise, collected oil is usually mixed with water, posing a lesser vapor hazard than oil alone.

In short, the hazard from vapor ignition is variable and difficult to ascertain. One design approach is to require the vessel to have no ignition sources for operation in a hazardous environment. Practically, however, it is extremely difficult to construct and maintain a vessel totally void of ignition sources. These vessels should be considered to have potential ignition sources and should require the same operational restrictions as other vessels in spill areas.

---

**2. Inspection Criteria**

The following criteria must be applied to oil recovery vessels in plan review and certification:

- a. A vessel with no onboard oil-holding capacity must only be inspected under 46 CFR Subchapter I if the gross tonnage or the means of propulsion so require. Otherwise, the vessel must be uninspected.
- b. A vessel with an oil-holding capacity of less than or equal to 20 percent of the deadweight tonnage must be inspected under 46 CFR Subchapter I. Such amounts of oil must be considered as "limited quantities" under 46 CFR 30.01-5 and 90.05-35.
- c. A vessel with a holding capacity greater than 20 percent of the deadweight tonnage must be inspected under 46 CFR Subchapter D (Tank Vessels).
- d. When holding recovered oil, a vessel certificated under 46 CFR Subchapter I must meet the requirements of 46 CFR Subchapter D.

- e. Enclosed machinery spaces must be provided with positive ventilation.

**NOTE:** For vessels under 100 GT, it may be appropriate to apply specific requirements of 46 CFR Subchapter T in lieu of comparable requirements under 46 CFR Subchapter F or J. Such application must be done on a case-by-case basis by the OCMI, depending upon the design specifics of the vessel.

---

### 3. Hazardous Location Equipment

The following comments regarding "hazardous location equipment" apply:

- a. Electrical equipment installations should be kept to a minimum. Hydraulically-powered equipment should be used when available (e.g., hydraulically-powered cargo pumps).
- b. Where electrical equipment is employed (switches, lights, solenoid valves, etc.), it must be one of the following types:
  - (1) Spark ignitionproof (Underwriters Laboratories, Inc. (UL) 1500).
  - (2) Explosion-proof (various).
  - (3) Intrinsically safe (UL 913).

**NOTE:** The UL listing spark ignitionproof (UL 1500) employs a standard that is based on part of the explosion-proof test. Those electrical devices that do not create sparks in normal operation (lights, solenoids, etc.) are inherently spark ignition proof and should obtain UL listing.

- c. Enclosed machinery spaces must be ventilated at a rate of at least 20 changes of air per hour by fans designated as nonsparking under the provisions of either 46 CFR 110.15-1(b)(16) or Subparagraph K.3.b above.
- d. Belt drives must use conducting belts, pulleys, and shafts to prevent the buildup of static electrical charges.
- e. Machinery exhausts must be fitted with spark arrestors.
- f. All exposed surfaces (machinery, light lenses, etc.) must be maintained at a temperature below 400°F. When these surfaces are normally accessible to personnel they must be maintained below 150°F for personnel protection.



**SECTION B: DOMESTIC INSPECTION PROGRAMS****CHAPTER 4: INSPECTION PROCEDURES APPLICABLE TO VESSEL TYPES, CLASSES, AND CATEGORIES**

- g. Oil tank vents must be fitted with flame screens and must have a cross sectional area at least as large as the fill lines.

**NOTE:** Most oil recovery vessels are designed for use with Grades D and E liquids. If use with more flammable grades or with hazardous chemicals is desired, Commandant (CG-ENG) should be consulted. Vessels engaged in other service when not operating as oil recovery vessels must meet normal requirements for that service.

**4. Endorsements on the COI**

An oil recovery vessel's COI must state it is an oil recovery vessel. The endorsement for route should be as broad as possible, consistent with the considerations of seaworthiness. Oil recovery vessels may be expected to respond to pollution incidents at great distances from their home ports, often in open sea conditions. When engaged in recovery operations, they are normally in close proximity to other vessels, and a restricted route would be neither desirable nor necessary.

The COI will normally be endorsed for the recovery of a specific grade of oil, as is done with tank vessels. However, oil that is of a higher grade may have the reduced ignition potential of a lower grade after weathering. Therefore, the COI should include a statement such as, "Approved for the recovery of Grade and lower. Higher grades may be recovered, on a case-by-case basis, as determined by the OCMI/COTP after consideration of the special circumstances of each recovery operation." Such factors as temperature, wind velocity, and time since spillage must be considered in permitting the recovery of higher grades of oil.

---

**Q. SMALL MECHANICALLY FASTENED SHALLOW WATER OIL SPILL RESPONSE VESSELS (OSRVs)**

---

**1. Introduction**

A national response organization, the Marine Spill Response Corporation (MSRC) has developed and constructed small OSRVs for use in shallow water oil spill responses. These OSRVs are unique in that they are normally stored on land, capable of being trailered, launched, and outfitted at a spill site. The launching and outfitting includes joining two barges together to form a single stable OSRV of approximately 25 GT. Commandant (CG-CVC) has conducted conceptual review and the MSC has conducted plan and stability review of these OSRVs. Since the combined tonnage exceeds 15 GT, Commandant (CG-CVC) has determined that these OSRVs are subject to inspection for certification as small recovery vessels.

---

## **2. General Requirements**

MVI Policy Letter No. 03-92 contains the inspection standards identified during the conceptual review for the MSRC OSRVs. Depending on whether the vessel is self-propelled or not, outfitting equipment may include life-saving, fire-fighting, cargo tank-venting, cargo-piping, navigation, bilge pump, propulsion-unit, crane, and hand rail equipment.

These OSRVs are subject to inspection as small recovery vessels, except machinery and electrical may meet the requirements for a skimming vessel. The bilge pump and fire fighting equipment may be portable (barge), or semi-portable (self-propelled).

Toilets and wash basins are not required, as long as a tending vessel provides this service. The MSRC OSRVs are limited to operations not more than 1 mile from land due to the structural integrity of the connection devices.

---

## **3. Inspection**

OCMIs should satisfy themselves that MSRC OSRVs are fit for their intended service. These OSRVs are stored in groups of eight barges. Recognizing that the individual barges are interchangeable provides merit to not requiring all of the barges to be completely outfitted, unless differences are noted. As a minimum, the self-propelled unit should be outfitted and demonstrated. Required equipment and paperwork for all of the barges should be examined/inspected. MSRC has provided stenciled equipment boxes for self-propelled and non-self-propelled configurations, which will facilitate the inventory of the equipment. The amount of equipment provided should match the intended number and type of vessels. Since the barge sections are interchangeable, the lifesaving equipment may be stenciled in a generic fashion, to show it belongs to the group of vessels.

---

## **4. COI Endorsement**

Figure B4-Q-1 below is offered as a standard COI endorsement for the MSRC shallow water OSRVs. The endorsements below are specific to the MSRC OSRVs. These endorsements serve as an example for other small, shallow water OSRVs that may operate in a similar fashion; however, endorsements must be modified based on each specific vessel/operation.

---

## SECTION B: DOMESTIC INSPECTION PROGRAMS

**CHAPTER 4: INSPECTION PROCEDURES APPLICABLE TO VESSEL TYPES,  
CLASSES, AND CATEGORIES**

**Figure B4.Q-1.**

COASTWISE: NOT MORE THAN ONE (1) MILE FROM LAND  
 AUTHORIZED TO CARRY RECOVERED OILS OF GRADE "B" WITH A SPECIFIC GRAVITY OF 1.05 OR LOWER. THE MAXIMUM DRAFT IS 2 FEET 10 INCHES. VESSEL MAY NOT OPERATE IN A HAZARDOUS ATMOSPHERE. CONTINUOUS MONITORING MUST BE EMPLOYED ON MANNED VESSELS WHEN RESPONDING TO OIL SPILLS OF GRADE "B" & "C."

ONE (1) CERTIFIED TANKERMAN SHALL BE PROVIDED DURING ALL CARGO TRANSFER OPERATIONS.

PRIOR TO OPERATION AS AN OIL SPILL RECOVERY BARGE:

1. MUST BE OPERATED WHILE MECHANICALLY FASTENED TO A SINGLE VESSEL OF THE SAME DESIGN AND CONSTRUCTION.
2. PRESSURE-VACUUM VALVES AND RECOVERED OIL PIPING AND VALVES MUST BE INSTALLED.
3. CLEATS AND DECK FITTINGS MUST BE INSTALLED.
4. NAVIGATION LIGHTS MUST BE INSTALLED.
5. DURING ALL MANNED CARGO OPERATIONS, THE BARGE SHALL BE EQUIPPED WITH HAND RAILS, ONE RING BOUY WITH LIGHT AND LINE, ONE TYPE I PFD FOR EACH PERSON ON BOARD, A PORTABLE BILGE PUMP WITH SUITABLE SUCTION AND DISCHARGE HOSE AND TWO B-II PORTABLE FIRE EXTINGUISHERS MUST BE INSTALLED.

PRIOR TO OPERATION AS A SELF-PROPELLED VESSEL, THE FOLLOWING ADDITIONAL ITEMS MUST BE PROVIDED:

1. ONE PORTABLE COMBUSTIBLE GAS METER FOR MONITORING ATMOSPHERE OR TANK VAPOR CONCENTRATIONS.
2. IN LIEU OF TWO B-II PORTABLE FIRE EXTINGUISHERS; ONE B-V SEMI-PORTABLE AND ONE B-II PORTABLE FIRE EXTINGUISHER SHALL BE PROVIDED.
3. WHEN MANNED A SUITABLE TENDING VESSEL WITH ADEQUATE SANITARY FACILITIES MUST BE PROVIDED.
4. THE MAXIMUM DRAFT IS 2 FEET 8 INCHES WHEN OPERATING IN THE SELF-PROPELLED MODE.
5. THE CRANE IS TO BE OPERATED IN ACCORDANCE WITH THE CAPACITY CHARTS BEARING U.S. COAST GUARD MARINE SAFETY CENTER APPROVAL STAMP DATED 25 JULY 1994.
6. WHEN OPERATING AS A SELF-PROPELLED VESSEL, THE VESSEL MUST BE MANNED WITH ONE MASTER AND A DECKHAND; HOWEVER, WHEN OPERATING OVER 12 HOURS IN ANY 24 HOUR PERIOD AN ALTERNATE CREW MUST BE PROVIDED TO SERVE IN A TWO WATCH ROTATION.

## **5. Manning**

The proposed manning for 12-hour operations of the self-propelled vessel was a licensed master and a deckhand. Due to the relatively small size of these vessels, the master may act as the person-in-charge of transfer while navigating the OSRV, provided the master does not have to participate in manual tasks associated with the transfer. The adequacy of the manning level should be demonstrated during the OSRV's trials and must be sufficient to comply with the work hour limits of 46 U.S.C. 8104 (n). Deviations from the proposed manning level should be forwarded to Commandant (CG-CVC) for final determination.

---

### **R. LANDING CRAFT-TYPE VESSELS**

Landing craft used by the armed services in wartime are obviously designed for special purposes. They are of lighter construction than merchant ships, and the opening-bow design of most types presents structural integrity problems not found on conventional vessels. The Commandant strongly discourages the use of these vessels for commercial service. When landing craft are permitted to be used commercially, special consideration must be given to their suitability for the proposed operation. In some instances, the hull structure has been required to be strengthened before the vessel is certificated.

In all cases in which ex-landing craft have been permitted to carry passengers, and in most cases in which they are permitted to carry cargo, a requirement has been made for the permanent closure of bow doors. For those cargo carriers on which bow doors were retained, indiscriminate beaching has not been permitted and suitable shore facilities must be provided. OCMI's must continue to give particular attention to vessels of landing craft types. The construction, arrangement, equipment, and material condition of each particular vessel must be considered in determining its suitability for the proposed operation. Each new request for inspection of such a vessel must be evaluated on its own merits. Unless covered by the following provisions, each new request should be referred to Commandant (CG-CVC) with appropriate recommendations from the OCMI.

---

#### **1. LSTs**

NVIC 7-56 and NVIC 11-63 contain instructions concerning the structural reinforcement, drydocking, and hull inspection of manned and unmanned LSTs, respectively. Certain additional requirements have been developed since the issuance of these NVICs.

Hull bottom reinforcement, in addition to that shown in Figure 1 of NVIC 7-56, is required to provide at least 14 square inches of additional bottom plating sectional area on each side of the centerline. This may be provided by strapping, or by increasing the width of the 9/16-inch thick strakes at the centerline and in way of the longitudinal bulkheads.

Existing machinery, pressure vessels, piping systems, electrical installations, lifesaving and firefighting equipment, etc., that will not be used must be removed or inactivated. Any

**SECTION B: DOMESTIC INSPECTION PROGRAMS****CHAPTER 4: INSPECTION PROCEDURES APPLICABLE TO VESSEL TYPES, CLASSES, AND CATEGORIES**

original equipment or systems designed for use in the proposed service must comply with the applicable regulations.

Full detail plans of all modifications of the basic LST structure and configuration, including those called for in NVIC 7-56, NVIC 11-63, and this section, must be approved by the MSC before inspection for certification. These plans should be submitted well in advance of anticipated alterations or operations to permit adequate review and lead time for work.

---

**2. Other Types of Craft**

Landing Crafts, Utility (LCUs), Medium (LCMs), and Tank (LCTs) with bow doors in use have been permitted to carry cargo on waters considered to be semi-protected, provided that the following are true:

- a. The OCMI is satisfied as to the material condition of the vessel and its degree of meeting equipment requirements.
- b. Appropriate conditions and limitations, including the qualification of routes to reasonable operating conditions, are stated on the COI.
- c. Provisions are made to waive reporting requirements in instances of routine intentional grounding. The following statement must be entered on the COI of a landing craft: "Notice of casualty in accordance with 46 CFR 4.051(A)(B)(C) shall be made for any accidental stranding or grounding and for any intentional grounding that causes, or is suspected of having caused, damage affecting the seaworthiness of the vessel."

- d. The cargo capacity of such vessels must not exceed that prescribed by the following table:

<b>VESSEL TYPE AND LENGTH</b>	<b>Protected Waters / No Beaching Waters</b>	<b>Semi-Protected Waters / Beaching</b>
LCM (50, 56 ft.)	30 Tons (Short)	20 Tons
LCT (117, 120 ft.) 150 Tons	100 Tons	

- e. Cargo must be loaded low in the vessel, well within the side walls, and properly lashed and stowed. The use of cranes on board these vessels should not be permitted without stability calculations being submitted.
- f. Bow and stern sections of LCTs must be welded to center sections.

### **3. DUKWs**

These World War II-vintage amphibious craft are equipped with radiator-cooled engines. Departures from 46 CFR 182.420 (which prohibits radiator-cooled engines in vessels) are authorized due to the DUKWs unique arrangement, provided a temperature indicator and an alarm are installed (see Paragraph B.2.j above).

## **S. YACHTS**

### **1. Application of Inspection Laws**

Although normally operated as recreational vessels, yachts may be subject to inspection as seagoing motor or steam vessels, depending on the vessel size and area of operation.

### **2. Steam- Propelled Yachts**

A "steam vessel" is defined under 46 U.S.C. 2101(37). Steam vessels are subject to inspection under 46 U.S.C. 3301. Steam-propelled yachts (recreational vessels) more than 65 feet overall in length are subject to inspection. Steam-propelled yachts more than 40 feet in length, but not more than 65 feet overall in length, only require inspection with respect to their boiler, engine, and other operating machinery, per 46 U.S.C. 3302(k).

### **3. Motor- Propelled Yachts**

**SECTION B: DOMESTIC INSPECTION PROGRAMS****CHAPTER 4: INSPECTION PROCEDURES APPLICABLE TO VESSEL TYPES, CLASSES, AND CATEGORIES**

Motor-propelled yachts of at least 300 GT making voyages beyond the boundary line defined in 46 CFR Part 7 are, by definition, "seagoing motor vessels" subject to inspection under 46 U.S.C. 3301. Such vessels must be inspected under 46 CFR Subchapter I.

---

**4. Manning Requirements**

See MSM Volume III, Marine Industry Personnel, COMDTINST M16000.8B (Series).

---

---

**T. FISHING AND FISHERY-RELATED VESSELS**

---

**1. Introduction**

Fishing vessels, fish processing vessels, and fish tender vessels, as defined in 46 U.S.C. 2101(11)(a), (b), and (c), respectively, may be exempt from vessel inspection requirements and most manning standards by specific wording in 46 U.S.C. 3302(b), (c)(1) and (2), 3304(d), and 3702(c) and (d). Basically, size, propulsion, and service or use of a vessel determines whether or not it is subject to inspection and manning regulations.

---

**2. Determination of Exemptions**

Determining the applicability of exemptions from the various standards to all the different vessel types, fisheries, and locations can be difficult. Figure 10-3 provides a summary of the different requirements. This is intended to assist in decision making and is not necessarily all-inclusive. Questions should be directed to the District Commander (m) or Commandant (CG-CVC). For uninspected vessels to which manning standards apply, reasonable attempts should be made to verify compliance. Boardings of opportunity in conjunction with casualty and pollution investigations, Enforcement of Laws and Treaties (ELT) and Search and Rescue (SAR) assistance cases, etc., can be used to this end.

---

### **3. Reporting Requirements**

Since the need for these vessel-specific exemptions and their impact on safety is periodically reviewed by the Congress, it is important that the Commandant has accurate information on the casualty records of exempted vessels. Whenever possible, casualty investigation reports should identify vessels known to be within these exemption categories. Likewise, any information obtained locally that is relevant to this issue should be forwarded to Commandant (CG-CVC).

---

### **4. Safety and Lifesaving Equipment on Fishing Vessels**

All safety and lifesaving equipment in excess of that required by 46 CFR Part 28, whether an approved type or not, carried onboard any commercial fishing industry vessel must be--

- a. Maintained and inspected as required by regulation and in compliance with the manufacturer's guidelines;
- b. Distinctly and permanently marked as to be used only for training if it does not meet the maintenance and inspection standards; or
- c. Removed from the vessel if it does not meet the maintenance and inspection standards.

**NOTE:** All excess safety or lifesaving equipment retained onboard a vessel for training purposes must be stowed in such a manner or location so that it will not be mistakenly used during an actual emergency.

---

### **5. Notes on the Statutes and Regulations Pertaining to Fishing and Fishery- Related Vessels**

- a. Fishing vessels, tenders, and processors exempted from inspection by 46 U.S.C. 3302 are not exempt from all manning requirements. See 46 U.S.C. 8103, 8104, 8301, 8701, and 8702. If the vessel has a COI, 46 U.S.C. 8101 applies. The implementing regulations are in 46 CFR Part 15.
- b. The Officers' Competency Certificates Convention, 1936, is implemented by 46 U.S.C. 8304, and applies to vessels in this category that are of 200 or more GT. The implementing regulations are in 46 CFR 15
- c. Fishing and fishery-related vessels of 100 GT or less are subject to 46 U.S.C. 8901. The implementing regulations are contained in 46 CFR Subchapter T.
- d. Fishing and fishery-related vessels constructed before 1 January 1980, and vessels aboard which conversion for such use was begun before 1 January 1980 (and



**SECTION B: DOMESTIC INSPECTION PROGRAMS****CHAPTER 4: INSPECTION PROCEDURES APPLICABLE TO VESSEL TYPES, CLASSES, AND CATEGORIES**

completed prior to 1 January 1983) are not required to have a coastwise load line assigned. See 46 U.S.C. Chapters 51 and 141.

- e. Fishing and fishery-related vessels constructed before 15 August 1974 or converted for such use before 1 January 1983 are not required to have a coastwise load line assigned. See 46 U.S.C. Chapters 51 and 141.
- f. Fishing and fishery-related vessels engaged in foreign voyages or international voyages that are "new vessels" 79 or more feet in length, or "existing vessels" of 150 or more GT, are required to have a load line. See 46 U.S.C. Chapters 51 and 141.
- g. Fishing and fish tender vessels of not more than 500 GT engaged in only the fishing industry are exempt from the requirements of 46 U.S.C. Chapter 37.

---

**U. RIVER-RUNNING VESSELS**

---

**1. Introduction**

The 1970s saw a tremendous national upsurge in commercial river-running activities, commonly referred to as white water rafting. This involves non-self-propelled boats (usually inflatable rafts), floating down streams marked by rapids of varying degrees of difficulty. These expeditions may last from several hours to several days. Expeditions on relatively calm waters offer novice adventurers the enjoyment of a wilderness journey, while rougher waters offer the thrill of "shooting the rapids." As some river-running operations carry passengers for hire on navigable waters of the United States, they fall within the purview of 46 U.S.C. Chapters 33, 41, or 42 and, consequently, the regulations in 46 CFR Subchapters C and T. As these regulations do not directly address river-running operations, a project was initiated to develop suitable regulations and a program for inspection and licensing.

**NOTE:** The only requirements that apply specifically to white water activities are: have Type I or Type V (Special Purpose) personal flotation devices for each person aboard, and conduct safety orientation for passengers.

## **2. Program Evaluation**

After considerable study, the Coast Guard determined that a new regulatory program was unnecessary and inappropriate. White water rafting is generally a thrill-type, inherently risky activity in which participants willingly seek an exciting adventure. Nevertheless, the industry has a good safety record, attributable in part to regulation by Federal and state agencies (U.S. Department of the Interior, state boating safety administrators, etc.) and the guidance of rafting owner/operator trade associations. The occasional accidents that occur are not likely to be prevented by a Coast Guard inspection program. Further, because of the distances from most marine safety units to "wild river" areas, the Coast Guard would incur large increases in operating costs with little tangible improvement in safety. Therefore, inspection and licensing action will not be undertaken for commercial white water activities. Future efforts regarding these activities will be initiated to encourage the states (and, on Federally-owned lands, cognizant Federal agencies) to oversee white water activities.

---

## **3. Discretion of OCMIs**

This policy does not abrogate Coast Guard authority over white water rafting. The OCMI should be aware of such activities in his or her zone, and should exercise jurisdiction if a specific problem demands corrective action at the local level. Inspection and licensing efforts should not be initiated without prior approval of Commandant (CG-CVC). Casualties involving loss of life should be investigated with possible recourse to civil penalty proceedings for negligent operation under 46 U.S.C. 2302.

---

---

# **V. OCEAN INCINERATION VESSELS**

---

## **1. Introduction**

With the advent of stricter environmental controls on the disposal of hazardous wastes, ocean incineration has become a topic of greatly increased interest. This, like land-based incineration, is a high-temperature combustion process; however, it is performed on special-purpose vessels. Wastes disposed of in this manner are organic compounds, usually chlorinated hydrocarbon wastes, that are difficult to destroy by other processes and that produce highly acidic combustive wastes. The burning process itself is conducted at specific ocean sites that have been designated by the Environmental Protection Agency (EPA). One site is presently located in the Gulf of Mexico; another has been proposed in the Atlantic Ocean. United States involvement in the ocean incineration concept began in the early 1970s, when the Singapore-registered vessel VULCANUS (renamed VULCANUS I) was employed to dispose of chlorinated hydrocarbon wastes for the Shell Oil Company. Since that time, VULCANUS I and now VULCANUS II have burned Polychlorinated Biphenyls (PCBs) and the herbicide 2,4,5-T ("Agent Orange").

---

**SECTION B: DOMESTIC INSPECTION PROGRAMS****CHAPTER 4: INSPECTION PROCEDURES APPLICABLE TO VESSEL TYPES, CLASSES, AND CATEGORIES****2. Federal Controls**

The EPA and the Maritime Administration (MARAD) established an interagency working group in which the Coast Guard participated. This group considered the environmental impacts of the ocean incineration process, its economic feasibility, possible government actions to encourage development of a U.S. incineration fleet, and presently applicable regulations. This group determined that the only government support for such development existed in MARAD construction loan guarantees. The EPA is responsible for incinerator efficiency, designations of burning sites, and enforcement of waste disposal requirements. The Coast Guard is responsible for approving the designs of such vessels, ensuring that they are maintained to acceptable standards, overseeing loading operations, and assisting the EPA in enforcement activities.

**3. Coast Guard Enforcement Measures**

A rider to the Fisheries Act Amendments of 1982, which became effective on 29 December 1982, places U.S. incineration activities under the protection of the Jones Act and restricts burning of U.S. wastes to U.S. vessels. Special exemptions have been given to the VULCANUS I and VULCANUS II; the latter, under Liberian registry, will operate principally from Mobile, Alabama. However, these vessels operate under COIs and are subject to drydock examinations and inspections to ensure their maintenance to the same standards as U.S. incinerator vessels. Coast Guard COTP personnel also monitor loading operations and assist in enforcement activities. Special inspection procedures may be required to ensure adequate protection for Coast Guard personnel. Commandant (CG-CVC) will provide specific guidance when the VULCANUS I and VULCANUS II are due to be inspected.

**W. LAUNCHES AND LIFEBOAT USES****1. Passenger Vessels—Launches**

Foreign flag vessels occasionally use their own launches or lifeboats to ferry passengers ashore. Such use of ship's boats to ferry passengers between a passenger vessel and shore constitutes the carriage of passengers for hire. Operations and manning, including licensed operators, must be in accordance with the regulations for passenger vessels.

Some foreign flag states issue Lifeboat/Tender Safety Equipment Certificates to lifeboats used as passenger launches. Although these are not SOLAS certificates, they certify that the boat meets an equivalent level of safety in view of its limited route and service. These launch

certificates are considered COIs issued by the flag state (see 46 U.S.C. 3303). Foreign flag launches with SOLAS Passenger Ship Safety Certificates or unexpired certificates of inspection issued by proper authority of its respective country are subject to Control Verification procedures. Launches without SOLAS certificates or unexpired certificates of inspection are subject to U.S. inspection and certification.

- a. For foreign flag launches, a U.S.-issued COI should include appropriate limitations on the area of operation. In no case should the COI on a foreign flag launch authorize operation in areas outside of U.S. jurisdiction. At a minimum, the inspection should be sufficient to ensure that machinery and electrical installations are safe and appropriate and that lifesaving equipment adequate for the area of operation is provided. Drydock inspections can be completed with the boat in the davits.
  - b. For foreign launches, including foreign-built boats on U.S. registered vessels, the U.S. Customs Service has ruled that transport of passengers between a passenger vessel in U.S. territorial waters and a point on shore is not a violation of 46 App. U.S.C. 289, if the following conditions are met:
    - (1) The transporting boats arrive in the U.S. territorial waters on board the vessel.
    - (2) The boats are used solely to transport the passengers between the vessel and the shore.
    - (3) The District Director of Customs is satisfied that it is not safe or feasible for the vessel to berth at a pier.
    - (4) The boats depart U.S. territorial waters on board the vessel.
  - c. Foreign-built launches that meet the conditions of the Customs Service ruling would not be engaged in coastwise trade. The boats would, therefore, not have to be documented, even if carried on a U.S.-registered vessel. Depending upon state law, these boats might have to be numbered in the state of principal use, if they are not documented.
-

**SECTION B: DOMESTIC INSPECTION PROGRAMS****CHAPTER 4: INSPECTION PROCEDURES APPLICABLE TO VESSEL TYPES, CLASSES, AND CATEGORIES****2. Passenger Vessels—Use of Lifeboats as Launches**

All of the conditions for launches apply to lifeboats used as launches. In addition, such boats must meet all requirements for lifeboats. The boats may be used as passenger launches in and around the port in the vicinity of the vessel as long as the vessel is at anchor or at the dock. (However, note that most operations in U.S. waters with the vessel at the dock would constitute coastwise trade with attendant documentation issues.) When the vessel is at anchor, there must be enough lifeboats and davit-launched liferafts remaining on board or alongside to accommodate all persons remaining on board the vessel. The boats will be limited to launch service between the vessel and the shore at all times when there are passengers on the vessel.

- a. For vessels with Coast Guard-approved lifeboats, certification for the boats should not prove difficult, since the construction regulations for lifeboats have many similarities to 46 CFR Subchapter T requirements, such as fire-retardant resins for Fiber-Reinforced Plastic (FRP) construction, fuel and electrical system installation, and others.
  - b. It is possible that the number of persons permitted on board the boats in launch service will be different from the lifeboat capacity due to differing freeboard and stability requirements and methods of determining capacity.
  - c. SOLAS Regulation III/19.2 (1983 SOLAS Amendments) states "Before the ship leaves port and at all times during the voyage, all lifesaving appliances shall be in working order and ready for immediate use." U.S. regulations for large passenger vessels require that the lifeboats and liferafts "be kept in good working order and available for immediate use at all times when the vessel is being navigated and, insofar as reasonable and practicable, while the vessel is not being navigated" (46 CFR 176.808). This means that the boats must be stowed and configured for immediate use as lifeboats when the vessel is underway, including removal of floorboards and any other extra equipment carried for launch use which might interfere with use as a lifeboat.
  - d. Requirements for buoyant apparatus or life floats can normally be waived for lifeboats used as launches, since lifeboats are equipped with lifelines and inherent flotation that prevent sinking. Lifejackets and ring life buoys of the appropriate number are required when the lifeboat is being used as a launch.
-

### 3. Cargo and Tank Vessel Launches

The situation for cargo and tank vessels is somewhat different. In some cases, these vessels are required to anchor offshore while awaiting cargo, berthing, stores, etc. The use of the ship's boats for transport of crew and stores between the vessel and the shore is acceptable. However, operation to or between different points on shore or to other vessels could constitute coastwise trade, and therefore involve issues of licensing and documentation.

---

---

## X. SUBMERSIBLE VESSELS

A submersible vessel or "submersible" is a privately owned vessel capable of completely submerging that is designed for manned or unmanned independent operations underwater. Voluntary reports of submersible operations in or near U.S. waters may be made to the nearest Coast Guard Operations Center. Inquiries about the extent of such reports and other questions that cannot be resolved locally should be directed to Commandant (CG-CVC) at (202) 372-2075. These reports are intended primarily for informative use in SAR activities only.

---

### 1. Regulatory Oversight

- a. General requirements. Presently, the Coast Guard does not have inspection standards applicable to the design or construction of submersible vessels. As a submersible's size, means of propulsion, nature of operation, and cargo carried (if any) approximates those on surface vessels, as regulated under Title 46, CFR, the appropriate standards will be applied to ensure a degree of safety equivalent to that obtained on surface vessels. For further information, refer to [NVIC 5-93](#).
- b. Application of 46 CFR Subchapter C. Generally, submersibles are subject to 46 CFR Subchapter C (Uninspected Vessels) requirements for lifesaving and firefighting equipment, display of navigation lights and use of signals, and control of hazards associated with gasoline engines. Some items covered in 46 CFR Subchapter C may not be applicable for use on small submersibles. Owners or operators of such craft may request the OCMI to accept equivalent equipment under 46 CFR 24.15.
- c. Application of 33 CFR Subchapter S. Submersibles must also comply with certain provisions of 33 CFR Subchapter S (Boating Safety).
  - (1) Undocumented submersibles (i.e., those without Federal documentation or license) with propulsion equipment must be numbered in accordance with the Federal numbering system or the numbering system of the state in which the submersible will principally operate.
  - (2) When a submersible is involved in a collision, accident, or casualty, the operator must report such occurrences to the appropriate OCMI or state authorities, and render all possible assistance to others involved in such incidents.

**SECTION B: DOMESTIC INSPECTION PROGRAMS****CHAPTER 4: INSPECTION PROCEDURES APPLICABLE TO VESSEL TYPES, CLASSES, AND CATEGORIES**

- (3) 33 CFR Part 155 (Oil or Hazardous Material Pollution Prevention Regulations for Vessels) and 33 CFR Part 159 (Marine Sanitation Devices) also apply to submersibles.
- 

**2. Recreational Submersibles and Those Carrying Six or Fewer Passengers**

These vessels are included within the meaning of the term "recreational vessel" in 46 U.S.C. 2101(25) and "uninspected passenger vessel" in 46 U.S.C. 2101(42). Accordingly, operators of such vessels are subject to the requirements of 46 U.S.C. Chapter 43 and 33 CFR Subchapter S, as well as the regulations indicated above. Recreational submersibles and those carrying six or fewer passengers are therefore subject to the following:

- a. All submersibles carrying six or fewer passengers for hire must be operated by a person licensed by the Coast Guard as an Operator of Uninspected Passenger Vessels.
  - b. 46 U.S.C. 4310 and 33 CFR Part 179 require the manufacturer of a submersible to notify the first purchaser of any defects and to correct them.
  - c. Under 33 CFR Part 181, the manufacturer must affix a Hull Identification Number (HIN) to the submersible. This requirement applies to "backyard builders" as well as industrial firms. Upon written request from a manufacturer (or importer), Commandant (CG-BSX) will assign a Manufacturer Identification Code (MIC) which is a required part of the HIN. Persons who build or import boats for their own use and not for sale must obtain the required HIN from the State Boating Law Administrator of the state where the boat will be principally used, or from the Coast Guard district office in the area.
  - d. In addition, 46 U.S.C. 4302 authorizes the Coast Guard to prescribe safety standards for the design and performance of submersibles. These are published in 33 CFR Subchapter S. Prospective manufacturers of submersibles should be encouraged to contact the Auxiliary, Boating and Consumer Affairs Division, Commandant (CG-BSX), to determine which 33 CFR Subchapter S requirements will apply to their craft.
-

## **Y. PASSENGER CARRYING VESSELS**

---

### **1. Passenger Vessels (PVs)**

46 U.S.C. 2101(22) defines a PV as a vessel of at least 100 GT carrying more than 12 passengers, including at least one passenger for hire or a vessel that is chartered and carrying more than 12 passengers. Employees of the owner of a PV who are on board and not engaged in the business of the vessel are passengers.

---

### **2. Uninspected Passenger Vessels (UPVs) and Small Passenger Vessels (SPVs)**

The statutory definitions for UPVs and SPVs do not contain the “for hire” requirement.

The definition of passenger is the test for whether compliance with the vessel inspection and manning regulations is required. When employees are on board an employer’s PV or UPV, they are passengers by definition unless they are the master or a crewmember engaged in the business of the “vessel.” An example of this might be a boat owned by a boating magazine covering an event on the water. The master and crew of the vessel would not be considered passengers for either a UPV or SPV. However, a company advertising salesman on board a UPV to take notes on prospective clients would not be considered crew engaged in direct business of the vessel and would be a passenger. With an SPV, this same salesman is engaged in the business of the vessel owner and, by extension, is not a passenger. If the vessel in question is operated on a legal bareboat charter and is carrying only employees who are not considered passengers under 46 U.S.C. 2101(21), then they are not engaged in coastwise trade and documentation is not required.

---

### **3. Passenger Vessel Investigations**

Pending definitive legislative resolution, enforcement personnel must continue investigations and boardings of passenger vessels as current procedures specify (except in situations where more specific guidance pertaining to particular vessels dictates otherwise). Any vessel documents and charter agreements that appear to be in proper order when reviewed during boardings should be accepted at face value. The following courses of conduct should be observed in specific situations:

- a. If the condition of the documents and the circumstances of the voyage give the boarding officer no reason to doubt the validity of a purported bareboat charter party, a valid charter agreement shall be assumed to exist. For the purposes of any further safety inspection, the vessel will be considered to be within 46 U.S.C. 41 or 43 as appropriate.
- b. If a bareboat charter party appears to be valid, but the circumstances nevertheless



USCG Marine Safety Manual, Vol. II: Materiel Inspection

**SECTION B: DOMESTIC INSPECTION PROGRAMS**

**CHAPTER 4: INSPECTION PROCEDURES APPLICABLE TO VESSEL TYPES,  
CLASSES, AND CATEGORIES**

give

## SECTION B: DOMESTIC INSPECTION PROGRAMS

**CHAPTER 4: INSPECTION PROCEDURES APPLICABLE TO VESSEL TYPES, CLASSES, AND CATEGORIES**

- the boarding officer some reason to doubt its validity, no further immediate inquiry into the nature of the agreement will be undertaken.
- (1) In these circumstances, however, guest lists, pertinent legal documents, and the names and addresses of owners, operators, or persons-in-charge may be gathered during the boarding for later follow-up investigation ashore.
  - (2) Any further safety inspection during the boarding must be conducted in accordance with the assumption that the documents are valid, i.e., the vessel will be considered within 46 U.S.C. 41 or 43, as applicable.
- c. If a purported bareboat charter party is obviously invalid, then the inspection must proceed as if no bareboat charter party exists.
  - d. The voyage of any vessel determined to be unsafe under the assumptions described above should be terminated in accordance with applicable guidelines.

---

**4. Acceptance of the International Code of Safety for High-Speed Craft (HSC code) as equivalent to meeting Title 46, Code of Federal Regulations (CFR), subchapter H or subchapter I**

- a. On January 10, 1996, the Coast Guard published a final rule that amended the small passenger vessel regulations under 46 CFR, Subchapter T and created a new class of small passenger vessel under 46 CFR, Subchapter K. Among the many changes to these regulations, the Coast Guard included a provision that accepts the HSC Code as an equivalent to meeting the requirements of Subchapters T and K. Specifically, under 46 CFR 114.540 (Subchapter K) and 46 CFR 175.540 (Subchapter T): *The Commandant may accept compliance by a high speed craft with the provisions of the International Maritime Organization (IMO) "Code of Safety for High-Speed Craft" as an equivalent to compliance with applicable requirements of this subchapter.* Although this "blanket" equivalency provision exists for small passenger vessels of less than 100 gross tons, no such regulatory provision exists for passenger vessels of 100 gross tons or more, where 46 CFR, Subchapter H would apply. However, under the general equivalency provision of Subchapter H, as given by Subpart 70.15, the Commandant has, on an individual basis, accepted the use of the HSC Code as equivalent to meeting the requirements of Subchapter H. These individual equivalency determinations were based upon the Coast Guard's judgment that the HSC Code provides for a level of safety equivalent to that of Subchapter H.

- b. Although to date the Coast Guard has not received any individual requests to accept the use of the HSC Code as an equivalent to Subchapter I for a high-speed cargo vessel, the same rationale used for accepting its equivalence to Subchapter H should apply. The HSC Code is considered an appropriate standard for regulating the safety of any high-speed craft, regardless of vessel service. In fact, any vessel constructed on or after 1 January 1996 that engages in international voyages and that meets the definition of "high-speed craft", is given the option to comply with the HSC Code in lieu of SOLAS regulations. Since the equivalency provisions of Subchapter I, as given by 46 CFR, Subpart 90.1 5, mirror that of Subchapter H, it is appropriate to extend this blanket equivalency for the HSC Code to Subchapter I vessels as well.
  - c. By announcing the Coast Guard's decision to accept the HSC Code as equivalent to meeting Subchapter H or I, the need for processing a separate equivalency determination for each individual vessel is eliminated. This blanket equivalency will allow the prospective builder and owner/operator of a high-speed craft to design, construct, outfit, and operate a high-speed craft in accordance with the HSC Code in lieu of meeting the requirements of Subchapter H or I. This ruling, however, is contingent upon the HSC Code being applied and complied with in its entirety. Also, it must be clearly understood that this equivalency determination is limited to the commercial vessel safety requirements of 46 CFR, Subchapter H and I. The requirements of other applicable federal regulations, beyond these subchapters, must still be met. This would include the miscellaneous requirements prescribed by 46 CFR, Subchapter A, the manning and licensing requirements of 46 CFR, Subchapter B, and the safety management, pollution prevention, and navigation safety regulations under Title 33 CFR.
  - d. This guidance is limited to high-speed craft that would otherwise be subject to inspection under 46 CFR, Subchapter H or Subchapter I. Specifically, this applies to a high speed passenger vessel of 100 gross tons or more, or a high-speed freight vessel of more than 15 gross tons. Further, for the purposes of this section, the definition of high-speed craft will be identical to that given by the HSC Code, i.e.,: (A *high-speed* craft is a vessel capable of a maximum speed, in meters per second (m/s), equal to or exceeding:  $3.7 \times \nabla$  (to the 0.1667 power); where  $\nabla$  equals displacement corresponding to the design waterline (m<sup>3</sup>)).
  - e. Officers-in-Charge, Marine Inspection (OCMIs) shall accept the use of the HSC Code as an equivalent to meeting Subchapters H or I, subject to the conditions discussed above. When submitting application for inspection or vessel plans to the OCMI or to the Coast Guard Marine Safety Center, vessel representatives should communicate their intention to apply the HSC Code in accordance with the terms under this section.
-

**SECTION B: DOMESTIC INSPECTION PROGRAMS****CHAPTER 4: INSPECTION PROCEDURES APPLICABLE TO VESSEL TYPES,  
CLASSES, AND CATEGORIES****Z. OIL/BULK ORE (OBO) VESSELS**

---

**1. Class Problems**

OBO vessels are vessels that originally carried grain and ore cargoes and were then converted to oil carriers. The handling of grain and ore cargoes requires the use of clamshell buckets and draglines, as well as other types of shovel equipment that is dropped into the cargo holds. The bulk cargo is also moved around inside the holds with overhead unloaders and bulldozers. The use of this heavy machinery to handle these types of cargo causes damage to the cargo hold boundaries. When these vessels enter into the liquid cargo trade, there may be many leaks into the void spaces surrounding the converted cargo tanks. This presents an explosion and fire hazard if the void spaces are not properly cleaned or inerted.

---

**2. Inspection Procedures**

Although OBO vessels identified as having leakage problems are primarily Swedish built, all vessels of this configuration should be considered to have the potential of leakage into void spaces. The following actions should be taken to minimize the potential for leakage risk:

- a. During each required boarding of an OBO carrying flammable or combustible liquid cargoes, and more frequently if deemed appropriate by the OCMI, voids should be sounded for leakage and otherwise checked to ensure that they are clean and free of vapors. If cargo is found in a void space, then that space must either be cleaned and gas-freed or inerted to the satisfaction of the OCMI.
  - b. Some vessels have inerting systems connected to void spaces, which require extra attention. These spaces should be checked for oxygen (O<sub>2</sub>) content. If the O<sub>2</sub> content is above allowable limits, the inerting system should be brought on line and the O<sub>2</sub> level reduced, unless it can be shown that there is no leakage of cargo into the void spaces.
- 

**3. Notification of Cargo Leakage**

When leakage of cargo into a void space is found, the OCMI should take whatever action he or she deems appropriate to ensure that transfer operations can be conducted safely. Notification should be made to the vessel's master and owner or operator that the vessel will not be allowed to return to the United States until all leaks have been repaired. The vessel's classification society should also be notified of the defects. A Special Inspection Note

should be entered into the vessel's MISLE file (see MSM Volume I, Administration and Management, COMDTINST M16000.6 (series), Chapter A3).

---

## **AA. DRACONES**

The Coast Guard has concluded that it would be unrealistic to apply inspection standards to dracones. Dracones are essentially employed as emergency response equipment, much the same as skimmers and containment booms. Although dracones may technically be considered vessels when deployed, their construction, operational limitations, and mode of employment make application of the inspection statutes inappropriate. It is recommended that contractors using dracones for temporary storage or transfer of product periodically examine them in accordance with manufacturer's instructions. Otherwise, there are no applicable servicing or examination criteria.

---

## **BB. UNDOCUMENTED VESSELS**

---

### **1. Authority for Numbering of Undocumented Vessels**

Under 46 U.S.C. 12302, the Secretary of the Department of Transportation (SEC DOT) has the authority to establish a Federal standard vessels numbering system, and to approve state numbering systems which are in accordance with this Federal numbering system. The Federal system is outlined in 33 CFR Part 173; provisions for state number systems are found in 33 CFR Part 174. Most states have met the basic intent of the Federal standard system and their numbering systems have been approved accordingly.

**NOTE:** In 1985, only two jurisdictions lacked numbering systems that complied with the Federal standard: Alaska and New Hampshire. The numbering of all boats registered in these states that operate on waters under the jurisdiction of the United States is accomplished by Marine Safety Office (MSO) Juneau, for Alaska, and the First Coast Guard District (CCGD1), for New Hampshire.

---

### **2. Comparing Federal and State Numbering**

Approved state numbering systems meet the basic intent of the Federal standards under 33 CFR Parts 173 and 174, and they number all undocumented vessels equipped with propulsion machinery of any type. There are slight differences between the standard system and individual state systems. For example, Rhode Island registrations expire every 2 years, instead of the 3 years allowed by the standard system; in other states, the registration expires annually. Approximately one-quarter of the states require numbering of vessels other than those propelled by machinery only. Validation stickers, required for those vessels numbered by the Coast Guard, are optional under state numbering systems.

**SECTION B: DOMESTIC INSPECTION PROGRAMS****CHAPTER 4: INSPECTION PROCEDURES APPLICABLE TO VESSEL TYPES,  
CLASSES, AND CATEGORIES****3. Numbering Undocumented Vessels**

The procedures for Federal and state systems for numbering undocumented vessels are similar. For a new number issue, the vessel owner forwards an Application for a Certificate of Number, plus a registration fee, to the appropriate numbering authority. Upon receipt of the application and fee, the numbering authority will usually issue a temporary Certificate of Number. The permanent certificate and validation decal(s), if required, will be forwarded at a later date. The validation decals are distinctively colored to indicate the year the number expires (see 33 CFR Part 173). Once approved, a state numbering system is in full effect and exemptions granted by the state are recognized by the Coast Guard. For example, North Carolina's approved system exempts boats powered by electric motors. Although an electrically propelled boat is required by Federal regulations to be numbered, the North Carolina law is controlling, and the Coast Guard will not act against the operator of such a boat in that state.

**NOTE:** 46 U.S.C. 12302(f) states that the SEC DOT may withdraw approval if the state system is not consistent with the Federal system.

---

**4. Offenses Related to Numbering of Undocumented Vessels**

In states that have an approved numbering system, enforcement of the numbering regulations will be deferred to the state authority. Enforcement of numbering regulations is done in the course of enforcement of all federal boating laws and regulations. A Boarding Report (CG-4100) must be forwarded to the district commander for appropriate civil penalty action.

---

**5. Numbering of Certificated but Undocumented Vessels**

- a. Certificated, undocumented vessels. Classes of vessels are required to have a COI, but, due to the nature of their employment, the route upon which they operate, their size, or interagency understandings, are not required to be state or Federally numbered. These include, but are not limited to the following:
  - (1) Public vessels, public school ships, and civilian manned vessels of the Military Sealift Command (MSC), U.S. Navy, or the U.S. Army Corps of Engineers (USACE).

- (2) Barges, sailing vessels, and inland motor vessels carrying flammable or combustible cargo in bulk, or dangerous cargo.
  - (3) Vessels not normally inspected as a consequence of location of operation, which must obtain COIs for changes in location of operation or a change of service (e.g., a barge or dredge which changes location of employment via a route which would subject it to the requirements for seagoing barges).
- b. Procedures. The Coast Guard has established an internal numbering system as a standard for record maintenance and tracking of tank and dangerous cargo barge. This system is used to track vessels through changes of ownership, operators, and names for maintenance of MISLE. Upon receipt of a COI Amendment or Report of Marine Accident, Injury or Death (CG-2692) on a certificated but undocumented vessels, the Marine Safety Information System Branch, Commandant (CG-5PC), will assign to that vessel a number consisting of the letters "CG" followed by six numerals. Cognizant field units will be notified of the number assigned to each vessel; all COIs and reports should list that number in the "Official Number/Award Number" block of the form.

**NOTE:** Owners are encouraged, though not required, to mark their vessels with the Coast Guard number in a manner similar to marking of Official Numbers.

---

---

## CC. INSPECTION AND CERTIFICATION OF MOORED PASSENGER/ATTRACTION VESSELS

---

### 1. Purpose

The purpose of this policy is to set forth procedures for the inspection and certification of temporarily moored attraction vessels as passenger vessels.

---

### 2. Discussion

- a. Attraction vessels are vessels that are put on public display or used as a platform for a public exhibit and carry passengers only while temporarily moored to dock.
  - (1) By charging visitors some form of admission to board, or accepting donations or some other valuable consideration, attraction vessels are subject to U.S. inspection laws as passenger vessels or small passenger vessels.
  - (2) These vessels may operate on an established itinerary, calling on several ports for brief periods of time.

**SECTION B: DOMESTIC INSPECTION PROGRAMS****CHAPTER 4: INSPECTION PROCEDURES APPLICABLE TO VESSEL TYPES, CLASSES, AND CATEGORIES**

- (3) Attraction vessels may be of unique or unusual design, have some historical significance, be restored or constructed as replicas of former vessels, or provide some related maritime interest to the public.
  - (4) Generally, the design or construction of an attraction vessel precludes conformance with or retrofitting to meet U.S. passenger vessel requirements without damaging the originality of the vessel.
- b. The term passenger as used here is the same as defined in 46 U.S.C. 2101(21)(A).

---

**3. General Policy**

- a. In recognition of the reduced safety risks associated with a vessel that is moored to a fixed structure, an attraction vessel may be issued a COI to permit operation as a passenger vessel if the OCMI is satisfied that the vessel can operate safely while moored. For further information, see NVIC 2-00, Section 6.
  - (1) A COI may be issued under this policy with a period of validity up to 1 year and will contain specific operating restrictions, including those addressing local conditions.
  - (2) An attraction vessel with a valid COI that relocates in another OCMI zone will undergo subsequent reinspection by the cognizant OCMI to determine the need to specify operating restrictions based upon local port conditions.
- b. Regardless of the period of validity of the COI, an attraction vessel will be considered to be operating under the terms of its COI only while it is moored at the location(s) and during the period authorized, as specifically endorsed on the COI by the OCMI.

---

**4. Applicability**

These guidelines apply to a vessel which meets the following criteria:

- a. The vessel is a U.S.-flag vessel that is either uninspected or, if inspected, lacks authorization on its COI for the carriage of passengers.
- b. The vessel is a foreign-flag vessel that does not possess a valid SOLAS Passenger Ship Safety Certificate.
- c. The vessel is visiting a port or place for a limited period of time.



- d. The vessel is not permanently moored.
  - e. A charge for admission or some form of compensation or consideration from visitors is required, expected, or accepted in conjunction with boarding the vessel.
  - f. The vessel does not carry passengers while the vessel is underway or at anchor.
- 

## **5. Duration of Operation in a Zone**

This policy is not intended to permit a vessel to circumvent vessel inspection laws by operating as a passenger vessel while moored for an indefinite period of time in the same general area. A period of approximately 1 month at the same location or port area is considered reasonable, however, OCMI's may permit a brief extension of the initial period in unusual circumstances. An OCMI must, when issuing or amending a COI issued pursuant to this policy, specify the dates when and place(s) in the OCMI's zone where the vessel is permitted to operate in the operating details of the COI.

- a. Jones Act status. U.S. Customs, in practice, has not considered a foreign-built vessel moving along the coast and charging a fee for exhibition as coastwise trade, provided promotional literature or articles for sale or exhibit are not loaded and unloaded between coastwise points. If there is doubt as to the applicability of the Jones Act to a particular attraction vessel, an OCMI may require, prior to issuing a COI, the vessel operator to obtain a ruling from the U.S. Customs Service, Office of Regs and Rulings, Entry Procedures and Carrier Branch, 1300 Pennsylvania Avenue, Washington, D.C. 20229, Tel (202) 325-0215.
- b. Application for inspection. To apply for inspection as an attraction vessel, the owner or operator of an uninspected or foreign vessel will submit an application for inspection to the cognizant OCMI. Accompanying the application for inspection, the owner or operator must submit additional vessel information per paragraph 7.a. and a port operating plan containing port-specific information per paragraph 7.b.
  - (1) If the vessel will be operating on an itinerary and calling in other OCMI zones, the owner or operator should arrange for reinspection in subsequent ports, but need only submit a port operating plan in advance.
  - (2) A U.S.-inspected vessel not in passenger service will be required to submit an application for inspection and information to the OCMI.
- c. Additional vessel information and plans required. Accompanying the application for inspection, the owner or operator must provide the following information to the OCMI:

**SECTION B: DOMESTIC INSPECTION PROGRAMS****CHAPTER 4: INSPECTION PROCEDURES APPLICABLE TO VESSEL TYPES, CLASSES, AND CATEGORIES**

- (1) A copy of the vessel's fire control plan or structural fire protection plan, if such plans are available.
  - (2) If a fire control plan in accordance with SOLAS 74 (as amended), Chapter II-2, Reg. 20 is unavailable, a basic plan should be provided, indicating the locations and types of all emergency response or safety-related equipment available on the vessel, including fire fighting, damage control, and lifesaving equipment.
  - (3) The proposed maximum number of passengers to be permitted aboard the vessel, including the calculations used for determining the maximum number of passengers.
  - (4) Results of the most recent hull examination, if any, including an assessment/testament as to the condition of the hull.
  - (5) Copies of any applicable certificates issued by other OCMI's, the vessel's home Administration, or a recognized classification society (e.g., Load Line, SOLAS, etc.).
  - (6) The minimum number of crewmembers to be aboard the vessel during hours of operation and an explanation of their job descriptions and qualifications.
  - (7) Amounts, types and stowage of any flammable or combustible liquids including fuel aboard the vessel.
  - (8) The proposed (general) itinerary of the vessel while in U.S. waters, including ports, dates of arrival and departure.
- d. Submission of Port Operating Plans. A Port Operating Plan must be submitted to the OCMI conducting the inspection for certification and to the OCMI for each subsequent zone where the vessel will be operating. The Port Operating Plan must provide detailed information concerning a vessel's intended operations while in each respective OCMI zone. Each Port Operating Plan should include the following information:
- (1) Approximate dates when the vessel will operate in the OCMI's zone.
  - (2) Location(s) in the OCMI's zone where the vessel will operate.
  - (3) Proposed hours of operation during which passengers would be permitted on board.

- (4) Proposed method for mooring the vessel.
  - (5) Means of access/egress for passengers.
- 

## **6. Inspection for Certification**

The inspection for certification of an attraction vessel should be oriented towards identifying potential hazards to passengers on board that vessel while moored to a pier. In this respect, the requirements and scope of the inspection are significantly less than that for inspection of a vessel carrying passengers underway. The following provides general and specific requirements, particular areas of concern, and suggested equivalent standards of safety for moored attraction vessels.

- a. Pollution regulations. Attraction vessels must comply with the requirements for pollution prevention and marine sanitation devices as found in 33 CFR Parts 151, 155, 156, and 159.
- b. Decks, rails, and stairs. Deck areas, stairs and ladders must be free from tripping, slipping, and falling hazards to passengers. The OCMI may apply the standards for heights of deck rails from the regulations for small passenger vessels in 46 CFR Subchapter T.
- c. Gangways (or brows). Gangways should be suitably sized and located so as to accommodate passenger/crew escape in the event of an emergency.
  - (1) Depending upon vessel arrangement and size and width of the gangway, the OCMI may require the installation of two or more gangways.
  - (2) Inspectors should closely scrutinize any gangway that is attached to the side of a vessel rather than supported by a gunwale or other deck support. Unless properly designed to accommodate the service load and the dynamic forces resulting from tidal changes and vessel surge, the mounting brackets used to attach the gangway to the side of the vessel are subject to potential failure, presenting a serious safety risk to persons using the brow. When side-mounting brackets are used, a redundant means for securing the gangway must be provided. This may be accomplished by use of ropes, chains or cables attached to a secure structure or fitting on deck, which could support the brow in the event of failure of the side brackets.
  - (3) Regardless of design and securing arrangements, OCMI should consider requiring the installation of safety nets below all gangways, where practicable.
- d. Lighting. Interior lighting in areas accessible to passengers should be adequate to the extent that portable lighting equipment should not be necessary. If emergency lights are not installed, the inspector may require guides or crewmembers on watch during hours of operation to carry suitable portable lighting. If the vessel operates at night,

## SECTION B: DOMESTIC INSPECTION PROGRAMS

**CHAPTER 4: INSPECTION PROCEDURES APPLICABLE TO VESSEL TYPES,  
CLASSES, AND CATEGORIES**

- there must be exterior lighting of sufficient intensity for illuminating the weather decks and gangway(s).
- e. Electrical fixtures and wiring. Electrical installations and equipment must be reasonably safe from fire or electrical shock.
- (1) For U.S.-flag vessels, inspectors should refer to the electrical standards in 46 CFR Subchapter J, K, or T (as appropriate) as a general guide.
  - (2) For foreign-flag vessels, the standards found in SOLAS 74/78 (as amended), Chapter II-1, Regulation 45 should be used.
- f. Means of escape from below-deck spaces. If below deck areas will be accessible to passengers, at least two means of escape should be available or, as an equivalent, the number of passengers permitted below decks or in a space below decks at any given time should be restricted.
- (1) The OCMI may also require that passengers be escorted by a crewmember in areas below deck.
  - (2) If below-deck areas have no emergency back-up lighting system, crewmembers assigned to escorting passengers must carry flashlights.
- g. Engine room and bilges. Machinery spaces must be examined for potential fire hazards. If passengers will be permitted in machinery spaces, the vessel operator must identify to the inspector any equipment that may be in operation with passengers on board.
- (1) An examination must be made to detect slipping and overhead hazards, adequacy of guards for rotating machinery, appropriate insulation of hot pipes or equipment, protection of open switchboards, etc.
  - (2) All pressure vessels must be identified to the inspector. If, as a result of the examination, areas are considered dangerous to passengers, they must be declared off limits and required secured during hours of passenger operation.
  - (3) Spaces should also be inspected for evidence of excessive water or oil in the bilges. If such condition exists, it must be corrected to the satisfaction of the OCMI prior to allowing passengers aboard the vessel.

- h. Fire fighting equipment. The OCMI must be satisfied with the amount and type of fire fighting equipment aboard the vessel. The following fire equipment requirements are applicable:
- (1) Fixed fire fighting equipment, if any, and portable extinguishers must be tested or serviced annually to the satisfaction of the OCMI. OCMI may accept certificates issued by a professional service provider as evidence of proper servicing.
  - (2) In determining the number of portable extinguishers required, the OCMI may apply the standards of 46 CFR Subchapter T, K, or H, as appropriate.
    - (a) Portable extinguishers need not be Coast Guard-approved but must be of a marine type.
    - (b) The use of water fire bottles is prohibited.
    - (c) Only carbon dioxide, foam or chemical extinguishers suitable for marine application are permitted.
  - (3) Fire detection and alarm systems, if installed, must be tested to the satisfaction of the OCMI. Passengers must not have access to any space protected by fixed gas (CO<sup>2</sup> or Halon) fire extinguishing system unless the space has a time delay and audible warning device that activates prior to releasing the extinguishing agent. Further, the OCMI must be satisfied that the space has adequate means of escape for the maximum number of passengers permitted in that space at any given time.

**NOTE:** The OCMI may require that fire drill be conducted as part of the inspection for certification.

- i. Lifesaving equipment. A minimum of two ring buoys with lines must be provided on board the vessel. Additional ring buoys with lines as specified by the OCMI may be required. If the vessel operates at night, ring buoys must be outfitted with lights.
- j. Means for retrieval of persons from the water. The vessel must have suitable means or a procedure acceptable to the OCMI for the retrieval of persons from the water. The OCMI may require that a man-overboard drill be conducted as part of the inspection for certification.
- k. Hull condition. The OCMI must be satisfied with the condition of the vessel's hull. When evidence of a satisfactory hull examination or internal structural examination within the past 5 years is unavailable, the vessel may be required to undergo an appropriate hull examination. In such case, the OCMI may require a drydock examination, underwater survey or internal structural examination, as necessary to gain an adequate condition assessment of the vessel hull.

## SECTION B: DOMESTIC INSPECTION PROGRAMS

**CHAPTER 4: INSPECTION PROCEDURES APPLICABLE TO VESSEL TYPES, CLASSES, AND CATEGORIES**

- l. Mooring facilities. The vessel's mooring location, equipment and arrangements must be acceptable to the OCMI.
  - (1) An OCMI should consider the location of the vessel in terms of vessel traffic, nearby waterfront facility operations, and accessibility by emergency responders.
  - (2) The general condition of the pier or other structure that the vessel is moored to should be evaluated for the safe transit of passengers and access by emergency vehicles.
  - (3) OCMI's may use the risk matrix for permanently moored vessels, as found in I.1 of this chapter, as a guide when evaluating mooring arrangements.
- m. Public address system. Vessels that permit passengers below decks must have a public address system or equivalent means, acceptable to the OCMI, to alert the crew and passengers to emergencies and possible evacuation.

---

**7. Operating Conditions and Restrictions**

The OCMI may impose the following operating restrictions, based on the design and construction of the vessel as well as local conditions. In preparing or amending a COI, the OCMI must use the Vessel File Operating Details (VFOD) in MISLE to specify restrictions.

- a. Fires and smoking. Generally, smoking or cooking using an open flame should not be permitted during hours of passenger operation on vessels that do not meet structural fire protection standards for passenger vessels. This restriction may be relaxed for vessels with Coast Guard COIs for service other than a passenger vessel or for foreign vessels with valid SOLAS Cargo Ship Safety Certificates or a Special Purpose Ship Safety Certificates issued in accordance with IMO Resolution A.534(13).
- b. Means of access to the vessel. The vessel must maintain a clear area around the gangway(s) to facilitate evacuation of passengers and access for emergency personnel and equipment.
- c. Passengers permitted. The number of passengers on board must be limited as determined by the OCMI. The OCMI may apply standards from 46 CFR Subchapter T regarding deck area, rail space, or fixed seating, or use stability information on the vessel, if available. The number of passengers permitted may be restricted based upon the number of crewmembers aboard the vessel available to respond to an emergency,

adequacy of escape route(s) or width/number of gangway(s). Passengers must not be permitted to remain overnight or go aloft in rigging.

- d. Emergency plans. OCMI must require the vessel owner or operator to develop emergency action plans to address evacuation of passengers in the event of an emergency on board and procedures for responding to passenger injury. This may include a requirement to submit a copy of a general arrangement plan of the vessel to assist the local fire department or other emergency responders. The OCMI should, as a matter of routine, notify the local fire department regarding an attraction vessel operation and encourage a familiarization visit to the vessel.
  - e. Communications. As a minimum, the vessel should have some form of radio or telephone communications available for emergencies, either on board or reasonably available on the pier. Public pay phones are not an acceptable alternative. Also, a listing of local phone numbers for Coast Guard, fire department, police and other emergency services should be readily available.
- 

## **8. Crew Assignments**

- a. Evaluation of manning adequacy. As part of an inspection for certification, the OCMI must evaluate the crew assignments submitted by the vessel operator to determine if the number of personnel on duty is adequate for crowd control, emergency response and, if required, escorting passengers. The number of crewmembers required on board and on duty while conducting passenger operations should be based on the following minimums:
    - (1) A person in charge, having authority over the vessel operation and crew, must be assigned.
    - (2) A person must be stationed in the immediate proximity of each gangway to monitor the arrival and departure of passengers.
    - (3) Additional personnel must be assigned as necessary for escorting passengers below decks or maintaining a roving safety/fire watch.
  - b. Reduced manning. The OCMI may authorize a reduced number of crewmembers on duty depending upon the number of passengers on board and the configuration of the vessel. This reduction may be contingent upon the vessel operator demonstrating that there are means to adequately monitor the number of passengers on board at any given time.
- 

## **9. U.S. Inspected Vessels Operating as Attraction Vessels**

## SECTION B: DOMESTIC INSPECTION PROGRAMS

**CHAPTER 4: INSPECTION PROCEDURES APPLICABLE TO VESSEL TYPES, CLASSES, AND CATEGORIES**

A U.S. vessel that possesses a valid COI as other than a passenger vessel or small passenger vessel and desires to operate as an attraction vessel must be inspected to the extent necessary to determine that the vessel can safely accommodate the number of passengers requested. Upon requesting inspection, the vessel operator must indicate the number of passengers requested, number and job description of crewmembers aboard, and provide a Port Operating Plan. The vessel's existing COI must be amended to address special operating conditions that may be imposed while the vessel is operating as an attraction vessel.

**10. Operation in Other OCMI Zones**

Vessels that will operate in more than one OCMI zone are subject to a reinspection prior to commencing operation in a new zone to satisfy the OCMI that the vessel is safe for the intended operation. In general, OCMI's should employ the conditions of a previous OCMI, but may impose additional operating restrictions more suitable to local conditions. Insofar as possible, OCMI's should be consistent in their application of conditions and restrictions. The first OCMI who has contact with a vessel that will operate in other zones should obtain the vessel's itinerary and notify the other OCMI's of the vessel's intentions.

- a. MISLE. OCMI's must employ MISLE to enter vessel particulars, record inspection activities and deficiencies, and issue COI's. Detail products in the vessel file (e.g., portable fire fighting and lifesaving equipment) must be entered to the extent necessary to reflect equipment requirements on the COI. Also, an inspection note should be entered in MISLE indicating the vessel's last hull examination date, regardless of whether the examination was attended by Coast Guard inspectors.
- b. Vessel inspection user fees. Because moored attraction vessels are issued Certificates of Inspection, they are subject to paying vessel inspection user fees, unless otherwise exempted. The qualifications for exemption are in 46 CFR 2.10-5.

**NOTE:** These regulations were amended 21 April 1997 and are reflected in the 1998 version of the CFR.

- c. Attraction vessels measuring less than 100 GT will be assessed fees as small passenger vessels; attraction vessels of 100 GT or more will be assessed fees as other vessels. See 46 CFR Table 2.10-101 for a list of fees regarding attraction vessels.



**SECTION B: DOMESTIC INSPECTION PROGRAMS****CHAPTER 5: INSPECTION OF PUBLIC VESSELS****A. INTRODUCTION**

---

Public vessels of the United States, other than those owned or operated by the U.S. Maritime Administration (MARAD), are not generally required by law to be inspected and certificated. However, several government agencies have requested the Coast Guard to assist them by conducting safety inspections on their vessels. In some cases, an agency will request a full inspection resulting in issuance of a Certificate of Inspection (COI). In other cases, the request is for an inspection of limited scope or of specific items. The Commandant intends to cooperate with these agencies by carrying out requested inspections in accordance with inspection agreements, as resources permit. Public vessels subject to inspection under Federal statutes and regulations must be inspected under the appropriate regulations in Title 46 of the Code of Federal Regulations (CFR).

---

---

**B. REFERENCES**

---

**1. Statutes**

The statutes relating to inspection of public vessels are primarily contained in 46 U.S.C. 2101(24) and 2109.

- a. 46 U.S.C. 2101(24) defines a public vessel as one that "is owned, or demise chartered, and operated by the United States Government or a government of a foreign country; and...is not engaged in commercial service."
- b. 46 U.S.C. 2109 states that Subtitle II of Title 46 U.S.C does not apply to a "public vessel of the United States". However, it does apply to vessels (except for St. Lawrence Seaway Development Corporation vessels) owned or operated by the Department of Transportation (DOT) or by any corporation organized or controlled by DOT.

**2. Regulations**

The regulations explaining the application of inspection requirements to public vessels include the following:

**SECTION B: DOMESTIC INSPECTION PROGRAMS****CHAPTER 5: INSPECTION OF PUBLIC VESSELS**

<b>TYPE</b>	<b>CFR CITATION</b>
Tank Vessels	46 CFR 30.01-5(d)(3)
Passenger Vessels	46 CFR 70.05-1(a)(3);
Cargo and Miscellaneous Vessels	46 CFR 90.05-1(a)(4);
Public Nautical School Ships	46 CFR Part 167
Oceanographic Research Vessels	46 CFR 188.05-1(a)(4)

**C. GENERAL INSPECTION PROCEDURES****1. Administrative Procedures**

An Application for Inspection of U.S. Vessel, Form CG-3752, must be addressed to the Officer in Charge, Marine Inspection (OCMI) in whose zone the vessel is located. Upon satisfactory completion of the inspection, the OCMI must issue the vessel a COI. The government agency involved may, upon request, obtain a copy of the certificate. Unless a public vessel is able to comply with all applicable requirements (except as modified by agreements or additional instructions), no COI will be issued. Instead, a letter will be addressed to the agency operating the vessel indicating the extent of the inspection and all deficiencies noted.

**2. Acceptance of Alternate Equipment or Arrangement**

For certain vessels, agreements have been made to accept certain equipment or other standard specifications as equivalent to those specified in the regulations. These equivalents are described below. Inspectors must exercise the same degree of care and diligence in inspecting government vessels as they would for commercial vessels.

**3. Reporting Procedures**

Inspection reports for public vessels must be made in the same manner as for commercial vessels insofar as practicable, in the appropriate Inspection Booklet, CG-840. Specialized local report forms may be used to cover limited inspections. The OCMI must file reports of all inspections. See MSM Volume II, Material Inspection, COMDTINST M16000.7A (Series), Chapter A3.

**SECTION B: DOMESTIC INSPECTION PROGRAMS****CHAPTER 5: INSPECTION OF PUBLIC VESSELS****D. MISCELLANEOUS DECISIONS AND INTERPRETATIONS**

---

**1. Public Vessels**

The term "public vessel," as defined in 46 U.S.C. 2101(24) to obtain exemption from inspection requirements, refers to vessels that are--

- a. Not engaged in commercial service; and
- b. Owned or demise chartered and operated by the United States Government or the government of a foreign country.

**NOTE:** The definition of "public vessel" generally excludes use in trade or commerce. Military vessels which engage in a commercial activity lose their public vessel exemption status for the duration of the commercial operation. They must apply to the OCMI for inspection and certification for the route and service in which they wish to engage.

---

**2. State-Owned Vessels as Passenger Vessels**

The Passenger Vessel Safety Act (PVSA) of 1993 established clear definitions of the terms "passenger," "passenger for hire," "passenger vessel," "small passenger vessel," and "uninspected passenger vessel." These definitions should alleviate the former difficulties in determining whether or not state owned vessels are subject to inspection.

---

**3. Carriage of Vehicles Containing Hazardous Materials**

There is no regulatory basis for the inspection of vessels based solely on their carriage of transport vehicles containing hazardous materials.

- a. With regard to the transportation of hazardous materials in the transport vehicles carried on vessels, the Coast Guard may still enforce the provisions of 49 CFR Part 176, specifically 49 CFR 176.11(d). Additionally, free ferries (state-owned and operated vessels which do not charge) meet the definition of uninspected vessels in 46 U.S.C. 2101(43) and are therefore subject to the provisions of 46 U.S.C Chapter 41 as well as 46 CFR Subchapter C.

**SECTION B: DOMESTIC INSPECTION PROGRAMS****CHAPTER 5: INSPECTION OF PUBLIC VESSELS**

**NOTE:** Free ferries are uninspected vessels but they do not meet the definition of “uninspected passenger vessels” because they do not carry passengers for hire.

- b. In addition to the safety oversight, there is also authority under the Ports and Waterways Safety Act, 33 U.S.C. 1223, to impose conditions of operation on free ferries if there is a determination that such action is justified in the interest of safety.
  - (1) This means that that, should the Captain of the Port (COTP) determine that the carriage of hazardous materials aboard these vessels is unsafe for passengers; the COTP can impose specific conditions of operation on these vessels.
  - (2) Before doing so, the COTP is required to take into account the considerations established in 33 U.S.C. 1224. Issues which may be considered as conditions of operation are not limited to the vessel’s structural condition, equipment, or route, but, if deemed appropriate, could include items such as restricting passenger carriage and/or imposing crew qualifications while the vessel is carrying hazardous materials.

---

**E. VESSELS OF THE MILITARY SEALIFT COMMAND (MSC)**

---

**1. Inspection Agreement**

The Commander, Military Sealift Command (MSC) (an arm of the U.S. Navy (USN)) has requested that the Coast Guard inspect and certificate MSC vessels, which are operated by civilian merchant mariners. Such a vessel is normally designated "MSC, in service, civilian-manned" on the COI. The term "in service" contrasts with "commissioned" naval ships, which are manned by military personnel. MSC intends that no civilian-manned vessel will be operated without a COI, unless military requirements make it necessary.

The Coast Guard will not normally be asked to inspect and certificate the following vessels:

- a. Those vessels controlled by the Commander, MSC Far East Area.
- b. Landing craft-type vessels, such as Landing Ships, Tank (LSTs) and Landing Crafts, Medium (LCMs).
- c. Vessels that are essentially military in character, by virtue of assignment or construction standards.

**SECTION B: DOMESTIC INSPECTION PROGRAMS****CHAPTER 5: INSPECTION OF PUBLIC VESSELS**

The Coast Guard will inspect MSC vessels for which inspection requests are filed to verify that they comply with the appropriate requirements. OCMI's must certificate MSC vessels that comply with the regulations (as modified by further agreements or instructions). COI's must not be issued to MSC vessels that do not meet the requirements.

**2. Applicability of SOLAS 74/78**

Vessels certificated as "MSC, in service, civilian-manned" are Department of Defense (DOD) vessels used for public purposes. They are not subject to the requirements of the 1974 SOLAS Convention and its 1978 Protocol, and will not receive SOLAS certificates, even if the vessel meets SOLAS in full and a certificate is requested by MSC. A letter stating the vessel's compliance may be issued.

**NOTE:** This provision does not apply to those commercial vessels on time charter to MSC from MARAD.

**3. COI Modifications**

- a. Route permitted and conditions of operation. An asterisk must be inserted at the word "thereunder" in the eighth line of an MSC vessel's COI Form CG-841. In the space for "Route Permitted and Conditions of Operation" there must be an asterisk and the notation "In accordance with the standards applicable to MSC vessels."
- b. Class. In the space provided for the vessel's class, insert the designations "Naval transport/cargo vessel/tankship (as appropriate), in service, civilian-manned."
- c. Manning. In the case of P2, C3, and C4-type vessels, the presence aboard of three additional Able Seamen, not required to stand watches, must be included in persons authorized to be carried in the crew.
- d. Persons in addition to the crew. When deemed necessary for defense purposes by the Commander, MSC, inspected MSC vessels may carry civilian or military personnel in addition to the crew expressly to carry out vessel missions. Such personnel must not be involved in the navigation of the vessel and are not considered members of the crew or passengers. Their presence must be indicated in a separate endorsement of the COI and reflected in the total of persons allowed aboard.

## SECTION B: DOMESTIC INSPECTION PROGRAMS

## CHAPTER 5: INSPECTION OF PUBLIC VESSELS

**4. Regulatory and Equipment Modifications**

- a. In addition to material normally accepted by the Coast Guard, the OCMI may accept materials and equipment on MSC vessels that meet the requirements of any of the following authorities:
    - (1) The technical bureaus of the Department of the Navy.
    - (2) Military specifications (MILSPECs), including Joint Army Navy (JAN) specifications.
    - (3) Federal specifications used for military purchases.
    - (4) National Military Establishment (NME) specifications.
  - b. Vessels of special design. The Commandant may, in cases of specially designed MSC vessels, permit variations from statutory and regulatory requirements if they are necessary for the special purposes for which the vessels are intended. Initial inspection files must include correspondence and other information on the variations allowed; these should be consulted at subsequent inspections for certification.
  - c. Structural steel renewals. These must incorporate at least the minimum requirements of the Coast Guard and the American Bureau of Shipping (ABS).
  - d. Lifesaving equipment. Requirements for lifesaving equipment on inspected vessels are shown in Figure B5-1. Percentage requirements are based on the total number of persons on board.
  - e. Pyrotechnics. USN pyrotechnics may be carried in lieu of Coast Guard approved pyrotechnics.
  - f. Lifefloats. USN lifefloats that are identified by nameplates as complying with the provisions of MILSPEC MIL-F16143 are acceptable, provided they are in good condition.
  - g. Canned drinking water. Emergency drinking water canned under MILSPEC MIL-W-15117 may be accepted in lieu of Coast Guard approved drinking water. Such cans are undated and may remain in service for an indefinite period. Rejection must be based on deterioration of cans or other defects that the inspector judges to make the water unusable. Coast Guard-approved water cans will be rejected after five years.
-

**SECTION B: DOMESTIC INSPECTION PROGRAMS****CHAPTER 5: INSPECTION OF PUBLIC VESSELS****5. Inspection Waivers**

Waivers from inspection requirements must be made in accordance with the provisions of 46 CFR 6.06.

---

**6. Cargo Tank Examinations for Marine Prepositioning Ships (MPS)**

It is understood that Marine Prepositioning Ships (MPS) carry large quantities of bulk liquid cargo. Therefore, it may be impracticable to conduct cargo tank internal inspections except when the vessels are in drydock and the cargo tanks are gas free. Inspections of any tanks which are gas freed, safe for entry, and accessible, together with internal structural examinations, may be conducted to satisfy the requirement for alternate cargo tank internal examinations. These inspections must be conducted to the satisfaction of the OCMI.

---

---

**F. VESSELS OF THE U.S. ARMY CORPS OF ENGINEERS (USACE)**

---

**1. Inspection Agreement**

Upon application for inspection, the Coast Guard will inspect and certificate U.S. Army Corps of Engineers (USACE) vessels that comply with applicable statutory and regulatory requirements. When a USACE vessel does not comply with requirements, a written statement of the conditions found will be forwarded to USACE with the returned application.

---

**2. Regulatory and Equipment Modification**

- a. Lifesaving equipment. At the request of the Chief of Army Engineers, the Commandant has accepted unicellular plastic lifesaving ring buoys, MILSPEC MIL-R-0016847, for use on USACE vessels.
  - (1) The Coast Guard has reached an agreement with USACE on upgrading the safety standards for lifesaving equipment. The USACE has agreed to replace unicellular plastic foam work vests (MIL-L-17653) with Coast Guard-approved Personal Flotation Devices (PFDs).
  - (2) The old work vests will be replaced on all USACE vessels except those engaged on river routes, in quantities specified by Coast Guard regulations. The old work vests may be retained for use by crewmembers working near or over the water, as per the regulations.

**SECTION B: DOMESTIC INSPECTION PROGRAMS****CHAPTER 5: INSPECTION OF PUBLIC VESSELS**

- b. Manning. Vessel manning issues are discussed in the MSM Volume III, Marine Industry Personnel, COMDTINST M16000.8B (Series).
- 

**G. DOD/NATIONAL AERONAUTICS AND SPACE ADMINISTRATION (NASA)  
INSTRUMENTATION SHIPS**

---

**1. Introduction**

Special-purpose ships that are owned by the United States and operated as public vessels to provide instrumentation facilities for DOD and the National Aeronautics and Space Administration (NASA) missile and space programs are classed as "instrumentation ships." These are under the control of the Commander, MSC.

---

**2. Inspection and Certification**

Upon application, these vessels will be inspected and certificated by the Coast Guard. 46 CFR Subchapter I (Cargo and Miscellaneous Vessels) applies to instrumentation ships, insofar as practical. The entry for "Total persons allowed" on the COI must be the maximum number permitted by the Coast Guard (normally, the capacity of the primary lifesaving equipment aboard will be the determining factor). Such vessels manned by military rather than civilian personnel will be awarded Letters of Inspection in lieu of COIs. Civilian crewmembers must be licensed or certificated as a condition of employment on such vessels. When the number of persons aboard exceeds normal manning standards or the vessel varies significantly from the standard "cargo ship" configuration, additional requirements for improved access and fire protection may be imposed.

---

**3. Special Instrumentation Equipment**

In regard to special instrumentation equipment for instrumentation vessels, the Coast Guard exercises plan approval and inspection of electrical distribution systems only to the point of the vessel's electrical power takeoff. The Coast Guard's concerns are fire, personal hazard, and interference to the vessel's service power or main propulsion plant that may be caused by instrumentation systems, not the proper functioning of such systems themselves.

---



**SECTION B: DOMESTIC INSPECTION PROGRAMS****CHAPTER 5: INSPECTION OF PUBLIC VESSELS****4. Manning Standards**

The OCMI specifies the minimum manning requirements for instrumentation ships on the COI. The OCMI does not limit categories of persons on board instrumentation ships. For "normal" operation under the COI, the Commandant requires manning by properly licensed and certificated personnel in the deck, engineering, staff, and steward departments. All persons not employed in those categories are considered "other persons employed or engaged in any capacity on board a vessel on the business of the vessel" (see 46 CFR 90.10-29) and are not required to hold Merchant Mariner's Credentials).

**NOTE:** For more information, see the MSM, Volume III, Marine Industry Personnel, COMDTINST M16000.8B (Series).

---

**5. Accommodations**

The requirements of 46 CFR 92.20 do not apply to "other persons employed or engaged in any capacity on board a vessel on the business of the vessel."

---

**6. Operation under Special Conditions**

Under certain unforeseen conditions and mission requirements, it may be necessary for instrumentation ships to sail under conditions not permitted by the COI. When such conditions prevail, the Commander, MSC will authorize the vessel to sail without compliance and notify Commandant (G-MOC) of such authorization.

---

**7. Casualty Review**

The Masters/Commanding Officers (COs) of civilian or military manned instrumentation ships are not required to report marine casualties to the Coast Guard, and the Coast Guard will not investigate such casualties unless specifically requested to by DOD. However, contract-operated instrumentation ships and their masters are required to report marine casualties to the Coast Guard, which will investigate them unless specifically requested not to by DOD.

**NOTE:** For more information, see the MSM Volume V, Investigations and Enforcement, COMDTINST M16000.10A (Series).

## SECTION B: DOMESTIC INSPECTION PROGRAMS

## CHAPTER 5: INSPECTION OF PUBLIC VESSELS

**8. Disciplinary Actions Against Crewmembers**

Necessary disciplinary actions must be taken in accordance with existing agreements, modified as necessary, between the Coast Guard and MSC. See MSM V for more information on this subject.

---

**9. Lifesaving Equipment**

- a. Lifeboats. Generally, these must be approved under 46 CFR 160.035 for a 200-percent requirement. If the vessel meets requirements for one-compartment subdivision and stability in accordance with 46 CFR Parts 73-74, only 100-percent lifeboatage is required.
  - b. PFDs. These must be approved under 46 CFR 160.002, 160.005, or 160.055, or USN MIL-L-10845, for a 100-percent requirement.
  - c. Inflatable life rafts. These must be approved under 46 CFR 160.051. 46 CFR 94.10-55 provides for certain substitutions of inflatable life rafts for lifeboats.
- 

**10. Pyrotechnics**

USN pyrotechnics are acceptable.

---

**11. Repairs and Alterations**

Plan approval for new construction, conversion, and alterations must be carried out in accordance with applicable Coast Guard regulations. Notice of repairs or alterations must be submitted to the Coast Guard in accordance with 46 CFR 91.45-1. Inspections of such alterations or repairs must be accomplished in accordance with 46 CFR 91.45-5.

---

---

**H. NATIONAL OCEANOGRAPHIC AND ATMOSPHERIC ADMINISTRATION (NOAA) VESSELS**

---

Only 100-percent lifeboatage is required for NOAA vessels that meet one-compartment subdivision and stability requirements.

---

---

**I. VESSELS CHARTERED BY THE NATIONAL MARINE FISHERIES SERVICE (NMFS)**

**SECTION B: DOMESTIC INSPECTION PROGRAMS****CHAPTER 5: INSPECTION OF PUBLIC VESSELS**

---

**1. Introduction**

An inspection agreement between the Coast Guard and the National Marine Fisheries Service (NMFS) concerns commercial fishing vessels chartered to the agency for regulatory or research purposes. When a commercial fishing vessel is selected by NMFS for a charter, the Coast Guard District Fishing Vessel Safety Coordinator or local MSO examiner will be informed of the vessel's name, official number and location in order to schedule an agreeable time to conduct a dockside examination.

---

**2. Inspection Standards**

NMFS chartered vessels must comply with all applicable laws and regulations for fishing vessels. The Fishing Vessel Examiner will conduct a dockside examination of the vessel. The examination record must indicate whether or not the vessel is in compliance with applicable regulations. The Examiner must leave the original inspection booklet aboard the vessel, retain a copy locally, and forward copies to the NMFS and the District Fishing Vessel Safety Coordinator.

---

**3. Standards of Seaworthiness**

NMFS will make a careful selection of the vessels it desires to charter to ensure that they are basically seaworthy. The Coast Guard examination is not primarily an inspection for seaworthiness. However, unsafe structural conditions that are observed must be reported to Commandant (CG-CVC), and a Letter of Inspection must not be issued. In such a case, NMFS generally will cancel the charter and hire another vessel.

---

**4. Letters of Inspection**

Vessels that comply with the applicable requirements must be issued Letters of Inspection by the OCMI. A sample letter is located in Figure 12-2. The original Letter of Inspection must be posted aboard the vessel, with a copy retained by the OCMI and two copies forwarded to Commandant (CG-CVC).

---

**SECTION B: DOMESTIC INSPECTION PROGRAMS**

**CHAPTER 5: INSPECTION OF PUBLIC VESSELS**

**FIGURE B5-2: SAMPLE LETTER OF INSPECTION FOR  
CHARTERED COMMERCIAL FISHING VESSELS**

This letter expires on (expiration date of charter).

The (VESSEL NAME), (O.N.), was inspected by the Coast Guard on (DATE), at (PLACE) and was found to be in compliance with the applicable inspection criteria approved jointly by the National Marine Fisheries Service and the U.S. Coast Guard.

This vessel is considered satisfactory for operation during the period of charter on (ROUTE).

It is understood that a maximum of crew and persons in addition to the crew will be carried. Total persons allowed is (#).

Primary Lifesaving

Portable

Fixed

Equipment Data

Fire Extinguisher Data

Officer in Charge, Marine Inspection  
Inspection Zone

**SECTION B: DOMESTIC INSPECTION PROGRAMS****CHAPTER 5: INSPECTION OF PUBLIC VESSELS**

---

---

**J. VESSELS CHARTERED BY THE INTERNATIONAL HALIBUT COMMISSION**

---

Vessels chartered by the International Halibut Commission must be inspected and certificated in the same manner as NMFS chartered vessels.

---

---

**K. INSPECTION OF BOILERS OR PRESSURE VESSELS ON FLOATING EQUIPMENT**

---

**1. Application for Inspection**

Application for inspection of boilers or pressure vessels only, on Federally-owned floating equipment, must be made to the OCMI in whose zone the equipment is located.

---

**2. Inspection Reports**

All reports concerning such inspections must normally be made on the form(s) supplied by the agency with custody of the equipment being inspected. Such forms must normally be filed by the OCMI.

Copies of the report must be forwarded to the representative of the agency involved.

---

---

**L. MARITIME ADMINISTRATION READY RESERVE FORCE (RRF) VESSELS**

---

**1. Introduction**

As noted in the introduction to this chapter, public vessels are not generally subject to inspection, except for those owned or operated by the MARAD. Coast Guard policy concerning inspection of MARAD Ready Reserve Force (RRF) vessels is outlined in a Memorandum of Understanding (MOU) between the Coast Guard and MARAD and is contained in the MSM Volume X, Interagency Agreements and Acronyms, COMDTINST M16000.15A (Series). This MOU recognizes the special nature of these vessels and the need for a special inspection policy.

---

## SECTION B: DOMESTIC INSPECTION PROGRAMS

## CHAPTER 5: INSPECTION OF PUBLIC VESSELS

**2. Background**

MARAD vessels which are being maintained in continuous operation generally conform to the same regulations and inspection intervals applicable to their commercial counterparts. However, most RRF vessels spend the majority of their life in a deactivated, non-operational status. Because of this unique set of circumstances, the USCG/MARAD MOU allows inspection intervals to be modified and the correction of outstanding deficiencies delayed when RRF vessels are in a deactivated status. The current MOU was a direct outgrowth of lessons learned by both OCMI's and MARAD personnel during RRF vessel inspections conducted for activation in support of operation DESERT SHIELD/DESERT STORM (August 1990 to July 1991). The MOU is intended to permanently capture the knowledge and experience gained during this first large scale activation of the RRF since its creation in 1976.

---

**3. Summary of Significant Additions to the USCG / MARAD MOU**

- a. Annex III, command, control and communication. A third annex was added to the MOU which outlines procedures for coordination and communication between USCG/MARAD and contract vessel operators at various levels within each organization. This third annex emphasizes early and frequent communication for resolution of inspection issues.
- b. Time limit for completion of deficiencies. A limit of one year after completion of the inspection for certification was placed on correction of material deficiencies for RRF vessels in phase IV, maintenance.
  - (1) Under the previous MOUs, material deficiencies could be deferred indefinitely during phase IV until the vessel was activated for operations. Attempting to correct all these deficiencies upon activation resulted in substantial delays to commencement of operations.
  - (2) This time limit is intended to minimize the number of deficiencies which will require correction should an RRF vessel be required to activate on short notice. By allowing a year from the date the COI inspection is completed to correct deficiencies, MARAD has retained the flexibility to schedule necessary shipyard periods and operational tests of the vessels' systems during phase IV.
- c. RRF vessels in phase IV that exceed the time limit for correction of deficiencies. The MOU allows OCMI's to remove RRF vessels from certificated status if deficiencies remain uncompleted beyond the allowable time limit established in the MOU.

**SECTION B: DOMESTIC INSPECTION PROGRAMS****CHAPTER 5: INSPECTION OF PUBLIC VESSELS**

- (1) This is not intended to be a punitive measure. The intention of this provision is to match inspections to those periods when actual repairs or operations are being conducted. OCMI's should focus inspections on those periods when the vessel is ready to make repairs, conduct tests, or demonstrate the proper operation of equipment or systems.
- (2) If an RRF vessel cannot conduct required repairs, tests, or inspections before the time limit, it lapses into a period during which its COI is no longer valid. However, because MARAD may seek to recertificate the vessel at a future date, OCMI's should retain vessel files, update records of the vessel, and witness equipment tests and repairs when requested to do so by MARAD or their authorized representative.
- (3) The goal of both MARAD and the Coast Guard in the inspection process is to maintain RRF vessels in a certificated status with valid COIs in the possession of the vessels' operator. Ideally, the only outstanding deficiencies on any RRF vessel in phase IV should be to witness reinstallation and testing of equipment which has been intentionally removed to prevent damage during extended periods of deactivation.

---

**4. National Defense Waiver Requests**

When necessary, national defense waiver requests will be coordinated between MARAD and DOD and submitted to the Coast Guard under authorized DOD signature. The previous MOU required the same level of coordination, but directed MARAD to sign and submit the waiver form. 46 CFR Part 6 gives DOD the right to waive inspection requirements for the purpose of national defense for vessels operated or chartered by DOD, in this case, RRF vessels. Other government agencies may request a waiver of inspection requirements from the Coast Guard based on national defense if "the urgency of the situation outweighs the marine hazard involved" (46 CFR 6.01(b)). Because of MARAD's location within the Department of Transportation, vice DOD, the Coast Guard could deny MARAD's requests for national defense waivers if it did not meet regulations. This change to the MOU places the evaluation of the level of hazard to RRF vessels and crew with DOD when the primary consideration is national defense. The Secretary of Defense has delegated signature authority for national defense waivers to the Commander, MSC.

---

**SECTION B: DOMESTIC INSPECTION PROGRAMS****CHAPTER 6: POLLUTION PREVENTION****A. INTRODUCTION**

The oceans and waterways of the world have long been used by the maritime community, shoreside industries, and municipalities as catchalls for domestic and industrial wastes. Pollution results from acts of commission and omission. In either case, the technology to measure and combat the detrimental effects of pollution is available or is being developed.

---

**1. Waterways Pollution**

Our waterways are susceptible to pollution from many sources. Particulates are discharged into the air from industrial, utility, and transportation systems, and eventually enter the water through rainfall runoff or direct discharge. Ground water carries pesticides and other pollutants from rural areas into the waterways. There has been a rapid increase in the bulk transportation of hazardous substances on the nation's waterways. Oil and petroleum based products are highly visible examples, but by no means the only substances of this type (nor the most dangerous) that are moving continually through U.S. waters. The likelihood of catastrophic incidents involving these substances is a matter of constant concern. Less spectacular, everyday incidents such as vessel collisions, groundings, and failures of cargo transfer systems also result in the pollution of the marine environment. Pollution can occur in the ocean transport of oil in bulk quantities due to tank cleaning and ballasting operations, as well as the ballasting of fuel tanks in other types of vessels. Yet another pollutant, sewage finds its way into the water system. While municipal, private, and industrial sewage systems contribute the largest percentage of sewage to the waterways, a significant amount originates from commercial and private vessels.

---

**2. Legislation**

Congress has enacted legislation to restrict the discharge of pollutants into U.S. waters and to punish violators. The following is a list of the more popular congressional enactments:

Among these enactments are--

- a. The Federal Water Pollution Control Act (FWPCA), as amended, 33 U.S.C. 1251 et seq. (also known as the Clean Water Act);
- b. The Ports and Waterways Safety Act (PWSA), as amended, 33 U.S.C. 1221 et seq.;
- c. The Port and Tanker Safety Act (PTSA), 33 U.S.C. 1221 and 46 U.S.C. Chapter 37;
- d. The Marine Protection, Research and Sanctuaries Act (MPRSA), 33 U.S.C. 1401 et seq.;



**SECTION B: DOMESTIC INSPECTION PROGRAMS****CHAPTER 6: POLLUTION PREVENTION**

- e. The Act to Prevent Pollution From Ships (APPS), 33 U.S.C. 1901 et seq., resulting from the International Convention for the Prevention of Pollution from Ships (MARPOL 73/78); and
- f. The National Environmental Policy Act (NEPA), 42 U.S.C. 4321 et seq.).

**NOTE:** See MSM Volume I, Administration and Management, COMDTINT M16000.6 (Series) for a detailed explanation of these acts.

---

**3. FWPCA and MARPOL 73/78**

The principal statutes for controlling marine pollution are the FWPCA and APPS (MARPOL 73/78), which provide for the prevention of marine pollution by oil, hazardous substances, and sewage. The FWPCA further provides for early detection and notification of Federal authorities of discharges, enforcement actions in the event of violations, response and cleanup activities, and the regulation of Marine Sanitation Devices (MSDs) to comply with the standards set by the Environmental Protection Agency (EPA). It is the prevention aspect of the FWPCA, MARPOL 73/78, and supporting regulations, that is addressed in this chapter.

---

**4. Prevention Aspect**

The prevention aspect of the FWPCA and MARPOL 73/78 and their implementing regulations include the control of commodity handling operations, and the design and construction of vessels and facilities (onshore and offshore), to minimize the occurrence of harmful discharges. To this end, the Coast Guard and EPA share Federal responsibility for pollution prevention. The EPA is responsible for all facilities onshore, and up to 200 miles offshore, that are not transportation related. This includes facilities that drill, produce, gather, store, process, refine, transfer, distribute, or consume oil and hazardous substances (see 40 CFR Part 112). The Coast Guard, under the authority of 33 U.S.C. 1321(j)(1), promulgates regulations that provide equipment requirements, operating procedures, and training of personnel from vessels as well as from onshore and offshore facilities.

---

**SECTION B: DOMESTIC INSPECTION PROGRAMS****CHAPTER 6: POLLUTION PREVENTION****B. OIL POLLUTION PREVENTION REQUIREMENTS**

---

**1. Regulations**

The regulations for the prevention of water pollution are authorized by 311(j)(1)(C) and (D) of the FWPCA, as amended (33 U.S.C. 1321 et seq.). Revised regulations, 33 CFR Parts 154-156, became effective on 3 March 1980. The regulations were revised to better address routine operations, such as cargo tank cleaning, bilge pumping, ballasting, equipment failure, and human error, which are the most frequent causes of oil spills. These operational spills can be prevented by maintenance and testing of equipment, personnel awareness, and proper procedural requirements.

---

**2. Intent**

The intent of the pollution prevention regulations is to prevent pollution through good marine practice as well as compliance with the letter of the law. If violations are detected during routine inspections, correction is the initial action to be taken; this must be followed by a Report of Violation and formal penalty action, if appropriate (see MSM Volume I, Administration and Management, COMDTINST M16000.6 (Series) and MSM Volume V, Investigations and Enforcement, COMDTINST M16000.10 (Series) for more information).

---

---

**C. REQUIREMENTS FOR OIL TRANSFER FACILITIES (33CFR PART 154)**

---

**1. Applicability (33 CFR 154.100)**

- a. The regulations are aimed at preventing oil discharges that threaten substantial pollution of U.S. navigable waters.
  - (1) The regulations are not intended only to collect civil penalties.
  - (2) If violations are detected during routine inspections or examinations, correction is the primary objective.
  - (3) Marinas normally do not transfer oil in quantities that justify stringent regulation. Additionally, Coast Guard personnel are not available to monitor all minor oil transfer operations.

**SECTION B: DOMESTIC INSPECTION PROGRAMS****CHAPTER 6: POLLUTION PREVENTION**

- (4) Marinas are subject to 33 CFR Part 154 when transfers involve vessels with a capacity of 250 barrels (10,500 gallons) or more of oil. Such vessels pose a genuine risk of pollution, even when lesser quantities of oil are actually transferred.
  - (5) 33 CFR Part 154 applies to onshore facilities as defined in 33 USC 1321(a)(10) and to offshore facilities within U.S. navigable waters.
- b. Federally owned and operated facilities. Federal facilities, regardless of the character of the vessels they service, come under the purview of 33 CFR Parts 154 and 156 (this includes Department of Defense (DOD) and Coast Guard facilities). Primary responsibility for enforcing the requirements of 33 CFR Parts 154 and 156 at Federally owned and operated facilities resides with the Federal agency that owns and operates the facility, not with the Coast Guard. However, consistent with its general enforcement responsibility and in the public interest, the Coast Guard will do the following:
- (1) Support and assist the efforts of the Federal agency involved to comply with the pollution prevention regulations.
  - (2) Conduct inspections and monitor transfer operations at such facilities, and enter such facilities to gain access to commercial vessels berthed there, when approval is granted by the cognizant Federal agency.
  - (3) Advise other agencies of violations, when observed or reported, and of requirements that must be met to achieve compliance.
- c. When a violation is observed at a Federally owned and operated facility, the Captain of the Port (COTP) must--
- (1) Formally advise the responsible official of the violation(s);
  - (2) Explore all possible means of resolving the matter and achieving compliance; and
  - (3) Submit relevant documentation to the district commander for disposition if compliance is not forthcoming.
- d. Upon receipt of documentation from the COTP indicating violations at such facilities, the district commander must explore all possible means of reaching a mutual agreement for achieving compliance. Such efforts must be undertaken with the district commander's counterpart in the cognizant agency, e.g., the regional administrator, district commandant, or district engineer and be fully documented. If this fails to

**SECTION B: DOMESTIC INSPECTION PROGRAMS****CHAPTER 6: POLLUTION PREVENTION**

achieve a resolution of the situation, provide Commandant (CG-5P) all relevant information for resolution with the parent agency.

- e. Federally owned, privately operated facilities. Routine enforcement policy and procedures apply to violations at such facilities.
- 

**2. Definitions (33 CFR 154.105)**

The definition of "transfer," in clarifies the applicability of the regulations to transfers of oil within vessels. This definition also applies to 33 CFR 155 and 33 CFR 156. The definition of "oil" in 33 USC 1321(a)(1) applies to these regulations. "Oil" does not include liquefied flammable gases, or any substance designated by EPA as a "hazardous substance" in 40 CFR 116. This includes animal and vegetable oils. The regulations apply to bulk transfers of any kind of oil to or from a vessel with a capacity of 250 barrels or more.

---

**3. Alternatives (33 CFR 154.107)**

33 CFR 154.107 is worded so that the COTP may consider both economic and physical conditions when reviewing a proposed alternative to the regulations. However, the intent of the regulations should not be circumvented without good reason, even when alternative protection is afforded. Alternative requests should document the equivalency of protection.

- a. Documentation. Documentation of alternatives to the regulations, including safety and pollution protection measures, is required.
  - (1) The COTP may request additional information from the owner or operator, if necessary, to evaluate the proposed alternative. A request must include an economic and environmental analysis.
  - (2) As an equivalent level of protection is required, no formal environmental impact statement is necessary.
- b. Waivers. Waivers from compliance are granted as alternatives (granted by the COTP) or exemptions (granted only by the Commandant).
  - (1) COTPs must review waivers that were granted under the initial regulations to determine which waivers must be submitted to Commandant (CG-5P) for reapproval as exemptions.
  - (2) Most requests for deviations from the regulations should be processed as alternatives.

**SECTION B: DOMESTIC INSPECTION PROGRAMS****CHAPTER 6: POLLUTION PREVENTION**

- (3) A request that provides an alternative means of compliance that involves numerous facilities scattered throughout several COTP zones should not be treated as an exemption request simply because of the multiple, variously located facilities.
- (4) Alternative procedures approved by the COTP should be described in the facility's the operations manual as well as the COTP's facility file.

---

**4. Exemptions**

Exemption requests must be forwarded to the Commandant only when all means of alternative compliance have been exhausted. For the relevant regulations, see 33 CFR 154.108. When appropriate, exemption requests forwarded to Commandant (CG-5P) must include observations or assessments of the situation from the COTP. These will aid in determining whether or not to grant an exemption.

---

**5. Letter Of Intent**

The operator, for purposes of the letter of intent, is the party responsible for the facility. This may not necessarily be an individual; if a corporation owns and operates a facility, the operator is that corporation and not any operating employee. For the relevant regulations, see 33 CFR 154.110.

---

**6. Facility Examinations**

Normally, examinations for compliance with 33 CFR Parts 154 and 156 are conducted during working hours. However, the COTP must conduct examinations whenever the facility is operational, as deemed necessary. Facility inspections must proceed inshore from the dock area as far as necessary to identify the oil transfer system, including the piping arrangement used to transfer oil to or from the storage or processing operations. For the relevant regulations, see 33 CFR 154.120.

---

**SECTION B: DOMESTIC INSPECTION PROGRAMS****CHAPTER 6: POLLUTION PREVENTION****7. Requirement for Operations**

Each facility must have an operations manual sufficient to guide a person generally qualified in oil transfer operations in performing his or her duties in an environmentally safe manner. These manuals are intended to be working documents for the benefit of personnel involved in oil transfer operations. At a minimum, the operations manual must be understood by all who are designated as a Persons in Charge (PIC). The operations manual should be the single source for learning standard operations as well as emergency procedures at a facility. Small facilities should have simple manuals; larger, multiproduct facilities require more comprehensive manuals. The requirement to send a copy of the operations manual with the letter of intent enables the COTP to verify that the owner/operator has established procedures for the facility to operate in an environmentally sound manner. The contents of certain manuals may be proprietary in nature. Therefore, the contents of operations manuals normally must not be released to others unless authorized in writing by the facility owner/operator. Seek legal advice if requests for information are received. For the relevant regulations, see 33 CFR 154.300.

---

**8. Contents of Operations Manual**

Personnel should know the locations of all required safety equipment. Providing cargo information is the responsibility of the vessel operator. This data must be readily available to facility personnel for safety and environmental reasons. A list of personnel names and telephone numbers may be on a separate sheet for easy amendment the regulations permit the operations manual to be in loose-leaf form for this purpose. For the relevant regulations, see 33 CFR 154.310.

---

**9. Amendments to the Operations Manual**

COTPs review operations manuals for the facilities in their zones. Facilities making substantial changes to their existing manuals must follow the procedure set forth in 33 CFR 154.320(b). A letter of adequacy addresses the scope of the manual's contents and ensures that certain information is covered in the manual, but does not constitute Coast Guard approval or certification of any particular procedure or equipment mentioned. For the relevant regulations, see 33 CFR 154.320.

---

**10. Examination of Operations Manual**

For the relevant regulations, see 33 CFR 154.325.

---

**SECTION B: DOMESTIC INSPECTION PROGRAMS****CHAPTER 6: POLLUTION PREVENTION****11. Hose Assemblies**

- a. Maximum Allowable Working Pressure (MAWP). 33 CFR 154.500(b) requires oil transfer hose assemblies to have a MAWP more than the sum of the relief valve setting (or the maximum pump pressure when no relief valve is installed) plus static head pressure of the transfer system at the point where the hose is installed.
    - (1) For more information on testing pressures, see subparagraph E.8.b below.
    - (2) For the relevant regulations, see 33 CFR 154.500.
  - b. Marking. 33 CFR 154.500(e)(1) requires marking the MAWP on the hose. Do not mark burst pressure or test pressure on the hose. Pressures other than MAWP that are marked on hoses presently in use may be obliterated by any suitable means until replaced by hose with proper markings.
  - c. There is no need to test back pressure nozzles, as they are reliable for the small hoses with which they are used. They are not intended for large hose, which is not used with flush deck fittings.
- 

**12. Loading Arms**

This section provides a uniform and safe standard for loading arms that is not subject to undue modification. An alternative under 33 CFR 154.107 may be requested for locally constructed arms. To avoid expensive retrofitting, only loading arms installed after 30 June 1973 are regulated. Manufacturers should be consulted in questionable cases. For the relevant regulations, see 33 CFR 154.510.

---

**13. Monitoring Devices**

The primary purpose of these regulations is to provide monitoring systems for the detection of spilled oil to ensure adequate and rapid clean-up efforts. This requirement is intended only for those cases in which visual surveillance is insufficient to detect oil spills in very sensitive areas, or in which a complex operation would likely result in a large spill without the presence of a monitoring device. In such cases, use of the oil monitor should significantly increase the probability of detection or limit the spread of spilled oil through early detection. It would be economically unreasonable to require monitoring devices at all transfer facilities. For the relevant regulations, see 33 CFR 154.525.

---

**SECTION B: DOMESTIC INSPECTION PROGRAMS****CHAPTER 6: POLLUTION PREVENTION****14. Small Discharge Containment**

The goal of this regulation is to control small leaks at connecting points until emergency shutdown or proper removal is possible. Containment under the entire hose is not required or intended. The blanking of a hose until it is connected, and the use of hoses complying with 33 CFR 154.500 requirements, should prevent most over-water spills. For the relevant regulations, see 33 CFR 154.530.

---

**15. Discharge Removal**

The optimum arrangement for discharge removal is a fixed drain system to remove discharges and normal precipitation from the facility. In general, the system should be either mechanically operated or gravity operated. The phrase "safely and quickly" must be considered relative to the products involved. This regulation is intended to keep large surface areas of highly volatile products, such as gasoline, from forming, and to provide a means to drain precipitate or other liquids from the containment so that the required capacity is available during the transfer. In the case of a portable containment system, its potential weight when full must be considered, and provisions must be made for emptying it. A system is unacceptable if the most likely action by the owner/operator is to drain the container into the water. For the relevant regulations, see 33 CFR 154.540.

---

**16. Discharge Containment Equipment**

- a. Pre-transfer booming. Only unusual situations require pre-transfer booming, and COTP interpretation of this regulation should be fairly uniform.
  - (1) The authority to require containment to be deployed before the transfer is mentioned specifically in this regulation, because in some cases it is the only practical way to protect the environment from particularly risky transfer operations.
  - (2) For the relevant regulations, 33 CFR 154.545.
- b. Time limits. Under 33 CFR 154.545(c), time limits for gaining access to oil spill containment materials must be set by the owners/operators of the facilities, subject to approval by the COTP.
  - (1) The operator must take currents into account when establishing time limits for boom deployment. Although booms may not contain oil when deployed in rapid currents, they may be effective in channeling its movement, and thus protect some areas from damage.



**SECTION B: DOMESTIC INSPECTION PROGRAMS****CHAPTER 6: POLLUTION PREVENTION**

- (2) This helps ensure that equipment sharing agreements among facility owners/operators are realistic and provide for adequate response to oil discharges.
- c. Equipment. Each facility must have containment equipment available, whether by direct ownership, membership in a cooperative, or prearrangement with commercial interests.
- (1) Shared or contracted equipment must be located so that it can be brought on scene in a timely manner. The determination of location and timeliness should reflect local conditions; in current or tidal areas, the time to deploy will generally be less than that allowed for still water areas.
- (2) In locations adjoining ecologically sensitive areas, booms may need to be set in place for each transfer operation.
- (3) Each facility should be prepared to contain and remove a discharge in accordance with these regulations, the National Contingency Plan (NCP), and 33 CFR Part 153.

---

**17. Emergency Shutdown 33 CFR 154.550**

- a. Facility to vessel. 33 CFR 154.550 applies specifically to the transfer of oil from facility to vessel. As the PIC on the vessel must be able to stop loading immediately in the event of manifold valve failure, hose failure, or overfill, the emergency shutdown mechanism should normally be located aboard the vessel.
- (1) The accessibility of the shutdown mechanism is one factor the COTP will consider when authorizing single operator transfers.
- (2) See 33 CFR 156.115 for the relevant regulation.
- b. Alternative measures. In the event that the PIC on the vessel does not remain near the usual operating station where the shutdown controls are located, acceptable alternative measures must be provided to maintain the emergency shutdown capability. Acceptable alternatives must provide for continuous dedicated communications. An audible alarm system is not acceptable.
- c. Flow closure devices. The flow closure devices actuated by the shutdown system must be located on the facility side of the hose. If their use may cause hydraulic shock to the system, the system must be capable of withstanding such shock loading. Proper closure sequencing of pumps and valves may be necessary (e.g.,

**SECTION B: DOMESTIC INSPECTION PROGRAMS****CHAPTER 6: POLLUTION PREVENTION**

the pumps must be stopped prior to closing the pipeline to prevent rupture), and is certainly not precluded, provided the applicable time limit is met.

---

**18. Communications 33 CFR 154.560**

- a. Two-way communications. Adequate communication between the vessel and the facility is essential to coordinate control of the transfer operation.
- (1) Two-way voice communications enable each PIC hear the other.
  - (2) In the event that the PICs are not close enough to be easily and readily heard by voice alone, the facility must provide an effective means of communications.
  - (3) For single operator transfers and at facilities with low ambient noise levels, an electronic or sound powered system may not be necessary. Consideration must be given, however, to the probable location of personnel during various stages of transfer operations and in inclement weather, to ensure that two-way communications are possible.
- b. Intrinsically safe radio devices. Radio devices used to comply with this regulation must be approved as intrinsically safe by either Underwriters Laboratories, Inc. (UL), Factory Mutual Research Corporation (FM), Canadian Standards Association (CSA), or MET Testing Company (MET). Intrinsically safe radios are not required on vessels certificated to carry and carrying only Grade E liquid cargoes.
- 

**19. Lighting 33 CFR 154.570**

Adequate lighting is a prerequisite for any nighttime operation. Objective standards are needed where the COTP doubts the adequacy of lighting. Specific testing is only necessary when lighting appears inadequate to the COTP (i.e., a flashlight should not be necessary to conduct operations effectively). At small or remote facilities, where portable lights are used or illumination is provided by a tug, the shielding of lights must be specified in the operations manual and in the written directions for transfer operations.

---

---

## SECTION B: DOMESTIC INSPECTION PROGRAMS

## CHAPTER 6: POLLUTION PREVENTION

**D. REQUIREMENTS FOR VESSELS (33 CFR PART 155)****1. Applicability 33 CFR 155.100**

- a. Introduction. U.S. vessels must meet the applicable requirements of 33 CFR Part 155 to be issued a COI under the applicable subchapters of Title 46 CFR.
- (1) Public vessels that would otherwise be exempt from compliance must meet these requirements if they are to be certificated by the Coast Guard. These include vessels operated as maritime school ships and vessels of the Navy's Military Sealift Command (MSC).
  - (2) Consequently, a vessel's COI will be accepted as evidence that it is in compliance with 33 CFR Part 155.
- b. International Oil Pollution Prevention (IOPP) Convention Certificate. Foreign and U.S. ships are required to be surveyed for compliance with MARPOL 73/78. An IOPP Certificate, CG-5352 with the applicable IOPP Supplement Form A, CG-5352A or IOPP Supplement Form B, CG-5352B will be accepted as evidence that the vessel complies with 33 CFR Part 155 pollution prevention requirements.
- c. Enforcement. Primary responsibility for enforcing the regulations for public vessels rests with the Federal agency owning and operating the vessel, not with the Coast Guard. However, consistent with its general enforcement responsibility and in the public interest, the Coast Guard will do the following:
- (1) Assist the efforts of the Federal owner/operator of a public vessel certificated by the Coast Guard to comply with the pollution prevention regulations by providing information and advice.
  - (2) Conduct inspections and monitor transfer operations on board such a vessel only when requested and approved by the cognizant Federal agency, or during renewal of the COI.
  - (3) Advise other agencies of violations, when observed or reported, and of requirements that must be met to achieve compliance.
- d. When a violation is observed on a certificated public vessel, the COTP must:
- (1) Formally advise the responsible official of the violations;
  - (2) Explore all possible means of resolving the matter and achieving compliance; and,

## SECTION B: DOMESTIC INSPECTION PROGRAMS

## CHAPTER 6: POLLUTION PREVENTION

- (3) Submit relevant documentation to the district commander for disposition if compliance is not forthcoming.
- e. Upon receipt of documentation from the COTP, the district commander must explore all possible means of reaching mutual agreement to achieve compliance. If this fails to resolve the situation, forward all relevant information to Commandant (CG-5P) for resolution with the parent agency.
- f. Tank barges. Tank barges inspected under 46 CFR Subchapter D (Tank Vessels) or 46 CFR Subchapter O (Certain Bulk Dangerous Cargoes) for the carriage of flammable or combustible cargoes that are not considered oil need not meet the requirements of 33 CFR Part 155. In such cases, the COI should be endorsed "33 CFR 155 need not be complied with unless oil is carried." Oceangoing tank barges over 150 GT must meet the survey requirements and be issued an IOPP Certificate, CG-5352 with IOPP Supplement Form B, CG-5352B attached.
- g. Permanently moored craft. For the purposes of the regulations, a craft that is permanently moored at a fixed location, so as to be "substantially a land structure" and "does not have a practical use for transportation on the water," may be considered an integral part of the facility, or work platform. So as not to be subject to the provisions of 46 U.S.C. 3701, the craft must meet the requirements of Chapter B.4 of this Manual.
- h. Vessels with containment systems. The inspection provisions do not apply to floating vessels that have flammable or combustible liquids within a containment system installed solely for compliance with 33 CFR 154.530 when such liquids would be routinely discharged to the shoreside part of the facility.
- i. Floating non-tank vessels with containment systems only will not be subject to inspection under 46 U.S.C. Chapters 33 and 37. However, all on board components of such vessels, including piping, collection and holding tanks, vents, and pumps must be examined for safety and satisfactory operation as part of the facility examination referred to in 33 CFR 154.120.

---

## 2. Definitions 33 CFR 155.110

MARPOL 73/78 operational and equipment requirements center on whether the ship is "oceangoing" and a "new ship" or an "existing ship."

- a. Oceangoing. A U.S. oceangoing ship is a vessel that is certificated for ocean service or that operates at any time beyond the U.S. territorial sea. All foreign ships are oceangoing,

**SECTION B: DOMESTIC INSPECTION PROGRAMS****CHAPTER 6: POLLUTION PREVENTION**

except those operated exclusively within the Great Lakes or Puget Sound or their connecting and tributary waters.

**NOTE:** Check the applicability section of the regulations for a particular vessel type (i.e. tank vessel, OSV, small passenger vessel, etc.).

- b. New or existing ship. Three dates are key to determining a vessel's status as new or existing: the vessel's contract date, keel-laying date, and delivery date.
- (1). Ships with either a delivery date after 31 December 1979 or a contract date after 31 December 1975 are considered new.
  - (2) If the contract date is unavailable, the keel-laying date must be obtained from the ship's International Convention for the Safety of Life at Sea (SOLAS) Safety Construction Certificate. If the keel-laying date is after 30 June 1976, the ship is new.
  - (3) If the ship's owner/operator provides documentation that the ship's contract date was before 31 December 1975, the ship is considered existing, as the contract date takes precedence over the keel-laying date.
  - (4) A determination by a party nation on a specific ship's status under MARPOL 73/78 should be accepted by the local unit.
  - (5) The local unit must accept a party nation's determination as to whether a ship conversion is major or minor. In the absence of such a determination, the COTP should apply the definitions and interpretations in MARPOL Regulation 1.
  - (6) If an obvious error has been made concerning a vessel's status, the COTP should contact Commandant (CG-FAC).

---

**3. Equivalents 33 CFR 155.120**

Equivalents for MARPOL 73/78 requirements are only granted by Commandant (CG-5P) . MARPOL 73/78 disallows the substitution of operational methods to control the discharge of oil for a design construction feature. The equivalents granted by the United States are contained in enclosure (7) of Commandant Instruction (COMDTINST) M16450.26. Equivalents allowed by foreign countries and acceded to by the United States are contained in enclosure (8) to COMDTINST M16450.26. Refer questions concerning equivalents to Commandant (CG-FAC). It should be noted that, for vessels operating exclusively in U.S. domestic service for which the oil transfer procedures call for the use of an equivalent shore

**SECTION B: DOMESTIC INSPECTION PROGRAMS****CHAPTER 6: POLLUTION PREVENTION**

connector, a 1.5-inch quick connect fitting is permitted. This equivalence does not apply to vessels in international service or to oceangoing vessels of 400 or more GT.

---

**4. Exemptions 33 CFR 155.130**

When appropriate, exemption requests forwarded to Commandant (CG-5P) must include observations or assessments of the situation from the COTP. These will aid in determining whether or not to grant an exemption. Exemption requests must be forwarded to the Commandant only when all means of alternative compliance have been exhausted.

---

**5. Cargo Oil Discharge Containment 33 CFR 155.310**

a. General provisions. 33 CFR 155.310 clarifies the containment requirements for hoses and loading arms and to require the specified capacity in all conditions of vessel list or trim during the transfer operation.

- (1) Only barges have the option to use a coaming in lieu of a large containment system. This option exists because the deck construction on many barges makes large, fixed containment impractical or unsafe. Generally, however, coamings installed around the periphery of a vessel should not be allowed in lieu of containment.
- (2) The safety problems in utilizing the total deck enclosure for containment include conditions of list or trim, rain accumulation, required methods of product removal, fire hazards, structural considerations, and personnel safety. A coaming that is used in lieu of a fixed containment system must be able to keep spilled oil within the coaming and portable containers until properly drained or removed, without discharge into the water.

b. Drainage.

- (1) Acceptable mechanical means of drain closures include valves, threaded caps or plugs, or solid stoppers (e.g., rubber plugs) in conjunction with concrete (provided the concrete remains sound.) Concrete, plastic or wooden plugs alone, or rags in any fashion, are unsuitable. The present requirements of 46 CFR 35.35-10 for plugging general deck scuppers remain valid.
- (2) Drainage installations should be compatible with existing regulations, which require a check valve in the drain line if flammable liquids are carried and there is a direct connection of the line to a cargo tank.
  - (a) Drains need not be piped to cargo tanks.

**SECTION B: DOMESTIC INSPECTION PROGRAMS****CHAPTER 6: POLLUTION PREVENTION**

- (b) Alternative means of containment drainage must not create a potential for discharge. A drainage system will not be accepted when the most likely result is discharge of oil into the water or the bilges of auxiliary spaces, or the mixing of incompatible products.
- (c) Use of collection tanks is encouraged; pumping of contained oil into portable drums or containers is discouraged. Arrangements between the vessel and the facility for removal of oil spilled into containment systems must be undertaken in a timely manner.

---

**6. Fuel Oil and Bulk Lubricating Oil Discharge Containment 33 CFR 155.320**

- a. Applicability. 33 CFR 155.320 requires containment when lube oil is transferred and carried in bulk as stores for consumption by the vessel. This section generally applies to the area immediately surrounding the fueling station and associated vents. It does not apply to--
  - (1) The vent header system;
  - (2) Flush deck fittings, even though they are raised slightly off the deck to prevent the entry of water; and
  - (3) Vents for small, independent, auxiliary fuel tanks, such as used on barges for pump drive engines, when the tank is designed to be filled with a back flow shut-off nozzle or similar arrangement.
- b. 33 CFR 155.320 applies to fuel tank vents fitted with goosenecks as opposed to straight-type vents, which are common on foreign vessels. Most straight-type vents will discharge oil in a 360-degree horizontal pattern that rules out the use of portable containers. Using the bulwarks to keep the oil on the vessel and relying on coamings or plugged scuppers to contain the discharge is unacceptable. Generally, straight vents will require fixed containment around the vent head or modification of the vent itself.
- c. Piping arrangements. Unusual or complex piping arrangements on existing vessels need not be retrofitted if, in fueling the vessel, an equivalent level of protection can be demonstrated (see 33 CFR 155.
  - (1) For example, regulations suggest the use of external containers. However, devices built into a vent line or a system to contain the required amount of oil, while still permitting the vent to function, will satisfy these requirements. Vent header systems that lead to a final tank for containment are also acceptable.

**SECTION B: DOMESTIC INSPECTION PROGRAMS****CHAPTER 6: POLLUTION PREVENTION**

- (2) Alternative procedures, methods, or equipment standards must be clearly explained in the oil transfer procedures for the vessel.
- (3) This requirement for containment under fuel oil and bulk lubricating vents does not apply to fixed or floating drilling rigs and other platforms.

**NOTE:** Such devices must be brought to the attention of marine chemists and must be capable of gas-freeing.

- d. Capacity requirements. In general, the capacity of the required fixed discharge containment for fuel oil and bulk lubricating oil vents, overflows, and fill pipes is the volume as specified in 33 CFR 155.320, for each vent, overflow, etc. On some cases, one fixed discharge containment may suffice for more than one such vent, overflow, or fill pipe.
  - (1) In determining whether the required capacity for a single fixed containment is adequate for a group of vents, overflows, or fill pipes, the distance between the individual devices must be considered along with the location of associated tanks, related piping configurations, etc.
  - (2) The final containment design must ensure that containment provided for a group of vents, overflows, etc., has the capability to retain expected discharges.

---

**7. Bilge Slops/Fuel Oil Tank Ballast Water Discharges Aboard U.S. Non-Oceangoing Ships 33 CFR 155.330**

- a. Oily wastes and bilge slops. Most vessels have a waste or slop oil tank. All vessels must have the ability to retain oily waste and oily bilge slops aboard.
  - (1) Use of the bilge itself is acceptable on vessels that have essentially dry bilges, which collect only small quantities of machinery oil drippings.
  - (2) Vessels with wet bilges that are essentially oil-free need not provide a special tank for bilge water disposal. Such arrangements in no way constitute an exemption from assessment of a penalty for discharging a harmful quantity of oil.
- b. Discharge of oily wastes and bilge slops. Proposals to pump oily wastes and oily bilge slops to fuel tanks or ashore through the bunkering lines have been accepted when proper safeguards have been incorporated.



**SECTION B: DOMESTIC INSPECTION PROGRAMS****CHAPTER 6: POLLUTION PREVENTION**

- (1) The acceptance of such proposals has raised questions regarding the applicability of 46 CFR 56.50-50(h). 46 CFR 56.50-50(h) may be revised to permit the discharge of oily wastes and bilge slops to fuel tanks and tanks ashore through bunkering lines.
- (2) The system must be arranged to preclude the discharge of fuel into the bilge system. Normally, double-check valves (one of these being a stop check valve) will be required between the bilge pump discharge and the bunkering line or fuel tank. The discharge to the fuel tank must enter at the top of the tank, if possible.
- (3) The requirement to have an oily residue (sludge) tank does not apply to non-oceangoing U.S. vessels.

---

**8. Bilge Slops/Fuel Oil Tank Ballast Water Discharges on Oceangoing Ships of Less Than 400 GT 33 CFR 155.350**

Ships in this category must either retain all oily mixtures aboard and be equipped to discharge them to a reception facility, by fixed or portable means, or have approved oily-water separating equipment. Commandant (CG-CVC-2) should be contacted to verify that an Oily-Water Separator (OWS) has been approved by the International Maritime Organization (IMO). Ships in this category are not required to have a bilge alarm or bilge monitor installed. Ships failing to have the applicable equipment aboard should be processed for civil penalty assessment. For vessels with separating equipment installed but inoperative, civil penalty proceedings should be used if reasonable efforts have not been made to make repairs. The ship should be detained in port until the discrepancy is corrected.

- a. U.S. self-propelled ships of less than or equal to 400 GT. U.S. self-propelled ships of less than or equal to 400 GT may retain all oily mixtures on board in the ship's bilges. An oily residue (sludge) tank is not required.
- b. Non-self-propelled ships with auxiliary machinery of less than 2,000 Horse Power (HP). Non-self-propelled vessels outfitted with machinery of less than 2,000 HP typically do not present a significant risk of oil pollution from the machinery space bilges. These vessels are not usually fitted with a large number of through-hull fittings. These types of vessels generally do not employ large amounts of water for cooling and steam plant operation. Therefore, these vessels usually have a minimal amount of water in their bilges.
- c. Equivalency. An equivalency has been established between a non-self-propelled barge with installed auxiliary machinery and a total output of less than 2,000 HP in spaces protected by bilge pumping and a self-propelled ship of 400 GT or less.

**SECTION B: DOMESTIC INSPECTION PROGRAMS****CHAPTER 6: POLLUTION PREVENTION**

- (1) Barges eligible for the equivalency need not have OWS if they comply with the requirements set forth in 33 CFR 155.420(a) for oily bilge slop retention and shore discharge pumping, piping, and discharge connections for oceangoing ships of less than 400 GT but greater than or equal to 100 GT.
- (2) As required by 46 CFR 56.50-5(e), drip pans must also be installed on inspected vessels under any equipment subject to normal oil leakage.
- d. Equivalency requests for barges should be evaluated for eligibility under approved equivalency for barges with auxiliary machinery with a total output of less than 2,000 HP. The OCMI may authorize an eligible barge for which the owners choose not to install an OWS, to be operated in accordance with the approved equivalency by making the following entry in paragraph 6.1 of the IOPP Supplement Form A, CG5352A (or Paragraph 10.1 of IOPP Supplement Form B, CG-5352B, if applicable): “2.2, 2.3, and 3 - the machinery space pollution potential of this vessel is equivalent to that of ships of less than 400 gross tons. The vessel is therefore outfitted to comply with the requirements of Regulations 9(2). All oil and oily wastes must be retained on board for discharge to reception facilities.”

---

**9. Bilge Slops Discharges- Oceangoing Ships Greater than 400 GT, but less than 10,000 GT, Excluding. Ships That Carry Ballast Water in Their Fuel Oil Tanks**

Oceangoing ships greater than 400 GT, but less than 10,000 GT, excluding. ships that carry ballast water in their fuel oil tanks must have, at a minimum, an OWS capable of producing an effluent of less than 100 ppm of oil. They must also have a tank for oily residues (sludge) that cannot be handled through the OWS. Additionally, these vessels must have pipelines installed for the discharge of oily mixtures to waste reception facilities. For the relevant regulations, see 33 CFR 155.360.

---

**10. Bilge Slops/Fuel Oil Tank Ballast Water Discharges on Oceangoing Ships greater than 10,000 GT, and Oceangoing Ships greater than 400 GT That Carry Ballast Water in Their Fuel Oil Tanks**

Oceangoing ships greater than 10,000 GT and oceangoing ships greater than 400 GT that carry ballast water in their fuel oil tanks must also have an approved bilge monitor or alarm in addition to an approved OWS. If the vessel owner chooses a system with an approved bilge monitor, the continuous monitor record must be maintained aboard the vessel for three years from the date of the last entry on that record. For the relevant regulations, see 33 CFR 155.370.

---

**SECTION B: DOMESTIC INSPECTION PROGRAMS****CHAPTER 6: POLLUTION PREVENTION****11. OWS Equipment, Bilge Alarm, and Bilge Monitor Approval Standards**

Commandant (CG-CVC-2) should be contacted when there is a question concerning such equipment approved by the IMO. For the relevant regulations, see 33 CFR 155.380.

---

**12. Pumping, Piping, and Discharge Requirements for Oceangoing Ships of Greater Than 100 GT but Less Than 400 GT**

This regulation requires a means on the weather deck of near the discharge outlet to stop each pump that is used to discharge oily wastes. This requirement applies to oceangoing ships of greater than 100 GT but less than 400 GT and may be satisfied by an installed pressure switch that shuts down the pump that is discharging oily wastes when the stop valve is closed. For the relevant regulations, see 33 CFR 155.420.

---

**13. Placard**

The placard must be posted as specified in 33 CFR 155.450 in any machinery space that generates or collects oily waste (e.g., auxiliary spaces on unmanned barges). Pleasure boats 26 feet or more in length must also comply with this provision.

---

**14. Prohibited Oil Spaces**

33 CFR 155.470 applies to all self-propelled vessels. Where collision bulkheads are not fitted, the requirement applies to the forward most continuous bulkhead.

---

**15. Designation of PIC**

The vessel operator or his or her agent must designate in advance, individuals who may serve as PICs; a current list of such individuals should be available. The person who signs the Declaration of Inspection (DOI) described in 33 CFR 156.150 is the PIC until his or her relief signs the DOI. For the relevant regulations, see 33 CFR 155.700.

---

**16. Oil Transfer Procedures**

33 CFR 155.720 requires that written directions for oil transfer operations be aboard whenever the vessel is in service, although they are only used during transfer operations.

**SECTION B: DOMESTIC INSPECTION PROGRAMS****CHAPTER 6: POLLUTION PREVENTION**

33 CFR 155.720(b) was added because the Coast Guard has documented spills from fuel day tank transfers, cargo tank transfers, and other internal vessel transfers. The Pollution Incident Reporting System (PIRS) documented approximately 140 spills per year from such transfers from 1973-1977. The written procedures for internal vessel oil transfers need not be as complex as those for cargo or fuel transfers to a facility or another vessel; however, they should be available for reference before and during internal transfers. For the relevant regulations, see 33 CFR 155.720.

---

**17. Availability of Oil Transfer Procedures 33 CFR 155.740**

- a. General. The goal of 33 CFR 155.740's requirements is to ensure that vessel personnel involved in oil transfer operations know the necessary procedures, regardless of language differences. All procedures must be legibly printed in a language understood by personnel engaged in transfer operations.
- (1) Vessel owners and operators may decide what crews to hire, but whoever supervises the transfer must be able to perform with minimal risks of pollution.
  - (2) Transfer procedures need not be posted on unmanned tank barges, but must be readily available to transfer personnel.
  - (3) On tank vessels, detailed data and procedures need not be permanently posted, but must be kept aboard the vessel in a place that is accessible to personnel involved in the transfer.
- b. Posted procedures. Directions for transfer operations, which must include the information required by 33 CFR 155.750, should be written to be posted; no separate manual is necessarily required.
- (1) Such directions are not intended as training manuals for tankermen, but they must explain any abnormal or complicated instructions so that the transfer system may be operated safely.
  - (2) On an unmanned tank barge, for example, a simple line drawing of the piping arrangement showing any unique features and properly labeled, may suffice.
  - (3) Emergency phone numbers must also be included in these procedures.
-

**SECTION B: DOMESTIC INSPECTION PROGRAMS****CHAPTER 6: POLLUTION PREVENTION****18. Contents of Oil Transfer Procedures 33 CFR 155.750**

33 CFR 155.750 requires detailed information for the oil products transferred to or from a vessel. The regulation's intent is to ensure that the pollution prevention regulations are applied to all oil products transferred in bulk. Tank barges have had difficulty keeping oil cargo information on board due to space limitations. This is also because 33 CFR 155.750(a)(1) has been strictly interpreted to require a separate cargo information card for each cargo for which the barge is certificated. As 33 CFR 155.750 is intended to ensure the tankerman or PIC has information on the hazards and correct handling of the products he or she is handling, information cards for product transferred to or from the vessel are required. Cargoes with similar characteristics can be listed together on one information card for convenience; however, those cargoes with significantly different characteristics (such as different grades) should be listed separately. Marine safety personnel should--

- a. Point out essential cargo information, such as special hazards, if the cargo is different from oil, and procedures for oil spills;
- b. Allow summary data where feasible; and
- c. Allow revision of the procedures under 33 CFR 155.760 when legitimate problems arise in existing procedures.

---

**19. Emergency Shutdown**

33 CFR 155.780 addresses the transfer of oil from a vessel to a facility or to other vessels. Installation of additional remote shutdown stations may be necessary, depending upon the movements of the PIC during the transfer. In lieu thereof, consideration may be given for use of appropriate portable radio communications between the PIC and the crewmember located at the remote shutdown station.

---

**20. Communications**

33 CFR 155.785 requires continuous communications with all parties involved with the transfer operation to ensure that rapid shutdown of an oil transfer is possible. Voice communications may not be sufficient, due to ambient noise levels in the area or distance between PICs.

---

**SECTION B: DOMESTIC INSPECTION PROGRAMS****CHAPTER 6: POLLUTION PREVENTION****21. Deck Lighting**

To ensure pollution-free operation, the vessel is responsible for providing illumination consistent with the requirements of 33 CFR 154.570. The adequacy of existing vessel cargo deck lighting will normally be determined by practical demonstration. Verification by instruments may be required in questionable instances. For the relevant regulations, see 33 CFR 155.790.

---

**22. Tank Vessel Security**

Notwithstanding the provisions of 46 CFR 35.05-15(b), moored tank barges must be kept under surveillance when they are not gas free. Boarding officers must assess each situation to ensure that local procedures satisfy the requirement for vessel security in the particulars of mooring/berthing facilities, location of personnel acting as watchmen, environmental considerations, and other factors. For the relevant regulations, see 33 CFR 155.810.

---

**23. Tank Vessel Integrity**

The openings listed in the regulation must be tightly shut, except as allowed by 33 CFR 155.815(b), to prevent the entry of water or loss of oil. Tank vessels with oil cargo or oil residue aboard while in U.S. navigable waters or the contiguous zone must comply with 33 CFR 155.815. Tank vessels that are gas-freed are not covered by 33 CFR 155.815. For the relevant regulations, see 33 CFR 155.815.

---

**24. Records**

Records that must be maintained and "available for inspection by the COTP or OCMI" must be readily available to Coast Guard personnel. In the case of unmanned tank barges, such records will generally be kept with the vessel's COI. The licensed officer or certificated tankerman required by 33 CFR 155.700 who will conduct the transfer operation in each locale must be listed in the records. For the relevant regulations, see 33 CFR 155.820.

**SECTION B: DOMESTIC INSPECTION PROGRAMS****CHAPTER 6: POLLUTION PREVENTION**

---

**E. REQUIREMENTS FOR TRANSFER OPERATIONS INVOLVING VESSELS (33 CFR PART 156)**

---

**1. Applicability**

Government-owned vessels engaged in commerce are subject to the requirements of 33 CFR Part 156. Other public vessels are usually required by agency guidelines to meet or exceed the requirements of 33 CFR Part 156.

Transfers of oil to, from, or within a vessel are regulated if the vessel has a capacity of 250 barrels or greater of that oil (including internal fuel and lube oil transfers, which have been the source of numerous spills in the past).

The word "that" is emphasized to draw attention to its presence in 33 CFR 156.100 (also 33 CFR 154.100). This regulation is not meant to apply to a vessel with a cumulative on board capacity of 250 or more barrels of oil, but rather to vessels with an on board capacity of 250 or more barrels of a specific type of grade of oil.

For the relevant regulations, see 33 CFR 156.100.

---

**2. Suspension Orders**

33 CFR 156.112 allows for issuance of rapid suspension orders when conditions threaten an imminent discharge of oil.

33 CFR 156.112 allows for the suspension of transfer operations if Coast Guard personnel are not allowed access to inspect the operation to verify compliance.

The COTP or OCMI must be advised immediately of any action to suspend a transfer operation (in most cases, he or she is consulted prior to any suspension order). In any event, the operator is free to immediately contact the COTP or OCMI to question the suspension order or to advise of corrective action to have the order lifted.

For the relevant regulations, see 33 CFR 156.112.

---

## SECTION B: DOMESTIC INSPECTION PROGRAMS

## CHAPTER 6: POLLUTION PREVENTION

**3. PICs: Limitations 33 CFR 156.115**

- a. The facility and each vessel involved should have a PIC during an oil transfer unless the COTP determines that there is no increased risk of pollution in single-operator transfers involving more than one vessel.
- b. When determining whether to grant a request for a single-operator transfer, the COTP should consider the following:
  - (1) Under specified or controlled conditions, can one person effectively perform all required operations at the facility in question?
  - (2) How complex is the operation? What degree of mechanization is available to assist the operator?
  - (3) Can one PIC operate the emergency shutdown for each transfer and respond to spills adequately?
  - (4) What has been the past performance of the facility?
- c. Mooring two adjacent barges manifold-to-manifold may be an acceptable arrangement for a single-operator transfer, mooring them end-to-end, which places the manifolds a considerable distance apart, may be unacceptable (see Paragraph 31.C.17 above). Such requests should not be referred to Commandant (CG-5P) as exemption requests under 33 CFR 156.110.

---

**4. Requirements for Oil Transfer**

- a. General. Vessel and facility owner/operators are responsible for the actions or inactions of their employees. It is also the vessel and facility owner/operator's responsibility to train personnel and ensure their compliance with safety and environmental standards. Because personnel error is a predominant cause of oil spills, training and personnel compliance are essential to any pollution prevention program. For the relevant regulations, see 33 CFR 156.120.
- b. Vessel moorings (33 CFR 156.120(a)). The intent of this CFR paragraph's requirements is for mooring lines to be regularly checked throughout the transfer operation, to prevent the parting of hoses that could lead to an oil spill.
  - (1) If the PIC of a vessel or facility is not satisfied with the intended operation at the pretransfer conference, the transfer must not proceed until such time as the process is clearly understood and accepted.



**SECTION B: DOMESTIC INSPECTION PROGRAMS****CHAPTER 6: POLLUTION PREVENTION**

- (2) In crew or watch changes during cargo transfers, the oncoming crewmember should ensure that all provisions of the DOI are being met; when he or she signs the form, he or she becomes the PIC.
- c. Fixed and portable transfer systems. 33 CFR 156.120(g)
- (1) Due to static electricity combustion hazards produced by free-falling Grade D and E cargoes and the health hazard from fumes posed to personnel in the cargo hold above the deep tank, loose hose transfers over hatch tops are not permitted.
- (2) The term "fixed connection" means the fixed cargo piping system installed on the vessel. In cases where the fixed cargo piping system does not exist, or where it is impossible or undesirable to use this system, the COTP should consider granting an alternative under 33 CFR 156.107 to allow use of a portable transfer system. This system should consist of the following:
- (a) A hose that meets the requirements of 33 CFR 154.500 or portable piping that meets the requirements of 46 CFR Part 56.
- (b) Connections that meet the requirements of 33 CFR 156.130.
- (c) A closure, such as a manhole cover, Butterworth plate, or flange; or deepwell pump stack that forms a vapor tight seal over the opening in the tank top through which the cargo is transferred. This closure should be bolted or dogged in place, and the hose and drop line should be connected to it.
- (d) A metallic drop line that meets the requirements of 46 CFR 153.282 (not necessary for transferring Grade E, edible, vegetable, or animal oils).
- (e) A drip pan of at least 1/2-barrel capacity under each connection on the weather deck or ashore.
- (f) A shutoff valve at or near the point of entry into the tank.
- (3) The alternative of a portable transfer system should be restricted to transfers of Grade D and E cargoes. However, approval has previously been given by Commandant (CG-ENG) to certain parcel chemical tankers for transfer of cargo by this method. Continued acceptance should be considered for such vessels.

**SECTION B: DOMESTIC INSPECTION PROGRAMS****CHAPTER 6: POLLUTION PREVENTION**

- d. Securing of certain discharge and sea suction valves. 33 CFR 156.120(h) prohibits simultaneous cargo transfer and ballasting or deballasting of cargo tanks, except for specific circumstances set forth in 33 CFR Part 157 that are consistent with MARPOL 73/78. These are--
- (1) Ballasting or deballasting of Segregated Ballast Tanks (SBTs) because the pump and piping system are separate from the cargo system;
  - (2) Ballasting or deballasting of dedicated Clean Ballast Tanks (CBTs), in accordance with 33 CFR 157 or where an independent ballast system for CBTs is installed; and,
  - (3) Simultaneous ballasting and cargo discharge, in accordance with 33 CFR Part 157, to prevent hydrocarbon vapor emissions on a tank vessel with a Crude Oil Washing (COW) system. The goal is to prevent accidental mixing of ballast water and cargo oil or loss of oily mixtures to the water.
- e. Hose requirements. According to 33 CFR 156.120(j), if the first fabric layer (the "breaker" layer) is loosely woven and primarily intended to aid in bonding the cover to the rest of the hose, it is not considered a reinforcement layer. Hose repairs are allowed, provided the reinforcement is not penetrated, there are no leaks, and the repaired hose meets the testing requirements in 33 CFR 156.170.
- f. Emergency shutdown mechanism. 33 CFR 156.120(r) is meant to ensure that the equipment is operable. This does not always require triggering the device.
- g. Duties of personnel. 33 CFR 156.120(t)(1) clarifies that the PIC must be able to supervise all personnel during transfer operations.
- (1) "At the site", as it is used in 33 CFR 156.120(t)(1), means that the transfer point is in view and that the PIC is in a position to supervise the overall transfer operation and to respond to emergencies immediately.
  - (2) The requirements in 33 CFR 156.120(t) and (u) may appear similar but are not redundant. 33 CFR 156.120(t) applies to the PIC, while 33 CFR 156.120(u) requires all personnel on duty to comply with transfer guidelines. However, if a PIC is engaged in a single-operator transfer, he or she must comply with the requirements of both 33 CFR 156.120(t) and (u).
  - (3) In making crew or watch changes, oncoming crewmembers must ensure that all provisions of the DOI are met. By signing the DOI, the oncoming PIC assumes responsibility for the transfer from that point on.

**SECTION B: DOMESTIC INSPECTION PROGRAMS****CHAPTER 6: POLLUTION PREVENTION**

- h. Communications. 33 CFR 156.120(v) does not require PICs to speak English, but it does require these persons to be able to speak to each other directly or through an interpreter who is continually present (this assumes that each, in turn, can communicate with his or her subordinates).
- 

**5. Discharge Cleanup**

The goal of 33 CFR 156.125 is to control the spread of oil and to check its source before resuming transfer operations. COTP authorization is required for resumption of normal transfer operations but not for the removal of discharged oil from the water and its return to proper storage. As long as removal by the spiller is performed properly, the COTP will not interfere in the cleanup operations. There should be no spills or leaks in the work area during transfer operations. A leak into containment devices is not considered a discharge into the water; stopping a leak without halting the transfer may be sufficient. However, the specified containment capacity must be available throughout the transfer operation.

---

**6. Declaration of Inspection (DOI)**

33 CFR 156.150(f) requires operators of vessels and facilities to keep a copy of the DOI aboard for one month. When vessels (particularly unmanned barges) operate in a relatively limited area and conduct many transfers per month, so that unreasonably large numbers of DOIs would accumulate, the COTP may permit the vessel operator to keep only the DOI from the last transfer aboard. In most cases, the COTP will be concerned only with the most recent transfer that may have caused a spill. If more information is required, the facility copy of the DOI is available for one month (in all but vessel-to-vessel transfers). Should a problem arise with a particular vessel, the COTP should monitor the vessel's operations directly, rather than rely upon the DOI, to verify routine compliance. The requirements of 46 CFR 35.35-30 will be revised to ensure compatibility with the DOI requirements of 33 CFR 156.150. The ship/shore safety checklist from the International Oil Tanker and Terminal Safety Guide, sufficiently expanded to include the requirements of these regulations, is acceptable. For the relevant regulations, see 33 CFR 156.150.

---

**7. Supervision By PIC**

If the PIC must use a shelter during transfer operations in bad weather, the shelter must allow proper observation and supervision of the transfer and unimpeded operation of the emergency shutdown mechanism. For the relevant regulations, see 33 CFR 156.160.

---

**8. Equipment Tests and Inspections**

**SECTION B: DOMESTIC INSPECTION PROGRAMS****CHAPTER 6: POLLUTION PREVENTION**

- a. Introduction. The high pressure test required by 33 CFR 156.170 is intended to expose a weakness or leak under controlled conditions, so that corrective action can be taken before a spill.
- (1) Testing to 1.5 MAWP is standard engineering practice and does not damage or destroy a hose in good working condition.
  - (2) On the other hand, testing only to MAWP is not a conclusive indicator of hose condition and is not suitable to determine that a hose is safe for transfer operations.
- b. Transfer piping systems.
- (1) A vessel's oil transfer pipe system includes the discharge pump and piping or hose between the pump and the vessel's deck manifold (which connects to the facility or other vessel's transfer system). The portions of the vessel's oil transfer pipe system, not including nonmetallic hose(s), must be tested annually to a minimum of 1.5 times the MAWP of the pipe system.
    - (a) In this instance, the MAWP can be assumed to be either the pressure at which the transfer piping relief valve is set or, where no relief valve(s) are fitted, the maximum discharge pressure including hydraulic shock that can be developed by the vessel's pump.
    - (b) For centrifugal pumps, this is the pressure developed by the pump at zero flow conditions, i.e., pump shutoff head.
    - (c) All nonmetallic cargo hose(s) used on a vessel as part of its oil transfer system must also be tested to 1.5 times its MAWP, which will be a minimum of 1,552 kPa per 33 CFR 155.800 and 156.170(c)(1).
  - (2) The test pressure for facility transfer piping and loading arm(s) under 33 CFR 156.170(c)(4) is 1.5 times the MAWP.
    - (a) This test pressure may be less than 1,552 kPa if the facility operator can demonstrate to the COTP's satisfaction by written procedures in their operations manual that the facility uses an operating pressure or relief valve setting of less than 1,034 kPa.

## SECTION B: DOMESTIC INSPECTION PROGRAMS

## CHAPTER 6: POLLUTION PREVENTION

- (b) The hose that runs between the facility's manifold and the vessel's deck manifold is separate and distinct from the facility "oil transfer pipe system" and must be tested to 1.5 times the hose's MAWP but not less than 1,552 kPa. This figure represents 1.5 times a MAWP of at least 1,034 kPa, required for facility oil hose assemblies under 33 CFR 154.500.
- (c) A facility oil transfer system extends from the last valve inside the containment required by the EPA through the transfer pipe to the loading arm or manifold. (See 40 CFR Part 112.)
- c. Acceptance of alternative cargo piping test pressures for vessels. Achieving test pressures of 150% MAWP for annual cargo piping tests on tank vessels is often impractical while vessels are in service, where transfers are conducted by vacuum or suction method, or outside the shipyard where special equipment is not available. Therefore, as provided by 33 CFR 156.107, alternative test pressures of not less than 100% MAWP may be used for in-service annual cargo piping tests, provided that a 150% MAWP test of the cargo piping is conducted at least twice in any 5-year period.
- (1) The Coast Guard envisions that the 150% MAWP tests will be conducted during drydock periods at the discretion of the vessel owners or operators. Those vessels with longer drydock intervals must make arrangements to conduct the 150% MAWP tests at least twice in any 5-year period.
- (2) All alternative test pressures must provide an equivalent level of safety and protection from pollution. Accurate records of the required tests must be maintained aboard the vessel. These records must be made available to the OCM or COTP upon request.
- (3) An alternative to the 150% MAWP test of hoses should not normally be granted. Sections of piping that cannot be tested without pressurizing cargo tanks, must not be pressure tested due to the possibility of causing structural damage aboard the vessel. These sections of piping must be visually examined during periods of availability.
-

**SECTION B: DOMESTIC INSPECTION PROGRAMS****CHAPTER 6: POLLUTION PREVENTION****F. MARINE SANITATION DEVICE (MSD) REGULATIONS**

---

**1. Authority**

The EPA issued regulations on 29 January 1976 to revise federal standards for MSDs. These regulations, 40 CFR Part 140, apply to all vessels aboard which toilet facilities have been installed. Under the authority of Section 312 of the FWPCA (33 U.S.C. 1322), the Coast Guard issued regulations to implement the EPA's MSD standards on 12 April 1976. These regulations, 33 CFR Part 159, establish operating procedures and design and construction requirements for all MSD, and apply to all MSD manufacturers as well as all vessel owners and manufacturers. These regulations do not require installation of MSDs aboard vessels that have no toilets at all.

---

**2. Definition**

The term "Marine Sanitation Device" (MSD) includes any equipment for installation aboard a vessel that is designed to receive, retain, treat, or discharge sewage. It does not include portable devices (i.e., those that can be carried on and off the vessel). 33 CFR Part 159 became effective on 30 January 1977 for new vessels, and on 30 January 1980 for existing vessels (see 33 CFR 159.3 for definitions).

---

**3. State Requirements**

Vessels complying with 33 CFR Part 159 are not subject to state or local MSD requirements. However, a state may prohibit discharge of all sewage from vessels within any or all of its waters by obtaining an EPA determination that adequate shoreside facilities for the safe removal and treatment of sewage are reasonably available for such waters in which the prohibition would apply. In such waters, vessels must secure all flowthrough MSDs to prevent any discharge into the water.

---

**4. Certification of MSDs**

- a. General procedures. All MSDs must be certified by the Coast Guard.

- (1) If the MSD was built before 30 January 1976, it is considered an existing device. MSDs in this category (except no-discharge devices built before 30 January 1975) were certified by an official letter from the Commandant.

**SECTION B: DOMESTIC INSPECTION PROGRAMS****CHAPTER 6: POLLUTION PREVENTION**

- (2) No-discharge devices built after 30 January 1975 were certified by 33 CFR 159.12(b) without need for a letter; however, some manufacturers requested and received a letter in the certification process.
  - (3) Currently, if the device was manufactured on or after 30 January 1976 and is Coast Guard certified, it will have a label to this effect (except for certain no-discharge devices).
- b. **Labeling.** No-discharge devices used solely for the storage of sewage and flushwater at ambient pressure and temperature may be certified by definition. See 33 CFR 159.12(a).
- (1) Devices certified in this manner cannot be automatically labeled by the manufacturer; however, upon Coast Guard certification of the devices, labels identifying them as such may be attached.
  - (2) Such labels give the certification number and indicate whether the devices have been type-approved for inspected or uninspected vessels. See Chapter C2 of this Manual concerning inspection of MSDs.
-

**SECTION B: DOMESTIC INSPECTION PROGRAMS****CHAPTER 7: MARINE FACILITIES AND STRUCTURE****A. AUTHORITIES**

---

**1. Magnuson Act, 50 U.S.C. 191**

The Magnuson Act authorizes the safeguarding of U.S. harbors, ports, waters, vessels and waterfront facilities and all territory and water, continental or insular, subject to the jurisdiction of the United States whenever the security of the United States is endangered.

---

**2. Ports and Waterways Safety Act (PWSA) of 1972, 33 U.S.C. 1221-1232(a)**

The Ports and Waterways Safety Act (PWSA) of 1972 promotes safety and the environmental quality of ports, harbors, waterfront areas, and navigable waters of the United States (including the District of Columbia, Puerto Rico, the Panama Canal Zone, Guam, American Samoa, the Virgin Islands, and the Trust Territory of the Pacific Islands). The Secretary of Transportation has been given broad authority to take action to prevent damage to, or the destruction or loss of, any vessel, bridge, or other structure on or in U.S. navigable waters, or any land structure or shore area immediately adjacent to those waters; and to protect the navigable waters and resources therein from environmental harm resulting from vessel or structural damage, destruction, or loss. A 1986 amendment added 33 U.S.C. 1226, which provided the Secretary authority to "carry out or require measures, including inspections, port and harbor patrols, the establishment of security and safety zones, and the development of contingency plans and procedures, to prevent or respond to acts of terrorism."

---

**3. Section 311 of the Federal Water Pollution Control Act (FWPCA), 33 U.S.C. 1321**

Section 311 of the FWPCA prohibits discharges of oil or hazardous substances in quantities that may be harmful into or upon the navigable waters of the United States and adjoining shorelines. This section of the FWPCA also prohibits discharge of such quantities of oil or hazardous substances into or upon the waters of the contiguous zone, into waters connected with activities subject to the Outer Continental Shelf Lands Act (OCSLA) or the Deepwater Port Act (DPA) of 1974 or so as to affect natural resources belonging to, appertaining to, or under the exclusive authority of the United States, including resources under the Fishery Conservation and Management Act of 1976. The FWPCA directed the President to determine those quantities of oil and hazardous substances that, when discharged, may be harmful to the public health, welfare or environment of the United States. He was authorized to delegate the administration of the act to those Federal departments and agencies that he determined to be appropriate. The President delegated these functions by Executive Order (E.O.) 12777, dated 18 October 1991.

---



**SECTION B: DOMESTIC INSPECTION PROGRAMS****CHAPTER 7: MARINE FACILITIES AND STRUCTURE****4. Outer Continental Shelf Lands Act (OCSLA), 43 U.S.C. 1331-1356**

This statute, as amended, provides, in part, that the Secretary may promulgate and enforce reasonable regulations with respect to lights and other warning devices, safety equipment, and other matters relating to the promotion of safety of life and property on the artificial islands and structures located on the Outer Continental Shelf (OCS) or in adjacent waters. The Secretary has delegated this authority to the Commandant, who promulgated the safety regulations now contained in 33 CFR Parts 140-147.

---

**5. Hazardous Materials Transportation Act (HMTA), 49 App. U.S.C. 1801-1819**

The HMTA authorizes the Secretary to inspect shipments of hazardous materials to ensure their safe movement in domestic and international transportation. Originally promulgated in 1975, this act was significantly changed by a 1990 amendment. This act and the regulations published in 49 CFR under its authority, apply to packaged cargoes (including tank trucks and rail cars) on waterfront facilities but not to the facilities themselves. This act also provides the statutory authority for the regulations in 46 CFR Part 148, which govern the transportation of bulk solid hazardous materials.

---

**6. E.O. 10173, as amended by E.O.s 10277, 10352, and 11249**

These E.O.s, issued pursuant to the Magnuson Act, 50 U.S.C. 191, prescribed certain port security regulations to be enforced by the Coast Guard. These Coast Guard regulations are in 33 CFR Part 6. The Commandant was further authorized to issue supplemental regulations to carry out this program. These orders provide authority to prevent both intentional and accidental loss or destruction of vessels or waterfront facilities. In the past, these orders have been used for the prevention of accidental losses (port safety); however, their primary intent is the prevention of intentional losses (port security).

---

**7. E.O. 12777**

E.O. 12777 delegated to the Secretary of the Department in which the Coast Guard operates, authority under the FWPCA for "the establishment of procedures, methods, and equipment and other requirements for equipment to prevent discharges of oil and hazardous substances from vessels and transportation related onshore and offshore facilities, and to contain such discharges." The regulations for marine oil and hazardous material transfer facilities and oil and hazardous material transfer operations (33 CFR Parts 154-156) are promulgated, in part, under this authority. The Administrator of the Environmental Protection Agency (EPA) is charged with determining those quantities of oil and hazardous substances that may be harmful and those that are not.

---

## SECTION B: DOMESTIC INSPECTION PROGRAMS

## CHAPTER 7: MARINE FACILITIES AND STRUCTURE

**8. Regulations**

- a. 33 CFR 6.12 authorizes COTPs to supervise and control the transportation, handling, loading, discharging, stowage, or storage of hazardous materials on board vessels under certain conditions.
  - (1) The Commandant is authorized to designate waterfront facilities for the handling, storage, and loading and discharging of explosives, flammable or combustible liquids in bulk, and other dangerous articles.
  - (2) The Commandant also has the authority to require permits for such handling, storage, loading, and unloading.
  - (3) Under 33 CFR 6.14, the Commandant is authorized to prescribe conditions and restrictions relating to the safety of waterfront facilities and vessels in port, as he deems necessary.
- b. 33 CFR Part 126. To implement 33 CFR 6.12 and 6.14, the Commandant promulgated 33 CFR Part 126 (Handling of Explosives or Other Dangerous Cargoes Within or Contiguous to Waterfront Facilities).
  - (1) These regulations designate types of waterfront facilities, permit requirements, and conditions that must be met and maintained by facilities involved in the handling, storage, loading, or discharging of explosives, blasting agents, oxidizers, radioactive materials, certain liquefied gases in bulk, or other dangerous articles.
  - (2) Although these regulations were initially issued under the Magnuson Act, they were reissued in 1977 under authority of the PWSA. The civil and criminal penalties of the PWSA now apply to these facility regulations.
- c. 33 CFR Part 127 applies to all waterfront facilities that transfer Liquefied Natural Gas (LNG), in bulk, to or from vessels.
  - (1) 33 CFR Part 127 was issued in 1988 under authority of the PWSA.
  - (2) 33 CFR Part 127 specifies standards for facility design, construction, equipment, operations, maintenance, training, firefighting, and security.
- d. 33 CFR Parts 154 and 156 apply to all onshore and offshore facilities capable of transferring oil or liquid hazardous material, in bulk, to or from any vessel with a capacity of 250 or more barrels (about 40 cubic meters) on the navigable waters or contiguous zone of the United States.

## SECTION B: DOMESTIC INSPECTION PROGRAMS

## CHAPTER 7: MARINE FACILITIES AND STRUCTURE

- e. Additional regulations. There are various references to waterfront facilities in Titles 46 and 49 of the CFR. The regulations under 49 CFR Parts 171-179 were promulgated under the authority of the HMTA.

---

**B. DEFINITIONS**

---

**1. Waterfront Facility**

The definition of what constitutes a waterfront facility varies depending upon the authorizing legislation and regulations. In general, a waterfront facility is a pier, wharf, dock or similar structure to which a vessel may be secured. Any equipment on the structure, any buildings on or contiguous to the structure, and any equipment or materials on the structure or in those buildings are also considered part of the facility. Structures, buildings, and equipment used in conjunction with pier equipment, but not within the areas described above, do not fall within the meaning of a waterfront facility. For example, storage tanks located beyond the immediate area of a pier facility, which are separate and distinct units connected to the pier facility only by pipeline, are not considered parts of the facility. Tanks located on a wharf are considered part of the facility, and jurisdiction applies to them. Specific limitations by authorizing legislation are as follows:

- a. Magnuson Act, 50 U.S.C. 191. For the purposes of the Magnuson Act, a waterfront facility includes any pier, wharf, dock or similar structure to which vessels may be secured. Areas of land or water in immediate proximity to such structures, equipment on the structure, and buildings on or contiguous to the structure are also considered part of the facility.
- b. PWSA, 33 U.S.C. 1221-1232(a). Although not specifically defined in either the PWSA, a waterfront facility includes any structure located in, on, or adjacent to the navigable waters of the United States and any land structure adjacent to the navigable waters of the United States. Areas of land or water in immediate proximity to these structures (piers and wharves), buildings on or contiguous to these structures, and any equipment or materials (including vehicles) on or in these buildings or structures, are also considered part of the facility.
- c. FWPCA, 33 U.S.C. 1321. For the purposes of the FWPCA, a waterfront facility includes any onshore facility" or "offshore facility" as defined in the act.
  - (1) An "onshore facility" is any facility (including, but not limited to, motor vehicles and rolling stock) of any kind located in, on, or under any land within the United States other than submerged land.

**SECTION B: DOMESTIC INSPECTION PROGRAMS****CHAPTER 7: MARINE FACILITIES AND STRUCTURE**

- (2) An "offshore facility" is any facility of any kind located in, on, or under any of the navigable waters of the United States and any facility of any kind which is subject to the jurisdiction of the United States and is located in, on, or under any other waters, other than a vessel or a public vessel.
- (3) This is a much broader definition of waterfront facility than provided by the above acts. Coast Guard jurisdiction is limited primarily by agreement with the EPA.

---

**2. Bulk**

Bulk is a material that is transported on board a vessel without mark or count and which is directly loaded into a hold or tank on a vessel without containers or wrappers.

---

**3. Contiguous**

As used in 33 CFR 126, contiguous means those buildings that connect with or adjoin piers, wharves, docks, and similar structures, including those buildings that connect directly with other buildings situated in whole or in part upon such structures are considered to be contiguous. A building that is located entirely off the structure of a pier or wharf and has no direct contact with it is not a contiguous building and is not part of the facility.

---

**4. Vessels and Non-Facility Equipment**

The definition of a waterfront facility under the Magnuson Act and the PWSA does not include vessels, railways, cranes, working areas, roadways, entrance and operating areas, stock and cargo piles, storage areas, container fields, parking lots, fueling areas, storage tanks, and handling areas, unless they are located upon the structure of the pier or wharf, or within a building upon or contiguous to the structure. Hence, a vessel temporarily moored to a waterfront facility does not become part of the facility.

---

**5. Designated Waterfront Facility**

A facility regulated under 33 CFR Part 126 that handles dangerous cargoes subject to 46 CFR Part 148 or 49 CFR Parts 171-179, is considered a designated waterfront facility. Under the provisions of 33 CFR 126.13, these cargoes can be handled, stored, stowed, loaded, discharged, or transported only at designated waterfront facilities that meet the requirements in 33 CFR 126.15. Bulk liquid waterfront facilities (other than certain liquefied gas facilities) are not covered under 33 CFR Part 126 and therefore are not designated waterfront facilities."

**SECTION B: DOMESTIC INSPECTION PROGRAMS****CHAPTER 7: MARINE FACILITIES AND STRUCTURE**

The definition of a designated waterfront facility under 33 CFR Part 126 is limited to those handling commodities subject to specific regulations. If a facility handles any materials that require it to be a designated waterfront facility under 33 CFR Part 126, it must store all hazardous materials in accordance with 33 CFR 126.15, even if the packages and/or quantities are exempted under 49 CFR Parts 171-179.

---

**6. Facility of Particular Hazard**

A facility of particular hazard is a designated waterfront facility (regulated under 33 CFR Part 126) that handles a cargo listed in 33 CFR 126.10. A facility of particular hazard must meet all the conditions in 33 CFR 126.15, plus the additional requirements in 33 CFR 126.16.

---

**C. TYPES OF WATERFRONT FACILITIES**

In general, waterfront facilities are regulated and inspected according to the types of hazardous products they transfer to or from vessels. Facilities that transfer products in more than one category will be inspected for compliance with each applicable set of regulations. In general, facilities are fixed structures. In some cases, tank trucks and rail cars can be considered mobile facilities (see 33 CFR 154.105). Under the PWSA, vehicles are not facilities; however, when a vehicle capable of transferring a liquefied gas drives onto a fixed structure, it becomes part of the equipment on the structure converting it into a liquefied gas transfer facility. Vessels inspected under the regulations in CFR Title 46 are never considered facilities; however, a permanently moored vessel that is not inspected under Title 46 may be considered part of a facility. Publicly owned or operated facilities are included in the definition of facility; however, facilities owned and operated by Federal agencies generally are not inspected by the COTP. The four general categories of waterfront facilities are: bulk liquefied gas, dry bulk, packaged, and bulk liquid. LNG facilities and LHG facilities are bulk liquefied gas facilities. Bulk liquid facilities, outer continental shelf facilities, and deepwater ports are covered elsewhere in this manual.

---

**1. Bulk Liquefied Natural Gas Waterfront Facilities**

- a. **Definition.** A bulk liquefied natural gas waterfront facility is any pier, wharf, dock or similar structure to which a vessel may be secured that is used, or is capable of being used, to transfer Liquefied Natural Gas (LNG) to or from a vessel, in bulk. The facility also includes areas of land, water, or land and water under and in immediate proximity to the structure, buildings on or contiguous to the structure, and equipment and materials on the structure or in the buildings. This term does not include facilities directly operated by the DOD.

## SECTION B: DOMESTIC INSPECTION PROGRAMS

## CHAPTER 7: MARINE FACILITIES AND STRUCTURE

- b. Jurisdiction. The bulk LNG facility requirements primarily apply to active facilities; however, some of the safety requirements may apply to facilities in caretaker status.
- (1) These rules are issued under the PWSA and therefore only apply to structures that are located in, on, or under the navigable waters of the United States (out to 5 kilometers).
  - (2) A tank truck or rail car that transfers liquefied gas from a structure converts that structure into a LNG facility. The owner of the structure or area of land and the operator of the tank truck or rail car are jointly responsible for ensuring that the requirements are met if a LNG transfer takes place.
  - (3) Jurisdiction on LNG facilities is generally limited by regulation to the marine transfer area. The marine transfer area on LNG facilities extends from the waterfront or manifold to the last valve prior to the receiving tank.
- c. Applicable regulations. Facilities handling LNG in bulk are regulated under 33 CFR Part 127. The MARPOL reception facility regulations in 33 CFR Part 158 may also apply to a LNG facility.

---

## 2. Bulk Liquefied Hazardous Gas Waterfront Facilities

- a. Definition. A bulk liquefied hazardous gas waterfront facility is any pier, wharf, dock or similar structure to which a vessel may be secured that is used, or is capable of being used, to transfer a Liquefied Hazardous Gas (LHG) to or from a vessel, in bulk. The facility also includes areas of land, water, or land and water under and in immediate proximity to the structure, buildings on or contiguous to the structure, and equipment and materials on the structure or in the buildings.
- (1) This term does not include facilities directly operated by the DOD.
  - (2) Liquefied hazardous gases are those products listed in 33 CFR 126.10(d).
- b. Jurisdiction. The bulk LHG facility requirements primarily apply to active facilities, however some of the safety requirements may apply to facilities in caretaker status.
- (1) These rules are issued under the PWSA and therefore only apply to structures that are located in, on, or under the navigable waters (out to 5 kilometers) of the United States. A tank truck or rail car that transfers LHG from a structure converts that structure into a LHG facility. The owner of the structure and the operator of the tank truck or rail car are jointly responsible for ensuring that the requirements are met if a LHG transfer takes place.

## SECTION B: DOMESTIC INSPECTION PROGRAMS

**CHAPTER 7: MARINE FACILITIES AND STRUCTURE**

- (2) Jurisdiction on LHG facilities is generally limited to the marine transfer area. The marine transfer area on LHG facilities extends from the waterfront or manifold to the first valve inland from the manifold, including the entire pier or wharf on which the transfer manifold is located.
- c. Applicable regulations. Facilities handling LHG in bulk are regulated under 33 CFR Part 126. The MARPOL reception facility regulations in 33 CFR Part 158 may also apply to a LHG facility.
- 

**3. Dry Bulk Waterfront Facilities**

- a. Definition. A dry bulk waterfront facility is any pier, wharf, dock or similar structure to which a vessel may be secured that is used, or is capable of being used, to transfer solid hazardous materials, to or from a vessel, in bulk.
- (1) The facility also includes areas of land, water, or land and water under and in immediate proximity to the structure, buildings on or contiguous to the structure, and equipment and materials on the structure or in the buildings.
- (2) This term does not include facilities directly operated by the DOD. Bulk solid hazardous materials are any materials, other than liquids or gases, listed in the 49 CFR 172.101 table and its appendix when shipped in bulk.
- (3) Bulk solid hazardous materials that may be transported on vessels without prior approval from the Commandant are listed in 46 CFR 148.01.
- b. Jurisdiction. These rules are issued under the PWSA and therefore only apply to structures that are located in, on, or under the navigable waters (out to 5 kilometers) of the United States.
- (1) When a truck or rail car transfers solid hazardous materials to or from a vessel, it and the structure on which it is located, are to be considered a waterfront facility covered under these rules.
- (2) Jurisdiction on dry bulk facilities includes the entire pier or wharf from which a transfer takes place, all buildings on or contiguous to such structures, and any equipment or materials on the structures or in the buildings.
- c. Applicable regulations. Facilities handling solid hazardous materials in bulk are regulated under 33 CFR 126. The MARPOL reception facility regulations in 33 CFR 158 may also apply to a dry bulk waterfront facility.
- 

**4. Packaged Hazardous Material Waterfront Facilities**

## SECTION B: DOMESTIC INSPECTION PROGRAMS

**CHAPTER 7: MARINE FACILITIES AND STRUCTURE**

- a. Definition. A packaged hazardous material waterfront facility is any pier, wharf, dock or similar structure to which a vessel may be secured that is used, or is capable of being used, to transfer packaged hazardous materials, to or from a vessel.
- (1) The facility also includes areas of land, water, or land and water under and in immediate proximity to the structure, buildings on or contiguous to the structure, and equipment and materials on the structure or in the buildings.
  - (2) This term does not include facilities directly operated by the DOD.
  - (3) Packaged hazardous materials are those materials covered under 49 CFR Parts 171-179 when carried in packages that meet the requirements of those parts, including materials shipped in transport vehicles (tank trucks, rail cars, etc.) and freight containers.
- b. Jurisdiction. These rules are issued under the PWSA and therefore only apply to structures that are located in, on, or under the navigable waters (out to 5 kilometers) of the United States.
- (1) When a truck or rail car transfers packaged hazardous materials to or from a vessel, it and the structure on which it is located, are a waterfront facility covered under these rules.
  - (2) Jurisdiction on packaged hazardous material facilities includes the entire pier or wharf from which a transfer takes place, all buildings on or contiguous to such structures, and any equipment or materials on the structures or in the buildings.
- c. These limits to jurisdiction over the waterfront facility do not apply to inspections of packaged hazardous materials consigned for shipment by water under the HMTA (49 U.S.C. 1801-1819), for which jurisdiction is not limited to waterfront facilities.
- d. Applicable regulations. Facilities handling packaged hazardous materials are regulated under 33 CFR Part 126. Packaged hazardous materials must meet the requirements in 49 CFR Parts 171-179. The MARPOL reception facility regulations in 33 CFR Part 158 may also apply to a packaged hazardous material waterfront facility.
-



**SECTION B: DOMESTIC INSPECTION PROGRAMS****CHAPTER 7: MARINE FACILITIES AND STRUCTURE****5. Outer Continental Shelf Facilities**

Inspections of these facilities will be conducted by the OCMI in accordance with 33 CFR Part 142 and 43 U.S.C. 1348(c).

---

**6. Deepwater Ports**

See MSM Volume VI, Ports and Waterways Activities, COMDTINST M16000.11 (Series), Chapter 2.

---

**7. Mixed Use Waterfront Facilities**

Some waterfront facilities fit into more than one facility type. For instance, a facility may handle both oil and liquefied gases in bulk.

In most cases, there is a distinct separation between the portions of the facility that handles these different categories of product and each portion can be treated as a separate facility. In some cases, the same area is used for different categories of product and that area must meet the requirements for more than one facility type.

If the requirements conflict, the COTP should apply the requirements that provide the highest level of safety.

---

---

**D. TYPES OF WATERFRONT FACILITY VISITS**

---

**1. Inspections**

An inspection is a formal visit to a waterfront facility to ensure its safe operation and to verify compliance with applicable safety, security, and pollution prevention regulations. The applicable regulations for each type of facility are listed in paragraph B of this chapter. The frequency of inspection will be established by the COTP. Before the inspection visit, inspecting personnel should review the facility file for previous instances of noncompliance, outstanding deficiencies, hot work permits, and any alternatives, exemptions, or waivers granted. The facility's latest operations manual should also be reviewed. Facility Inspectors should consider contacting cognizant state and local authorities (local fire department, state department of environmental protection, etc.) to see if they would like to conduct a joint inspection. Joint inspections promote interagency cooperation and reduce the inspection burden on the facility operator. After arriving at the facility, the inspection team should be

**SECTION B: DOMESTIC INSPECTION PROGRAMS****CHAPTER 7: MARINE FACILITIES AND STRUCTURE**

accompanied by a facility representative. The inspection team must record each discrepancy observed, including those corrected immediately. A report of the inspection, discrepancies found, and actions taken to correct those discrepancies must be entered into MISLE. The Waterfront Facility Inspection, Form CG-4200 may be used as a guide for inspectors; however, for most facility inspections, the Waterfront Facility Inspection, CG-4200 must be supplemented with a locally prepared checklist until an updated form is developed and distributed. A copy of the facility inspection report must be provided to the facility owner or operator.

---

**2. Surveys**

A facility survey is a detailed account of a facility's physical plant and equipment used to update Coast Guard files. Updated information must be entered into MISLE. Diagrams, photographs, manuals, permits, and similar information that cannot be stored in the MSIS facility file must be maintained by the COTP in a facility file that is readily available for use when responding to an emergency at the facility. Each waterfront facility must be surveyed every two years. The survey and an inspection should be combined into a single facility visit. Facility Inspectors should use the Port Security Checklist as a guide in collecting physical security information during the survey. Physical security surveys must also be conducted at passenger ship terminals and category I and II Key Asset Protection Program facilities which are not inspected waterfront facilities. For further information on facility surveys, see MSM Volume VI, Ports and Waterways Activities, COMDTINST M16000.11 (Series), Chapter ,1 and MSM Volume VII, Port Security, COMDTINST M16000.12 (Series), Chapter 2.

---

**3. Transfer Monitors**

When monitoring transfer operations between a vessel and facility, COTP personnel should monitor both facility and vessel operations during the transfer. The facility portion of the visit should be recorded in MISLE as a facility transfer monitor.

---

**4. Waste Reception Facility Inspections**

Each waterfront facility that is used by oceangoing tank vessels or other oceangoing vessels of more than 400 GT must provide MARPOL waste reception facilities (33 CFR Part 158). For coastal ports, most waterfront facilities must have waste reception facilities for oil and garbage even if no hazardous materials are transferred to or from the facility. Waste reception facility inspections may be conducted during the same visit when other inspections are conducted.

---

**SECTION B: DOMESTIC INSPECTION PROGRAMS****CHAPTER 7: MARINE FACILITIES AND STRUCTURE****5. Other Visits**

In addition to the above visits described in D.1 through D.4, it may be necessary to visit a waterfront facility for container inspections, investigations, inspection discrepancy follow-ups, operations manual reviews, document and certificate checks, firefighting equipment checks, pollution prevention/ compliance checks, hot work permit checks, and pollution response plan drills. If possible, these visits should be conducted in conjunction with vessel boardings at the facility. Every visit to a waterfront facility must be documented in MISLE.

---

**E. BULK LIQUEFIED NATURAL GAS WATERFRONT FACILITY INSPECTIONS**

---

**1. Applicable Regulations**

Liquefied Natural Gas (LNG) waterfront facilities are regulated separately from waterfront facilities that handle other bulk liquid hazardous materials. The regulations in 33 CFR Parts 154 and 156 do not apply to LNG facilities. Only LNG facilities are regulated under 33 CFR Part 127. There is no capacity threshold for these facilities and the requirements apply equally to fuel and cargo. The LNG facility requirements apply only if the product is transferred or stored as a liquid at the facility. There are no separate regulations for mobile LNG facilities; however, any pier, wharf, or area of land from which a mobile facility transfers LNG must meet the fixed facility requirements or obtain an alternative from the COTP.

---

**2. Letter of Intent and Manuals**

Each owner who intends to build a new waterfront facility to handle LNG in bulk, or plans new construction on an existing LNG facility, must notify the COTP of their intent. A letter of intent must be sent to the COTP at least 60 days before construction begins (33 CFR 127.007). If a facility becomes inactive, the owner or operator must submit a new letter of intent at least 60 days before it transfers LNG again. An LNG facility is considered active unless the facility owner or operator notifies the COTP that no LNG transfer operations are planned for the next 12 months. The COTP must review the letter of intent and construction plans. A letter of recommendation based on this review must be sent to the originator of the letter of intent and to the Federal and local authorities having jurisdiction. The COTP should seek public comments before making a recommendation and, for new LNG facilities, should consider public hearings or meetings. If any of the information in the letter of intent changes, the owner or operator must notify the COTP within 15 days. At least 30 days before transferring LNG, the facility owner or operator must submit two copies of the operations manual and two copies of the emergency manual to the COTP for review. If the operations manual meets 33 CFR 127.305 and the emergency manual meets 33 CFR 127.307, the COTP should mark the manuals with the words "Examined by the Coast Guard" and return one copy

## SECTION B: DOMESTIC INSPECTION PROGRAMS

**CHAPTER 7: MARINE FACILITIES AND STRUCTURE**

of each manual to the sender. One copy of each examined manual must be retained with the facility file at the COTP office. If a manual does not meet the regulatory requirements, the COTP should either require changes or approve an acceptable alternative. During inspections, ensure that the operations and emergency manuals have been examined by the COTP and maintained up to date. During monitors, ensure that the operations manual is readily accessible to the facility person in charge and that the transfer procedures in the operations manual are followed.

---

**3. Fire Safety**

The goal of fire safety practices on waterfront facilities is to prevent fires and explosions. It is also to ensure that the resources necessary to respond to a fire are available and in working order should a fire occur. On bulk LNG waterfront facilities, the threat of fire comes from both flammable products and their vapors. Vapor plumes from an LNG spill can travel a significant distance from the spilled liquid. The following fire safety requirements apply to bulk liquefied gas facilities:

- a. Smoking prohibitions. Under 33 CFR 127.615, smoking is prohibited in the marine transfer area of an LNG waterfront facility when there is LNG present. For practical purposes, this means no smoking on an active facility.
  - (1) During LNG facility inspections and monitors, inspecting personnel should ensure that anyone they see smoking is in an area where smoking is authorized.
  - (2) Also note anyone smoking on a vessel moored to the facility, since smoking is prohibited on the weather decks of tank vessels moored alongside a dock under 46 CFR 35.30-5(d).
- b. Hot work. Hot work is any welding, burning, cutting, or similar operation that generates heat or sparks that could ignite a flammable material. A permit from the COTP is required for such operations on LNG waterfront facilities under 33 CFR 127.617. See MSM Volume VI, Ports and Waterways Activities, COMDTINST M16000.11 (Series) for more information.
  - (1) General. The intent of this requirement is to prohibit indiscriminate hot work that could cause a fire or explosion by providing the COTP with authority to regulate such an operation.
    - (a) The prime consideration in evaluating hot work permit requests must be safety. If the degree of safety is questionable, a permit should not be issued. Liaison with local fire authorities is encouraged when evaluating unusual permit requests.

**SECTION B: DOMESTIC INSPECTION PROGRAMS****CHAPTER 7: MARINE FACILITIES AND STRUCTURE**

- (b) Permits may be issued for a single day, the duration of a single project, or for a longer period (up to one year) that will cover a number of projects, at the discretion of the COTP.
  - (c) In some cases, conditions may make some requirements for hot work permits unnecessary or not feasible. In these instances, the COTP may use the alternative authority provided by 33 CFR 127.017.
  - (d) In other cases, local or unusual conditions may make these requirements for hot work permits inadequate and additional conditions should be added to the permit. Any additional conditions specified by the COTP should be based upon sound safety standards such as NFPA or ANSI standards.
- (2) Hot work on a vessel moored to an LNG waterfront facility must be covered under a permit issued to the facility under 33 CFR 127.617.
- (3) Enforcement. The hot work permit requirements should be enforced to the maximum extent possible.
- (a) Where practical, hot work permit enforcement may be performed by local fire departments; however, COTP personnel must occasionally verify that the conditions on the permit are being followed, particularly on facilities that have a history of safety violations.
  - (b) If hot work is in progress during a facility inspection or monitor, the Marine or Facility Inspector should verify that the facility (or a vessel moored to the facility) has a permit for the hot work and that the conditions of the permit are being met.
- (4) References. NFPA has published the following standards for hot work:
- (a) Welding and Cutting," NFPA 51.
  - (b) "Welding Processes," NFPA 51B.
  - (c) "Control of Gas Hazards on Vessels to be Repaired," NFPA 306.
- c. Motor vehicles on the pier. Under 33 CFR 127.311, motor vehicles may only stop or park in designated parking spaces on an LNG facility. Motor vehicles must not be refueled on a LNG facility.
- d. Electrical installations. Under 33 CFR 127.105, electrical power systems (which include electrical wiring and equipment) on LNG facilities must conform to the National Electric Code (NFPA 70). LNG facilities must also have an emergency

## SECTION B: DOMESTIC INSPECTION PROGRAMS

**CHAPTER 7: MARINE FACILITIES AND STRUCTURE**

power source for the emergency shutdown system, communications equipment, firefighting equipment, and emergency lighting. During inspections and monitors, Facility Inspectors should look for the following electrical hazards:

- (1) Conditions that could cause arcing.
  - (2) Electric motors that are--
    - (a) Located too near combustible material;
    - (b) Located in damp places or subjected to corrosive vapors;
    - (c) Covered with rust, lint or dust;
    - (d) Burning out because of overloading or low voltage at motor terminals;
    - (e) Protected by improper overcurrent protection; or,
    - (f) Producing excessive heat;
  - (3) Bare wires;
  - (4) Loose or frayed connections;
  - (5) Overloaded outlets;
  - (6) Corroded terminals;
  - (7) Lack of high voltage signs near transformers and switch boxes; and,
  - (8) Defective insulation.
- e. Open fires. Open fires in lamps, barrels, drums, or similar apparatus are prohibited. These requirements should be strictly enforced within the marine transfer area when a pipe or tank contains LNG or LNG vapors (see 33 CFR 127.615).
- f. Maintenance stores and supplies. Under 33 CFR 127.313, materials that may be stored in bulk on LNG facilities are limited to LNG, Liquefied Petroleum Gas (LPG), vessel fuel, and oily waste from vessels.
- (1) Other flammable products, such as solvents, lubricants, paints, and fuels, may only be stored on LNG facilities in amounts that could reasonably be used in one day. These flammable products must be stored in accordance with chapter 4 of NFPA 30.

**SECTION B: DOMESTIC INSPECTION PROGRAMS****CHAPTER 7: MARINE FACILITIES AND STRUCTURE**

- (2) During inspections, inspecting personnel should look for containers of flammable liquids or other hazardous materials left on the pier or wharf. Inspecting personnel should make sure containers in storage compartments are not leaking or left open so that vapors accumulate in the storage compartment.
- g. Fire extinguishing equipment. Fire extinguishing and protection equipment is essential to the safe operation of any waterfront facility.
- (1) See 33 CFR Parts 127.601 through 127.611 for the requirements for firefighting equipment on LNG facilities. These regulations describe the required fire main systems, dry chemical systems, and portable fire extinguishers.
- (2) Under 33 CFR 127.601(b), fire appliances such as hydrants, standpipes, fire extinguishers, hose stations, and fire monitors must be red or some other conspicuous color and must be in locations that are readily accessible.
- (3) Once installed, fire extinguishing and protection equipment must be maintained in good condition at all times. See 33 CFR 127.405 for information about repairs.
- (4) During inspections, inspection personnel should look for improperly marked fire appliances, material blocking access to fire appliances, and appliances that are not functional (excessive corrosion, missing fire hoses, etc.). They should also make sure that the international shore connection is available. A waterfront LNG facility must have at least one international shore connection.
- h. Warning signs. Warning signs must be displayed on each LNG waterfront facility at the point of transfer. These signs must be visible from both the shore and the water and must conform to the requirements in 33 CFR 127.113.
- (1) Vessels carrying LNG in bulk are also required to display warning signs that meet the requirements in 46 CFR 154.1830.
- (2) The intent of this requirement is to warn persons and vessels approaching the facility of the hazardous nature of the operation.

---

**4. Transfer Operations**

- a. PIC. At all times during the transfer of a liquefied gas to or from a vessel, the transfer system in use must be under the supervision of a qualified PIC. See 33 CFR 127.319(a) for the relevant regulation.

**SECTION B: DOMESTIC INSPECTION PROGRAMS****CHAPTER 7: MARINE FACILITIES AND STRUCTURE**

- (1) On a LNG facility, a PIC must be trained and certified in accordance with 33 CFR 127.301 to be qualified. The training must include at least 48 hours of LNG transfer experience.
  - (2) Each PIC must know the hazards of the cargo being transferred, the regulations that apply to the operation, and the facility's operating and emergency procedures.
  - (3) Written certification of the PIC's training must be maintained at the facility.
  - (4) The person assigned as PIC at the facility must not be assigned as PIC of the vessel's transfer operation or to any other duties that may prevent him or her from carrying out his or her duties as PIC on the facility.
- b. Communications. Communication between the PIC on the facility and the PIC aboard the vessel are vital to the safe transfer of LNG in bulk.
- (1) The shoreside PIC must maintain communications in accordance with the requirements in 33 CFR 127.111 and 33 CFR 127.319(b)(1).
  - (2) During monitors, the PIC must have an effective means of communication. If there is some doubt as to the effectiveness of communications, a communications check is required.
- c. Transfer connections. Connections between transfer hoses or loading arms and fixed piping must be secured with sufficient bolts and suitable gasket material to prevent leakage. The connections must allow for vessel movement within the limits of its moorings without placing strain on the transfer piping or loading arm.
- (1) See 33 CFR 127.315 for specific requirements.
  - (2) During monitors, check transfer connections for the number of bolts used. Carefully check questionable connections for leaks. A portable combustible gas indicator can be used to check for natural gas leaks.
- d. Preliminary transfer inspection. Before commencing a cargo transfer, the facility PIC must ensure that the conditions for transfer have been met. This includes verifying that the hot work, warning sign, and transfer connection requirements have been met, as well as verifying that the PIC aboard the vessel is ready to begin the transfer.
- (1) On LNG facilities, the items listed in 33 CFR 127.315 must be checked and a Declaration of Inspection (DOI) completed jointly with the vessel PIC, as required under 33 CFR 127.317.
  - (2) During monitors, ensure that the DOI is properly completed and signed.



**CHAPTER 7: MARINE FACILITIES AND STRUCTURE****5. Transfer System Testing Requirements**

- a. Transfer hoses and piping. On LNG facilities, each transfer hose, loading arm, and cargo transfer pipe must be hydrostatically tested at least once each year and each time major alterations are made to the system (see 33 CFR 127.407(a)).
- (1) Each cargo transfer hose and pipe must be subjected to at least 1.1 times its maximum allowable working pressure for at least 30 minutes during the test (see 33 CFR 127.407(b)).
  - (2) Bulk LNG hoses and piping must not be tested with LNG, but may be tested with non-hazardous liquids other than water.
  - (3) Where hydrostatic testing is impractical, the COTP may authorize pneumatic testing of cargo hoses and piping with the condition that the precautions in 46 CFR 56.97-35 are followed during testing.
  - (4) Before granting alternatives or waivers for hydrostatic tests, the COTP must consider the following factors:
    - (a) Length of transfer system under evaluation.
    - (b) Access to transfer system (buried, elevated, insulated, etc.).
    - (c) The presence of any relief valves in the system and their routine maintenance schedule.
    - (d) The age of the system.
    - (e) The history of the system (e.g., what commodities the system has been used for, major alterations made).
    - (f) The date of the last hydrostatic test.
- b. Other transfer system equipment. Other transfer system equipment must be periodically checked or tested to ensure proper operation and maintenance.
- (1) The set pressure on each relief valve must be tested or the relief valve must be visually inspected during the annual piping test (see 33 CFR 127.403 and 127.407).
  - (2) The date and results of these tests and inspections must be recorded and maintained at the facility.

## SECTION B: DOMESTIC INSPECTION PROGRAMS

## CHAPTER 7: MARINE FACILITIES AND STRUCTURE

- (3) During annual inspections, check facility records to verify that these tests and inspections have been recorded.

---

## 6. Occupational Safety

The Coast Guard and the Occupational Safety and Health Administration (OSHA) share responsibility for the safety of workers on waterfront facilities handling hazardous materials. The Coast Guard's primary responsibility in this area is the safe handling of hazardous materials. As liquid bulk facilities, LNG facilities are not covered by the OSHA marine terminal regulations in 29 CFR 1917. Instead, these facilities are covered by the general OSHA workplace regulations in 29 CFR Part 1910.

- a. Lighting. To prevent accidents, waterfront facilities must be adequately illuminated when handling hazardous materials during periods of darkness.
- (1) Adequate lighting is required under 33 CFR 127.109.
  - (2) The light level must be at least 55 lux at each transfer point and at least 11 lux in other parts of the transfer area. Measurements of light intensity should, if possible, be made with a light meter.
  - (3) Lights should be installed over aisles and in other locations where they will not be damaged by cargo handling equipment or vehicles.
  - (4) Light fixtures should be protected by wire guards unless mounted out of the normal reach of equipment and personnel.
  - (5) Open flame lights and lanterns using kerosene or gasoline are prohibited.
  - (6) When monitoring a transfer after dark, ensure that the work area lighting meets the regulatory requirements.
- b. Cargo information. Information about the cargo being transferred or stored at a facility is necessary to contain and clean up cargo spills, safely extinguish cargo fires, and treat persons exposed to the cargo. Under 33 CFR 127.307 each LNG facility must have an emergency manual that contains information on emergency response, firefighting, and first aid procedures for LNG.
- c. Warning alarms. Warning alarms are intended to alert approaching vessels and the local community in the event of an LNG release.
- (1) Each LNG facility must have both a siren and a rotating (or flashing) amber light that meet the specifications in 33 CFR 127.207.

**SECTION B: DOMESTIC INSPECTION PROGRAMS****CHAPTER 7: MARINE FACILITIES AND STRUCTURE**

- (2) The adequacy of these warning alarms should be verified during the annual facility inspection.
- (3) On LNG facilities, the light intensity and sound decibels should be verified from placards affixed to the equipment or equipment manuals. If appropriate placards and manuals are not available, compliance should be verified in the same manner as for LHG facilities.

---

**7. Security**

- a. Guards. The security requirements in 33 CFR Part 105 and Part 127.701-127.711 do not specifically require guards; however, they do require access control and security patrols, which usually require guards.
  - (1) Trained guards should be provided in sufficient numbers to provide surveillance of the waterfront facility to deter unlawful entry, deter vandalism, detect fire hazards, detect discharges of hazardous materials, and check the readiness of protective equipment.
  - (2) Guards should be thoroughly instructed in the operation of fire alarm boxes, fire hoses, portable fire extinguishers, and similar fire equipment. They should know the location of telephones and emergency equipment, emergency fire protection measures, and emergency notification procedures.
  - (3) The NFPA has developed two standards applicable to guards that may be used in determining the adequacy of guards: Guard Service - NFPA 601, and Guard Operations - NFPA 601A.
  - (4) When determining whether the number of guards provided is adequate for a facility, the COTP should consider the security barriers and detection devices in place.
- b. Guard requirement alternatives. Under 33 CFR 127.017, the COTP may approve alternatives to guards on LNG facilities where the stationing of guards is impractical.
  - (1) Alternatives for guard requirements should only be considered for small transfer facilities that are not manned between transfer operations and do not store bulk liquid hazardous materials on site, which is generally not applicable to LNG facilities. Such a facility may be secured by fencing and monitored by intrusion detection devices, cameras, or random patrols rather than permanent guards.

**SECTION B: DOMESTIC INSPECTION PROGRAMS****CHAPTER 7: MARINE FACILITIES AND STRUCTURE**

- (2) When reviewing requests for alternatives to the guard requirements, the COTP must consider the security barriers and detection devices in place, the likelihood of intrusion, the proximity of population centers, and the danger presented by any tanks or piping containing hazardous materials.
- c. Security barriers. Fences, walls, and similar barriers act as a deterrent to unauthorized entry onto waterfront facilities handling or storing hazardous materials.
- (1) Buildings, water bodies, ravines, and similar barriers may also be used to deter entry but may need to be augmented by safeguards such as fences, walls, patrols, surveillance cameras, or intrusion detection devices.
- (2) Under 33 CFR 127.709, impounding spaces, control stations, and electrical power sources on LNG facilities must be within a fence or wall.
- (3) Security barriers should be considered when determining the appropriate number of guards on the facility.

**8. Records**

According to 33 CFR 126.15(a)(8) and 127.409, LNG facilities must keep and make available to the COTP certain records of alternatives approved by the COTP, equipment tests, and DOIs.

The MISLE facility file is the official Coast Guard record for facility information.

A paper file must be maintained by the COTP for each facility in the zone for any facility information that cannot be maintained in MISLE including a copy of the operations manual, a copy of the emergency manual, a copy of the worksheet or checklist used during inspections, facility plans or diagrams, and similar information.

**F. BULK LIQUEFIED HAZARDOUS GAS WATERFRONT FACILITY INSPECTIONS****1. Applicable Regulations**

LHG waterfront facilities are regulated separately from waterfront facilities handling LNG and other bulk liquid hazardous materials. LHGs are listed in 33 CFR table 127.005. LHG facilities must comply with the requirements of 33 CFR Part 126. There is no capacity threshold for LHG facility requirements. These requirements apply only if the product is transferred or stored as a liquid cargo at the facility. There are no separate regulations for

**SECTION B: DOMESTIC INSPECTION PROGRAMS****CHAPTER 7: MARINE FACILITIES AND STRUCTURE**

mobile LHG facilities; however, any pier, wharf, or area of land from which a mobile facility transfers LHG must meet the fixed facility requirements or obtain a waiver from the COTP. The regulations in 33 CFR Parts 154 and 156 do not apply to LHG facilities.

---

**2. General Permit**

LHG facilities are not required to have an intent or operations manual. Instead, each facility is automatically issued a general permit to handle, store, stow, load, discharge, or transport LHG under 33 CFR 126.27. If an individual decides to operate an LHG facility, they are not required to notify the Coast Guard. Each LHG facility must meet certain conditions in 33 CFR 126.15 and 126.27. If a facility fails to meet those conditions, the COTP may terminate or suspend the general permit to handle LHG. (See MSM Volume VI, Ports and Waterways Activities, COMDTINST M16000.11 (Series), Section 1.H.1.) Each COTP must be alert for changes in LHG operations within their COTP zone.

---

**3. Fire Safety**

The purpose of fire safety on waterfront facilities is to prevent fires and explosions and ensure that the resources necessary to respond to a fire are available and in working order should a fire occur. On bulk LHG waterfront facilities, the threat of fire comes from both flammable products and their vapors. Vapor plumes from a flammable liquefied gas spill can travel a significant distance from the spilled liquid. The following fire safety requirements apply to bulk liquefied gas facilities:

- a. Smoking prohibitions. (33 CFR 127.1113) prohibits smoking on LHG waterfront facilities except where designated by the owner or operator of the facility.
  - (1) Smoking may only be permitted on LHG facilities in accordance with local ordinances and regulations.
  - (2) Where there are no local ordinances, the COTP should ensure that all locations classified as hazardous in NFPA 70 (generally within 15 meters of where flammable hazardous materials are stored) are posted as no smoking areas.
  - (3) Smoking restrictions generally do not apply if the LHG handled is not flammable. Questionable cases should be discussed with local authorities.
  - (4) Signs must be conspicuously posted indicating those areas where smoking is authorized and those areas where smoking is prohibited.

## SECTION B: DOMESTIC INSPECTION PROGRAMS

**CHAPTER 7: MARINE FACILITIES AND STRUCTURE**

- (5) It is not enough for the facility owner or operator to post signs, the restrictions must also be enforced.
- (6) Personnel should look for "no smoking" signs near piping and tanks for flammable products during LHG facility inspections and monitors.
  - (a) Personnel who see someone smoking should make sure that person is in an area where smoking is authorized.
  - (b) Personnel should also note anyone smoking on a vessel moored to the facility, since smoking is prohibited on the weather decks of tank vessels moored alongside a dock under 46 CFR 35.30-5(c).
- b. Hot work. Hot work is any welding, burning, cutting, or similar operation that generates heat or sparks that could ignite a flammable material. Under 33 CFR 126.15(c), prior approval of the COTP is required for such operations on LHG waterfront facilities. A hot work permit is the preferred means for giving COTP approval for hot work operations. (See MSM Volume VI, Ports and Waterways Activities, COMDTINST M16000.11 (Series), Section 1.H.5 for more information.)
  - (1) General. The intent of this requirement is to prohibit indiscriminate hot work that could cause a fire or explosion by providing the COTP with authority to regulate such an operation.
  - (2) The prime consideration in evaluating hot work permit requests must be safety. If the degree of safety is questionable, a permit should not be issued. Liaison with local fire authorities is encouraged when evaluating unusual permit requests.
  - (3) Permits may be issued for a single day, the duration of a single project, or for a longer period (up to one year) that will cover a number of projects, at the discretion of the COTP.
  - (4) In some cases, local or unusual conditions may make some of these requirements unnecessary or not feasible. In these instances, the COTP may use the waiver authority provided by 33 CFR 126.11.
  - (5) In other cases, local or unusual conditions may make these requirements inadequate and additional conditions should be added to the permit. Any additional conditions specified by the COTP should be based upon sound safety standards such as NFPA or ANSI standards.
  - (6) Hot work on a vessel moored to an LHG facility must be covered under a permit issued to the facility under 33 CFR 126.15(c).

## SECTION B: DOMESTIC INSPECTION PROGRAMS

**CHAPTER 7: MARINE FACILITIES AND STRUCTURE**

- c. Enforcement. The hot work permit requirements should be enforced to the maximum extent possible.
- (1) Where practical, hot work permit enforcement may be performed by local fire departments; however, COTP personnel must occasionally verify that the conditions on the permit are being followed, particularly on facilities that have a history of safety violations.
  - (2) If hot work is in progress during a facility inspection or monitor, verify that the facility (or a vessel moored to the facility) has a permit for the hot work and that the conditions of the permit are being met.
- d. References. NFPA has published the following standards for hot work:
- (1) "Welding and Cutting," NFPA 51.
  - (2) "Welding Processes," NFPA 51B.
  - (3) "Control of Gas Hazards on Vessels to be Repaired," NFPA 306.
- e. Motor vehicles on the pier. Under 33 CFR 127.1311, unattended motor vehicles may only remain on a LHG facility when parked in parking spaces designated by the facility owner or operator in conformance with local ordinances and regulations.
- (1) If a vehicle is waiting to load or discharge cargo, equipment, supplies, or passengers it must be attended by a driver. The COTP may waive this requirement if the vehicle does not block the flow of traffic and the vehicle engine is stopped.
  - (2) The number of vehicles permitted on the pier or wharf at one time should be limited to permit free traffic flow. Filling vehicle fuel tanks while on the LHG facility is prohibited under 33 CFR 127.1311(b).
- d. Equipment on the pier driven by internal combustion engines. 33 CFR 126.15(e) provides additional safety requirements for equipment that is driven by an internal combustion engine and is regularly used on an LHG waterfront facility.
- (1) Such equipment includes forklifts, generators, and pumps, as well as motor vehicles.
  - (2) The equipment must be kept free from excessive oil, grease, and lint so as not to constitute a fire hazard.

## SECTION B: DOMESTIC INSPECTION PROGRAMS

## CHAPTER 7: MARINE FACILITIES AND STRUCTURE

- (3) Each piece of equipment must carry an approved fire extinguisher unless the equipment is operating in an area where extinguishers are available on the facility, and the COTP has approved the arrangement.
  - (4) Equipment that is not attached to the pier or wharf should not be stored or fueled on the pier or wharf. Such equipment should be stored or fueled in designated areas away from the pier or wharf.
- e. Rubbish and waste materials. The requirements in 33 CFR 126.15(f) address the fire hazards created by poor housekeeping on LHG facilities. Fire safety inspections should include out-of-the-way places as well as obvious areas. Both the insides and outsides of sheds and other buildings should be examined. Hazards and potential hazards that could cause a fire to start or hinder firefighters should be noted and corrected. Inspectors should be alert to--
- (1) Piles of dunnage or scrap;
  - (2) Rubbish or waste materials on piers or wharves;
  - (3) Sloppy carpenter and paint shops, etc.;
  - (4) Railroad cars laden with waste materials;
  - (5) Inadequate or unsuitable waste cans (rubbish should be kept in metal containers with covers, and removed or emptied at frequent intervals to prevent dangerous accumulations); and,
  - (6) Hazardous accumulations of dust on trusses, girders, or other structural members.
- f. Electrical installations. Under 33 CFR 126.15(h), installations of electrical wiring and equipment on LHG facilities made after 28 August 1951 must be in accordance with accepted safe practices.
- (1) Conformance to the National Electric Code and to local ordinances and regulations is considered to meet the safe practices requirement.
  - (2) Electrical equipment, fittings, and other devices must be approved for use by the Underwriters Laboratories, Inc. (UL), the Associated Factory Mutual Laboratories (FM), or the Canadian Standards Association (CSA). National Bureau of Standards (NBS) approval is also acceptable under 33 CFR 126.15(h), however NBS no longer issues such approvals.
  - (2) All electrical wiring and equipment, including that installed prior to 28 August 1951 must be maintained in a safe condition without defects or modifications that



## SECTION B: DOMESTIC INSPECTION PROGRAMS

**CHAPTER 7: MARINE FACILITIES AND STRUCTURE**

could cause a fire or personal injury. Defective or dangerous wiring, equipment, and devices must be replaced, removed or permanently disconnected.

- (4) During inspections and monitors, personnel should look for the following electrical hazards:
- (a) Conditions which could cause arcing.
  - (b) Electric motors that are:
    - [1] Located too near combustible material;
    - [2] Located in damp place or subjected to corrosive vapors;
    - [3] Covered with rust, lint or dust;
    - [4] Burning out because of overloading or low voltage at motor terminals;
    - [5] Protected by improper overcurrent protection; or,
    - [6] Producing excessive heat.
  - (c) Bare wires.
  - (d) Loose or frayed connections.
  - (e) Overloaded outlets.
  - (f) Corroded terminals.
  - (g) Lack of high voltage signs near transformers and switch boxes.
  - (h) Defective insulation.
- g. Heating methods. 33 CFR 126.15(i) requires heating equipment on LHG facilities to be safely installed and maintained in good operating condition.
- (1) The recommended guide for safe installation of heating equipment is the National Board of Fire Underwriters Building Code.
  - (2) For portable electric heating equipment, approval by CSA, FM, or UL should be used as a guide for safe design and NFPA 70 should be used as a guide for safe installation.

**SECTION B: DOMESTIC INSPECTION PROGRAMS****CHAPTER 7: MARINE FACILITIES AND STRUCTURE**

- (3) Adequate clearances must be provided for heating equipment to prevent undue heating of nearby combustible materials.
  - (4) In addition, 33 CFR 126.15(i) requires that spark arresters be provided if the heater uses solid fuel.
  - (5) Open fires in lamps, barrels, drums, or similar apparatus are prohibited. These requirements should be strictly enforced, particularly in areas within 30 meters of a pipe or tank containing flammable products.
  - (6) During inspections, personnel should look for improper heaters in sheds or shelters on the facility.
- h. Maintenance stores and supplies. Under 33 CFR 126.15(g) supplies that are regulated as hazardous materials under 49 CFR Parts 171 through 179 must be kept on LHG facilities only in amounts necessary to meet normal operating requirements. These materials must be stored in appropriate storage compartments (paint lockers, etc.). During inspections, personnel should look for containers of flammable liquids or other hazardous materials left on the pier or wharf and make sure containers in storage compartments are not leaking or left open so that vapors accumulate in the storage compartment.
- i. Fire extinguishing equipment. Fire extinguishing and protection equipment is essential to the safe operation of any waterfront facility. The quantity, type, and location of equipment required for LHG facilities varies depending on the products handled and the hazards they present.
- (1) Under 33 CFR 126.15(j), fire extinguishing equipment must be available on each LHG facility in adequate quantities, locations, and types. The COTP should work with the local fire authority in determining the adequacy of fire equipment. NFPA 307 and NFPA 10 may be used as guides when determining adequacy of that equipment.
  - (2) Once installed, fire extinguishing and protection equipment must be maintained in good condition at all times.
  - (3) Under 33 CFR 126.15(k), fire appliances such as hydrants, standpipes, fire extinguishers, hose stations, and fire alarm boxes must be conspicuously marked and readily accessible. The color used in marking depends upon local regulations; however, fire appliances are generally marked in red and their purpose or number shown in white lettering. The markings must be placed high enough that they will not be hidden by cargo, stanchions, columns, risers, or other obstructions.
  - (4) All locations of fire appliances should be numbered and indicated on the facility's floor plan.

**SECTION B: DOMESTIC INSPECTION PROGRAMS****CHAPTER 7: MARINE FACILITIES AND STRUCTURE**

- (5) If the fire equipment on an LHG facility is inadequate, the COTP must notify the facility operator of the problem in writing and provide the operator an opportunity to correct the situation.
  - (6) During inspections, personnel should look for improperly marked fire appliances, material blocking access to fire appliances, and appliances that are not functional (excessive corrosion, missing fire hoses, etc.).
- j. Warning signs. Warning signs must be displayed on each LHG waterfront facility at the point of transfer. The goal of this requirement is to warn vessels approaching the facility of the hazardous nature of the operation.
- (1) Warning signs must face parallel to and perpendicular to the shoreline. They must be visible from vessels on the waterway at all times during the transfer.
  - (2) On LHG facilities, these signs must conform to the requirements in either 46 CFR 151.45-2(e)(1) or 46 CFR 153.955.
  - (3) Vessels carrying LHG in bulk are also required to display warning signs that meet the requirements in 46 CFR 35.30-1, 151.45-2, or 153.955, as applicable.

---

**4. Transfer Operations**

- a. PIC. When transferring LHG to or from a vessel, the transfer system in use must be under the continuous control and surveillance of a qualified PIC.
  - (1) To be qualified, the PIC must be trained, and the training documented, in accordance with 33 CFR 126.15(o)(1). Evidence of training for PICs on LHG facilities must be provided to the COTP prior to the transfer.
  - (2) The person assigned as PIC on the facility must not be assigned as PIC of the vessel's transfer operation or to any other duties that may prevent him or her from carrying out his or her duties as PIC on the facility.
  - (3) The COTP may authorize a single person to be the PIC on both the facility and the vessel if the proposed operations provide adequately for the safety of the vessel and the facility. However, such authorizations should not be routinely authorized for LHG transfers due to the complexity of transfer operations and the hazardous nature of the cargo.
- b. Communications. Communications between the PIC on the facility and the PIC aboard the vessel are vital to the safe transfer of bulk liquefied gases.

**SECTION B: DOMESTIC INSPECTION PROGRAMS****CHAPTER 7: MARINE FACILITIES AND STRUCTURE**

- (1) The shoreside PIC must maintain communications in accordance with 33 CFR 126.15(o)(3).
  - (2) During monitors, make sure that the PIC has an appropriate means of communication. If there is some doubt as to the effectiveness of communications, a communications check is required.
- c. Transfer connections. Connections between transfer hoses or loading arms and fixed piping must be secured with sufficient bolts and suitable gasket material to prevent leakage. The connections must allow for vessel movement within the limits of its moorings without placing strain on the transfer piping or loading arm.
- (1) Specific requirements are contained in 33 CFR 126.15(o)(2).
  - (2) During monitors, check transfer connections for the number of bolts used. Carefully check questionable connections for leaks. A portable combustible gas indicator can be used to check for flammable gas leaks.
- d. Preliminary transfer inspection. Before commencing a cargo transfer, the facility PIC must ensure that the conditions for transfer have been met. This includes verifying that the hot work, warning sign, and transfer connection requirements have been met, as well as verifying that the PIC aboard the vessel is ready to begin the transfer.
- (1) When applicable, a copy of the vessel's DOI required under 46 CFR 35.35-30 should be obtained and, to the extent possible, the vessel's condition verified to be as stated on the DOI.
  - (2) During monitors, ensure that the vessel's DOI is properly completed and signed.

---

**5. Transfer System Testing Requirements**

- a. Transfer hoses and piping. Each transfer hose, loading arm, and cargo transfer pipe must be hydrostatically tested at least once each year.
  - (1) On LHG facilities, each cargo transfer hose and pipe must be subjected to at least 1.5 times its maximum allowable working pressure during the test (see 33 CFR 126.15(o)(7)(v)).
  - (2) LHG hoses and piping should not be tested with hazardous products, but may be tested with non-hazardous liquids other than water.

**SECTION B: DOMESTIC INSPECTION PROGRAMS****CHAPTER 7: MARINE FACILITIES AND STRUCTURE**

- (3) Where hydrostatic testing is impractical, the COTP may authorize pneumatic testing of cargo hoses and piping with the condition that the precautions in 46 CFR 56.97-35 are followed during testing.
- (4) Before granting alternatives or waivers for hydrostatic tests, the COTP must consider the following factors:
  - (a) The length of the transfer system under evaluation.
  - (b) The access to the transfer system (if it is buried, elevated, insulated, etc.).
  - (c) The presence of any relief valves in the transfer system and their routine maintenance schedules.
  - (d) The age of the transfer system.
  - (e) The history of the transfer system (e.g., what commodities the system has been used for, major alterations made).
  - (f) The date of the last hydrostatic test.
- b. Other transfer system equipment. Other transfer system equipment must be periodically checked or tested to ensure proper operation and maintenance.
  - (1) On LHG waterfront facilities, each cargo pump system and relief valve must be tested at least once each year.
  - (2) Each cargo pump pressure gauge must be calibrated at least once each year (see 33 CFR 126.15(o)(7)).
  - (3) The date and results of these tests and inspections must be recorded and maintained at the facility. During annual inspections, check facility records to verify that these tests and inspections have been recorded.

---

**6. Occupational Safety**

The Coast Guard and OSHA share responsibility for the safety of workers on waterfront facilities handling hazardous materials. The Coast Guard's primary responsibility in this area is the safe handling of hazardous materials. As liquid bulk facilities, LHG facilities are not covered by the OSHA marine terminal regulations in 29 CFR Part 1917. Instead, these facilities are covered by the general OSHA workplace regulations in 29 CFR Part 1910.

## SECTION B: DOMESTIC INSPECTION PROGRAMS

**CHAPTER 7: MARINE FACILITIES AND STRUCTURE**

- a. Lighting. To prevent accidents, waterfront facilities must be adequately illuminated when handling hazardous materials during periods of darkness.
- (1) No lighting intensity is specified for LHG facilities; however, if an LHG facility's lighting does not approximate the LNG facility requirements of at least 55 lux at each transfer point and at least 11 lux in other parts of the transfer area, the lighting should be considered inadequate.
  - (2) If the lighting on an LHG facility is inadequate, the COTP must notify the facility operator of the problem in writing and provide the operator an opportunity to correct the situation (33 CFR 126.15(n)).
  - (3) Measurements of light intensity should, if possible, be made with a light meter.
  - (4) Lights should be installed over aisles and in other locations where they will not be damaged by cargo handling equipment or vehicles.
  - (5) Light fixtures should be protected by wire guards unless mounted out of the normal reach of equipment and personnel (33 CFR 126.15(n)).
  - (6) Open flame lights and lanterns using kerosene or gasoline are prohibited (33 CFR 126.15(l)).
  - (7) Temporary lighting, when required, must be obtained from battery powered flashlights or protected electric lamps that are energized from portable electric generators, located outside off the pier.
  - (8) When monitoring a transfer after dark, ensure that the work area lighting meets the regulatory requirements.
- b. Cargo information. Under 33 CFR 126.15(o)(2)(vii), the LHG facility PIC must possess a cargo information card for each LHG handled. Information on the cargo being transferred or stored at a facility is necessary to contain and clean up cargo spills, safely extinguish cargo fires, and treat persons exposed to the cargo. The cargo information card must include--
- (1) The name of the cargo;
  - (2) The cargo's appearance, color, and odor;
  - (3) The hazards involved in handling the cargo;
  - (4) Any special handling procedures for the cargo;

**SECTION B: DOMESTIC INSPECTION PROGRAMS****CHAPTER 7: MARINE FACILITIES AND STRUCTURE**

- (5) Procedures to follow if the cargo spills or leaks;
  - (6) Procedures for treating a person exposed to the cargo; and,
  - (7) Firefighting procedures and extinguishing agents effective for combating a cargo fire.
- c. Warning alarms. Warning alarms are intended to alert approaching vessels and the local community in the event of a liquefied gas release.
- (1) Each LHG facility is considered a facility of particular hazard and must meet the requirement for a warning alarm in 33 CFR 126.16(b).
  - (2) The warning alarm may be either a siren or a rotating, flashing light. The color of the rotating flashing light is not prescribed, however, amber is recommended because it is considered most effective in alerting personnel to a hazard.
  - (3) The adequacy of warning alarms should be verified during the annual facility inspection. The alarm should be activated while a member of the inspection team, located 1,600 meters away, determines if it can be seen or heard. Inspectors should be particularly alert to obstructions that could prevent a warning light from being seen from the waterway.

---

**7. Security**

- a. Guards. Trained guards are required in sufficient numbers to provide surveillance of the waterfront facility to deter unlawful entry, deter vandalism, detect fire hazards, detect discharges of hazardous materials, and check the readiness of protective equipment.
- (1) Guards should be thoroughly instructed in the operation of fire alarm boxes, fire hoses, portable fire extinguishers, and similar fire equipment. They should know the location of telephones and emergency equipment, emergency fire protection measures, and emergency notification procedures.
  - (2) The NFPA has developed two standards applicable to guards that may be used in determining the adequacy of guards required under 33 CFR 126.15(a): Guard Service - NFPA 601, and Guard Operations - NFPA 601A.
  - (3) When determining whether the number of guards provided is adequate for a facility, the COTP should consider the security barriers and detection devices in place.

**SECTION B: DOMESTIC INSPECTION PROGRAMS****CHAPTER 7: MARINE FACILITIES AND STRUCTURE**

- (4) If the guards for an LHG facility are found to be inadequate, the COTP must notify the facility operator of the problem in writing and provide the operator an opportunity to correct the situation.
- b. Guard requirement waivers. Under 33 CFR 126.11, the COTP may waive the requirement for guards on LHG facilities where the stationing of guards is impractical or unnecessary.
- (1) Waivers for guard requirements should only be considered for small transfer facilities that are not manned between transfer operations and do not store bulk liquid hazardous materials on site. Such a facility may be secured by fencing and monitored by intrusion detection devices, cameras, or random patrols rather than permanent guards.
- (2) When reviewing requests for waiver from the guard requirements, the COTP must consider the security barriers and detection devices in place, the likelihood of intrusion, the proximity of population centers, and the danger presented by any tanks or piping containing hazardous materials.
- c. Security barriers. Fences, walls, and similar barriers act as a deterrent to unauthorized entry onto waterfront facilities handling or storing hazardous materials. Buildings, water bodies, ravines, and similar barriers may also be used to deter entry but may need to be augmented by safeguards such as fences, walls, patrols, surveillance cameras, or intrusion detection devices. Security barriers are not specifically required on LHG facilities, but they should be considered when determining the appropriate number of guards under 33 CFR 126.15(a).

---

**8. Records**

Under 33 CFR 126.15(o), LHG facilities must keep certain records and make them available to the COTP. The facility must maintain records of waivers granted by the COTP and equipment tests. The official Coast Guard record for facility information is the MSIS facility file. The COTP must maintain a paper file for each facility in their zone for any facility information that cannot be maintained in MSIS, including a copy of the operations manual, a copy of the worksheet or checklist used during inspections, facility plans or diagrams, and similar information.

---



## SECTION B: DOMESTIC INSPECTION PROGRAMS

## CHAPTER 7: MARINE FACILITIES AND STRUCTURE

**G. PACKAGED AND DRY BULK WATERFRONT FACILITY INSPECTIONS**

---

**1. Applicable Regulations**

Packaged and dry bulk waterfront facilities are regulated under 33 CFR Part 126. These regulations apply to any waterfront facility that handles, stores, stows, loads, discharges, or transports a packaged cargo regulated under 49 CFR Parts 171-179 or a bulk cargo regulated under 46 CFR Part 148. The regulations in 49 CFR Parts 171-179 also apply to facilities handling packaged hazardous materials.

---

**2. Permit to Operate**

- a. General permit. Under 33 CFR 126.2,7 a waterfront facility is automatically issued a general permit to handle, store, stow, load, discharge, or transport a packaged cargo regulated under 49 CFR Parts 171-179 or a bulk cargo regulated under 46 CFR Part 148 (other than division 1.1 and 1.2 explosives).
  - (1) This general permit is issued on the condition that the requirements in 33 CFR 126.15 and 33 CFR 126.27 are met.
  - (2) ,No notice to the Coast Guard is required if an individual decides to operate such a facility.
  - (3) If an operator fails to meet the requirements in 126.15 and 126.27, the COTP may terminate or suspend the general permit to handle dangerous cargo. See MSM Volume VI, Ports and Waterways Activities, COMDTINST M16000.11 (Series), Section 1.H.1 for more information.
- b. Designated dangerous cargo permit. Under 33 CFR 126.17, a waterfront facility may only handle, load, discharge, or transport division 1.1 and 1.2 explosives if the COTP issues a permit or waives the requirement for a permit.
  - (1) The conditions in 33 CFR 126.15 must be met when handling, loading, discharging, or transporting a designated dangerous cargo.

**SECTION B: DOMESTIC INSPECTION PROGRAMS****CHAPTER 7: MARINE FACILITIES AND STRUCTURE**

- (2) A permit is required for each transaction of handling, loading, discharging, or transporting a designated dangerous cargo. The permit automatically terminates at the conclusion of the transaction for which the permit was issued. The permit may be terminated or suspended by the COTP whenever he or she deems it necessary for safety or security reasons. See MSM Volume VI, Ports and Waterways Activities, COMDTINST M16000.11 (Series), Section 1.H.2, for more information.

---

**3. Fire Safety**

The purpose of fire safety on waterfront facilities is to prevent fires and explosions. It also ensures that the resources necessary to respond to a fire are available and in working order should a fire occur. On packaged and dry bulk waterfront facilities the threat of fire stems not only from flammable cargoes but from other flammable articles on the facility such as dunnage, building materials, and rubbish. The following fire safety requirements apply to packaged and dry bulk facilities:

- a. Smoking prohibitions. 33 CFR 126.15(b) prohibits smoking on a waterfront facility except where designated by the owner or operator of the facility.
- (1) On packaged and dry bulk facilities, smoking may only be permitted in accordance with local ordinances and regulations.
  - (2) Where there are no local ordinances, the COTP should ensure that all locations classified as hazardous in NFPA 70 (generally within 15 meters of where flammable hazardous materials are stored) are posted as no smoking areas.
  - (3) Questionable cases should be discussed with local authorities.
  - (4) Under 49 CFR 176.182(f), smoking is prohibited on or near any vessel loading or unloading explosives at a waterfront facility, but may be allowed in designated smoking areas at a safe distance from the vessel.
  - (5) Smoking and no smoking signs must be conspicuously posted. It is not enough for the facility owner or operator to post signs, the restrictions must also be enforced.

## SECTION B: DOMESTIC INSPECTION PROGRAMS

## CHAPTER 7: MARINE FACILITIES AND STRUCTURE

- b. Hot work. Hot work is any welding, burning, cutting, or similar operation that generates heat or sparks that could ignite a flammable material. Prior approval of the COTP is required for such operations under 33 CFR 126.15(c). A hot work permit is the preferred means for giving COTP approval for hot work operations. See MSM Volume VI, Ports and Waterways Activities, COMDTINST M16000.11 (Series), Section 1.H.5, for more information.
- (1) General. The intent of this requirement is to prohibit indiscriminate hot work that could cause a fire or explosion by providing the COTP with authority to regulate such an operation.
- (a) The prime consideration in evaluating hot work requests must be safety. If the degree of safety is questionable, a permit should not be issued. Liaison with local fire authorities is encouraged when evaluating unusual permit requests.
- (b) Permits may be issued for a single day, the duration of a single project, or for a longer period (up to one year) that will cover a number of projects, at the discretion of the COTP.
- (c) In some cases, local or unusual conditions may make some of these requirements unnecessary or not feasible. In these instances, the COTP may use the waiver authority provided by 33 CFR 126.11.
- (d) In other cases, local or unusual conditions may make these requirements inadequate and additional conditions should be added to the permit. Any additional conditions specified by the COTP should be based upon sound safety standards such as NFPA or ANSI standards.
- (e) Welding is prohibited at facilities, or on vessels moored thereto, when explosives are present under 33 CFR 126.15(c). No reference is made to the different classes of explosives; therefore, this condition may be overly restrictive in some cases. In this situation, the COTP may use the waiver authority under 33 CFR 126.11 to maintain an acceptable level of safety without prohibiting reasonable operations on waterfront facilities.
- (2) Enforcement. The hot work permit requirements should be enforced to the maximum extent possible.
- (a) Where practical, hot work permit enforcement may be performed by local fire departments. However, COTP personnel must occasionally verify that the conditions on the permit are being followed, particularly on facilities that have a history of safety violations.

## SECTION B: DOMESTIC INSPECTION PROGRAMS

**CHAPTER 7: MARINE FACILITIES AND STRUCTURE**

- (b) If hot work is in progress during a facility inspection or monitor verify that the facility (or a vessel moored to the facility) has a permit for the hot work and that the conditions of the permit are being met.
- (3) Hot work permits for vessels carrying explosives or other packaged hazardous materials moored at a facility are issued to the vessel under 49 CFR 176.54. Hot work on other vessels moored to a packaged or dry bulk waterfront facility are issued to the facility under 33 CFR 126.15(c).
- (4) References. NFPA has published the following standards for hot work:
  - (a) "Welding and Cutting," NFPA 51.
  - (b) "Welding Processes," NFPA 51B.
  - (c) "Control of Gas Hazards on Vessels to be Repaired," NFPA 306.
- c. Motor vehicles on the pier. Under 33 CFR 126.15(d), transient trucks and automobiles are allowed to remain on the waterfront facility only long enough to load or unload cargo, equipment, supplies, or passengers.
  - (1) If a vehicle is waiting to load or unload, it must be attended by a driver.
  - (2) Vehicle parking on the waterfront facility is permitted only in spaces that are designated for parking and marked off by the facility owner or operator in accordance with local ordinances.
  - (3) The number of vehicles permitted upon the pier or wharf at one time should be limited to permit free traffic flow.
  - (4) Vehicle engines must be stopped when loading and unloading cargo.
  - (5) While on the waterfront facility, filling or draining vehicle fuel tanks or making repairs is prohibited.
- d. Equipment on the pier driven by internal combustion engines. 33 CFR 126.15(e) provides safety requirements for equipment driven by an internal combustion engine that is regularly used on the waterfront facility. Such equipment includes forklifts, generators, and pumps, as well as motor vehicles.
  - (1) The equipment must be kept free from excessive oil, grease, and lint so as not to constitute a fire hazard.

## SECTION B: DOMESTIC INSPECTION PROGRAMS

## CHAPTER 7: MARINE FACILITIES AND STRUCTURE

- (2) Each piece of equipment must carry an approved fire extinguisher unless the equipment is operating in an area where other facility extinguishers are available on the facility, and the COTP has approved the arrangement.
  - (3) Equipment that is not attached to the pier or wharf should not be stored or fueled on the pier or wharf. Such equipment should be stored or fueled in designated areas away from the pier or wharf.
- e. Rubbish and waste materials. The requirements in 33 CFR 126.15(f) address the fire hazards created by poor housekeeping. Inspections for fire hazards should not be limited to obvious areas, but should include out-of-the-way places, as well. Both the insides and outsides of sheds and other buildings should be examined. Hazards and potential hazards that could cause a fire to start or hinder firefighters should be noted and corrected. Inspectors should be alert to--
- (1) Piles of dunnage or scrap;
  - (2) Rubbish or waste materials on piers or wharves;
  - (3) Sloppy carpenter and paint shops, etc.;
  - (4) Railroad cars laden with waste materials;
  - (5) Inadequate or unsuitable waste cans (rubbish should be kept in metal containers with covers, and removed or emptied at frequent intervals to prevent dangerous accumulations); and,
  - (6) Hazardous accumulations of dust on trusses, girders, or other structural members.
- f. Electrical installations. Under 33 CFR 126.15(h), installations of electrical wiring and equipment on packaged and dry bulk facilities made after 28 August 1951 must be in accordance with accepted safe practices.
- (1) Conformance to the National Electric Code and to local ordinances and regulations is considered to meet the safe practices requirement.
  - (2) Electrical equipment, fittings, and other devices must be approved for use by the UL, FM, or CSA.
  - (3) NBS approval is also acceptable under 33 CFR 126.15(h), however NBS no longer issues such approvals.
  - (4) All electrical wiring and equipment, including that installed prior to 28 August 1951, must be maintained in a safe condition without defects or modifications that

## SECTION B: DOMESTIC INSPECTION PROGRAMS

**CHAPTER 7: MARINE FACILITIES AND STRUCTURE**

- could cause a fire or personal injury. Defective or dangerous wiring, equipment, and devices must be replaced, removed or permanently disconnected.
- (5) During inspections and monitors, personnel should look for the following the electrical hazards:
- (a) Conditions which could cause arcing.
  - (b) Electric motors that are--
    - [1] Located too near combustible material;
    - [2] Located in damp places or subjected to corrosive vapors;
    - [3] Covered with rust, lint or dust;
    - [4] Burning out because of overloading or low voltage at motor terminals;
    - [5] Protected by improper overcurrent protection; or,
    - [6] Producing excessive heat.
  - (c) Bare wires.
  - (d) Loose or frayed connections.
  - (e) Overloaded outlets.
  - (f) Corroded terminals.
  - (g) Lack of high voltage signs near transformers and switch boxes.
  - (h) Defective insulation.
- g. Heating methods. Under 33 CFR 126.15(i), heating equipment on packaged and dry bulk facilities must be safely installed and maintained in good operating condition.
- (1) The recommended guide for safe installation of heating equipment is the National Board of Fire Underwriters Building Code.
  - (2) For portable electric heating equipment, approval by CSA, FM, or UL should be used as a guide for safe design, and NFPA 70 should be used as a guide for safe installation.

## SECTION B: DOMESTIC INSPECTION PROGRAMS

**CHAPTER 7: MARINE FACILITIES AND STRUCTURE**

- (3) Adequate clearances must be provided for heating equipment to prevent undue heating of nearby combustible materials.
  - (4) In addition, 33 CFR 126.15(i) requires that spark arresters be provided if the heater uses solid fuel.
  - (5) Open fires in lamps, barrels, drums, or similar apparatus are prohibited.
  - (6) These requirements should be strictly enforced, particularly in areas within 100 feet of a pipe or tank containing flammable products.
  - (7) During inspections, personnel should look for improper heaters in sheds or shelters on the facility.
- h. Maintenance stores and supplies. Under 33 CFR 126.15(g) supplies that are regulated as hazardous materials under 49 CFR Parts 171 through 179 may be kept on designated waterfront facilities only in amounts necessary to meet normal operating requirements. These materials must not be stored on piers or wharves, but in compartments that are remote from combustible materials. The compartments must be designed to provide ready access and safe storage. During inspections, personnel should make sure containers in storage compartments are not leaking or left open so that vapors accumulate in the storage compartment. They should also verify that scrap materials, rags, and other debris are not left in the storage compartment.
- i. Fire extinguishing equipment. Fire extinguishing and protection equipment is essential to the safe operation of any waterfront facility. The quantity, type, and location of equipment required for each facility will vary depending upon the types of hazards present.
- (1) Under 33 CFR 126.15(j), fire extinguishing equipment must be available on each packaged and dry bulk waterfront facility in adequate quantities, locations, and types.
  - (2) Once installed, fire extinguishing and protection equipment must be maintained in good condition at all times.

**SECTION B: DOMESTIC INSPECTION PROGRAMS****CHAPTER 7: MARINE FACILITIES AND STRUCTURE**

- (3) Under 33 CFR 126.15(k) fire appliances such as hydrants, standpipes, fire extinguishers, hose stations, and fire alarm boxes must be conspicuously marked and readily accessible. The color used in marking depends upon local regulations but generally, they are marked in red and their purpose or number shown in white lettering. The markings must be placed high enough that they will not be hidden by cargo, stanchions, columns, risers, or other obstructions.
- (4) All locations of fire appliances should be numbered and indicated on the facility's floor plan.
- (5) The COTP should work with the local fire authority in determining the adequacy of fire equipment. NFPA 307 and NFPA 10 may be used as guides when determining adequacy of that equipment.
- (6) If the fire equipment on a facility is inadequate, the COTP must notify the facility operator of the problem in writing and provide the operator an opportunity to correct the situation.
- (7) During inspections, look for improperly marked fire appliances, material blocking access to fire appliances, and appliances that are not functional (excessive corrosion, missing fire hoses, etc.).

---

**4. Arrangement of Cargoes and Materials**

Cargoes at waterfront facilities must be stowed in an orderly arrangement to permit complete access for firefighting and reduce the risk of fire.

- a. Clear areas. Clear areas are required when stacking or arranging cargo or materials on the waterfront facility or in buildings on the waterfront facility.
  - (1) At least 60 centimeters of clearance must be provided around all stacks or piles of cargo, freight, merchandise, or other materials (33 CFR 126.15(m)(1)). The cleared area must be kept free of rubbish, dunnage, or other obstructions.
  - (2) Around firefighting equipment and fire alarm boxes, the cleared area must be at least 1.2 meters with a straight aisle at least one meter wide leading to the center aisle (33 CFR 126.15(m)(3) and (4)).
  - (3) The main aisle must be at least 2.5 meters wide and at least 6 meters wide if fire truck access is required (33 CFR 126.15(m)(5)).
  - (4) Cross aisles, at least 1.5 meters wide, must be located at least every 23 meters along the facility or within the building (33 CFR 126.15(m)(6)).



## USCG Marine Safety Manual, Vol. II: Materiel Inspection

## SECTION B: DOMESTIC INSPECTION PROGRAMS

## CHAPTER 7: MARINE FACILITIES AND STRUCTURE

- b. **Stacking.** Under 33 CFR 126.15(m)(2), no cargoes, freight, merchandise, or materials may be stacked closer than 90 centimeters from the ceiling of a building or its structural members, nor may they be stacked closer than 30 centimeters from sprinkler heads.
- (1) Packaged cargoes, freight, merchandise, or materials that are flammable or combustible may not be tiered higher than 3.7 meters on the waterfront facility. This includes containers as well as pallets, boxes, paper, etc.
  - (2) This restriction is very broad in scope and is intended to protect older facilities constructed at least partially of wood.
  - (3) The COTP may waive this requirement; however, the safety implications must be carefully considered. The following NFPA standards should be used as guidelines when considering waivers of cargo arrangement and storage requirements:

STANDARD CODE	TITLE
NFPA 231	Indoor General Storage
NFPA 231A	Outdoor General Storage
NFPA 307	Operation of Marine Terminals
NFPA 490	Ammonium Nitrate

## 5. Occupational Safety

The Coast Guard and OSHA share responsibility for the safety of workers on waterfront facilities handling hazardous materials. The Coast Guard's primary responsibility in this area is the safe handling of hazardous materials. Packaged and dry bulk facilities are covered by the OSHA marine terminal regulations in 29 CFR Part 1917. Inspectors should be aware of these OSHA regulations because they may cover safety situations not covered by Coast Guard regulations. The following safety requirements apply to most waterfront facilities:

- a. **Lighting.** To prevent accidents, waterfront facilities must be adequately illuminated when handling hazardous materials during periods of darkness.
  - (1) 33 CFR 126.15(l) requires adequate lighting for packaged and dry bulk facilities. This section does not require a specific lighting intensity; however, lighting intensity should meet the OSHA requirements in 29 CFR 1917.123. This regulation requires lighting of at least 55 lux in each active work area, at least 11 lux in other work areas, and at least 5 lux for security purposes.
  - (2) Measurements of light intensity should, if possible, be made with a light meter.

**SECTION B: DOMESTIC INSPECTION PROGRAMS****CHAPTER 7: MARINE FACILITIES AND STRUCTURE**

- (3) Lights should be installed over aisles and in other locations where they will not be damaged by vehicle movements or cargo handling.
  - (4) Light fixtures should be protected by wire guards unless mounted out of the normal reach of equipment and personnel.
  - (5) Open flame lights and lanterns using kerosene or gasoline are prohibited.
  - (6) Temporary lighting, when required, must be obtained from battery powered hand lamps or protected electric lamps that are energized from portable electric generators, located outside of the building or off the pier.
- b. Cargo handling equipment. No specific Coast Guard requirements have been set for cargo handling equipment on packaged or dry bulk facilities; however, OSHA has set the following requirements:
- (1) Cargo slings must meet the requirements in 29 CFR 1917.13.
  - (2) Ropes, chains, blocks, and hooks must meet the requirements in 29 CFR 1917.42.
  - (3) Powered industrial trucks must meet the requirements in 29 CFR 1917.43.
  - (4) Conveyors must meet the requirements in 29 CFR 1917.48.
  - (5) Spouts, chutes, hoppers, bins and similar equipment must meet the requirements in 29 CFR 1917.49.
- c. Warning alarms. Packaged or dry bulk facilities that handle division 1.1 or 1.2 explosives, oxidizing material or blasting agents requiring a permit (primarily ammonium nitrates), or highway route controlled quantities of radioactive material are considered facilities of particular hazard.
- (1) 33 CFR 126.16(b) requires these facilities to have warning alarms. Warning alarms are intended to alert approaching vessels and the local community in the event of an imminent explosion or radioactive release.
  - (2) Each facility of particular hazard must have either a siren or a rotating flashing light that can be heard or seen at least 1 mile away.
  - (3) The color of the rotating flashing light is not prescribed, however, amber is recommended because it is considered most effective in alerting personnel to a hazard.

## SECTION B: DOMESTIC INSPECTION PROGRAMS

## CHAPTER 7: MARINE FACILITIES AND STRUCTURE

- (4) The adequacy of warning alarms should be verified during the annual facility inspection by activating the alarm while a member of the inspection team, located 1,600 meters away, determines if it can be seen or heard. Inspectors should be particularly alert to obstructions that could prevent a warning light from being seen from the waterway.

---

## 6. Security

- a. Guards. Trained guards are required in sufficient numbers to provide surveillance of the waterfront facility to deter unlawful entry, deter vandalism, detect fire hazards, detect discharges of hazardous materials, and check the readiness of protective equipment.
  - (1) Guards should be thoroughly instructed in the operation of fire alarm boxes, fire hoses, portable fire extinguishers, and similar fire equipment. They should know the location of telephones and emergency equipment, emergency fire protection measures, and emergency notification procedures.
  - (2) The NFPA has developed two standards applicable to guards that may be used in determining the adequacy of guards required under 33 CFR 126.15(a): Guard Service - NFPA 601, and Guard Operations - NFPA 601A.
  - (3) When determining whether the number of guards provided is adequate for a facility, the COTP should consider the security barriers and detection devices in place.
  - (4) If the guards are found to be inadequate, the COTP must notify the facility operator of the problem in writing and provide the operator an opportunity to correct the situation.
- b. Guard requirement waivers. Under 33 CFR 126.11, the COTP may waive the requirement for guards on packaged and dry bulk facilities where the stationing of guards is impractical or unnecessary.
  - (1) Waivers for guard requirements should only be considered for small transfer facilities that do not store large quantities of hazardous materials on site. Such a facility may be secured by fencing and monitored by intrusion detection devices, cameras, or random patrols rather than permanent guards.

**SECTION B: DOMESTIC INSPECTION PROGRAMS****CHAPTER 7: MARINE FACILITIES AND STRUCTURE**

- (2) Before approving waivers from the guard requirements, the COTP must consider the security barriers and detection devices in place, the likelihood of intrusion, the proximity of population centers, and the danger presented by hazardous materials stored at the facility.
- c. Security barriers. Fences, walls, and similar barriers act as a deterrent to unauthorized entry onto waterfront facilities handling or storing hazardous materials. Buildings, water bodies, ravines, and similar barriers may also be used to deter entry but may need to be augmented by safeguards such as fences, walls, patrols, surveillance cameras, or intrusion detection devices. Security barriers are not specifically required on waterfront facilities, but they should be considered when determining the appropriate number of guards under 33 CFR 126.15(a).

---

**7. Records**

Packaged and dry bulk waterfront facilities are not required to maintain records for the Coast Guard, but should keep Coast Guard inspection reports for their facility and make such reports available to future Coast Guard inspectors. The official Coast Guard record for facility information is the MSIS facility file. The COTP must have a paper file for each facility in the zone to maintain any facility information that cannot be maintained in MISLE including a copy of the worksheet or checklist used during inspections, facility plans, photographs, diagrams, and similar information.

---

**H. ENTRY ONTO PRIVATE PROPERTY****1. General**

Entry into private property that is part of a shoreline adjoining U.S. waters may be necessary to undertake immediate response activities and subsequent investigations, and to perform inspections to ensure compliance with regulations. In Commandant (G-LMI) memo 5800 of 25 September 1972, the Chief Counsel of the Coast Guard determined that, in general, Coast Guard personnel have the authority to enter private property on or near navigable waters without a warrant to carry out discharge response activities and related investigations or inspections, and may also conduct warrantless administrative inspections where the property is subject to regulation concerning pollution prevention and hazardous materials.

---

**SECTION B: DOMESTIC INSPECTION PROGRAMS****CHAPTER 7: MARINE FACILITIES AND STRUCTURE****2. Access Authorized**

Inspections should be conducted on a prearranged basis whenever practical, with a representative of the owner or operator accompanying the inspection team. Monitors should be conducted without advance notice while a transfer is in progress. Industry members have, historically, responded to the Coast Guard's needs by permitting inspection personnel almost unlimited access to their property. It is a rare occasion when a Coast Guard member is turned away at the gate.

**3. Access Denied**

When this occurs, the COTP/OCMI must determine what actions are appropriate. If a search warrant is considered necessary, the district commander (dl) should be contacted for assistance. Force must not be used in non-emergency situations. The COTP should point out to an owner who refuses entry to his or her property that:

- a. A packaged, dry bulk, or liquefied hazardous gas facility's general permit may be revoked if an inspection is not completed. Without an inspection, there can be no verification that the facility or structure is entitled to a permit to continue operations. For the relevant regulations, see 33 CFR 126.31 and 160.109.
- b. Vessels may be prohibited from mooring at the facility, to prevent possible damage to the vessel brought about by hazardous conditions. A vessel already moored may be required to depart the facility for the same reason. For the relevant regulations, see 33 CFR 160.111.

**I. CORRECTIVE ACTIONS AND PENALTY AUTHORITY****1. Corrective Actions**

Effective corrective actions are necessary to deter repeat discrepancies that endanger lives, property, and the environment. At a minimum, the discrepancy must be corrected. Additional actions provide a greater incentive for future compliance. Each discrepancy found and each corrective action taken must be documented in MISLE. The COTP must select an appropriate action for each discrepancy depending upon the seriousness of the discrepancy and the facility operator's history of compliance. MSM Volume I, Administration and Management, COMDTINST M16000.6 (Series), Chapter 4, provides additional guidance on selecting appropriate actions. If a civil penalty is selected, the COTP must recommend an appropriate penalty using the guidance found in Civil Penalty Procedures and Administration,

**SECTION B: DOMESTIC INSPECTION PROGRAMS****CHAPTER 7: MARINE FACILITIES AND STRUCTURE**

COMDTINST 16200.3A. For each discrepancy found, one or more of the following actions may be taken:

- a. On-the-spot correction.
- b. Violation case: COTP Letter of Warning issued.
- c. Violation case: Forwarded to district commander for civil penalty action. (By law, all violations of 49 CFR Parts 171-179 requirements must be forwarded for civil penalty action by the District Commander.)
- d. COTP Order (to suspend transfer, prohibit vessels from mooring at facility, etc.).
- e. Action against a facility's Letter of Adequacy or General Permit.
- f. Referral to a U.S. Attorney for prosecution (in extreme cases).

---

## **2. Penalty Authority**

The correct penalty authority must be cited when developing a violation case. The appropriate penalty authorities are listed below. Further guidance on appropriate penalties for violation cases is contained in Civil Penalty Procedures and Administration, COMDTINST 16200.3A.

- a. Bulk liquefied natural gas waterfront facilities. The regulations in 33 CFR Part 127 are issued under the statutory authority of the PWSA. Violations are subject to the civil and criminal penalties under 33 U.S.C. 1232. The maximum civil penalty is \$25,000 per violation and each day of a continuing violation constitutes a separate violation.
- b. Bulk liquefied hazardous gas waterfront facilities. The regulations in 33 CFR Part 126 are issued under the statutory authority of the PWSA. Violations are subject to the civil and criminal penalties under 33 U.S.C. 1232. The maximum civil penalty is \$25,000 per violation and each day of a continuing violation constitutes a separate violation.
- c. Dry bulk waterfront facilities. The regulations in 33 CFR Part 126 are issued under the statutory authority of the PWSA. Violations are subject to the civil and criminal penalties under 33 U.S.C. 1232. The maximum civil penalty is \$25,000 per violation and each day of a continuing violation constitutes a separate violation.

## USCG Marine Safety Manual, Vol. II: Materiel Inspection

**SECTION B: DOMESTIC INSPECTION PROGRAMS****CHAPTER 7: MARINE FACILITIES AND STRUCTURE**

- d. Packaged hazardous material waterfront facilities. These facilities are also regulated under 33 CFR Part 126 and violations of those requirements are subject to the civil and criminal penalties under 33 U.S.C. 1232. Packaged hazardous materials are also subject to the requirements in 49 CFR Parts 171-179, which are issued under the HMTA. Those violations are subject to the penalties under 49 U.S.C. 1809, which provides for a maximum civil penalty of \$25,000 per violation or possible criminal prosecution. The law requires a minimum penalty of at least \$250 per violation. Therefore, all violations of the 49 CFR Parts 171-179 requirements must be forwarded for civil penalty action by the District Commander.
- 
-

**SECTION B: DOMESTIC INSPECTION PROGRAMS****CHAPTER 9: ALTERNATE COMPLIANCE PROGRAM****A. INTRODUCTION**

Title 46 U.S.C. Chapter 33 requires that certain vessels possess a Certificate of Inspection (COI). Owners of U.S. vessels may receive a COI by one of three means--

- a. The traditional means of having a Coast Guard Marine Inspector conduct an examination;
- b. Participating in the Streamlined Inspection Program (SIP); or
- c. Participating in the Alternate Compliance Program (ACP).

The ACP maintains existing levels of safety while eliminating duplicative plan review and inspection tasks traditionally conducted by both the classification society and the Coast Guard. Owners of certain U.S. tank vessels, passenger vessels, freight vessels, tank vessels, offshore supply vessels, miscellaneous vessels, (including integrated/articulated tugs and barges, vessels built and inspected to the High Speed Craft Code (HSC)), and Mobile Offshore Drilling Units (MODUs) may elect to enroll in the ACP as an alternate method for vessel design, inspection, and certification. New vessel categories may be added through the regulatory process. Check the ACP Website for the most up-to-date information at [www.uscg.mil/hq/g-m/mse/acp/acp.htm](http://www.uscg.mil/hq/g-m/mse/acp/acp.htm) U.S. and foreign classification societies may be designated as an ACP classification society (see definitions below). The ACP should not be confused with a "Qualship" type program, as it is merely an alternative to traditional inspection standards.

---

---

**B. AUTHORITY**

Title 46 U.S.C. 3316 allows the Coast Guard to delegate certain U.S. merchant vessel plan review, new construction, and periodic inspection to the American Bureau of Shipping (ABS) or another classification society recognized by the Secretary as meeting acceptable standards for such a society. Title 46 CFR Part 8 provides detailed regulations for the ACP. Additional guidance can be found in Navigation and Inspection Circular (NVIC) 02-95, Change 2, The Alternate Compliance Program (<http://www.uscg.mil/hq/cg5/nvic/1990s.asp#1995>).

---

---

**C. DEFINITIONS****1. ACP Officer**

The person tasked by the Officer in Charge, Marine Inspection (OCMI) with the routine coordination and administration of the ACP at the local Coast Guard field unit maintains contact with the local ACP classification society offices, enrolled vessel owners, operators and their designated representatives, and other relevant parties to verify that delegated activities are being performed at the intervals and in the manner prescribed by the terms of the ACP. The ACP Officer designation should be made in writing.



**2. Annual Examination**

The Coast Guard's annual oversight examination verifies classification society adherence to the ACP, evaluates crew performance, and verifies materiel safety. The COI is typically renewed or endorsed during the annual examination.

---

**3. Authorized Classification Society (ACS)**

An Authorized Classification Society (ACS) is a recognized classification society (46 CFR Part 8), that has been delegated the authority to conduct certain functions and certifications on U.S. flagged vessels on behalf of the Coast Guard. The classification society must enter into an agreement with the Coast Guard for individual certificate authorizations (load line, tonnage, safety construction, etc). An ACS may receive the additional ACP authorization (as a "ACP ACS") from Commandant (CG-5P) after satisfactorily performing certain prescribed functions for at least two years. A current list of ACSs may be found on the Web at [www.uscg.mil/hq/g-m/mse/acp/acp.htm](http://www.uscg.mil/hq/g-m/mse/acp/acp.htm)

---

**4. Class Rules**

Class Rules are standards developed and published by a classification society and are for the design, construction, and certification of commercial vessels.

---

**5. Classification Society's ACP Coordinator**

The individual appointed by a classification society acts as a central point of contact for matters involving the ACP and functions delegated by the Coast Guard.

---

**6. Delegated Function**

Delegated function is related to the Coast Guard commercial vessel inspection program that has been delegated to a classification society. Delegated functions may include issuing international convention certificates and/or examinations necessary to participate in the ACP.

---

**7. Enrolled Vessel**

An enrolled vessel is enrolled in the ACP.

---

**SECTION B: DOMESTIC INSPECTION PROGRAMS****CHAPTER 9: ALTERNATE COMPLIANCE PROGRAM****8. LORACS**

LORACS is the Coast Guard's Liaison Office for Recognized and Authorized Classification Societies. The LORACS function is administered by the Coast Guard Headquarters Office of Commercial Vessel Compliance, Commandant (CG-CVC-1).

---

**9. Program Manager**

Coast Guard Headquarters, Office of Commercial Vessel Compliance, Commandant (CG-CVC-1) is the Program Manager. The Program Manager is tasked with arranging certain oversight activities ensuring overall ACP administration, and policy development of the ACP.

---

**10. Periodic Oversight Re-Examination**

Periodic oversight re-examination is additional Coast Guard oversight in between annual examinations initiated either by the OCMI or directed via Commandant (CG-CVC) risk assessments.

---

**11. Recognized Classification Society**

A classification society recognized by the Coast Guard meets minimum standards for general characteristics and performance of a quality classification society. This is the first step in becoming an ACS.

---

**12. Streamlined Inspection Program (SIP)**

The SIP provides another alternative for owners and operators to comply with Coast Guard inspection requirements. The ACP and SIP are entirely separate and independent programs. No vessel may be enrolled in both programs simultaneously.

**NOTE:** See MSM Volume II, Materiel Inspection, COMDTINST M16000.7A (Series), Chapter B10 on SIP, and NVIC 2-99 Part A and Part B for complete information on SIP implementation. Also, information on SIP can be accessed from the SIP Web site at: <https://homeport.uscg.mil/mycg/portal/ep/browse.do?channelId=-18346>.

---

---

## D. ACP AUTHORIZED CLASSIFICATION SOCIETY

---

### 1. ACP Approval Process

A list of classification societies and their authorizations may be found on the Web at [www.uscg.mil/hq/g-m/mse/acp/acp.htm](http://www.uscg.mil/hq/g-m/mse/acp/acp.htm).

Before being considered for ACP authorization, an ACS must meet the minimum standards of 46 CFR Part 8.230 listed below.

To obtain ACP authorization, a classification society must--

- a. Be ISO 9000 (or equivalent) compliant;
- b. Become a recognized classification society;
- c. Be delegated an international certificate issuing authority as an ACS;
- d. Complete a minimum 2-year probationary period as an ACS;
- e. Develop a U.S. supplement;
- f. Obtain U.S. supplement approval by Commandant (CG-ENG); and
- g. Be accepted as an ACP ACS participant.

**NOTE:** ACP is an additional separate authorization granted to an ACS that has been authorized to issue at least all of the following certificates to a U.S. vessel: International Load Line Certificate, SOLAS Cargo Ship Safety Equipment Certificate, SOLAS Cargo Ship Safety Construction Certificate, IOPP (MAROPOL) Certificate, and International Tonnage Certificate.

### 2. U.S. Supplement

Prior to being delegated the authority necessary to participate in the ACP, the classification society must develop a U.S. supplement or other document that incorporates specific Coast Guard requirements not covered in its class rules or international convention. These requirements include all standards applicable for issuing a COI that are not addressed by either the class rules of that classification society or by applicable international conventions. Development of a U.S. supplement for each ACP classification society ensures that the class rules, when combined with standards in applicable international conventions, provide a level of safety standards equivalent to traditional Coast Guard regulatory requirements. Commandant (CG-ENG) is the approving authority for each U.S. supplement.

**SECTION B: DOMESTIC INSPECTION PROGRAMS****CHAPTER 9: ALTERNATE COMPLIANCE PROGRAM**

U.S. supplements are not necessarily inclusive of all vessel types. An ACS may only engage in ACP compliance for vessel types (certificated under certain Subchapters of 46 CFR) for which they have an approved U.S. supplement. The U.S. supplement that was used when the vessel was enrolled must be used for the vessel's entire operational life (except for major modifications or conversions).

- a. High speed craft (HSC). HSC may enroll in the ACP if their ACS has established rules for HSC and is authorized for the subchapters of 46 CFR for which the vessel would be certificated. In this case, vessels may be inspected to the ACP standard using the International HSC Code, classification society rules, and the most current HSC NVICs (as a universal supplement). A vessel may be enrolled if it holds a HSC Safety Certificate, a Permit to Operate HSC, a Record of Equipment for HSC, as well as other applicable International Certificates (e.g., International Oil Pollution Prevention Certificate, Safety Management Certificate, etc.).
- b. Integrated and articulated tugs and barges. Integrated and Articulated Tugs and Barges (ATB\ITB) may enroll in the ACP. ATBs and ITBs must, in addition to the criteria above, be inspected using an approved U.S. supplement which specifically addresses the barge/tug connection system and the most current ITB NVIC. Further, only ATBs and ITBs designated as "Pushing Mode" in accordance with NVIC 2-81, Change 1 (<http://www.uscg.mil/hq/cg5/nvic/1980s.asp#1981>) and subsequently required by their COI to be operated in a combined configuration may be enrolled in the ACP. The ACP does not apply to barges that are not part of an articulated or integrated unit.
- c. Inspection intervals. As a general rule for ACP vessels, the frequency of survey intervals will be governed by the U.S. interpretation of international conventions or the classification society's intervals for items such as inspection of pressure vessels, stern tube lube oil analysis, boiler safety valves, fuel tank internals, water tube boiler hydrostatic tests, and sea valve internal structural examinations, drydockings (annual for passenger vessels), etc.

---

### 3. International Certificates

Under the ACP regime, the classification society should issue all international certificates for which they have authorization, except those that the Coast Guard cannot delegate (i.e., International Ship Security Certificate/Continuous Synopsis Record). Public vessels may satisfy international convention certificate requirements with Statements of Voluntary Compliance issued by the classification society. International Safety Management (ISM) documentation should typically be issued by the same ACS that is used for the ACP, but that is not a requirement. ISM services may be provided by a different ACS. A classification society may be delegated the authority to issue the following international convention certificates on behalf of the Coast Guard:

**SECTION B: DOMESTIC INSPECTION PROGRAMS**

**CHAPTER 9: ALTERNATE COMPLIANCE PROGRAM**

- a. International Load Line Certificate.
- b. International Tonnage Certificate.
- c. SOLAS Cargo Ship Safety Construction Certificate.
- d. SOLAS Cargo Ship Safety Equipment Certificate.
- e. International Certificate of Fitness for the Carriage of Dangerous Chemicals in Bulk.
- f. International Certificate of Fitness for the Carriage of Liquefied Gases in Bulk.
- g. IMO Mobile Offshore Drilling Unit Safety Certificate.
- h. MARPOL 73/78 International Oil Pollution Prevention Certificate.
- j. MARPOL 73/78 International Pollution Prevention Certificate for the Carriage of Noxious Liquid Substances in Bulk.
- k. SOLAS Passenger Ship Safety Certificate.
- l. High-Speed Craft Safety Certificate.
- m. MARPOL 73/78 International Air.
- o. ISM Code Document of Compliance (issued to operating company office).
- p. ISM Code Safety Management Certificate (issued to vessel).

## USCG Marine Safety Manual, Vol. II: Materiel Inspection

## SECTION B: DOMESTIC INSPECTION PROGRAMS

## CHAPTER 9: ALTERNATE COMPLIANCE PROGRAM

MARPOL 1 ANNEX	ANNEX FULL TITLE	CLASSIFICATION SOCIETY AUTHORIZATION STATUS
Annex I	Regulations for the Prevention of Pollution by Oil.	Full authorization.
Annex II	Regulations for the Control of Pollution by Noxious Liquid Substances in Bulk.	Full authorization.
Annex III	Regulations for the Prevention of Pollution by Harmful Substances Carried by Sea in Packaged Form.	Full authorization (see note 2 below).
Annex IV	Regulations for the Prevention of Pollution by Sewage from Ships.	Limited authorization (see note 3 below).
Annex V	Regulations for the Prevention of Pollution by Garbage from Ships.	Full authorization (No certificate).
Annex VI	Regulations for the Prevention of Air Pollution from Ships.  International Air Pollution Prevention Certificates & Supplements.  Engine International Air Pollution Prevention Certificates (This is issued by the Environmental Protection Agency (EPA)).	Full authorization

**NOTE 1:** Only Commandant (CG-CVC) may approve extensions for certificates issued under international conventions.

**NOTE 2:** The Coast Guard's policy has been to endorse the COI with a statement that the vessel complies with MARPOL Annex III (where applicable) in lieu of issuing a separate certificate. However, some foreign port States (Italy in particular) demand a separate certificate, even though MARPOL does not specify that a separate certificate is required or even available. U.S. owners who desire a MARPOL III Statement of Compliance may obtain one from an ACS.

**NOTE 3:** See Commandant (CG-CVC) NVIC 01-09 ([http://www.uscg.mil/hq/cg5/nvic/pdf/2009/NVIC\\_1-09.pdf](http://www.uscg.mil/hq/cg5/nvic/pdf/2009/NVIC_1-09.pdf)). The United States is not signatory to MARPOL 73/78, ANNEX IV, therefore U.S. vessels may comply with the marine sanitation device standards in 33 CFR Part 159 or may comply with MARPOL 73/78, ANNEX IV. See NVIC 01-09. An ACS may issue Statements of Voluntary Compliance if the vessel fully meets Annex IV requirements.

**SECTION B: DOMESTIC INSPECTION PROGRAMS****CHAPTER 9: ALTERNATE COMPLIANCE PROGRAM****4. Certificate Revocation**

Class surveyors should make recommendations to the OCMI to revoke/rescind international certificates for significant or numerous deficiencies to lifesaving, firefighting, watertight integrity, and pollution prevention materiel and equipment. (Refer to "Operational Control Actions and Detentions," which are discussed later in this chapter.)

---

**E. TRANSFER OF CLASS**

Vessels enrolled in the ACP may transfer to another classification society with the ACP authorization with prior Commandant (CG-CVC) approval. The transfer must be completed in accordance with IACS Procedural Requirement No. 1A, which may be found at <http://www.iacs.org.uk/publications/default.aspx>. In addition, the application procedures for new entries will be completed including completion of a hand-over survey attended by the gaining classification society surveyor, the losing classification society surveyor and a Coast Guard marine inspector. Upon transfer of class, Marine Information for Safety and Law Enforcement database (MISLE) entries must be made as discussed in Q.4 of this Chapter.

---

**1. Gap Analysis**

Before the hand-over survey, the gaining classification society is responsible for completion of a thorough gap analysis to determine variations between the two societies' rules and U.S. supplements with regard to the vessel. This analysis will be documented and submitted to Commandant (CG-ENG) for review and approval at least 30 days before the transfer of class. A comprehensive list of plans should accompany the gap analysis for administrative use. Specific plans should be provided upon Coast Guard request to facilitate gap analysis oversight as required. After the transfer of classification societies, the vessel will be inspected using the gaining classification society's rules, the gaining classification society's U.S. supplement, and international conventions. Marine inspectors should pay particular attention to potential disparities between classification society U.S. supplements to avoid regulatory gaps during the transfer inspection.

---

**F. INSPECTION ACTIVITIES RETAINED BY THE COAST GUARD**

The Coast Guard retains authority for the following marine inspection activities:

- a. All manning issues (including the determination of eligibility for reduced manning based upon a classification society-approved automation system).
- b. Marine casualty investigations and analysis.
- c. Drydock interval extensions beyond 90 days.

**SECTION B: DOMESTIC INSPECTION PROGRAMS****CHAPTER 9: ALTERNATE COMPLIANCE PROGRAM**

- d. Approval of a vessel's participation in the Under Water Survey in Lieu of Drydocking (UWILD) Program.
- e. Permits to Proceed.
- f. Load Line exemptions.
- g. Excursion permits.
- h. Changes of employment.
- i. Critical Area Inspection Plan (CAIP) enrollment and exams.
- j. Waivers, exemptions or equivalencies to international conventions; (examples: load line, SOLAS, and MARPOL).
- k. Alternative compliance with 72 COLREGS.
- l. Extensions for convention certificates.
- m. Approval of security plans.
- n. Approvals of safety equipment, materials, installations, and qualifications required by 46 CFR Part 2.75.
- o. Continuous Synopsis Records (CSR).
- p. International Ship Security Certificates (ISSC).
- q. Major conversion determinations.
- r. Ballast water management compliance and enforcement.

---

**1. Marine Casualties**

The Coast Guard retains all marine casualty investigation functions including machinery automation failures. ACP enrolled vessels must properly notify the Coast Guard of all reportable marine casualties. The vessel's master is responsible for making initial notification of a casualty to the Coast Guard, and for preparing and submitting a Report of Marine Accident, Injury, or Death (Form CG-2692) to the cognizant OCMI. Class surveyors may complete a damage survey and make repair recommendations, however, the OCMI retains authority to review and approve repair proposals, as an oversight option. Surveyors should notify the OCMI if a vessel fails to satisfactorily complete automation testing since manning levels could be affected. Refer to 46 CFR 62.50 for requirements. Multiple equipment or



**SECTION B: DOMESTIC INSPECTION PROGRAMS****CHAPTER 9: ALTERNATE COMPLIANCE PROGRAM**

system failures could indicate Safety Management System (SMS) discrepancies. Materiel and crew deficiencies should trigger at least a cursory "SMS review" of the particular system which has apparent non-conformities.

---

**G. VESSEL ENROLLMENT**

---

**1. Application**

A vessel owner or operator wishing to have a vessel certificated under the ACP may apply by submitting an Application for Inspection of U.S. Vessel, Form CG-3752 to the cognizant OCMI. The form must indicate the owner's desire to enroll the vessel in the ACP and designate an ACS. The vessel must be in compliance with the ACS's class rules, U.S. supplement, and applicable international maritime safety and pollution prevention conventions. Special care should be taken to ensure that Maritime Security Program (MSP) vessels are not inadvertently enrolled in the ACP. While an MSP vessel is eligible to enroll, the vessel does not need to develop or meet the U.S. supplement standards. Therefore, a vessel typically cannot comply with both the MSP and ACP standards at the same time. A vessel should not have both MSP and ACP endorsements on the COI.

**NOTE:** Vessels need not be on dedicated international voyages to qualify for the ACP. The intent, rather, is to ensure that the vessels meet the standards required for international certification.

a. Pre-requisites. Enrolled vessels must--

- (1) Have a valid COI;
- (2) Be "classed" by an ACP ACS (generally, a valid certificate for hull and machinery issued by the classification society is evidence that a vessel is "classed");
- (3) Be subject to international conventions and have valid international certificates; and
- (4) The vessel must not qualify for involuntary disenrollment as described in H.1 of this Chapter.

**NOTE:** For new construction, Commandant (CG-CVC) may enroll vessels into the ACP while they are in the process of obtaining all of the above.

- b. Novel design prohibitions. Vessels with novel or especially complex designs or operations, for which the classification society has no rules approved by the Coast Guard and/or the Coast Guard has no regulations or policies developed for a particular application, are not to be permitted to enroll in the ACP. For new

**SECTION B: DOMESTIC INSPECTION PROGRAMS****CHAPTER 9: ALTERNATE COMPLIANCE PROGRAM**

construction, re-flags, and major conversions, Commandant (CG-CVC) will consult with the Marine Safety Center (MSC) to make novel design determinations before enrollment. The MSC will make recommendations to Commandant (CG-CVC) within five working days of receiving the request.

- c. Meeting with MSC. The owner or its agent should schedule a meeting with the MSC after the Application for Inspection has been submitted.
    - (1) Discussion of the gap analysis with the owner's representative and the ACS, if one is being used, must be conducted in order to identify major issues at the beginning of the project. Points of contact should be agreed upon during the meeting so that all information during the process is directed to the correct parties.
    - (2) If the vessel is to be enrolled in the ACP, the point of contact on behalf of the USCG will be the ACS authorized to participate in the ACP. The purpose of the meeting is to identify problem areas early in the plan review process, verify the applicable vessel inspection alternative standards for the certification, and reduce the possibility that vessel certification will be delayed. In addition, members of the Commandant (CG-CVC) and other Headquarters staff may attend the meeting to address any policy issues pertinent to the process.
  - d. Oversight Plan. An Oversight Plan is highly recommended for any ACP enrollment involving modifications/conversions, new construction projects and passenger vessel enrollments. The representatives for the ACS and the OCMI must meet at the beginning of the project to establish the oversight plan. Further information and templates for the plan can be found in the Enclosure 1 of the reflag NVIC 10-81 CH1.
  - e. New construction and major conversions. New construction projects and major conversions will be provisionally enrolled at the beginning of construction pending successful construction and plan review oversight, as well as completion of all required certificate issuance and final hand-over survey. A second application must be made to the OCMI near the end of construction to schedule a final hand-over survey. For new construction or major conversions, a list of plans must be submitted to the MSC electronically via the Electronic Correspondence link on the MSC's Web site (<http://www.uscg.mil/hq/msc/>). Vessels may not be enrolled until the list of plans is received by the MSC. The MSC's Marine Technical Note 04-03 (series) and the reflag NVIC 10-81 CH1 provide in depth information on plans required to be submitted.
-

**SECTION B: DOMESTIC INSPECTION PROGRAMS****CHAPTER 9: ALTERNATE COMPLIANCE PROGRAM****2. Eligibility and Data Transfer**

Once the OCMI determines that a vessel meets the criteria for enrollment, a copy of the vessel's MISLE record (COI and the critical profile) and a copy of the Inspection of U.S. Vessels, CG-3752 should be sent to the designated ACP Classification Society Coordinator by the OCMI. Contact the LORACS for assistance if needed at (202) 372-1233.

---

**3. Processing**

The ACP Classification Society Coordinator enters the appropriate MISLE details into the vessel's class computer record, including outstanding deficiencies and special notes. When the computer details are correct, arrangements should be made for the hand-over survey. Follow-up between the involved parties is encouraged to ensure that the data is properly transferred.

---

**4. Hand-Over Survey**

The ACS surveyor and a Coast Guard marine inspector will jointly conduct the hand-over survey. The survey will consist of the mandatory annual survey required for the Cargo Ship Safety Construction Certificate, the Cargo Ship Safety Equipment Certificate and the International Oil Pollution Prevention Certificate. Any certificate renewal, annual endorsements, or annual class surveys should be completed as part of the hand-over survey whenever possible.

All Coast Guard issued convention certificates will be withdrawn and class issued certificates issued in their place. Class surveyors are familiar with this process of certificate conversion that is commonplace during a transfer of class. It is expected that the owner's representative will try to schedule the hand-over survey at a time that harmonizes with the vessel's window of surveys. The inspector and the surveyor must co-sign or endorse any certificates on board with the exception of the COI, which is signed, issued and endorsed only by the Coast Guard. The hand-over survey should be detailed enough to ensure that any nuances or unique compliance aspects are thoroughly understood by both the class surveyor and the Coast Guard inspector. After completion of a hand-over survey, the OCMI should notify Commandant (CG-CVC) of the success or failure of the survey.

- a. Major non-conformities during hand-over survey. If, during the hand-over survey, ISM Code major non-conformities are discovered, the vessel will not be enrolled in the ACP. Instead, the deficiencies must be corrected as per normal Coast Guard policy. An external shipboard audit must be directed and observed by the OCMI. In addition, the cognizant OCMI should attend the external auditor's follow-up audit not later than 90 days after the original hand-over survey. Commandant (CG-CVC) must be notified if major non-conformities in the SMS are discovered during a hand-over survey.

**SECTION B: DOMESTIC INSPECTION PROGRAMS****CHAPTER 9: ALTERNATE COMPLIANCE PROGRAM**

- b. Any vessel denied entry into the program due to the discovery of major non-conformities during the hand-over survey will remain in the traditional inspection program for an additional calendar year. The vessel may reapply after one year. The hand-over survey will be conducted with emphasis on the vessel's SMS. It is intended that the company use the additional year to bolster and enhance their SMS.

---

**5. Notification of Enrollment**

- a. OCMI's must notify Commandant (CG-CVC-1) via most expeditious means (preferably faxed or e-mailed signed endorsement memo) of the results of the hand-over survey and recommendations regarding ACP enrollment. Correspondence should include--
- (1) The vessel's name and official number;
  - (2) The ACS;
  - (3) The CFR subchapter for which an alternate standard will be applied;
  - (4) The OCMI's recommendation regarding suitability for the ACP;
  - (5) The mailing address of the requesting party; and
  - (6) A specific point of contact for the requesting party.
- b. A copy of the vessel's Application for Inspection should also be forwarded to the MSC at the same time so they may start a vessel oversight file.
- c. Commandant (CG-CVC) notifies the vessel's owner by letter (with a copy to the classification society's ACP Coordinator, the OCMI, the MSC, and the LORACS) of the vessel's enrollment into the ACP (see MISLE entries noted in O of this Chapter).

---

**H. VESSEL DISENROLLMENT**

---

**1. Involuntary Disenrollment**

- a. The Program Manager Commandant (CG-CVC) must consider an ACP enrolled vessel for disenrollment after notification of one or more of the following:
- (1) Revocation of the vessel's COI.

**SECTION B: DOMESTIC INSPECTION PROGRAMS****CHAPTER 9: ALTERNATE COMPLIANCE PROGRAM**

- (2) Revocation or ineligibility for any of the required International Convention Certificates.
- (3) Notification of removal of the enrolled vessel from Class.
- (4) A recommendation from the ACP ACS to disenroll the vessel.
- (5) A pattern of two or more Port State Control (PSC) detentions or U.S. operational controls (e.g., COTP or "No Sail" Vessel/Facility Inspection Requirements, CG-835s for critical systems) within a 12 month period.

**NOTE:** Only Commandant (CG-CVC) can make involuntary disenrollment determinations for vessels. Commandant (CG-CVC) must carefully compare Port PSC detentions against the definitions of International Safety Management Code "major non-conformity."

Caveat - Vessels detained by sovereign port States for isolated incidents (oil in the bilges or deficiencies caused by an act of God for which the vessel has not had the opportunity to address) which under current Coast Guard Policy may not have resulted in an Operational Control, may be downgraded by Commandant (CG-CVC).

- b. The ACP seeks to achieve the same goal as Coast Guard inspections, i.e. consistent compliance with minimum regulatory safety and environmental standards. Although the majority of ACP vessels exceed the minimum standards, this performance is not required by law or regulation, and is therefore also not required under the ACP. Vessels that would be eligible for a Coast Guard COI by meeting minimum standards are equally eligible to enroll in the ACP. However, vessels that consistently fail to address substandard conditions, habitually pollute, or are subjected to repeated operational controls both in the United States and abroad do not meet the minimum standards.
- c. OCMI's observing a pattern of negligence or non-compliance by a vessel operator have a variety of corrective action options available to them within the ACP. Immediate disenrollment from the ACP is not considered a corrective action. OCMI's should work with Coast Guard Program Managers, the classification society representatives and the vessel's owners to seek lasting solutions to a vessel's poor condition or performance. Requiring additional surveys, initiating ISM Code audits and increasing Coast Guard oversight are all viable corrective actions available to OCMI's.
- d. The goal of the ACP is for the Coast Guard, the classification society, and the vessel owner to work together to improve the overall safety and environmental compliance of U.S. vessels. Vessels that are habitually non-compliant or that have reached such a state of advanced deterioration that the frequency of system and structural failures is nearly constant should have their COI revoked until a root cause and subsequent solution to the pattern can be found.

**SECTION B: DOMESTIC INSPECTION PROGRAMS****CHAPTER 9: ALTERNATE COMPLIANCE PROGRAM**

- e. The ISM Code provides an avenue to address not only the correction of materiel deficiencies at the current inspection, but the creation and maintenance of a management system whereby the company and crew must work to prevent problems before they occur. The old "fix on failure" approach to safety is unacceptable performance for any U.S. certificated vessel. Owners that continually wait for the inspectors, surveyors or port State officials to detect problems before taking corrective action have an ineffective SMS and should be evaluated for revocation of their COI.

---

**2. Voluntary Disenrollment**

The vessel owner may request disenrollment from the ACP during the anniversary window period of the COI issue date. The owner should submit an Application for Inspection of U.S. Vessel, CG-3752 to the cognizant OCMI that indicates the request to disenroll the vessel from the ACP. The OCMI should take appropriate action to coordinate disenrollment with the ACS. The vessel owner may re-enroll in the ACP at any time following a voluntary disenrollment, but not before the first anniversary. Re-enrollment examinations should be scheduled so as not to interrupt certificate harmonization.

---

**3. SIP Enrollment or Re-enrollment in ACP**

Vessels that are disenrolled from the ACP at the owner's request may not request to enroll in the SIP or renewal in the ACP until the next anniversary date of the COI's issue. If re-enrolled with the same classification society, the U.S. supplement applicable during the original term of enrollment will remain applicable. Vessels re-enrolling in the ACP with a different classification society must meet the current U.S. supplement for that ACS. Vessels that are disenrolled from the ACP by the Coast Guard for cause may not request to enroll in the SIP or to re-enroll in the ACP for a period of five years.

---

**4. Disenrollment Inspection**

Vessel operators should submit an Application for Inspection to the OCMI specifically requesting disenrollment. When possible, vessel operators are encouraged but not required to cite the reasons for voluntary disenrollment. A Coast Guard marine inspector will attend vessels disenrolling from the ACP and inspect for certification as if the vessel was not enrolled in ACP. An invitation will be extended to the ACP Classification Society Surveyor to attend.

**SECTION B: DOMESTIC INSPECTION PROGRAMS****CHAPTER 9: ALTERNATE COMPLIANCE PROGRAM**

Upon disenrollment, the OCMI must ensure that all MISLE inspection dates are restored and that the Program Manager is promptly notified. The vessel will then become subject to inspection and examination intervals as required by applicable provisions of Coast Guard regulations, publications, and directives. Upon disenrollment, the cognizant OCMI should note in the inspection summary which U.S. supplement was used and retain a copy of that version in the vessel's file for future reference, (see H.5 of this Chapter). Additionally, the OCMI should forward a memo to Commandant (CG-CVC) announcing the disenrollment and return to traditional inspection status. Commandant (CG-CVC) will officially disenroll the vessel and notify the vessel owner by letter. The memo should include the vessel operator's application for disenrollment.

---

**5. Standards to be Used After Disenrollment**

During any period that the vessel is subject to Coast Guard inspection following disenrollment, it will be inspected to the same standards as it was under the ACP, i.e., class rules, international conventions, and the ACS U.S. supplement. However, repairs, modifications, conversions and equipment renewals will comply with the applicable CFR and Coast Guard policies. The Coast Guard does not issue International Load Line Certificates or provide tonnage measurement services. These services must be provided by an ACS. Upon disenrollment, MISLE entries must be made as discussed in O of this Chapter.

---

**I. CERTIFICATE OF INSPECTION****1. Classification Society's Inspection**

The ACS will conduct certain activities (surveys, tests, inspections and examinations) on a vessel and document its compliance with applicable international requirements; the inspection classification society's class rules, and the U.S. supplement.

**NOTE:** Only the flag State administration is authorized to approve extensions for certificates issued under international conventions. In the case where the ACS requests an extension to a convention certificate, the request must be forwarded to Commandant (CG-CVC) for approval.

**2. Coast Guard Inspection and Authority**

The Coast Guard's examinations will consist of those activities that have not been delegated to the ACS under the ACP (e.g., witnessing drills and assessing crew proficiency in handling shipboard emergencies).

**SECTION B: DOMESTIC INSPECTION PROGRAMS****CHAPTER 9: ALTERNATE COMPLIANCE PROGRAM**

- a. USCG administrative review. The cognizant OCMI will conduct an administrative review of the reports of activities performed by the ACS, and then follow-up this review with a vessel examination. The administrative review of reports and international certificates will determine if vessel equipment, components, and systems were examined at appropriate intervals using proper procedures.
- b. U.S. Coast Guard authority. The Coast Guard remains the final authority for the issuance or revocation of a COI. The ACP classification society may not endorse or issue the COI. The ACS surveyor must notify the local OCMI if conditions exist that require revocation of the COI.

---

**J. COAST GUARD RESPONSIBILITIES**

---

**1. Cognizant OCMI**

General responsibilities of the cognizant OCMI under the ACP are to--

- a. Make recommendations to Commandant (CG-CVC) for vessel enrollment;
- b. Arrange for completion of the required hand-over survey upon application for enrollment into the ACP;
- c. Ensure that equivalent levels of safety are maintained on enrolled vessels as compared to vessels that undergo traditional Coast Guard inspections;
- d. Issue COIs to enrolled vessels;
- e. Conduct prescribed oversight examinations on enrolled vessels using Commandant (CG-CVC) risk assessments;
- f. Take necessary control action of substandard ACP vessels;
- g. Make recommendations to the LORACS for oversight attendance by the Traveling Inspectors staff or the LORACS;
- h. Investigate marine casualties;
- i. Upon notification of potential or conformed ISM Code/SMS major non-conformities by an ACS, the OCMI must notify the LORACS and Commandant (CG-CVC);
- j. Notify the LORACS of any surveyor training or qualification deficiencies; and
- k. Assist Commandant (CG-CVC) and LORACS with ACS Regional and Port Office quality audits as requested.



**SECTION B: DOMESTIC INSPECTION PROGRAMS****CHAPTER 9: ALTERNATE COMPLIANCE PROGRAM****2. ACP Officer**

ACP officers must have the qualifications and experience necessary to accurately review reports of activities submitted by the ACS and be able to determine whether or not an enrolled vessel is in substantial compliance with applicable laws, international conventions, and classification society rules. ACP officers must be familiar with the applicable classification society rules, U.S. supplements, and international regulations applicable to enrolled vessels. The ACP officer should maintain (either hard copy or electronically) copies of all of the U.S. supplements (current and historical) for appropriate ACSs. The ACP officer should be well versed in the oversight program and be designated in writing by the OCMI.

**3. Program Manager**

The Program Manager, Commandant (CG-CVC), is responsible for overall administration and management of the ACP. Commandant (CG-CVC) will ensure that an appropriate number of staff members are adequately trained in auditing techniques and ACS processes in order to properly conduct ACS quality audits. Commandant (CG-CVC) will--

- a. Review each ACS's process instructions, survey procedures, and checklists;
- b. Coordinate with Commandant (CG-ENG) in reviewing and approving changes to the classification society's rules. SOLAS, MARPOL, other international conventions, and the ACP MOAs to ensure that proper changes are made to the U.S. supplements.
- c. Enroll new vessels into the ACP and maintain the ACP Vessel Group in MISLE; and
- d. Participate in the quality system of each ACS and attend internal and external audits of that system.

**NOTE:** Commandant (CG-ENG) has the primary responsibility for evaluating and approving the standards contained in a classification society's U.S. supplement.

**4. LORACS**

Beyond providing coordination between the ACSs and the Coast Guard, the LORACS has the primary responsibility for observing ACS quality audits, reviewing approximately 10 percent of the ACS ACP survey records, and tracking corrective action initiated during Coast Guard program oversight. The LORACS is also responsible for the overall coordination of the ACS oversight program, including assessing enrolled ACP vessel performance. Each vessel will be scored using a risk-based model. The LORACS will complete a semiannual risk assessment of enrolled vessels and disseminate the results to OCMI and the MSC via Commandant (CG-CVC). This risk assessment will enable OCMI and the MSC to identify program vessels requiring additional oversight and help focus local resources based upon risk. Upon notification by an OCMI or classification society of potential or confirmed ISM

**SECTION B: DOMESTIC INSPECTION PROGRAMS****CHAPTER 9: ALTERNATE COMPLIANCE PROGRAM**

Code/SMS violations, the LORACS must review the vessel's complete history and coordinate with the SMS issuer to determine the necessity of additional oversight, including an external audit. Upon notification by an OCMI of Vessel/Facility Inspection Requirements, CG-835s being issued, the LORACS will notify the ACS to ensure that those Vessel/Facility Inspection Requirements, CG-835s are reflected in the ACS's database records.

---

**5. Traveling Inspection Staff, Commandant (CG-5P-TI)**

Commandant (CG-5P-TI) should assist the OCMI and LORACS with ACP oversight activities as needed. Commandant (CG-5P-TI), in addition to conducting vessel oversight visits, should also assess ACS surveyor and Coast Guard marine inspector performance within the guidelines of the applicable ACP policy. Commandant (CG-5P-TI) should share observations and recommendations with Commandant (CG-CVC) via the LORACS. Commandant (CG-5P-TI) should conduct oversight of targeted vessels derived from the semiannual risk assessment prepared by the LORACS, as resources permit. Additionally, as resources permit, Commandant (CG-5P-TI) should assist Commandant (CG-CVC) and LORACS with ACS Regional and Port Office quality audits when requested.

---

**6. The Marine Safety Center (MSC)**

As noted in K.10 of this Chapter, the MSC performs ACP plan review and tonnage and loadline oversight. The MSC may conduct plan review oversight for all new construction, modifications (including major conversions), and vessel re-flags. The MSC is the point of contact for all plan related queries and issues. The ACS should submit a comprehensive list of plans to the MSC as part of the initial new construction or reflag enrollment to allow the MSC to select plans for oversight and better communicate with the involved parties (see MTN 04-03, series).

---

---

**K. ACP OVERSIGHT**

Coast Guard ACP oversight is intended to ensure that enrolled vessels are consistently designed, built, operated, and maintained to a level of safety that is equivalent to vessels certified under the Coast Guard's traditional inspection program.

---

**SECTION B: DOMESTIC INSPECTION PROGRAMS****CHAPTER 9: ALTERNATE COMPLIANCE PROGRAM****1. The Annual Examination**

Every ACP vessel must have an annual examination conducted by the Coast Guard to coincide with COI or reinspection dates. The annual examination must not normally duplicate those items checked by the classification society unless there are "clear grounds" to expand the examination. Annual examinations provide the OCMI with first-hand assessments of the inspection items delegated to the ACS and ensure that these items conform to applicable requirements.

An annual examination closely resembles the scope of a PSC annual examination. A key aspect of an annual examination is to verify that the classification society is meeting its obligations under the ACP rather than traditional materiel inspection. An annual examination will be documented in and follow the general procedures and scope outlined by the appropriate ACP vessel examination books. It should be of similar scope of a foreign vessel examination and include, but is not limited to general procedures and scope outlined by the appropriate ACP vessel examination books. ACP vessels' annual examination should be of similar scope of a foreign vessel examination and include, but is not limited to--

- a. Examination of the vessel's certificates, crew licenses and documents;
- b. General examination (i.e., "walk-through") of the vessel;
- c. Examination and testing of specific equipment, conducting operational tests, and emergency drills to ensure the crew's proficiency at carrying out critical tasks;
- d. A review of vessel security and verify the vessel's security plan; and
- e. Verification of the SMS, particularly lifesaving, firefighting, and navigation maintenance records. Crew competency should be briefly validated during the walk-through and emergency drills against documented SMS requirements. Prior documented non-conformities should be evaluated for proper resolution during all annual oversight examinations.

**NOTE:** "Clear grounds" means evidence that the vessel, its equipment, or its crew do not comply substantially to the requirements of the relevant conventions, rules, and U.S. supplement, or that the master or crew members are not familiar with essential shipboard procedures relating to vessel safety or pollution prevention.

**2. Suggested Preparation**

The OCMI should review the ACP classification society's vessel records to ensure that all required surveys are current prior to issuing or endorsing the COI at the annual examination. These records are available online. Links to the appropriate Web sites are available at the Coast Guard ACP Web site. If the record review reveals items that require clarification, the ACP officer must work closely with the local ACS surveyor to identify the current status of

**SECTION B: DOMESTIC INSPECTION PROGRAMS****CHAPTER 9: ALTERNATE COMPLIANCE PROGRAM**

surveys and to ensure that outstanding class recommendations or conditions of class are properly addressed. It may also be valuable to review international PSC data before boarding a vessel.

Below are some useful real-time Web-based resources. Contact the LORACS for access/passwords to classification society databases. For other Websites, contact the individual Web coordinators for access/passwords (where required). Information accessed through the resources listed below may be sensitive or proprietary and should be used for official Coast Guard business only. Inspectors should make printouts of any record that may be helpful during the inspection. The vessels often do not have easy Web access to provide additional copies.

<b>Classification Society Information</b>	<b>HTML</b>
(ABS) Safenet	<a href="http://www.eagle.org">www.eagle.org</a>
(LR) Class Direct Line	<a href="http://www.lr.org">www.lr.org</a>
(GL) Fleet On Line	<a href="http://www.gl-group.com">www.gl-group.com</a>
(DNV) DNV Exchange	<a href="http://www.dnv.com">www.dnv.com</a>
<b>Overseas Detention Information</b>	<b>HTML</b>
Paris MOU on Port State Control	<a href="http://www.parismou.org">www.parismou.org</a>
Tokyo MOU on Port State Control	<a href="http://www.tokyo-mou.org">www.tokyo-mou.org</a>
Equasis	<a href="http://www.equasis.org">www.equasis.org</a>

---

### 3. Periodic Oversight Re-examinations

The Coast Guard may conduct an examination in between annual examinations to ensure that a vessel and its crew have remained in compliance with appropriate U.S. laws and applicable international conventions. For passenger vessels, these examinations are done quarterly and are mandatory unless otherwise directed by Commandant due to operational tempo.

---

### 4. Periodic Oversight Re-examination Targeting

For all other vessel types, the ACP risk assessment prepared by the LORACS will suggest the necessity of periodic oversight re-examinations using a risk-based process. The LORACS will provide a semiannual vessel risk assessment to Commandant (CG-CVC) for Coast Guard-wide release. OCMI's may modify ACP oversight based upon the assessment in consideration of local operational tempo and resource availability.

---

**CHAPTER 9: ALTERNATE COMPLIANCE PROGRAM****5. Periodic Oversight Re-examination Scope**

The periodic oversight re-examination should normally consist of a review of the vessel's certificates, crew licenses and documents, and a general examination conducted by walking through the vessel with an emphasis on examination of items which have been the subject of any recent control actions. Inspectors are also directed to briefly examine the SMS to assure the vessel is following its SMS and non-conformities have been reported to the company, and are either resolved or in the process of resolution. Although intended to be similar to a PSC annual examination, a re-examination may be expanded as necessary if clear grounds exist to indicate that a vessel is not in compliance with applicable classification society rules, the applicable U.S. supplement or international conventions.

**6. Periodic Oversight Reexamination Scheduling**

As a courtesy, the local OCMI, upon receipt of an Advanced Notice of Arrival in a U.S. port, should notify the vessel owner or operator as soon as possible if the OCMI has selected a vessel for a periodic oversight re-examination. The same courtesy should be attempted for vessels visiting foreign ports but nothing should prevent a marine inspector in either situation from conducting a re-examination if the vessel's location is convenient. Typically, OCMI's should not require long distance travel or travel to foreign ports to conduct periodic oversight re-examinations but should capitalize upon opportunities when already in such locations.

**7. Vessel in Drydock, at Dock, or UWILD Oversight Examinations**

The OCMI should perform oversight examinations as resources permit and in consideration of the current risk assessment. Oversight may be tailored to the level that is appropriate to convince the OCMI that the provisions of the ACP are met. Historically, this has been done with roughly 10 percent of general oversight. The OCMI may request assistance from the LORACS, Traveling Inspectors Staff Commandant (CG-5P-TI) or Commandant (CG-CVC) as necessary. The OCMI may make recommendations to the LORACS regarding which ACP vessels should be considered for visits by the LORACS or Traveling Inspectors staff. The oversight examination is to--

- a. Verify compliance with the ACP Memorandum of Agreement;
- b. Ensure that ACP vessels are held to safety levels that are equivalent to those vessels undergoing the traditional Coast Guard inspection; and
- c. Ensure ACS surveyors have been adequately trained to conduct surveys on behalf of the Coast Guard.

Participation in the UWILD program for ACP vessels is approved only by Commandant (CG-CVC-1) and must otherwise follow the policy outlined in NVIC 01-89 (<http://www.uscg.mil/hq/cg5/nvic/1980s.asp#1989>).

## SECTION B: DOMESTIC INSPECTION PROGRAMS

## CHAPTER 9: ALTERNATE COMPLIANCE PROGRAM

**8. New Construction and Major Modifications**

- a. A minimum of 10 percent of each new construction or major modification project surveys that occur in an OCMI's zone will be subject to direct Coast Guard oversight. Oversight must be increased to at least 40 percent for passenger vessels. The OCMI must--
  - (1) Determine the scope of the oversight;
  - (2) Check the primary lifesaving equipment that must be approved by the Coast Guard (refer to 46 CFR Subchapter W and the U.S. supplement if applicable); and
  - (3) Meet with the ACS's Surveyor-in-Charge and the vessel's owner to develop a mutually acceptable oversight plan at the start of each project. No specific format is required but the oversight plan must be sufficiently detailed to meet oversight goals and avoid miscommunication.
- b. New construction and major conversion projects can be aided by an Oversight Plan developed and agreed to by all interested parties. A plan can be a useful tool to reduce confusion regarding responsibilities and expectations among the OCMI, the classification society, and the builder. The plan is an ideal vehicle to establish desired procedures for unique situations such as novel design determinations and potential waivers or exemptions. It can also be used to target certain systems for heightened oversight (including plan review). See G.1, above, for additional information.
- c. General oversight and focus. The amount of information required for review by the OCMI should be based on several factors including the type of vessel under construction, prior experience with the builder, the vessel's owner and operator, and OCMI's own "comfort level" with the various parties involved in the project. The OCMI should perform oversight on about 10 percent of the hull and vital machinery items surveyed by the ACS during new construction and about 50 percent of lifesaving equipment, firefighting equipment and pollution prevention equipment. Cruise ship construction and major modification oversight should receive higher levels of oversight up to 50 percent of hull, vital machinery, structural fire protection, fire detection and extinguishing systems, and lifesaving.
- d. Recommended areas of focus. The following areas are recommended as areas of focus:
  - (1) Status of applicable plan review and equipment approval.
  - (2) Status of procedures that require qualification to an established standard (e.g., weld procedures and welder qualifications, NDT test procedures, and technician qualifications).

**SECTION B: DOMESTIC INSPECTION PROGRAMS****CHAPTER 9: ALTERNATE COMPLIANCE PROGRAM**

- (3) Approval status of applicable material or equipment.
  - (4) Number and identities of the ACS's surveyors on the job site at any given time.
  - (5) Particular equipment, components, or systems scheduled for survey, test, inspection or examination at any given time.
  - (6) Which equipment, components, or systems have successfully passed final classification society inspection and test.
  - (7) Whether the project is on schedule with regard to delivery date.
  - (8) Status of items under appeal by the vessel's owner.
  - (9) Status of any items that may be left outstanding when the initial COI is issued.
- e. Minimum areas of focus. At a minimum, the cognizant OCMI should include a review of the ACS's acceptance of critical vessel systems (refer to the ACS's U.S. supplement) such as--
- (1) Lifesaving (primary lifesaving must be CG approved);
  - (2) Firefighting/fire detection/ structural fire protection;
  - (3) Cargo transfer;
  - (4) Pollution prevention;
  - (5) Steering and propulsion; and
  - (6) Hull structure.

---

**9. Damage Surveys**

The OCMI may take the classification society's repair recommendations into account. However, the OCMI retains final authority to review and approve temporary repair proposals in cases in which damage to the vessel involves or is likely to result in a pollution incident or pose a hazard to the safety of a U.S. navigable waterway. Generally, OCMI's should accept the classification society's approval of recommended permanent repairs provided the vessel no longer poses an immediate pollution or navigation safety threat.

---

**SECTION B: DOMESTIC INSPECTION PROGRAMS****CHAPTER 9: ALTERNATE COMPLIANCE PROGRAM****10. Plan Review and Associated Oversight**

In support of the oversight process, each ACS will, as a minimum, provide the MSC with all of the information required in MSC Technical Note 04-03 (series). The classification society should review and approve vessel plans based upon applicable classification society rules, the international conventions/codes, and the U.S. supplement. Plans that are approved on behalf of the Coast Guard should be stamped by the classification society as "Approved on behalf of the U.S. Coast Guard per the ACP" or similar language to distinguish the specific program under which the plan approval was authorized. The Coast Guard may retain plan review authority as deemed appropriate by the MSC. The MSC may request certain plans for oversight review.

Vessel systems requiring extensive equivalency determinations will also be subject to plan review oversight by the Coast Guard. Plan review oversight is not always done in real time as it is meant to be a process verification vs. quality review. If significant items arise from plan review oversight, then scope and detail of oversight may be increased. If there are specific systems or areas of concern to an OCMI, then targeted plan review oversight may be requested.

---

**11. Reduced Manning**

The OCMI may consider reduced manning requests in accordance with the requirements and procedures of 46 CFR Part 62.50 and the MSM Volume III, Marine Industry Personnel, COMDTINST M16000.8B (Series) based on the classification society's approval of any automation system(s). Annual examinations should include a cursory/random test of several automated systems using the vessels' procedures and a cursory review of the engine room maintenance records. The tests should oversee the classification society's survey performance, obtain a general impression of the systems' condition, and assure that the manning levels remain adequate based upon the crew's proficiency.

---

**L. ACP AUTHORIZED CLASSIFICATION SOCIETY QUALITY AUDITS**

Coast Guard representatives with Quality Systems Auditor training will observe 10 percent of the internal and external audits conducted at the ACS's corporate or local offices. Quality audits include a Vessel Records Audit that may be performed, at the request of an OCMI, by the Program Manager or the LORACS to follow up on serious conditions of class or noteworthy non-conformities observed during vessel oversight examinations. In general, the distribution of oversight will be as follows:

- a. Oversight of Class Headquarters Audits will be conducted by Commandant (CG-CVC) at least biennially.



**SECTION B: DOMESTIC INSPECTION PROGRAMS****CHAPTER 9: ALTERNATE COMPLIANCE PROGRAM**

- b. Oversight of Class Regional Offices will be conducted by the Commandant (CG-CVC) and/or Commandant (CG-5P-TI) staff at least annually.
  - c. Oversight of Class Port Office audits will be conducted by the local OCMI as requested by Commandant (CG-CVC). Where the Port and Region offices are co-located, the OCMI representative should attend the regional office audit in the company of the Commandant (CG-CVC) or Commandant (CG-5P-TI) representative. All Port Offices in the United States must be audited annually either by an internal or external auditor.
  - d. Classification society audits at any level may be attended by the LORACS in lieu of other Coast Guard attendees.
- 

**1. Audit Benefits**

The audits ensure that--

- a. Quality standards and procedures are in place and being observed;
  - b. Quality records are available and up-to-date; and
  - c. Corrective actions are taken on non-conformities.
- 

**2. Specific Items to Consider During Audits**

- a. Specific items of interest to the Coast Guard during the audits are--
  - (1) Surveyor training and qualification process is being documented and surveyors have up-to-date qualifications for any surveys they carry out on behalf of the Coast Guard (including the ACPs);
  - (2) Port and regional offices are implementing their monitoring program of surveyors;
  - (3) Vessel files and records are accessible to the Coast Guard and contain current and correct information on U.S. vessels;
  - (4) Internal audits are being carried out;
  - (5) Notifications to the Coast Guard, when required, are being made at all levels of the organization; and
  - (6) The instructions to surveyors include relevant information relating to the ACP and other U.S. Coast Guard authorizations.

**SECTION B: DOMESTIC INSPECTION PROGRAMS****CHAPTER 9: ALTERNATE COMPLIANCE PROGRAM**

- b. The Coast Guard has agreed to act as observers at internal audits conducted by the quality department of the classification society and external audits conducted either by an independent Quality Registrar who certifies the quality system of the classification society or audits conducted by the Quality Directorate of the International Association of Classification Societies (IACS). A separate Coast Guard audit will not be done. Advanced notice of audits will be provided to Commandant (CG-CVC) (through the LORACS) who will make notifications to Commandant (CG-5P-TI) and OCMI's as appropriate.

---

### 3. Audit Reports

The person observing the audit will provide a narrative summary of each audit observed to Commandant (CG-CVC) and the LORACS in a Coast Guard Memo. Although no specific format is required, the reports should include at least the following information:

- a. A copy of the audit schedule showing departments audited and the titles or jobs of the people interviewed.
- b. A copy of the audit findings.
- c. An opinion as to whether the work being done under Coast Guard authorization is in conformance with the quality system and the agreement between the ACS and the Coast Guard.
- d. Any other information that should be considered by the program manager with regard to the classification society.

**NOTE:** Information revealed during a classification society quality audit may include proprietary information protected from release to third parties by the Privacy Act of 1974. A notation should be made on the Coast Guard audit summary reports that state the following: "This report may contain information protected under the Privacy Act of 1974 and should be evaluated prior to disclosure to third parties."

---

### 4. Coast Guard's Role During Audits

All Coast Guard personnel assigned as audit observers must have completed the ISM Code lead auditor training course, either as an independent course or as part of the advanced marine inspector training course. Other training may be accepted in lieu of this requirement on a case-by-case basis by Commandant (CG-CVC). In all cases, the Coast Guard will allow the lead auditor to manage the flow of the audit. In general, the lead auditor will define the time allocated to each area and will work with the audit team to develop the questions to be asked. Coast Guard personnel are encouraged to request that the vessel records pulled for examination include some U.S. vessels. Auditors will generally offer the Coast Guard

**SECTION B: DOMESTIC INSPECTION PROGRAMS****CHAPTER 9: ALTERNATE COMPLIANCE PROGRAM**

observer an opportunity to ask additional questions that may be of specific interest to U.S. flag vessels. Observers should be mindful of the audit schedule and, if they desire detailed information about a particular area, make arrangements to meet with the classification society separate from the audit.

---

**M. DEFICIENCIES AND REPORTING**

---

**1. Coast Guard Vessel/Facility Inspection Requirements, Form CG-835**

The OCMI may issue a Vessel/Facility Inspection Requirements, CG-835 to an ACP vessel in the same manner as a vessel inspected under the Coast Guard's traditional inspection program. However, issuing a Vessel/Facility Inspection Requirements, CG-835 should be a last resort for vessels enrolled in the ACP. Efforts must be made to have the classification society survey or attend the vessel to concur in the corrective action necessary and to generate an Outstanding Recommendation (OSR) or Condition of Class. If an OSR or Condition of Class is issued, no Vessel/Facility Inspection Requirements, CG-835 should be issued.

If a deficiency exists and no action is being taken by the attending Class Surveyor, a Vessel/Facility Inspection Requirements, CG-835 may be issued. In such a case, the LORACS should be notified and OCMI must provide copies of the Vessel/Facility Inspection Requirements, CG-835s to the ACS's local office. The LORACS will verify proper entry of the discrepancy in the ACS's database. The ACS's local office will forward the Vessel/Facility Inspection Requirements, CG-835 to the classification society's central record division for inclusion into the vessel's computer record as a "Condition of Class." Other cases when a Vessel/Facility Inspection Requirements, CG-835 may be appropriate would be when a surveyor isn't immediately available (i.e., during a periodic oversight re-examination or casualty investigation).

ACS class surveyors, with prior approval by the OCMI, may clear Vessel/Facility Inspection Requirements, CG-835 items by drawing a line through the item, endorsing it as cleared, and forwarding a copy to the local OCMI for MISLE updates. ACS class surveyors may extend or modify outstanding Vessel/Facility Inspection Requirements, CG-835s with the concurrence of the issuing OCMI. ACS class surveyors should also make an appropriate notation on the bridge record card when clearing a Vessel/Facility Inspection Requirements, CG-835.

---

**SECTION B: DOMESTIC INSPECTION PROGRAMS****CHAPTER 9: ALTERNATE COMPLIANCE PROGRAM****2. Operational Control Actions and Detentions**

When, in the opinion of the OCMI, an ACP vessel is unsafe to proceed to sea, and/or when it poses a serious threat to life, property or the marine environment, appropriate control actions must be taken. These may include suspension of the COI, COTP orders, and other operational control actions include no-sail Vessel/Facility Inspection Requirements, CG-835s for critical systems, i.e., lifesaving, firefighting, watertight integrity discrepancies. U.S. operational control actions for ACP vessels should be reported to the LORACS.

Additionally, if during a routine vessel examination, it is discovered that a vessel has been subject to a PSC detention within the past two years the particulars of the detention must be reported to the LORACS. Letters of Deviation should not normally be considered control actions for the purposes of this policy unless the vessel operator fails to adequately address the deficiency for which the deviation was issued.

---

**3. Reporting of Marine Casualties**

Masters of vessels enrolled in the ACP are required to report marine casualties to the Coast Guard in accordance with 46 CFR Part 4.

---

**N. RECORDKEEPING****1. Documentation Required for ACP**

OCMIs must document ACP examinations in the appropriate ACP Inspection Book, CG-840 which may be downloaded from <https://collab.uscg.mil/lotus/myquickr/domestic-vessel-inspections/tools>. Information recorded in this booklet should--

- a. Identify the documentation reviewed;
- b. Identify the individual(s) who conducted the examination, and the name of the surveyor attending hand-over, annual, or other ACP examinations;
- c. Briefly summarize the results of the examination;
- d. Describe the drills that were conducted and comment on the crew's performance;
- e. Describe the condition of the equipment, components and systems that were observed in operation incident to the drills;
- f. Record the status of any conditions of class;
- g. Summarize SMS compliance; and
- h. Cite any other factors relevant to supporting the finding that the vessel is in compliance with the ACP and is fit for its intended route and service.

**SECTION B: DOMESTIC INSPECTION PROGRAMS****CHAPTER 9: ALTERNATE COMPLIANCE PROGRAM****O. MISLE ENTRIES**

---

**1. MISLE Initial Hand-Over**

- a. Upon completion of a satisfactory hand-over survey, the OCMI must notify the Program Manager, Commandant (CG-CVC), to recommend that the vessel be enrolled in the ACP, preferably by signed memo via email or confirmed fax. Commandant (CG-CVC) must also be notified of an unsatisfactory hand-over survey. The OCMI must document the recommendation in the MISLE inspection results.
- b. Upon acceptance of the vessel into the ACP, Commandant (CG-CVC) must update MISLE and include the vessel in the ACP Vessel Group. Upon disenrollment, the Program Manager must delete the vessel from the ACP Vessel Group, at the same time adding a historical note for that vessel indicating that the vessel has been disenrolled from the ACP.
- c. OCMI must complete the MISLE screen field for "ACP COI" under activity subtype for an initial hand-over survey.
- d. The OCMI must make the following entry in the COI operating details:
  - (1) "This vessel has been inspected and certificated in accordance with the terms and conditions specified in the U.S. Coast Guard's Alternate Compliance Program (ACP). Date of ACP enrollment (DD MMM YYYY)."
- e. The OCMI or the Program Manager must make the following entry as a special note in MISLE:
  - (1) "This vessel has been inspected and certificated in accordance with the terms and conditions specified in the U.S. Coast Guard's Alternate Compliance Program (ACP). ABS is the ACP Classification Society. Date of ACP enrollment: DD MMM YYYY. ABS Class ID is #####. See Commandant (CG-CVC-1) letter dated DD MMM YYYY for more details."
- f. Special care should be taken to ensure that MSP vessels are not inadvertently enrolled in the ACP. While an MSP vessel is eligible to enroll, the vessel does not need to meet the U.S. supplement standards. Therefore, a vessel typically cannot comply with both the MSP and ACP standards at the same time. A vessel should not have both MSP and ACP endorsements on the COI.
- g. MISLE should be updated with sufficient information needed to issue the COI as detailed in N, above, since the bulk of the inspection records will be maintained by class societies. Minimally, this requires all international Convention Certificates and U.S. issued documents, including the International Ship Security Certificate, and Continuous Synopsis Record to be properly updated.

**SECTION B: DOMESTIC INSPECTION PROGRAMS****CHAPTER 9: ALTERNATE COMPLIANCE PROGRAM**

- h. Lifesaving equipment inspection due dates, machinery inspection intervals, and drydocking due dates need not be updated in MISLE on ACP vessels since the ACS will be tracking/surveying these items.
  - (1) Do not delete required equipment, machinery, or safety appliances from the COI; it is only required to delete dates from these COI fields. The ACS is responsible to maintain current records of ACP vessels and provide access to those records to Coast Guard inspectors.
  - (2) Access to these records may be obtained at any time by contacting the local office of the ACS or may be obtained online where that capability exists (see the table in K.1 of this Chapter). Units that experience problems with obtaining records from the classification society should contact the LORACS for assistance.
- i. An adequate narrative should document the hand-over survey which should cover relevant inspection/verification items and any specific compliance nuances unique to the vessel. Narratives should always document major nonconformities and Vessel/Facility Inspection Requirements, CG-835s if issued.

---

**2. MISLE Initial Construction**

If the vessel enrollment occurs during the construction phase, it may be necessary to use the hull number as the Vessel Identification Number (VIN) while documenting activities in MISLE. Prior to using the hull number as the primary VIN, ensure that no other VIN such as documentation number or CG number has been created. It may be necessary to communicate with the National Vessel Documentation Center to ensure they create the documentation number in the same record. This will help to avoid duplicative records.

---

**3. MISLE Post Enrollment**

- a. Any no-sail Vessel/Facility Inspection Requirements, CG-835s should be entered into MISLE as an operational control using the appropriate drop down menu.
- b. Clear deficiencies from MISLE upon notification by the ACS the vessel is in compliance.
- c. Maintain COI data as outlined in O.1.c through O.1.f above.
- d. Use the MISLE “ACP Annual Exam” drop down selection when conducting an annual oversight examination.
- e. Use the MISLE “ACP Periodic Oversight” drop down selection when conducting a periodic oversight re-examination.

**SECTION B: DOMESTIC INSPECTION PROGRAMS****CHAPTER 9: ALTERNATE COMPLIANCE PROGRAM**

- f. An adequate narrative should document annual and periodic re-examination oversight, which covers relevant inspection/verification items. Narratives should always document major-nonconformities and Vessel/Facility Inspection Requirements ,CG-835s if issued.
- 

**4. MISLE Disenrollment and Transfers of Class**

- a. OCMI's disenrolling vessels must re-enter all dates in accordance with current regulatory inspection intervals. Dates must be based on the last ACP survey dates conducted before disenrollment. Further, OCMI's must add the following phrase on the COI operating details:
- (1) "Disenrolled from the ACP on (DD/MMM/YYYY). Vessel should be inspected to the ACP standard using International Convention requirements, Class Rules, and the U.S. Supplement dated (DD/MMM/YYYY)."
- b. Vessels being disenrolled must also have a special note to expire after 10 years entered in MISLE briefly explaining the purpose of disenrollment, (i.e., voluntary/involuntary). If disenrollment is involuntary, the narrative should explain in greater detail the specifics leading to the disenrollment. An example follows:
- (1) "(Voluntarily/Involuntarily) disenrolled from the ACP on DD MMM YYYY. Vessel should be inspected to the ACP standard using International Convention requirements, Class Rules, and the U.S. Supplement dated DD MMM YYYY. See Commandant (CG-CVC-1) letter dated DD MMM YYYY for more details."
- c. Vessels transferring class should also have a special note detailing the change to expire after 10 years as follows:
- (1) "Transferred class on DD/MMMM/YYYY. Vessel should be inspected to the ACP standard using International Convention requirements, (gaining classification society) Class Rules, and the U.S. Supplement dated DD MMM YYYY. See Commandant (CG-CVC-1) letter dated DD MMM YYYY for more details."

**SECTION B: DOMESTIC INSPECTION PROGRAMS****CHAPTER 10: THE STREAMLINED INSPECTION PROGRAM (SIP)****A. INTRODUCTION TO THE STREAMLINED INSPECTION PROGRAM**

---

**1. Introduction**

The Streamlined Inspection Program (SIP) is an alternative to traditional Coast Guard inspections and was developed in response to the Maritime Regulatory Reform Initiative. The Initiative challenged the Coast Guard to re-evaluate its regulatory programs and to develop alternatives that would ensure the same level of safety. The information contained in this chapter is intended to provide an overview of the program. The guiding policy document is NVIC 2-99 (Series). NVIC 2-99 and its enclosures, including Inspection Criteria References (ICRs) by the applicable Title 46 subchapter, (Inspection Schedule and Verification (ISV) Form, Exam Checklists, Coast Guard SIP Inspection Form, etc.), are available on CG HOMEPORT (<http://homeport.uscg.mil>).

---

**2. Difference from Traditional Inspections**

The significant difference between SIP and the traditional annual inspection program is in the process of how compliance is ensured. SIP is an alternative process for ensuring compliance with the CFR, in which company personnel conduct frequent, periodic examinations of the various vessel systems, document their findings, and take the necessary corrective actions specified in the Coast Guard-approved plans when discrepancies are discovered. The Coast Guard will still conduct required inspections of the vessel(s); however, the manner of conducting the inspection will be considerably different.

---

**3. How Compliance is Assured**

SIP is not a self-inspection program. Under SIP, the Marine Inspector's primary focus is to review the implementation and management of the SIP by the company and check some critical vessel systems to verify accuracy of the records. SIP, properly implemented, ensures enrolled vessels are maintained in a continual state of regulatory compliance. This continual state of compliance is assured through the development of both the Company Action Plan (CAP) and Vessel Action Plan(s) (VAP). These plans must be approved by the OCMI. The company will develop these plans with the assistance of a Coast Guard SIP Advisor, assigned to work with the Company SIP Representative.

---

---



**SECTION B: DOMESTIC INSPECTION PROGRAMS**

**CHAPTER 10: THE STREAMLINED INSPECTION PROGRAM (SIP)**

**B. ENROLLMENT IN SIP INVOLVES A FOUR-PHASE PROCESS**

---

**1. Phase One: Application**

The company sends a request, in writing, to their cognizant OCMI to be considered for SIP enrollment.

---

**2. Phase Two: Plan Development**

After a satisfactory review of the company (e.g., review of company records in Coast Guard files, interview of inspectors, etc.), the OCMI will assign a SIP Advisor to assist the Company SIP Representative in developing the CAP and VAP.

---

**3. Phase Three: Operational Evaluation**

Once the CAP and VAP are approved, a mutually agreed upon trial period will be conducted to operationally test the effectiveness of each plan to ensure continual compliance with the regulations.

---

**4. Phase Four: Enrollment**

At the end of the trial period, and at the request of the company, the Coast Guard SIP Advisor will conduct an initial Coast Guard SIP Inspection with representatives from both the Company and the Coast Guard Travelling Inspector Staff, Commandant (CG-5P-TI) to evaluate the program. If the inspection is successful, the OCMI will endorse the vessel's COI for enrollment in SIP.

---

---

**SECTION B: DOMESTIC INSPECTION PROGRAMS****CHAPTER 10: THE STREAMLINED INSPECTION PROGRAM (SIP)****C. FIRST STEP TOWARDS ENROLLING A VESSEL IN SIP**

Regulations governing SIP are found in 46 CFR Part 8. Guidance and supporting documents including Inspection Criteria References (ICRs), SIP Forms, and sample CAPs and VAPs may be found on CG Homeport at <http://homeport.uscg.mil>. When a vessel owner decides to pursue enrollment in SIP, they must apply to the local Coast Guard OCMI. The OCMI will provide the vessel owner/operator with information on the application procedures. Policy questions should be addressed to the SIP Program Manager at the Office of Commercial Vessel Compliance, Commandant (CG-CVC-1); (202) 327-1224 or CG-CVC-1@uscg.mil. The guidance documents and example ICRs and forms should not be considered encompassing for all vessels that may be enrolled in SIP. This material is provided as examples and templates and should be modified as needed for each participating vessel. Vessel operators must create ICRs for all systems required to be inspected under applicable Federal Regulation including but not limited to the relevant sections of Titles 33, 46, and 49 CFR; and amplifying policy or regulations, such as IMO Conventions, NVICs, The Marine Safety Manual, and official Coast Guard Policy Letters. These ICRs should be reviewed periodically for currency and the affected Company and Vessel Action Plans revised as the underlying regulations or policy changes require.

---

---

**D. GOALS AND BENEFITS**

The primary goal of SIP is to have vessels operate in continual compliance with the regulations, rather than the cyclical peaking of vessel materiel condition associated with the traditional annual inspections. Benefits that have been realized by SIP companies in SIP include better management of vessel costs and an increased involvement and responsibility by vessel personnel for the safe operation of the vessel, and an increase in crew professional advancement.

---

---