

# COMINT AND COMSEC: THE TACTICS OF 1914-1918

**It was exciting, often dangerous work, and an important part of our heritage**

The names weren't coined until later, but what we now call tactical Comint and Comsec began back in 1914, at the start of World War I. The history of that war is in many ways a history of the development of our business.

Except for being less sophisticated, some things were pretty much the same as they are today—CA, TA, DF, R&D, and a rough approximation of a Service Cryptologic Agency. In other ways, the business was considerably different. Much of the intercept was from wirelines, although radio, then in its infancy, yielded valuable intelligence. So new was the idea of Comsec that its lapses, particularly on the Allied side, caused the death or capture of hundreds of thousands of men.

The business grew so rapidly that there was little time for planning. Innovation was the thing, but the innovators were not so much the staff officers at headquarters as they were the privates and corporals in the trenches.

## *The Setting*

The outbreak of hostilities in August 1914 saw the warring powers in various stages of readiness to engage in communications interception. Among the Allies, the French were the best prepared; they simply put their prewar radio intercept activity on a war footing and continued copying German traffic. Though lacking a formal intercept organization, the Austrians were more Comint-conscious than their German allies. England and Russia had made little or no preparation for intercepting tactical communications.

Field stations as we know them today didn't exist in 1914. Instead, the belligerents used their fortress radio stations as impromptu intercept sites. The Germans in particular considered interception strictly a sideline, something to be done when the fortress stations were not busy with regular military communications.

As haphazard as it was, this kind of interception yielded immense benefits before the war was a month old. On their own initiative, probably to fill some idle time, a few German operators began listening in on Russian army traffic. They must have been amazed at what they heard. The Russians, lacking wirelines, were sending their tactical messages by radio. Worse, lacking codes and cryptographers, they were transmitting in plain language. The resulting intelligence advantage allowed the outnumbered Germans to win a major victory at Tannenberg, the first great battle on the Eastern Front. The Russians lost an estimated 130,000 men—killed, missing or captured. The Russian Second Army ceased to exist; its commanding general committed suicide.

The German commander, General von Hindenburg, immediately became a national hero and was credited with having planned the Battle of Tannenberg 30 years before it occurred. The truth was, of course, that the Russians, poorly trained, poorly equipped and often poorly led, were no match for a German force armed with advance knowledge of the Russians' plans. Colonel Max Hoffman, Hindenburg's brilliant operations officer, acknowledged the value of the intercepts. "We had an ally," he said, "the enemy. We knew all the enemy's plans."

~~CONFIDENTIAL~~

A Russian Minister of War later testified that after Tannenberg "the war was lost." That is debatable, but it is clear that the abysmal lack of concern for communications security was a major factor in Russia's military defeats. Hoffman put it this way:

We were always warned by the wireless messages of the Russian staff of the positions where troops were being concentrated for any new undertaking. Only once during the whole war were we taken by surprise on the Eastern Front . . . .

### Listening In

If the early Comint war in the east was directed against radio traffic, in the west it was waged mainly against wirelines. And again the initial advantage was with the Germans, but this time it was no accident.

By the summer of 1915 the British realized that the Germans somehow had advance warning of their every move. Carefully planned attacks were met with deadly enemy fire; newly emplaced guns were shelled before they could be fired; relieving troops were met with heavy barrages. The Germans even knew which British units were going into the line and when. One Scottish battalion was welcomed by its own regimental march played on a German cornet from the other side of no-man's land.

At first spies were suspected, and a spy mania swept the British lines. Then came the realization that their telephone and telegraph communications could be intercepted. Though the Allies didn't know it at the time, the Germans had been reading their traffic for at least six months.

The device that made this possible was the so-called "Arendt apparatus," named for the then German Postal Councilor who developed it. According to Wilhelm Flicke, a German cryptologist in both world wars, the device was patterned after some captured French equipment, probably for wiretapping. The Arendt set, which may have been just an amplifier connected to a switchboard, was the heart of a widespread wireline intercept operation which the Central Powers maintained on all the fighting fronts. Until reasonably adequate Comsec measures were instituted—in 1917 in the west, never in the east—the Germans and Austrians had it within their power to copy virtually every Allied message sent in the forward areas of the battle lines.

How did they do it? Simply by taking advantage of two facts: (1) That when an alternating current is put into the ground or into a wire it radiates a certain distance, and (2) that all the armies were using alternating-current telephone and telegraph sets, often with one side of the circuit connected to ground. Even when the circuit was not grounded, there was frequently enough leakage or crosstalk from the wires to permit inductive pickup. It

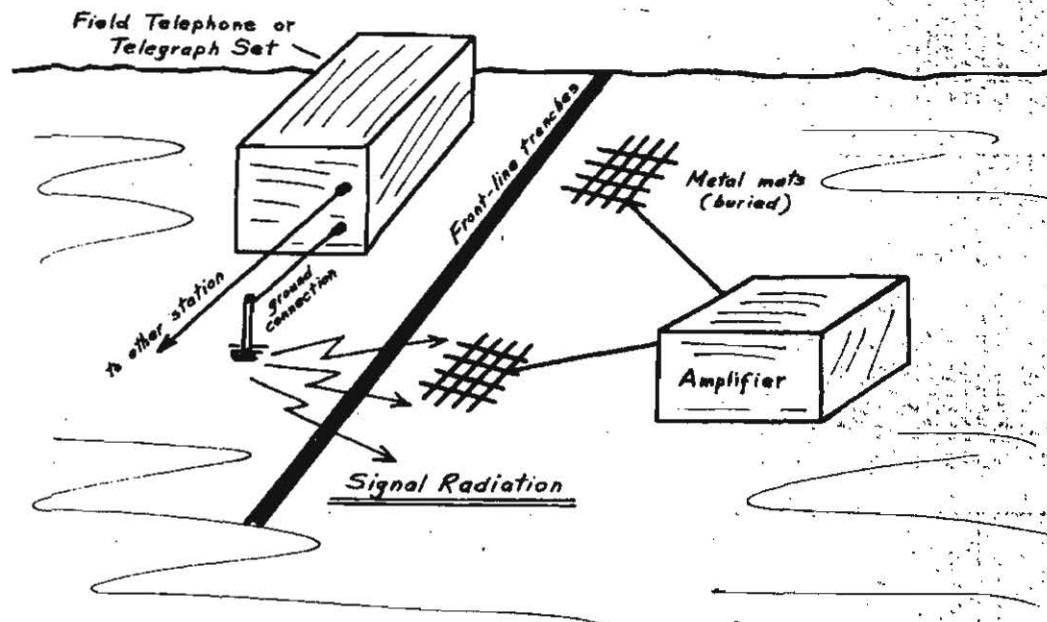

"Listening In": How It Was Done

6 ~~CONFIDENTIAL~~

~~CONFIDENTIAL~~

wasn't necessary to tap the lines: the interceptors had merely to bury metal mats or drive metal rods as near as possible to the enemy lines, run wires back to the intercept site, and reap the traffic. In wooded country, pickup wires were run along the treetops parallel to the enemy lines.

That was in August 1915. Little progress was made on the Allied side until the following February, when the French introduced a vacuum tube amplifier, which greatly increased the distance, up to four miles, over which ground signals could be intercepted. It wasn't long until the Allies caught up with the Central Powers and had listening stations operating every 10 km along the front.

Most of the listening stations were literally holes in the ground, and working conditions were anything but plush. The U.S. Army's Chief Signal Officer described them this way: "... the operators' living quarters consisted of a dugout the size of a packing box, together with a smelly pool arising from the subsoil, and rodents a foot long to complete their discomfort. In these quarters four men slept, ate, and worked."

Intercept operators handled both telephone and telegraph traffic, so they had to be both linguists and

Morse operators. They also doubled as traffic analysts, determining the movement of enemy forces by changes in voices, accents, Morse operating characteristics and signal strengths.

#### *Radio*

When equipped with antennas and detectors, the listening stations became radio intercept stations. The volume of intercept varied directly with the mobility of the armies; during the years of static trench warfare (1915-1917), radio was used mainly for emergency communication and air-to-ground work. Because radio equipment in those days operated on low frequencies (below 3 MHz), transmitting and receiving antennas had to be large. In exposed areas they made excellent targets, and this tended to limit the use of radio.

Hiding an intercept antenna was also a problem. But when it could be done (in woods, for example), and when armies were on the move, the intercept stations heard signals in such confused abundance as to make today's intercept operator want to hang up his earphones. The



**A. U.S. Army Signal Corps receiver typical of those used during World War I. This is the AR-4 (SCR-54), a crystal detector set used for receiving fire control instructions from airplanes. Its frequency range was 545 to 1200 kHz.**

(Courtesy of Antique Wireless Association)

~~CONFIDENTIAL~~ 7

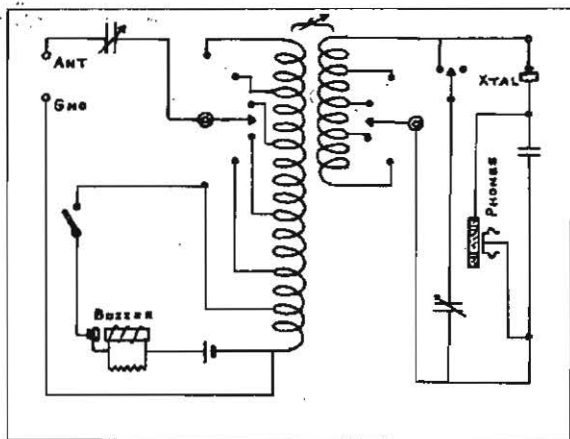
~~CONFIDENTIAL~~

Schematic diagram of the SCR-54 receiver. (From an instruction manual dated October 24, 1918.)

worst noisemakers were the spark transmitters, both friendly and enemy, that filled the air with their growling signals. Because spark was essentially a pulse transmission, it covered lots of spectrum, a problem not helped much by the poor selectivity of most of the receivers then in use.

Added to the spark signals was noise from earth telephone and telegraph sets, power buzzers (a form of earth telegraphy), electric generators, and, of course, static. For the intercept operator, it was anything but quiet on the Western Front.

Improved equipment and better Comsec led to greatly increased use of radio during the later part of the war. In January 1917, for example, there were about 125 German radio stations on the Western Front; by August there were almost 700.

#### DF

In direction finding, the British and French got the jump on the Central Powers. Early in the war, British naval intelligence used DF to track German warships, and both the British and French armies operated DF stations in France. The French also developed a truck-mounted DF set for field use. The German army wasn't equipped with DF until late 1915, the Russians not until mid-1916.

U.S. Army Signal Corps figures show how important DF was. During the last 10 months of the war 20 American DF stations took almost 180,000 bearings. On May 27, 1918, three NCO's, working 8 hours each, set a record by taking 670 bearings in 24 hours, or an average of one every two minutes. And it was all done manually, even to the turning of the loop antenna.

8 ~~CONFIDENTIAL~~

DF became so highly developed that when the Americans captured the St. Mihiel salient in September 1918 they learned that their DF had not only located every German station in the salient but had done so with a maximum error of only 500 yards.

#### *The Direct Approach—Wiretapping*

Tapping the enemy's wires, though dangerous, was tried at one time or another by all the belligerents. The French were particularly daring. A corporal, bored at having nothing to do because jamming prevented his copying enemy signals, crawled across to the German lines with about a mile of fine wire. Finding a telephone central, he attached his wire to a trunk line and crawled back to his own lines. For the next four hours the station copied every word sent over the enemy circuit, getting information of considerable value.

Then there was the American intercept operator who followed a raiding party into the German trenches and put a tap on an enemy ground connection. He then listened in on German traffic for several days before his wire was discovered and cut.

#### *Secret Systems (Or Were They?)*

Considering the air of mystery that surrounded radio at the time, it isn't surprising that rumors of secret radio communications flourished during World War I. One of the earliest rumors had it that German spies were using secret signals to guide Zeppelins on their bombing raids over England. A thorough investigation by British naval intelligence failed to discover any such signals.

The hardest of the "secret signals" rumors concerned the Germans' alleged use of high-frequency radio (3 or 4 MHz) to communicate with their forward units without being detected by Allied intercept stations. The truth is hard to pin down. On the plus side is the fact that in 1918 the U.S. Army Signal Corps developed a portable Morse radio "which would furnish a more nearly uninterrupted and secret means of communication with troops in advance positions." Its frequency was about 4 MHz, or the same as that of the rumored German set. If we could do it, so probably could the Germans.

On the other hand, the biographer of Major Edwin Armstrong, whose superheterodyne receiver resulted partly from a search for the suspected German signals, says flatly that the signals "proved to be nonexistent."

A variation of the story had German submarines using shortwave (again about 4 MHz) to escape radio interception. That rumor also remains unresolved.



*Organization*

In the beginning there was little formal structure to the intercept and security business. But as these activities became more and more important, both sides found it necessary to organize them in some way.

All countries used signal troops to operate and maintain their intercept, DF and security services. The British army's listening and security service, consisting of 20 to 30 sets, was originally administered by a GHQ officer called Inspector of Listening Sets. In March 1917 that position was abolished and the service was transferred to corps headquarters where it collaborated with the intelligence staffs at army headquarters. Radio interception, called "Intelligence wireless," was nominally administered by the Signal Service but in practice it took its orders from a special branch of the Intelligence staff at General Headquarters.

The Americans set up a Radio Section of the Signal Corps from which men were assigned to intercept, DF and Comsec duties with the various armies of the American Expeditionary Forces. Wirelines connected the field stations to the Radio Intelligence Section (G-2) of the General Staff. Established July 28, 1917, the radio intelligence section was headed by Captain (later Lt. Colonel) Frank Moorman of the Coast Artillery Corps. Of the beginnings of the Section, Moorman later said:

The personnel of the Radio Intelligence Section was limited to its chief. There were no records. There was no material on which to work. There was a general idea that the section was to read German code and cipher

messages, but how this was to be done, and the details of getting the messages were not specified.

From that uncertain start there developed a well-organized, efficient intercept service, the equal of any in the world.\* Its value was demonstrated in many ways, most dramatically in the saving of lives. A letter of commendation put it this way: ". . . the information furnished by the Radio Section has probably saved more men than are engaged in this service."

That was undoubtedly true, for at the end of the war the Army Radio Section in France numbered only 12 officers and 402 enlisted men. Those 414 men ran the entire Comint/Comsec operations of the American Expeditionary Forces during World War I. The Radio Intelligence Section (the NSA of its day) was staffed by a total of 78 men during the 15 months of its existence.

*(Continued next issue)*

\*The first American radio intercept station began operating December 8, 1917, at the headquarters of the French Second Army. It soon became so proficient that its host's intelligence staff requested copies of the intercept.

[redacted] of the Director's Staff, has more than an academic interest in radio history. He enlivens the subject by collecting and restoring antique radios. Receivers from his collection of more than 30 sets have been seen on local TV shows, and his article on restoring antique radios was published in *Popular Electronics*.

(b) (3) - P.L. 86-36