

C:\USERS\NATHAN\PROBOX (S20 DESIGN)\DOCUMENTS\SALMON_ID\DESIGN\ACTIVE DRAWINGS\EAST CHANNEL DESIGN.DWG

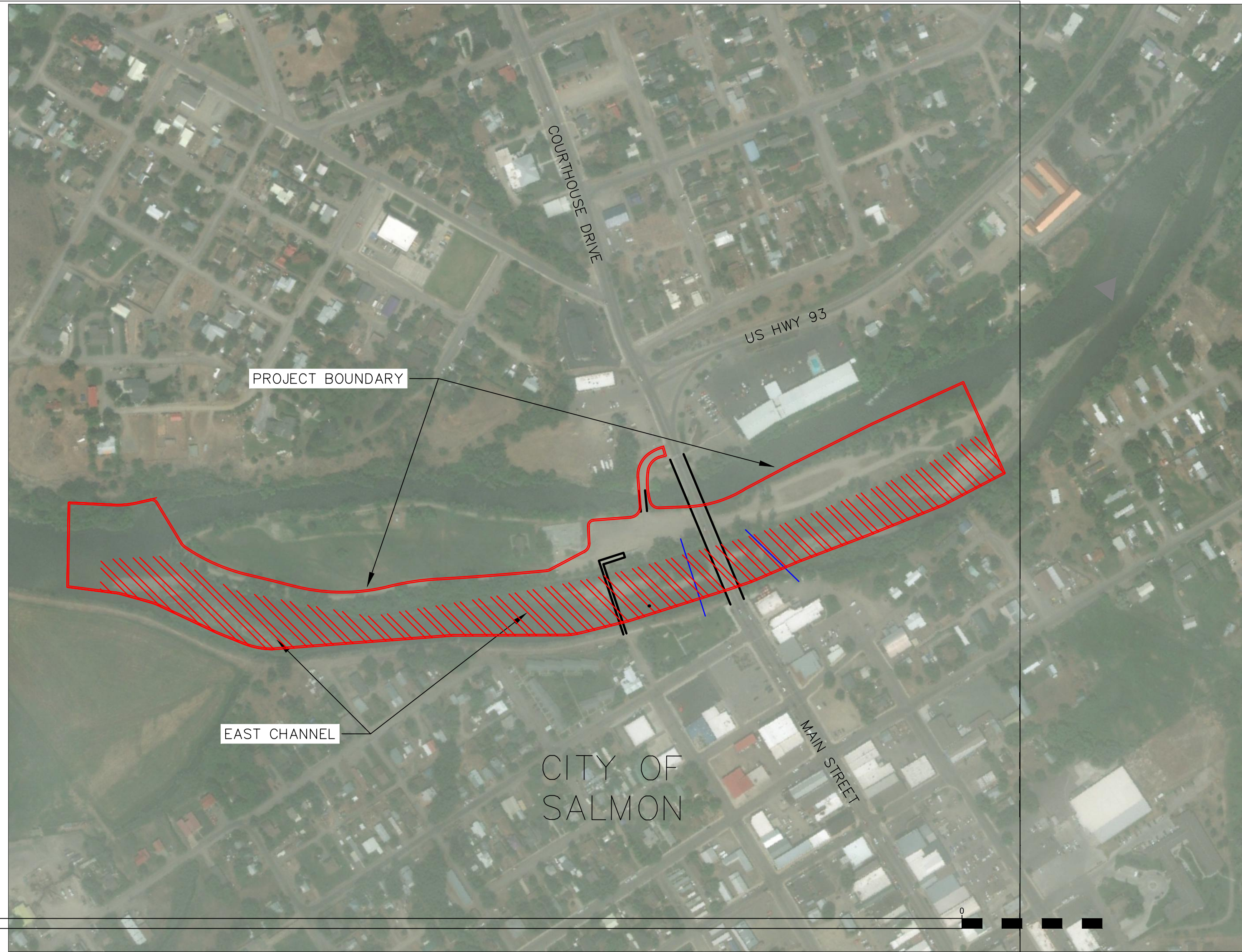

LOCATION MAP: STATION AND RIVER
NTS

T T TI
T T TI
T T TI

T I L T I L

T I L T I T I L
T I L T I T I L

T I L
T I L
T I L



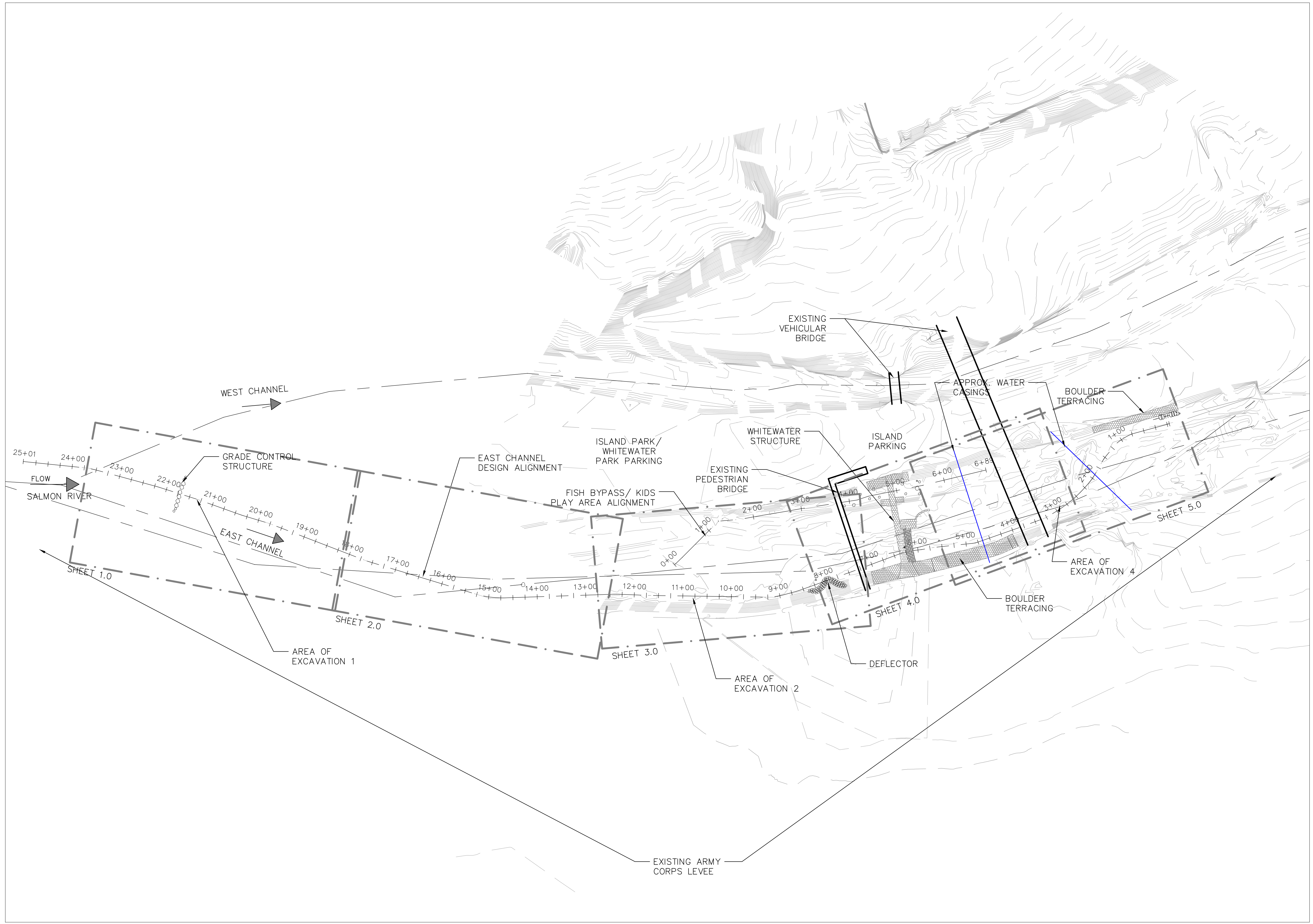

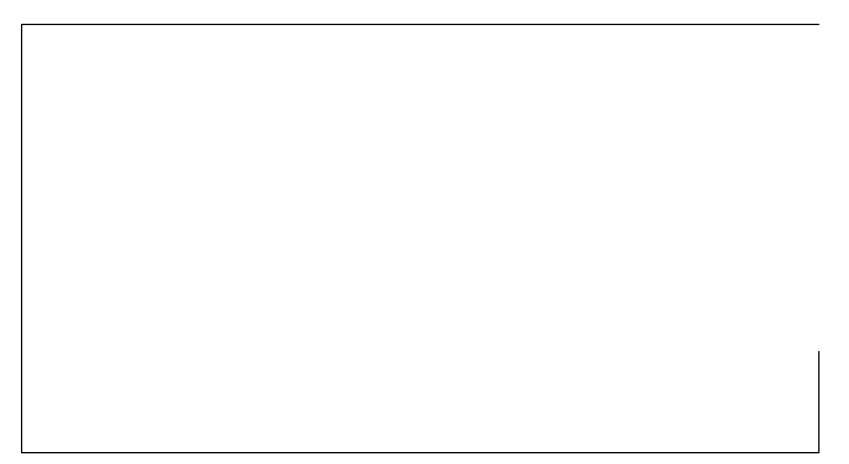
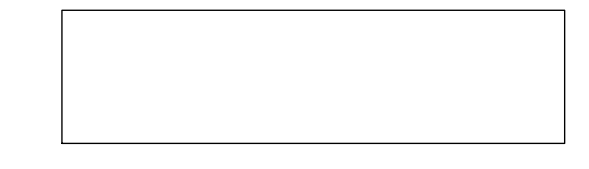
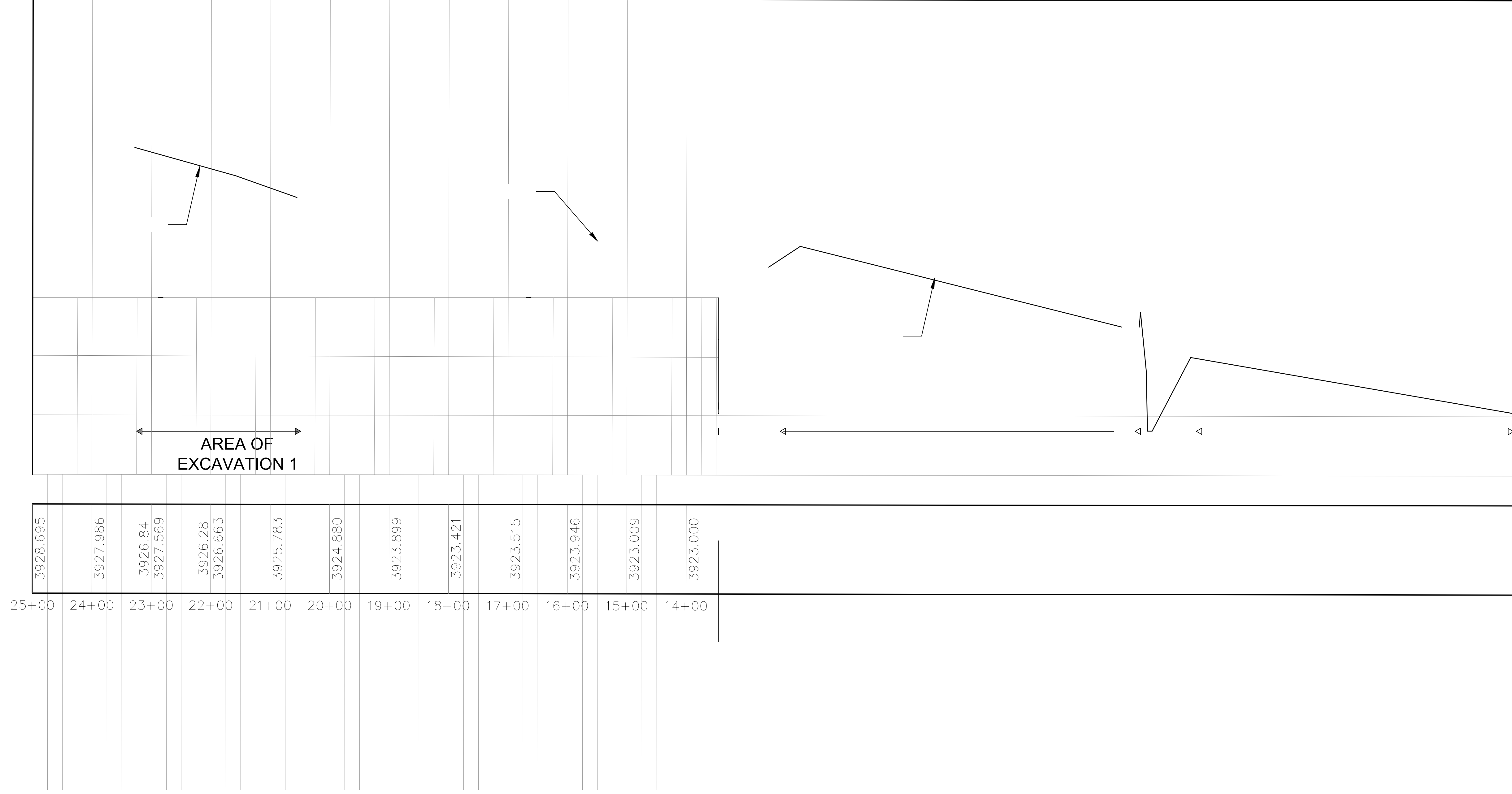

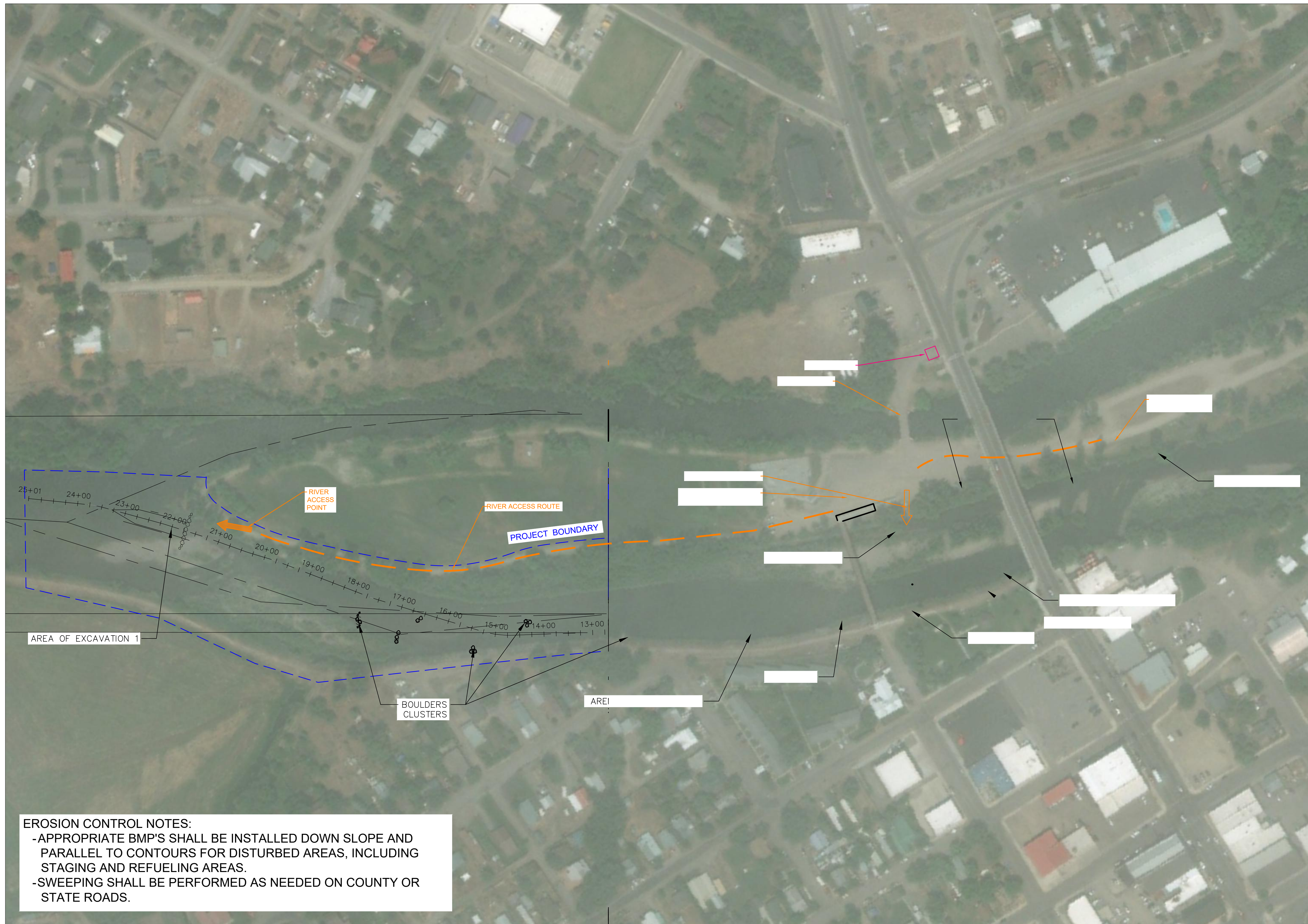

EROSION CONTROL NOTES:
- APPROPRIATE BMP'S SHALL BE INSTALLED DOWN SLOPE AND PARALLEL TO CONTOURS FOR DISTURBED AREAS, INCLUDING STAGING AND REFUELING AREAS.
- SWEEPING SHALL BE PERFORMED AS NEEDED ON COUNTY OR STATE ROADS.



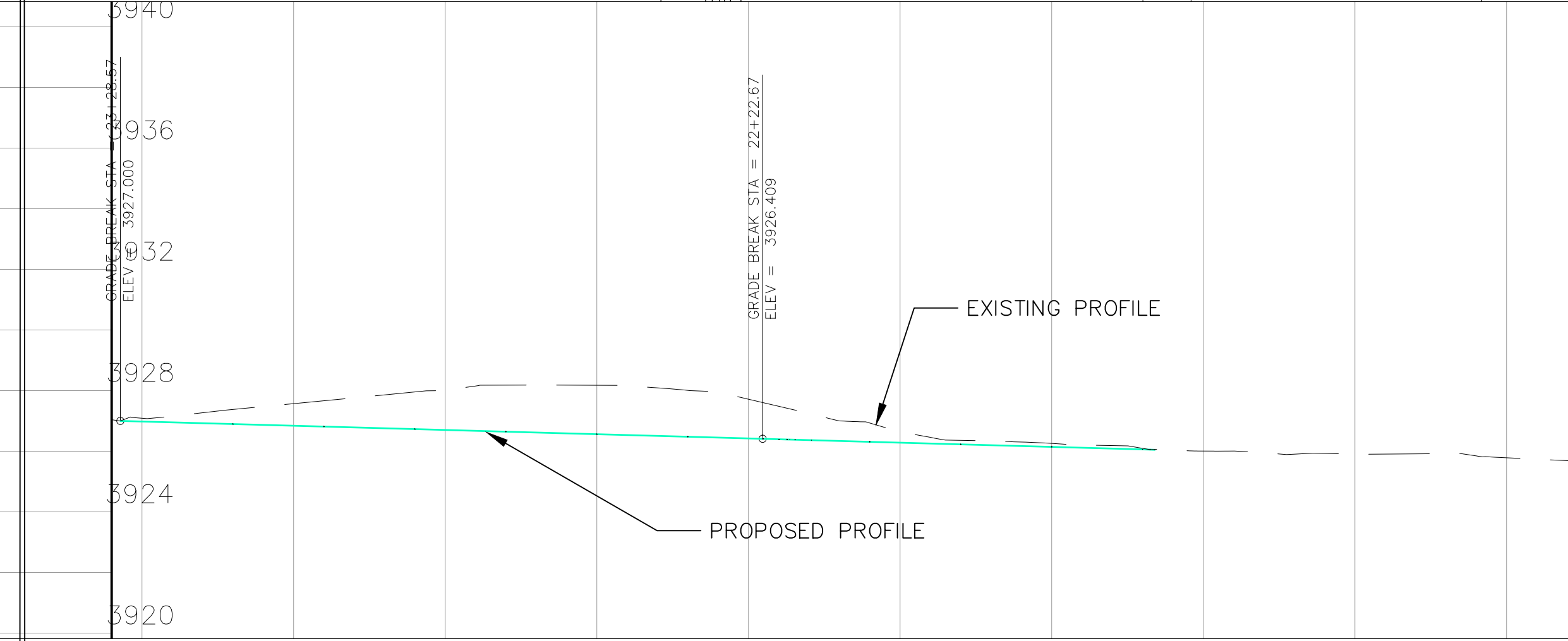
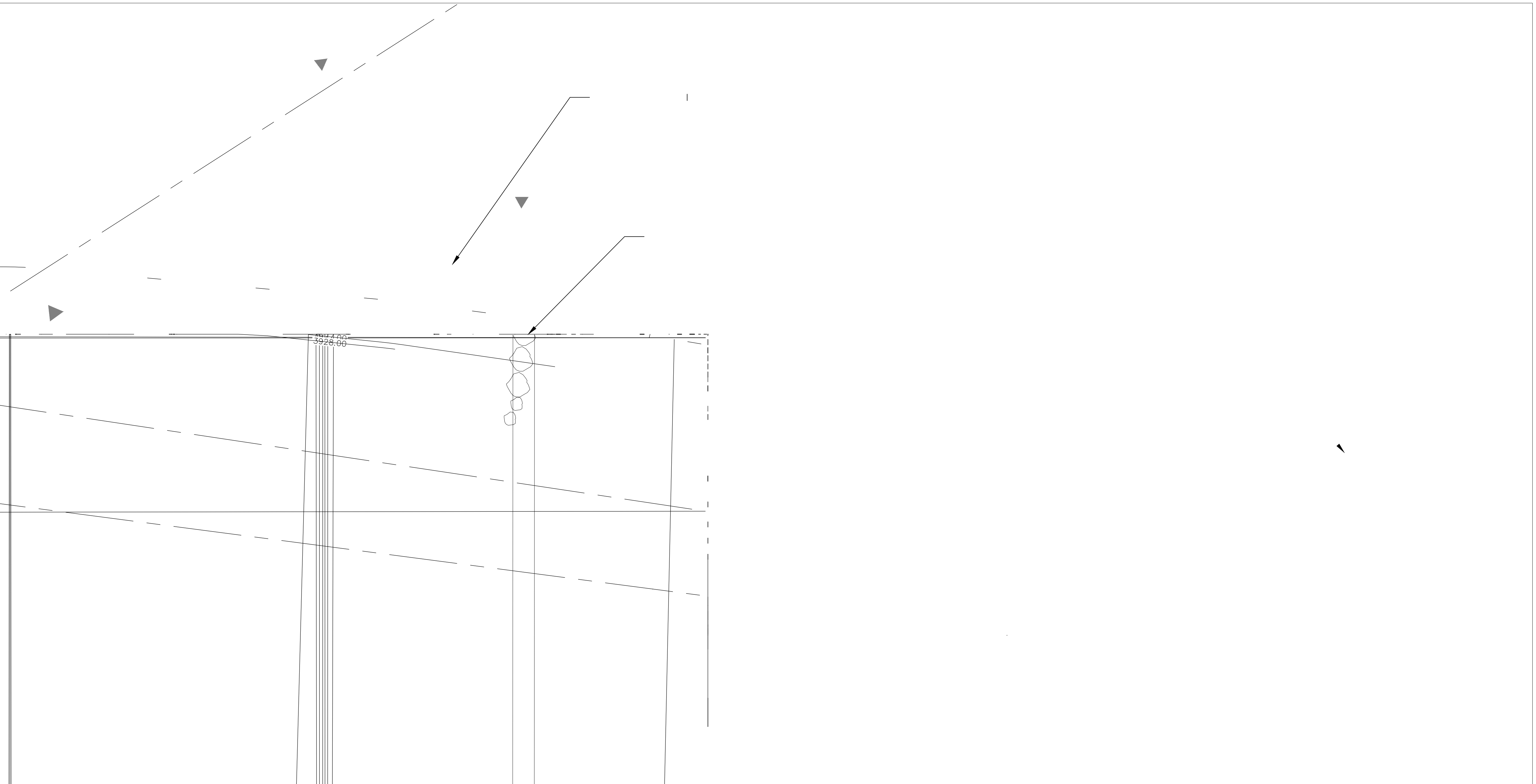

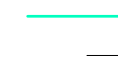
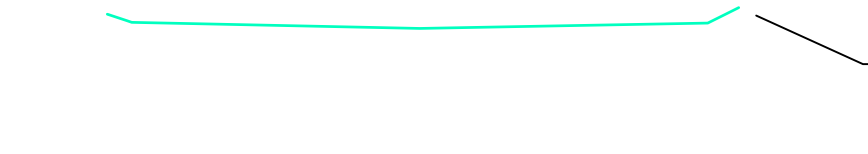
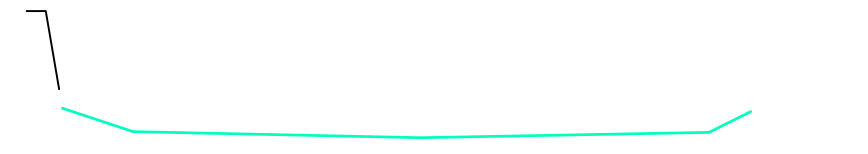
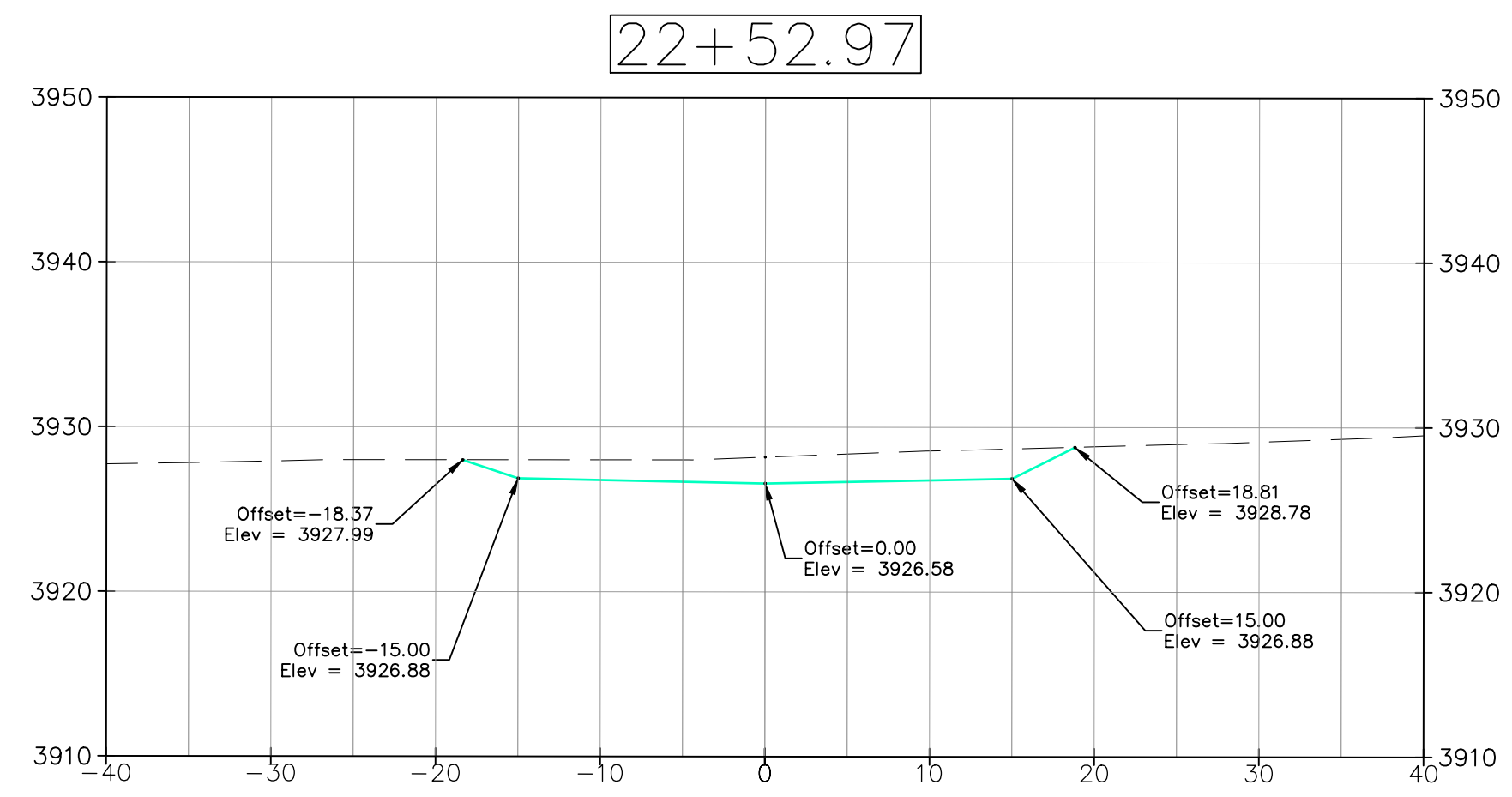
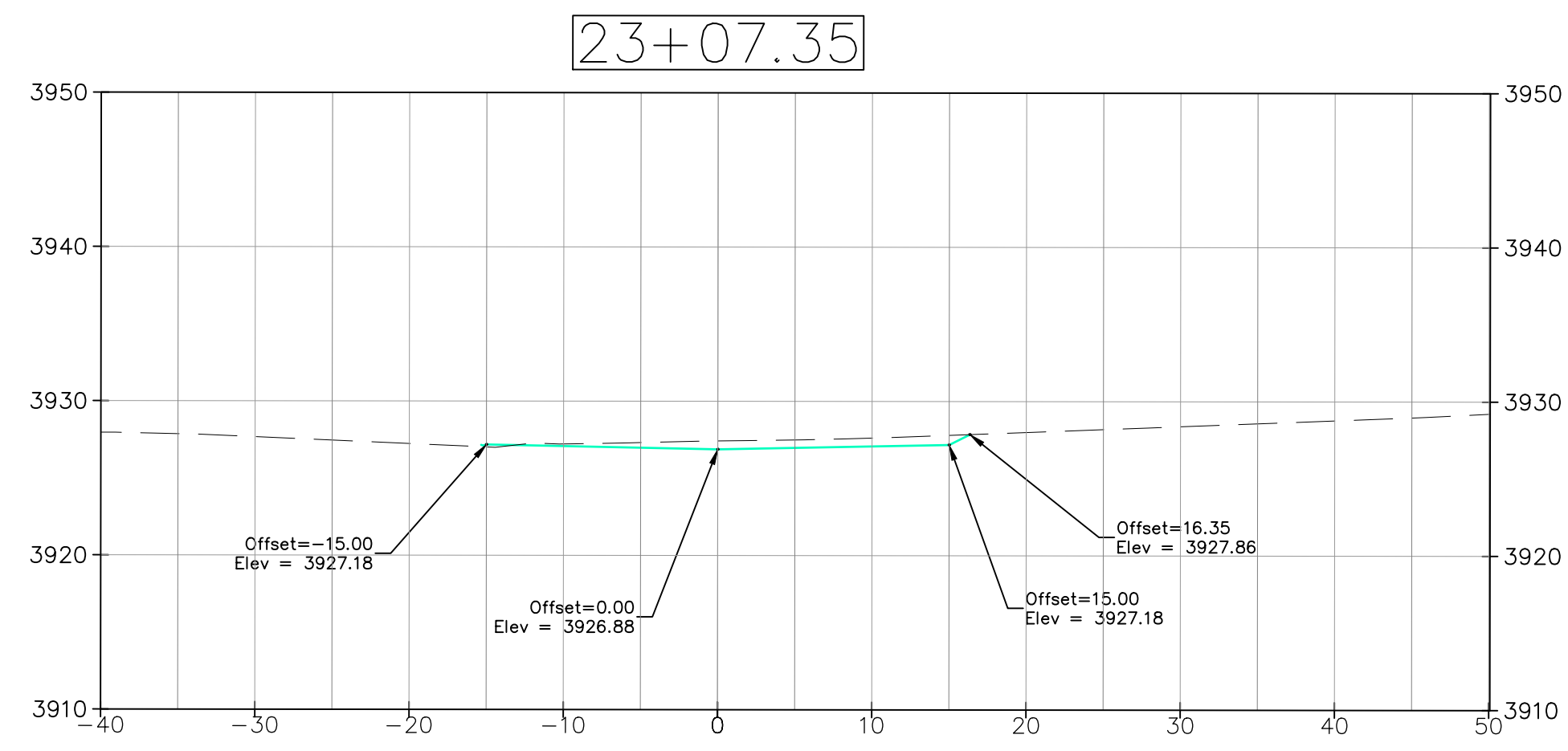

C:\USERS\NATHAN\DROPBOX (S20 DESIGN)\DOCUMENTS\SALMON_ID\DESIGN\ACTIVE DRAWINGS\EAST CHANNEL DESIGN.DWG

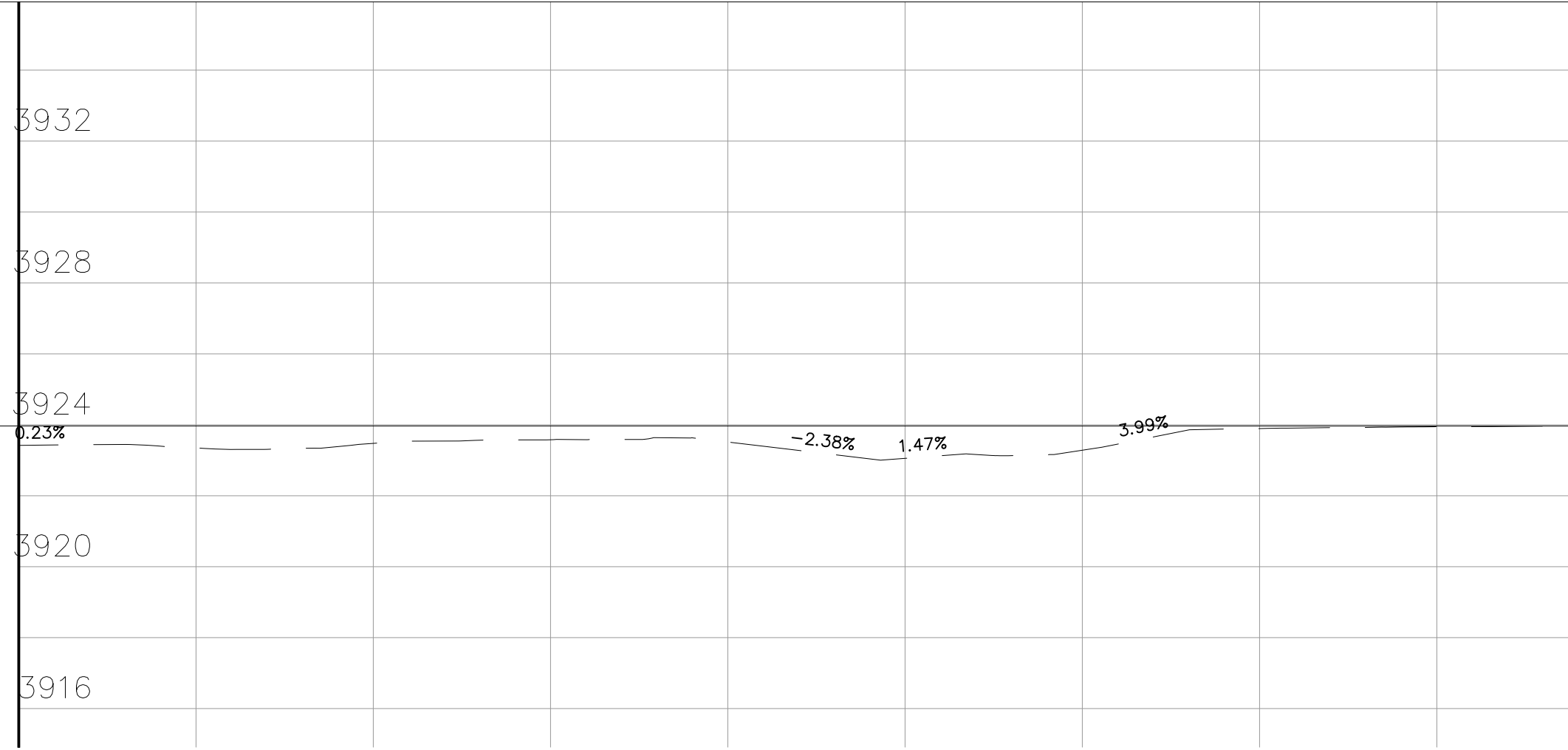
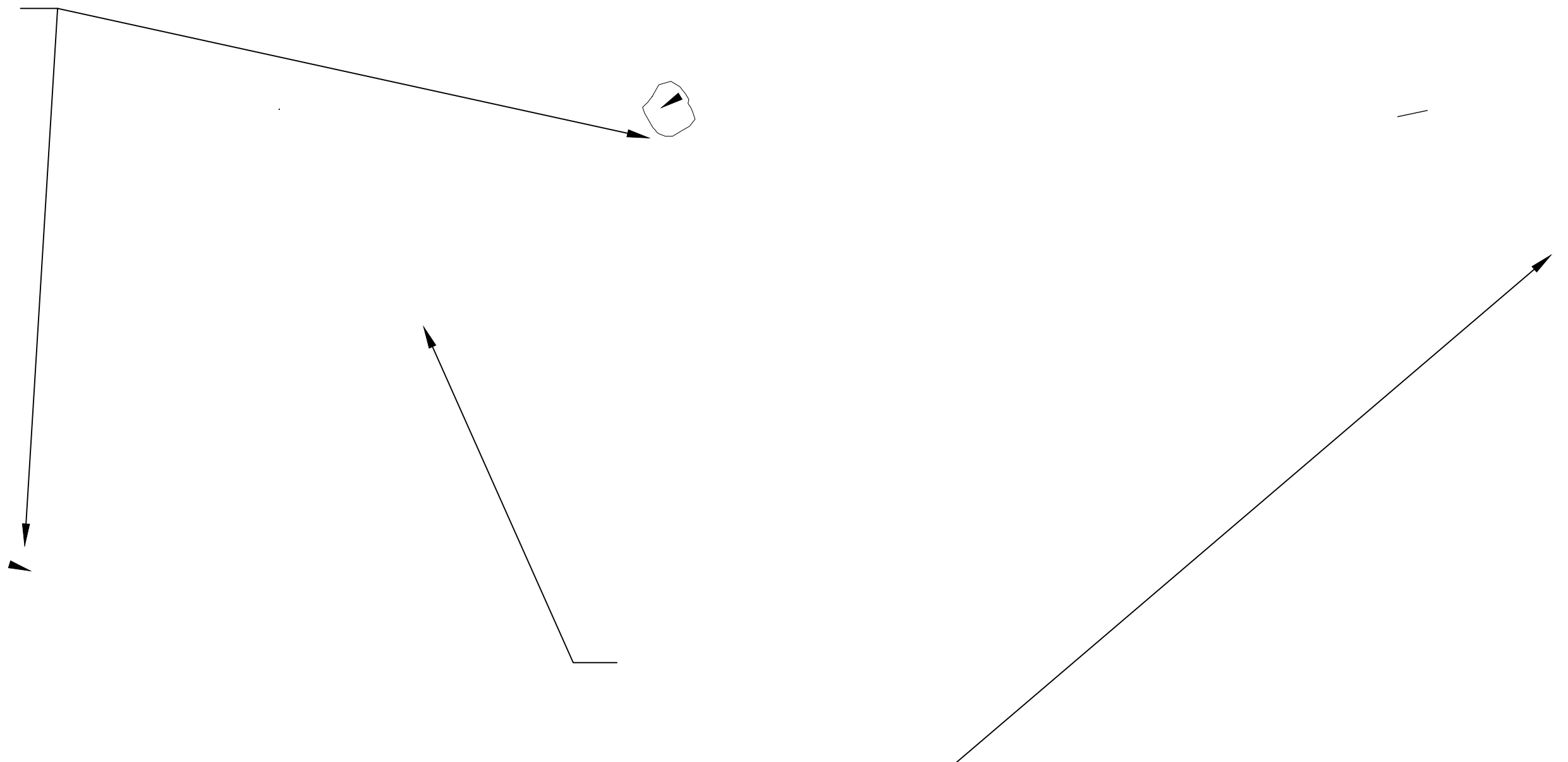
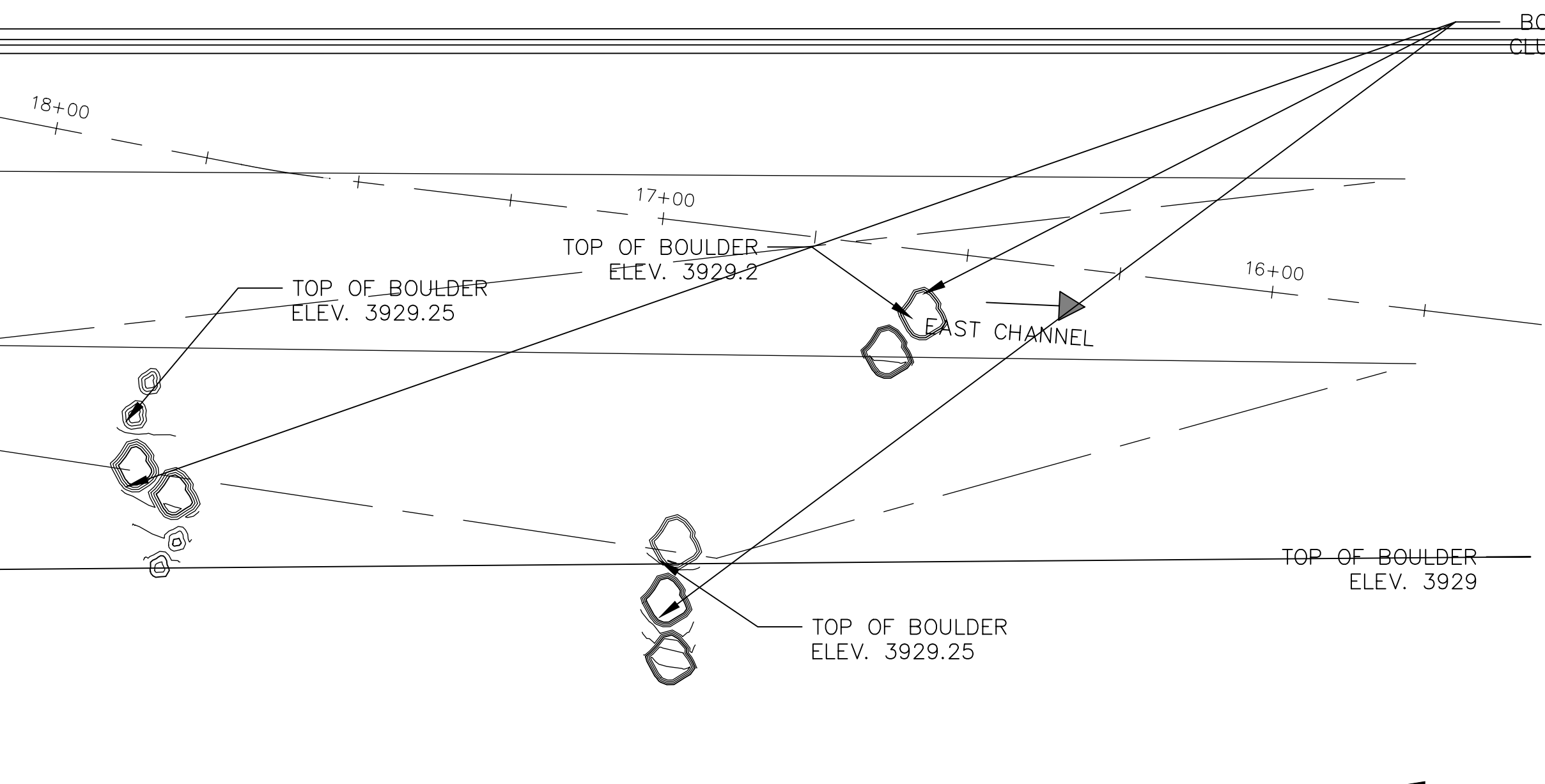

C:\USERS\NATHAN\DROPBOX (S20 DESIGN)\DOCUMENTS\SALMON_ID\DESIGN\ACTIVE DRAWINGS\EAST CHANNEL DESIGN.DWG

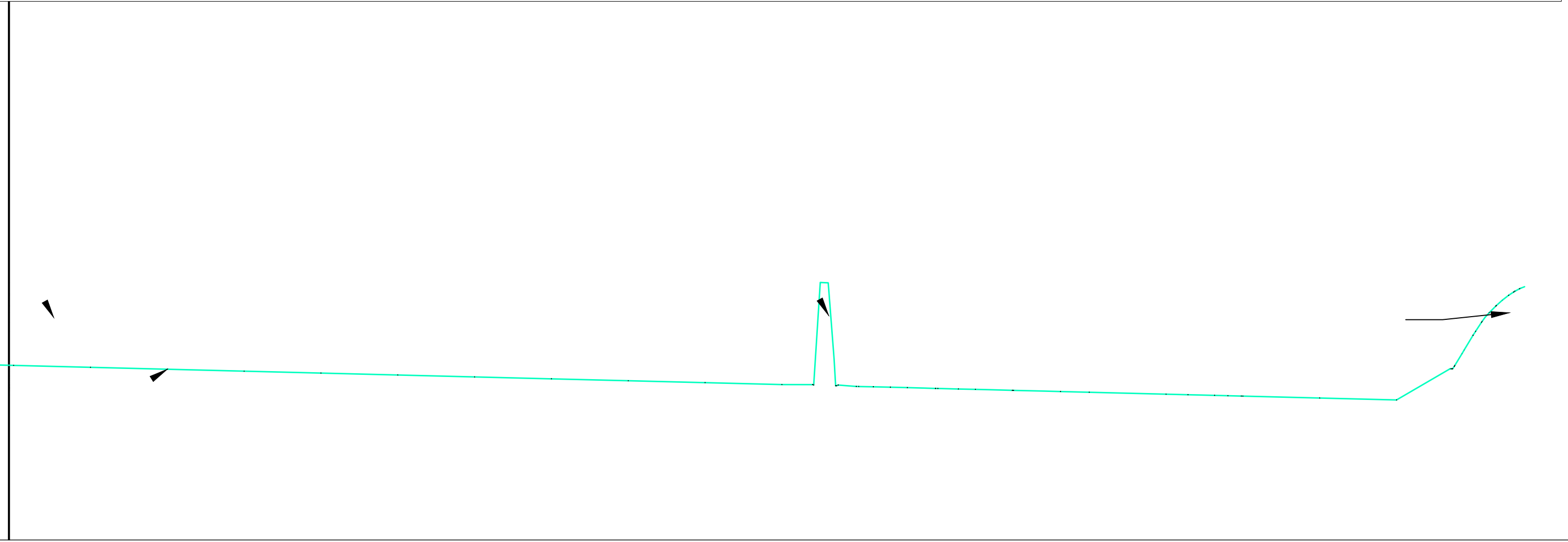
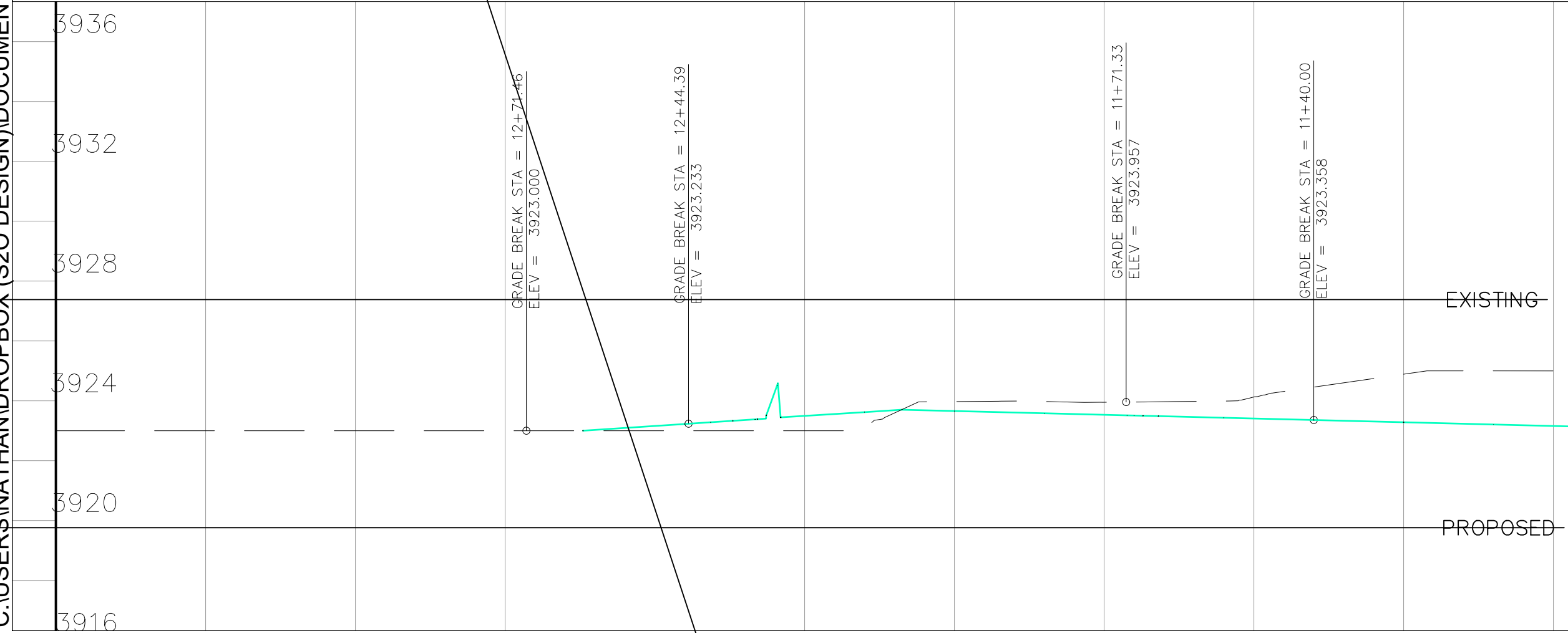
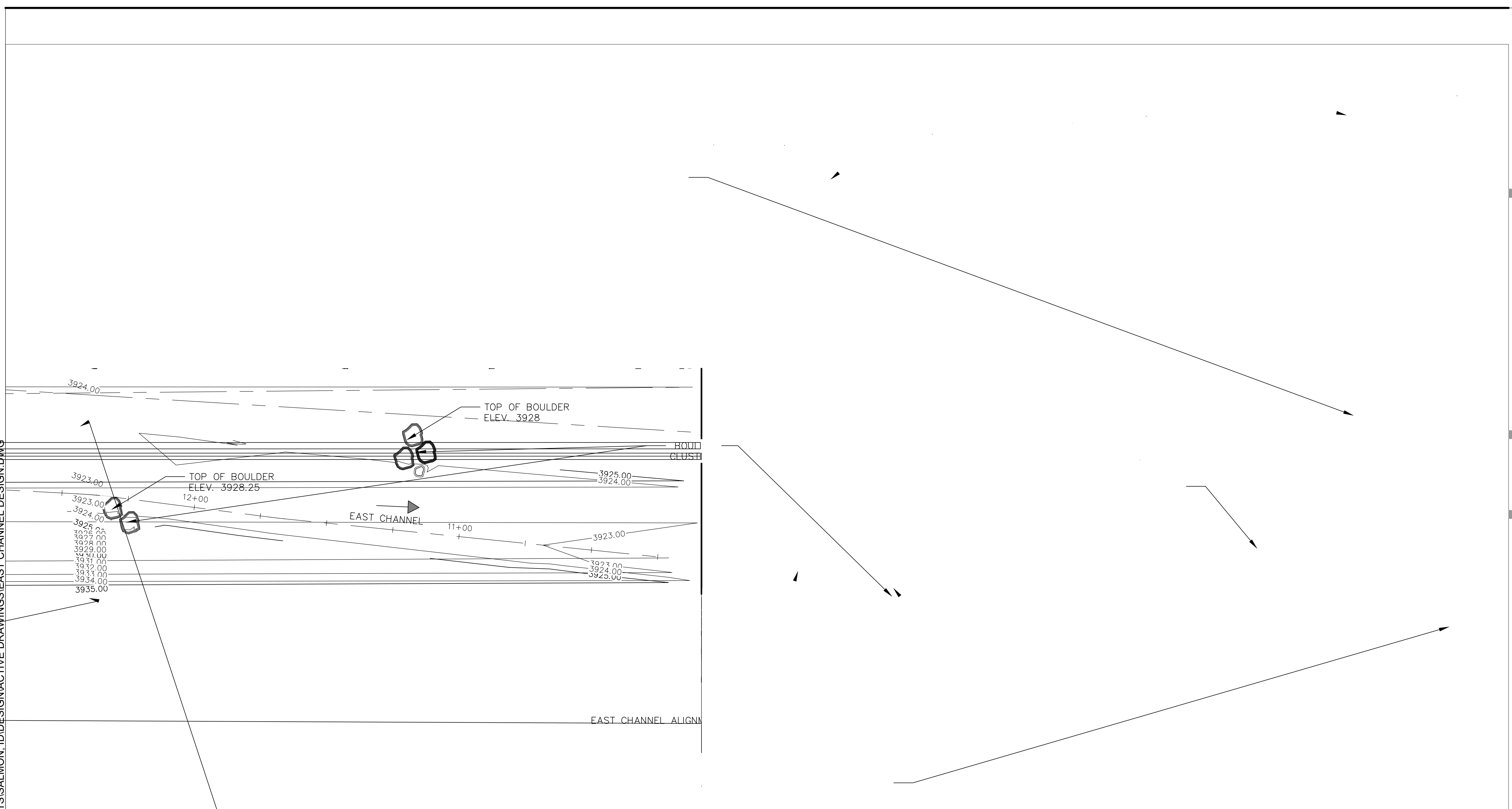

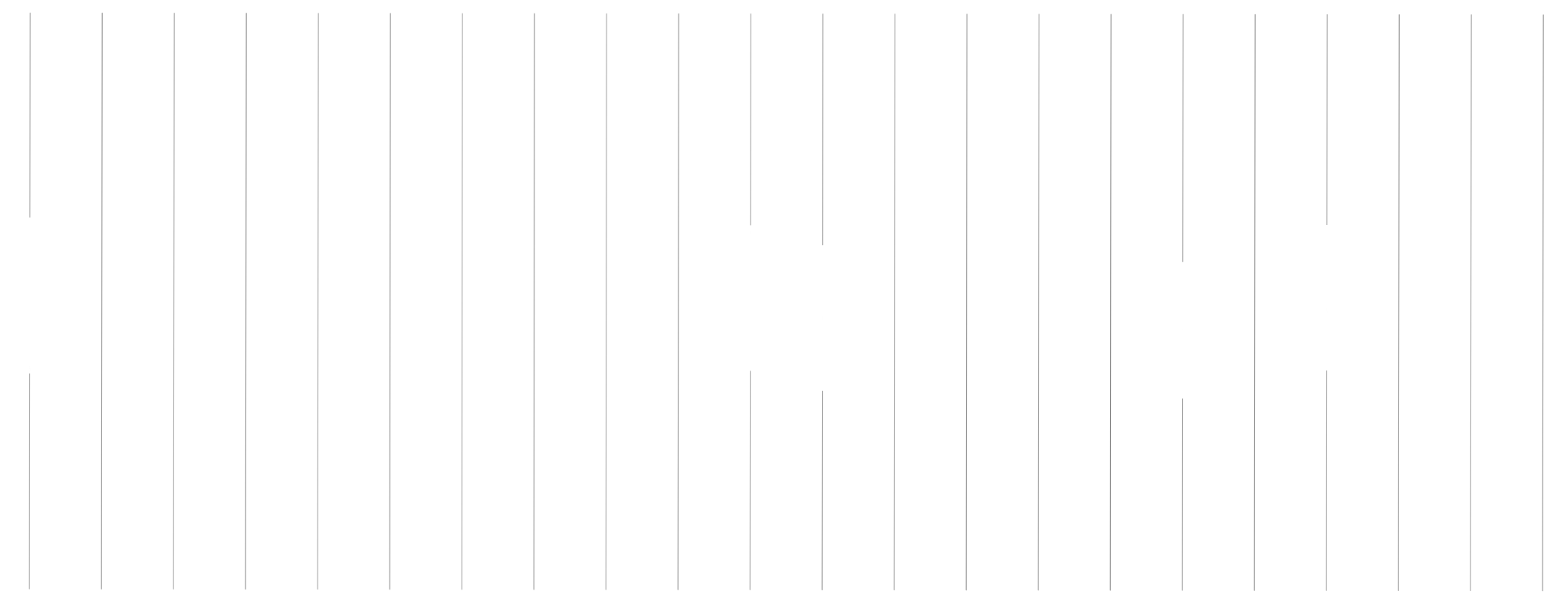
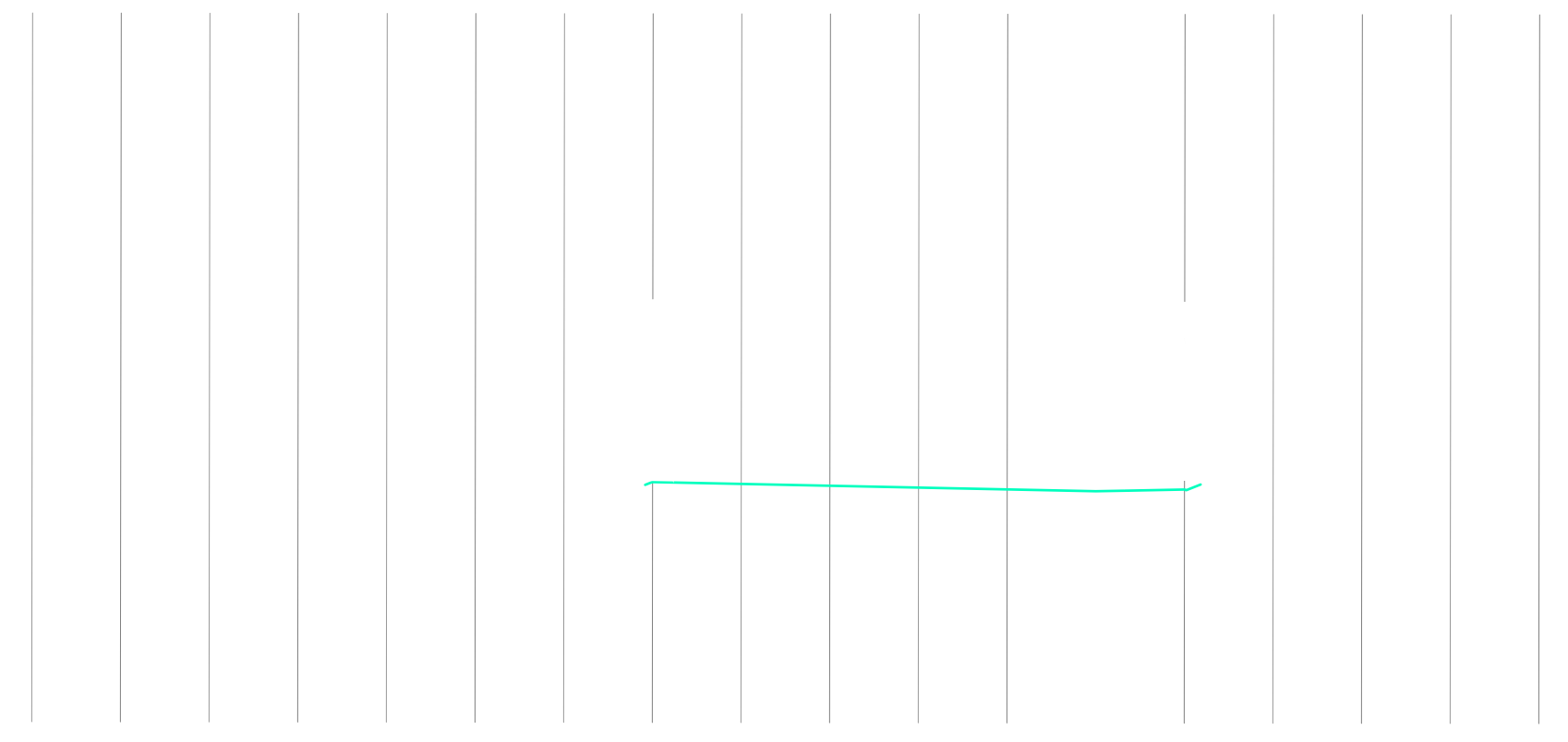

11+95.51

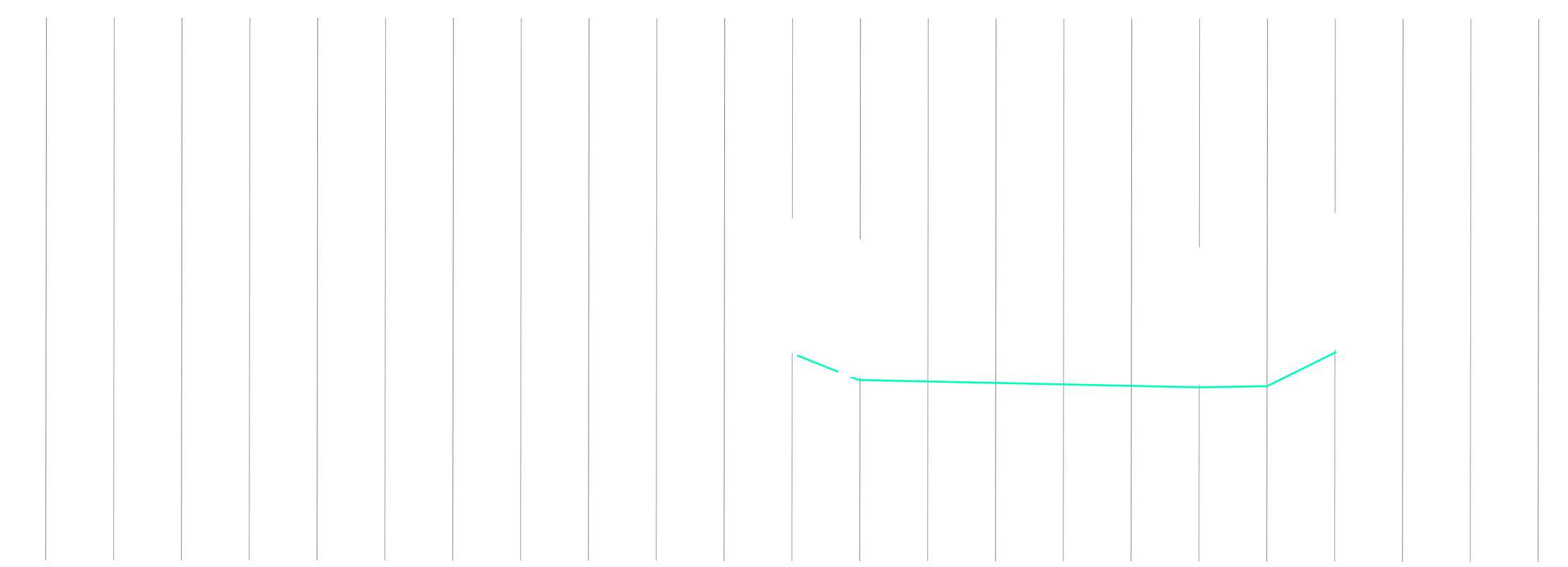
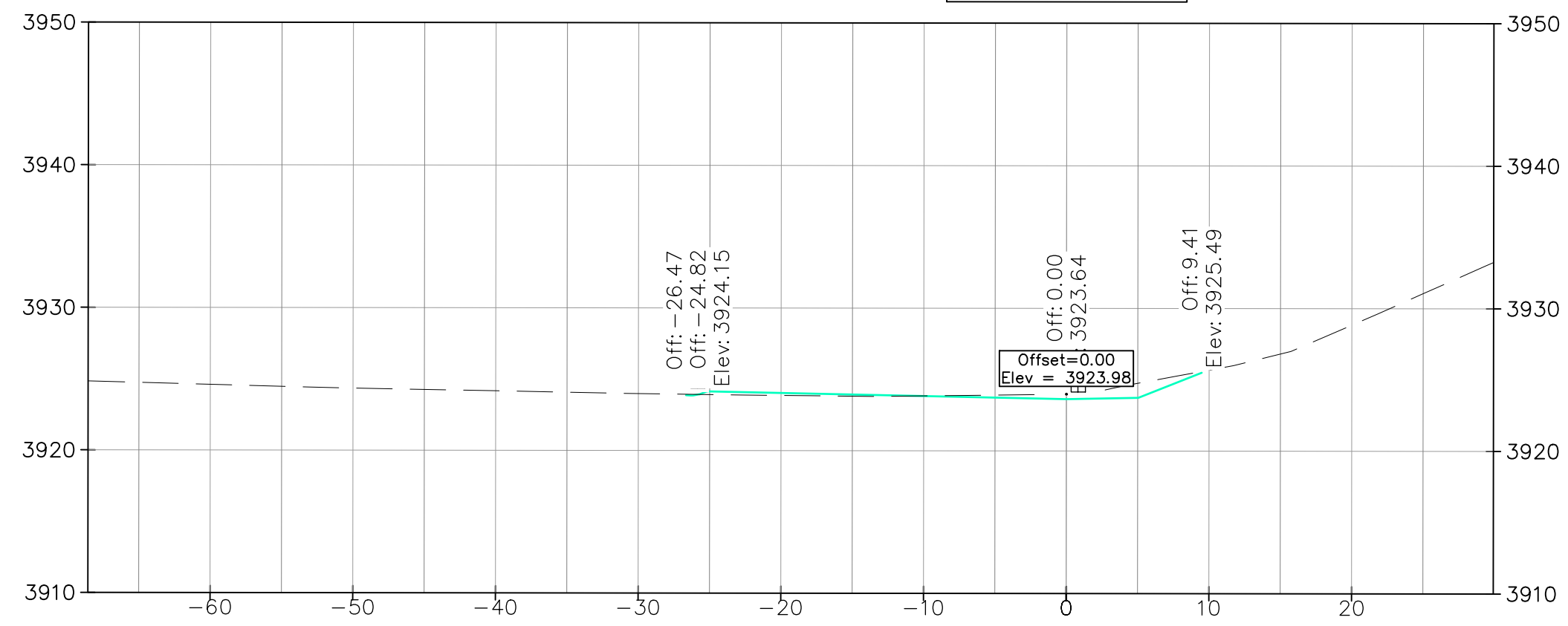

11+45.55

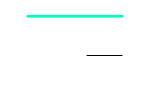
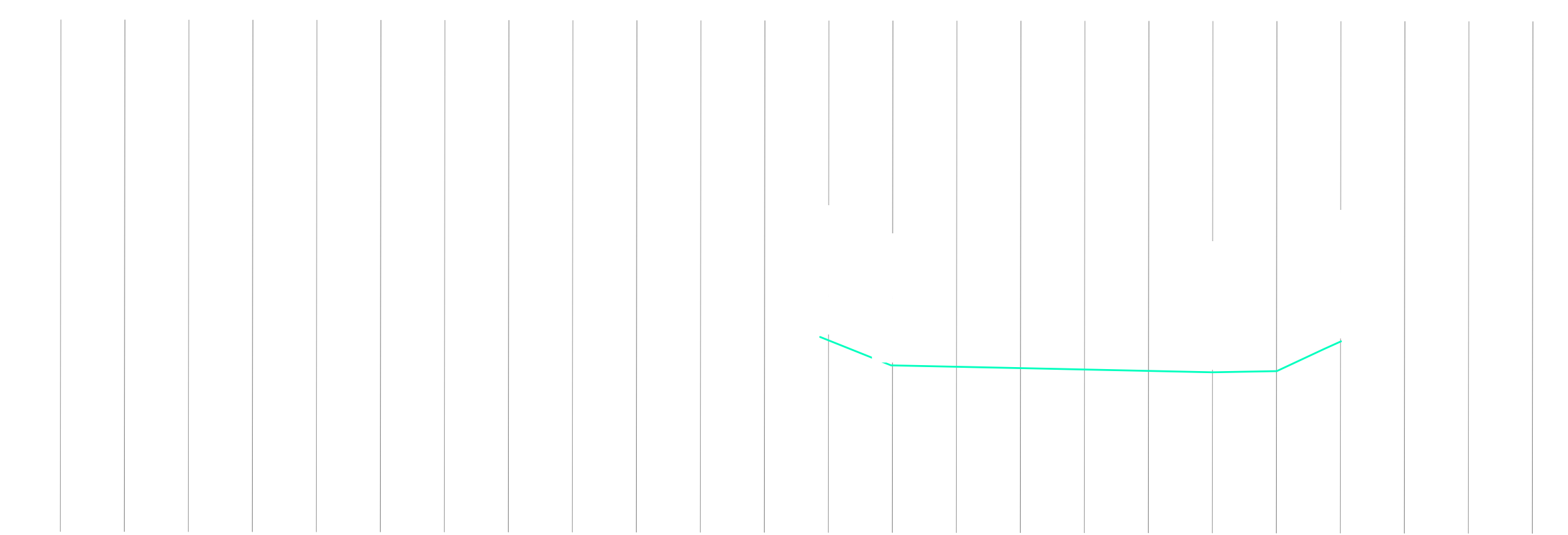
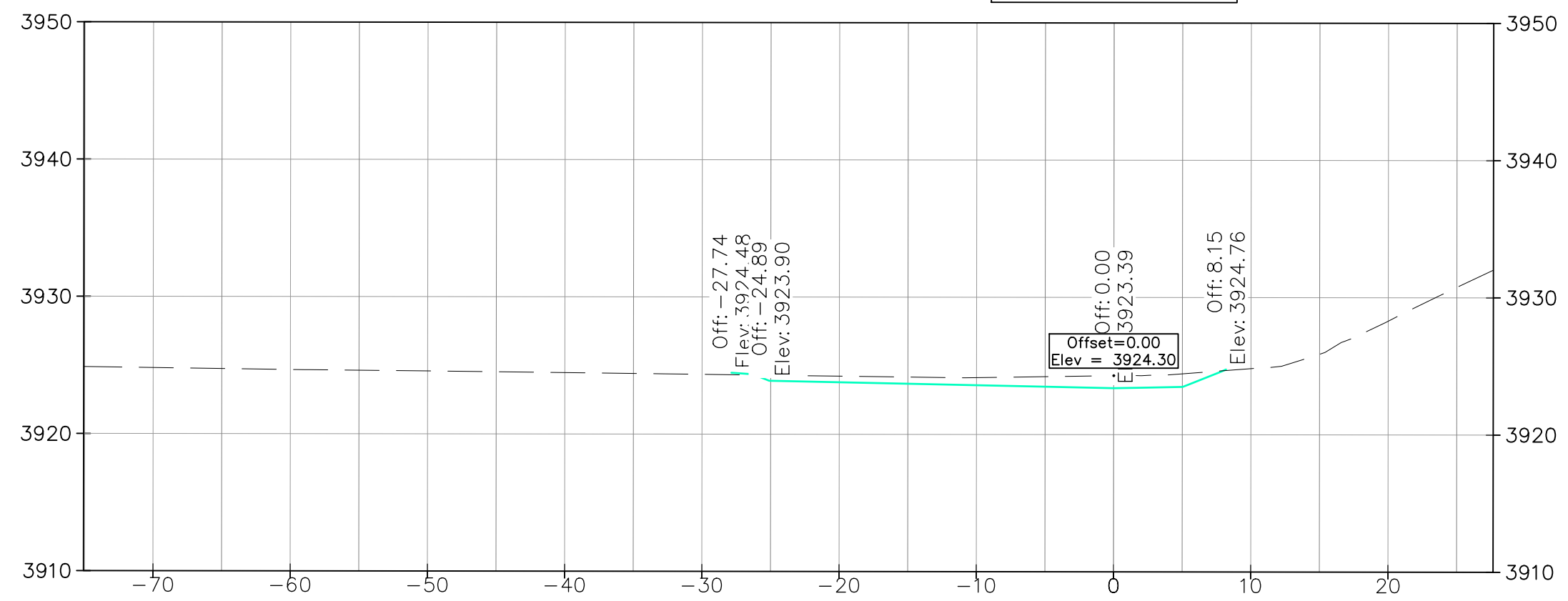

8+42.87

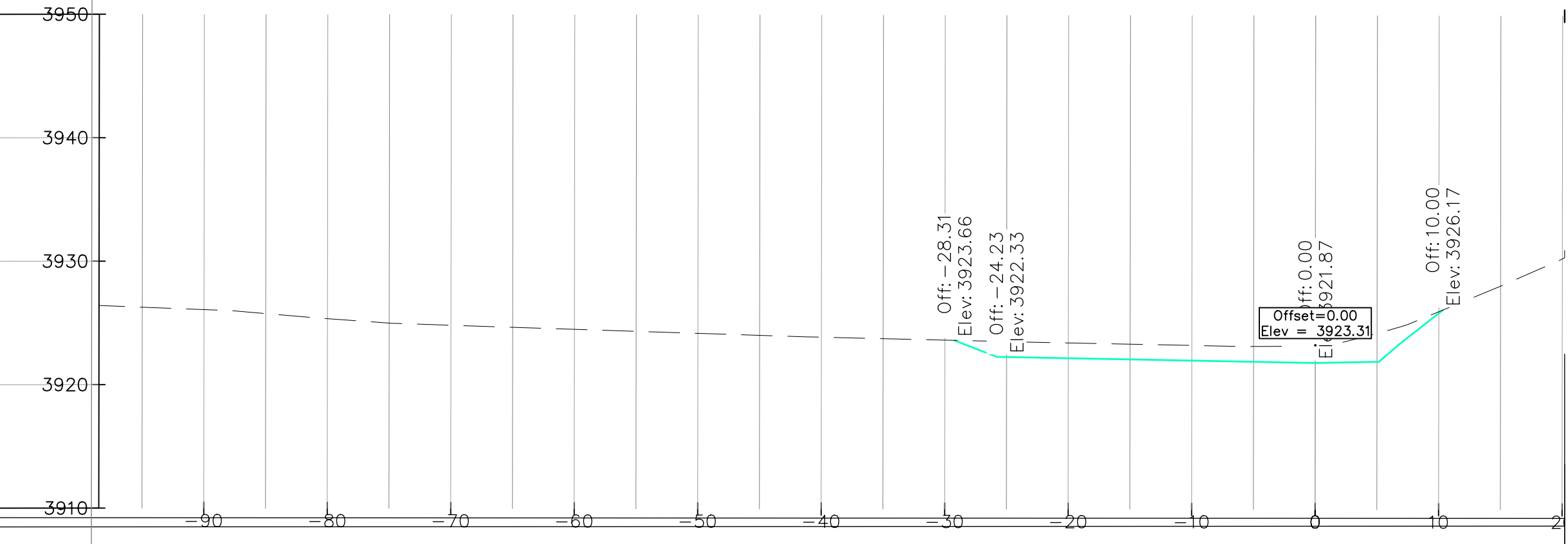

7+94.52

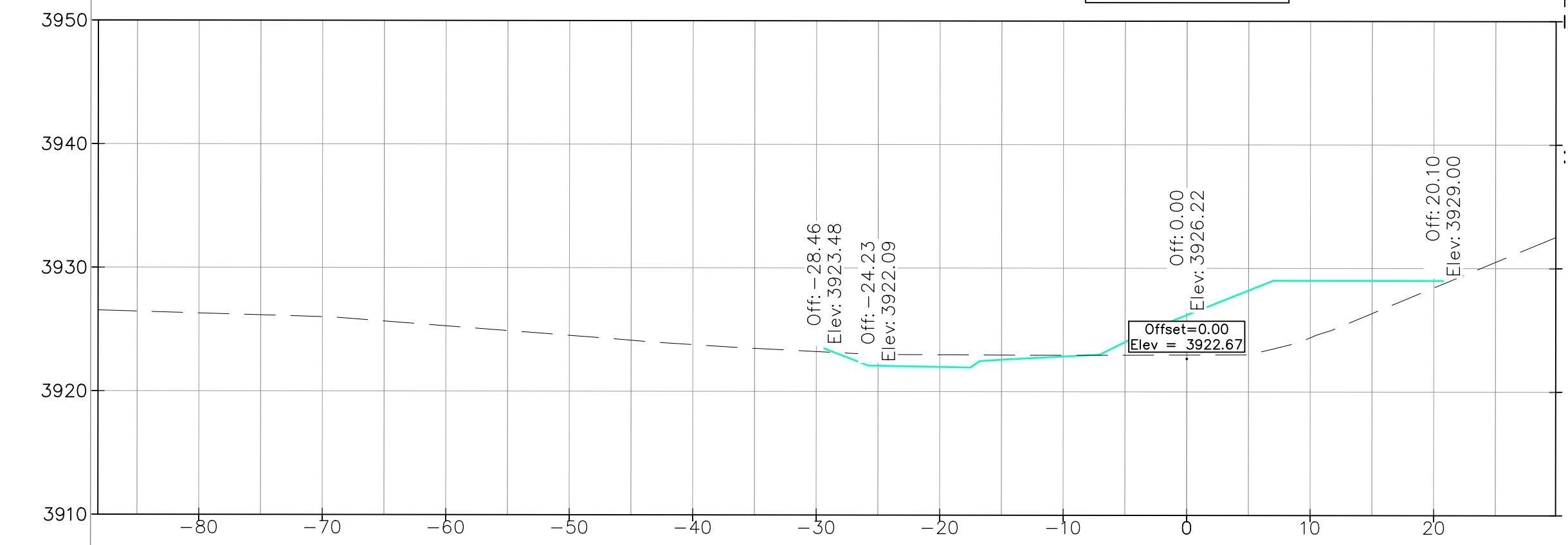

C:\USERS\NATHAN\DROPBOX (S20 DESIGN)\DOCUMENTS\SALMON_ID\DESIGN\ACTIVE DRAWINGS\EAST CHANNEL DESIGN.DWG

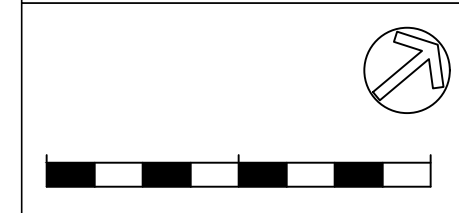
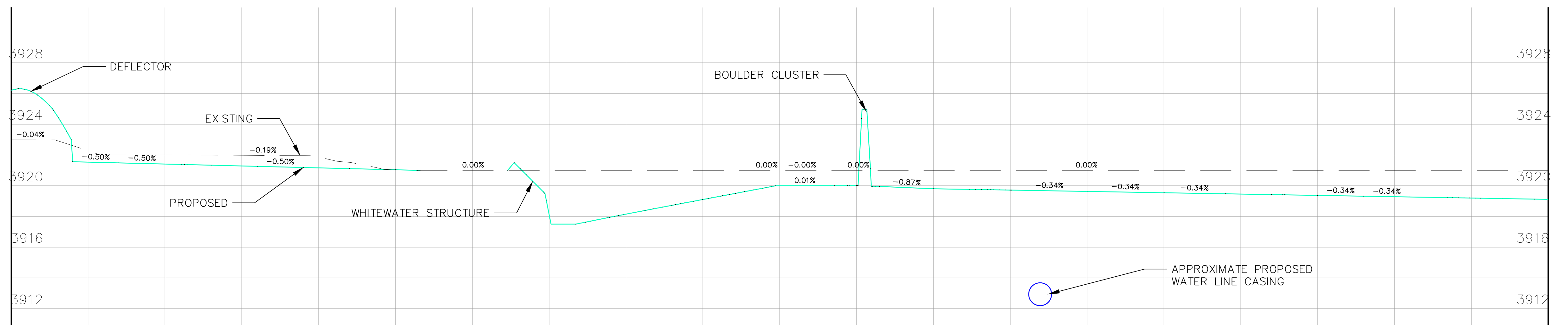
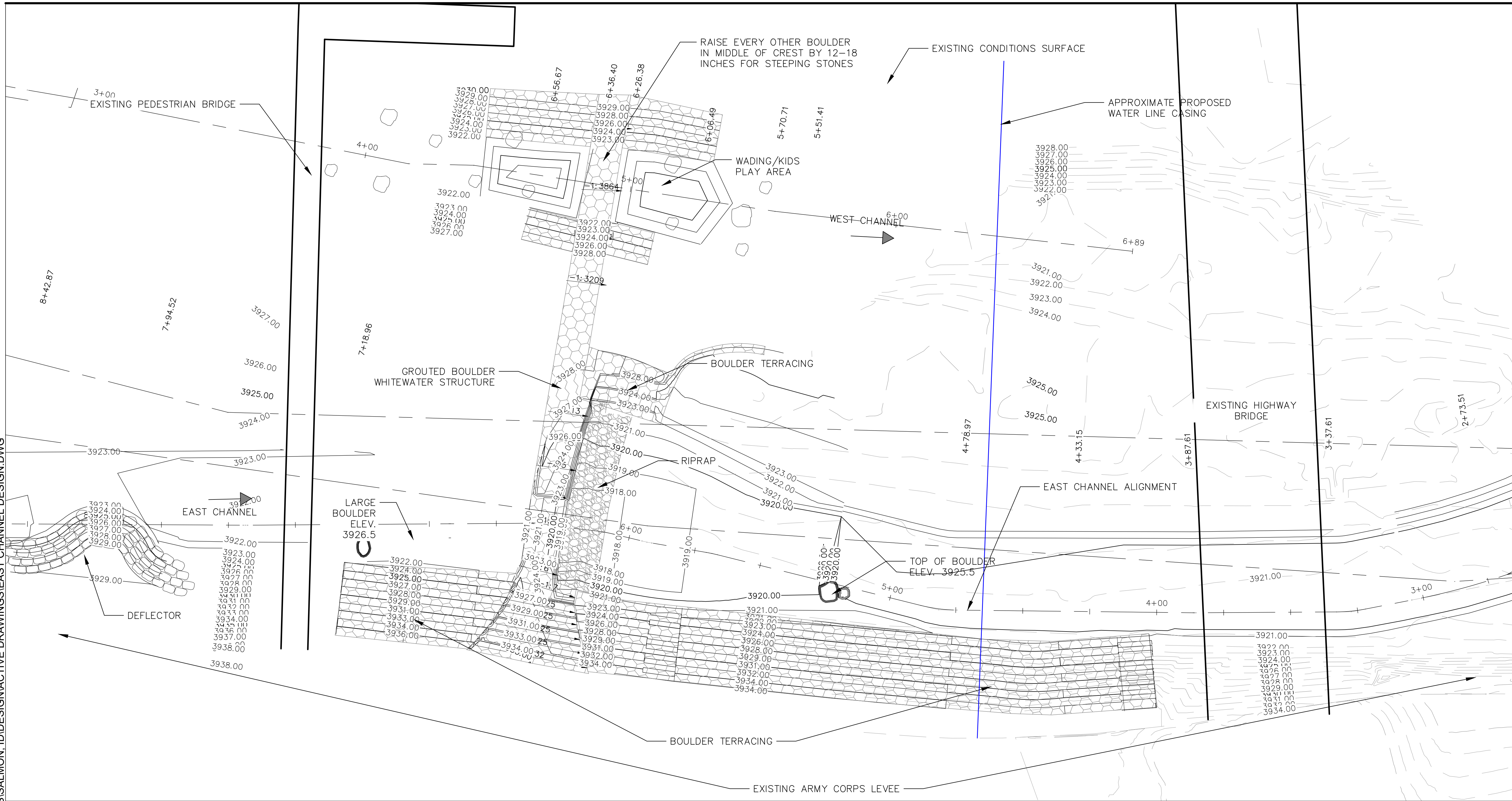

C:\USERS\NATHAN\DROPBOX (S20 DESIGN)\DOCUMENTS\SALMON_ID\DESIGN\ACTIVE DRAWINGS\EAST CHANNEL DESIGN.DWG

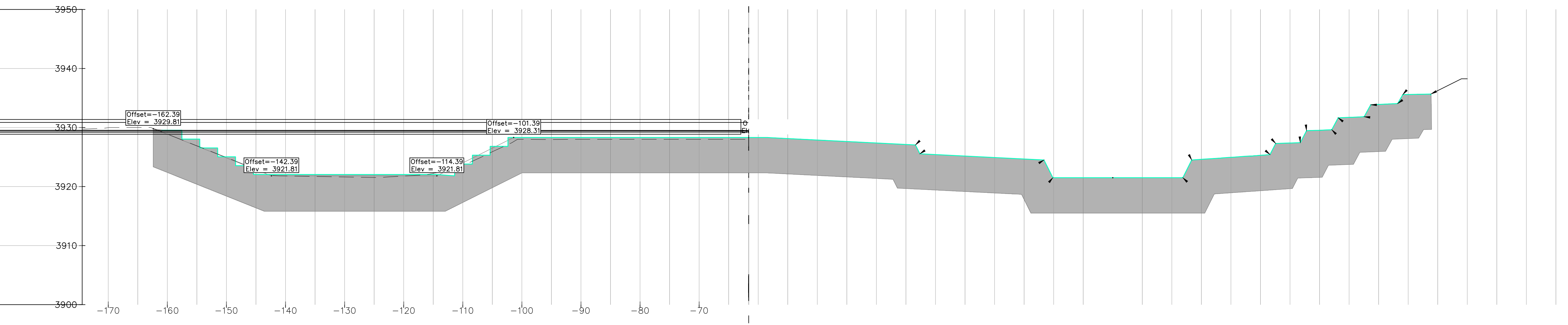
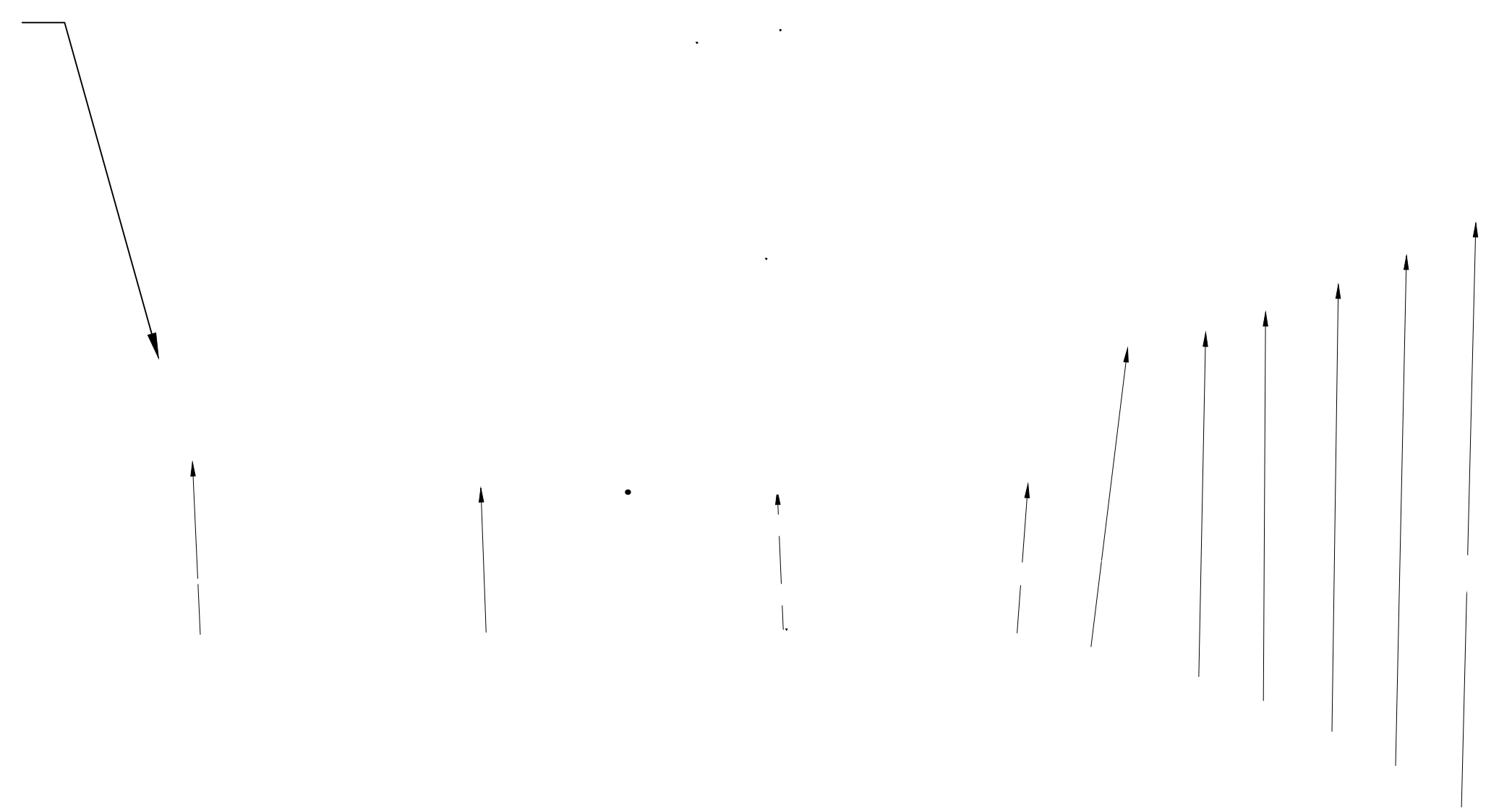
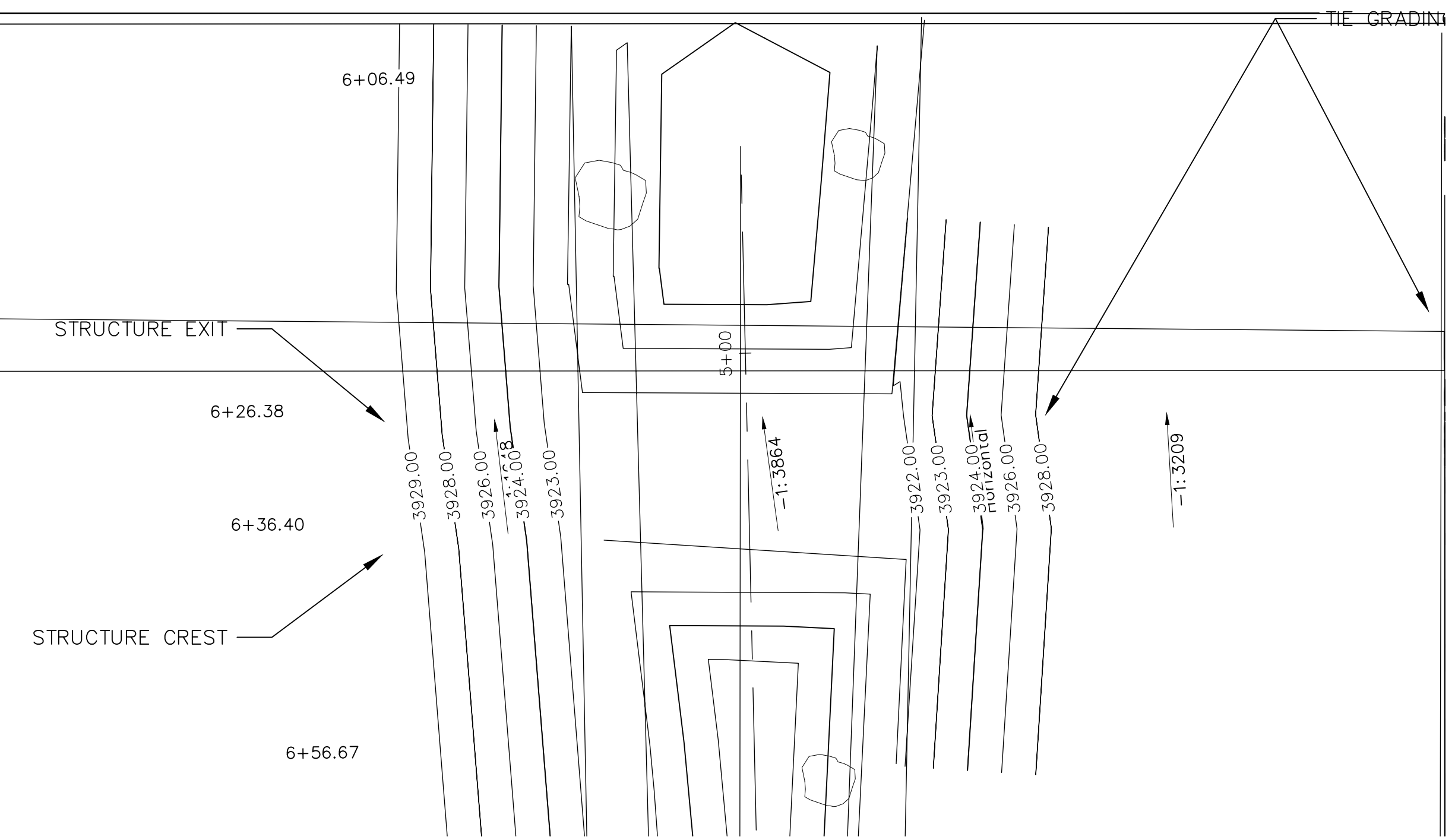
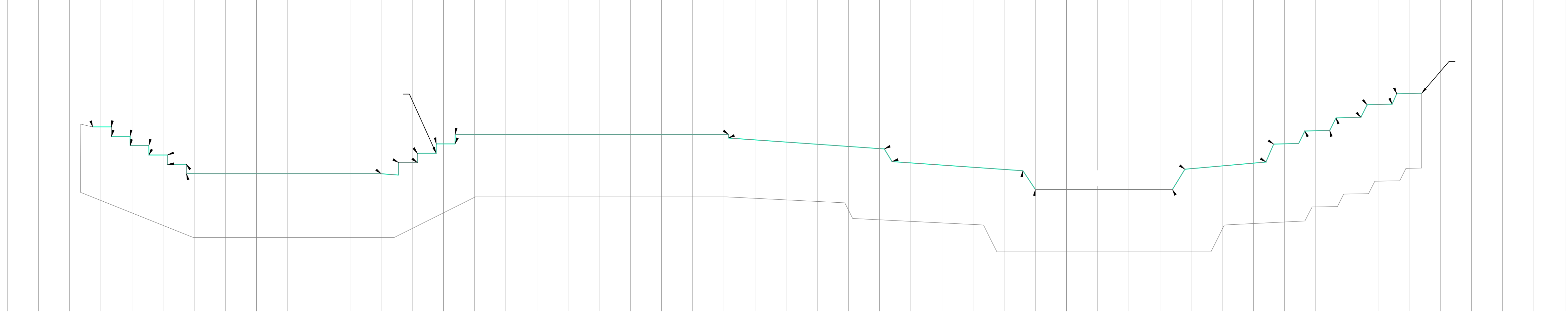

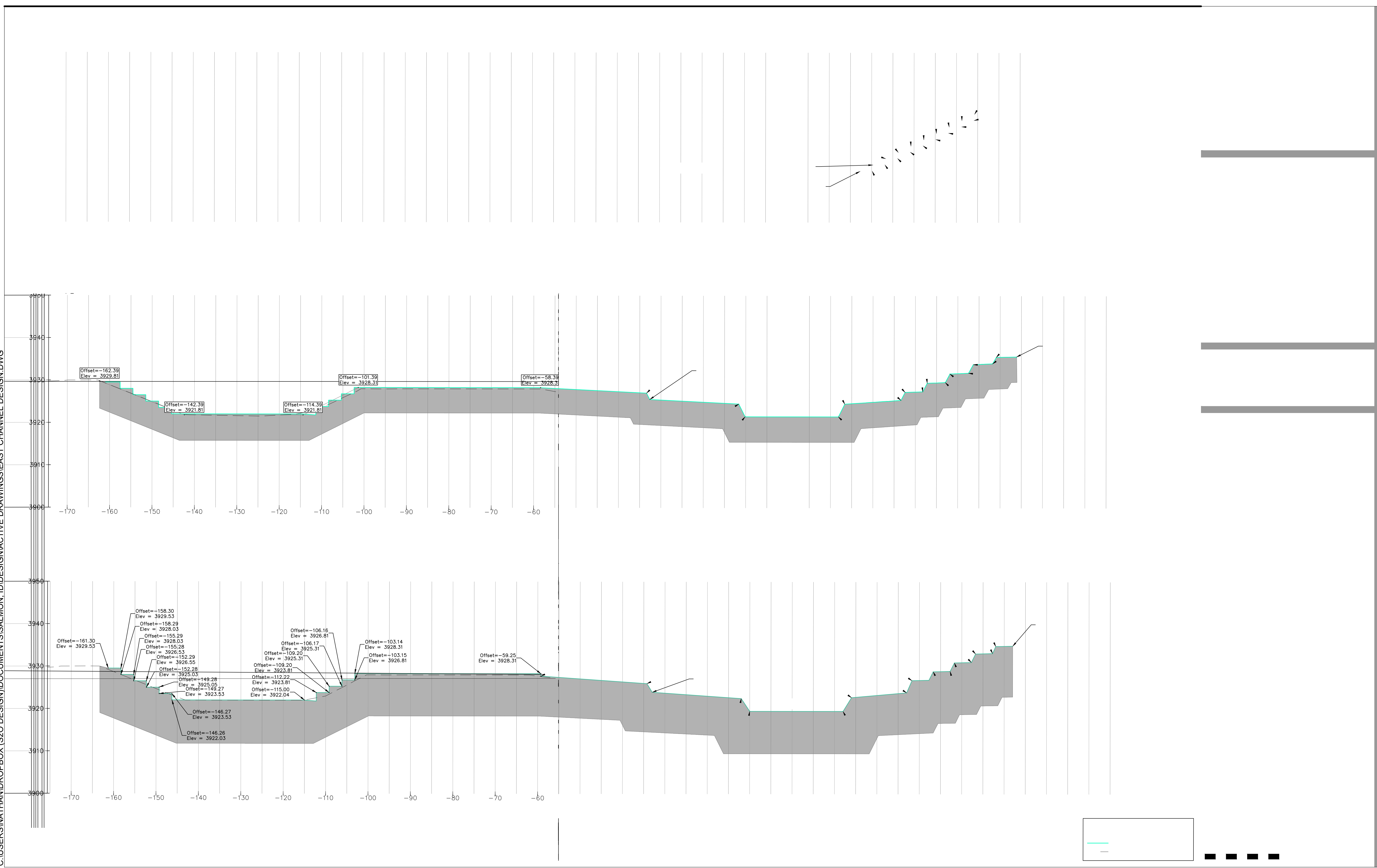

3950
3940
3930
3920
3910

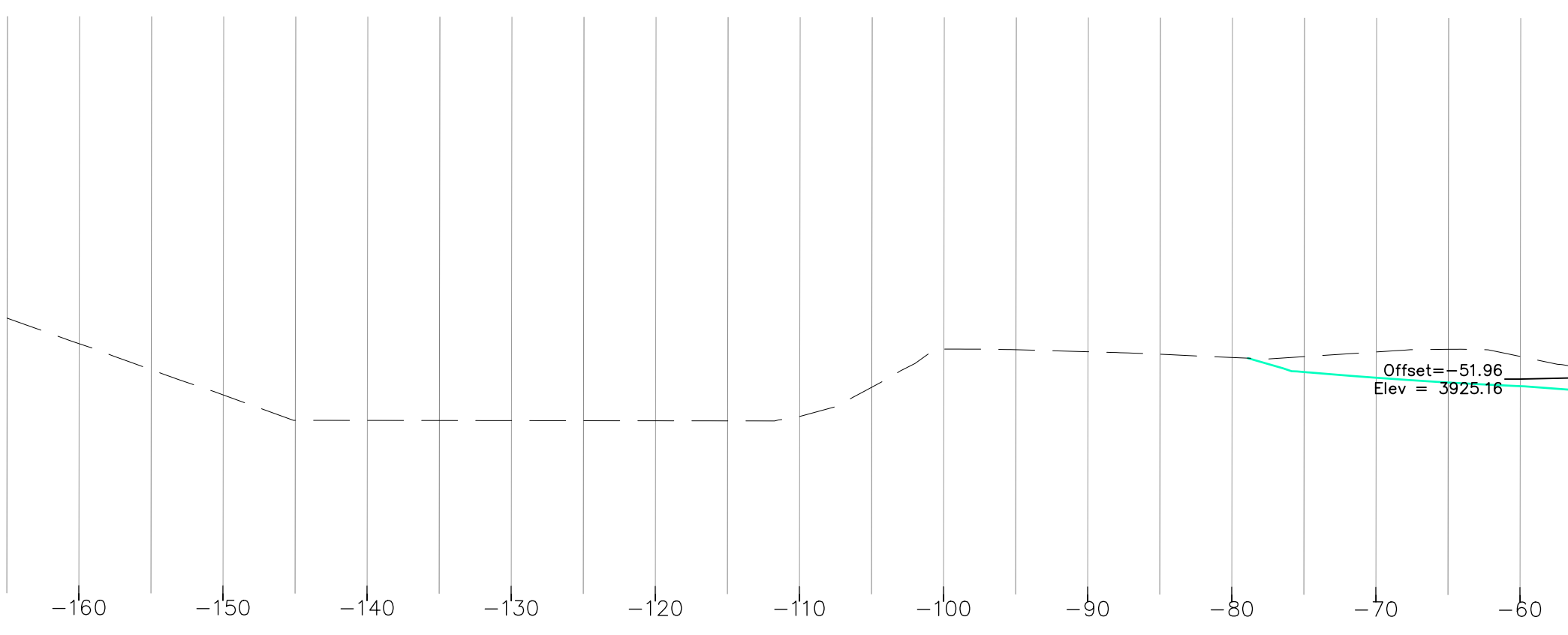

Offset = -51.96
Elev = 3925.16

3950
3940
3930
3920
3910

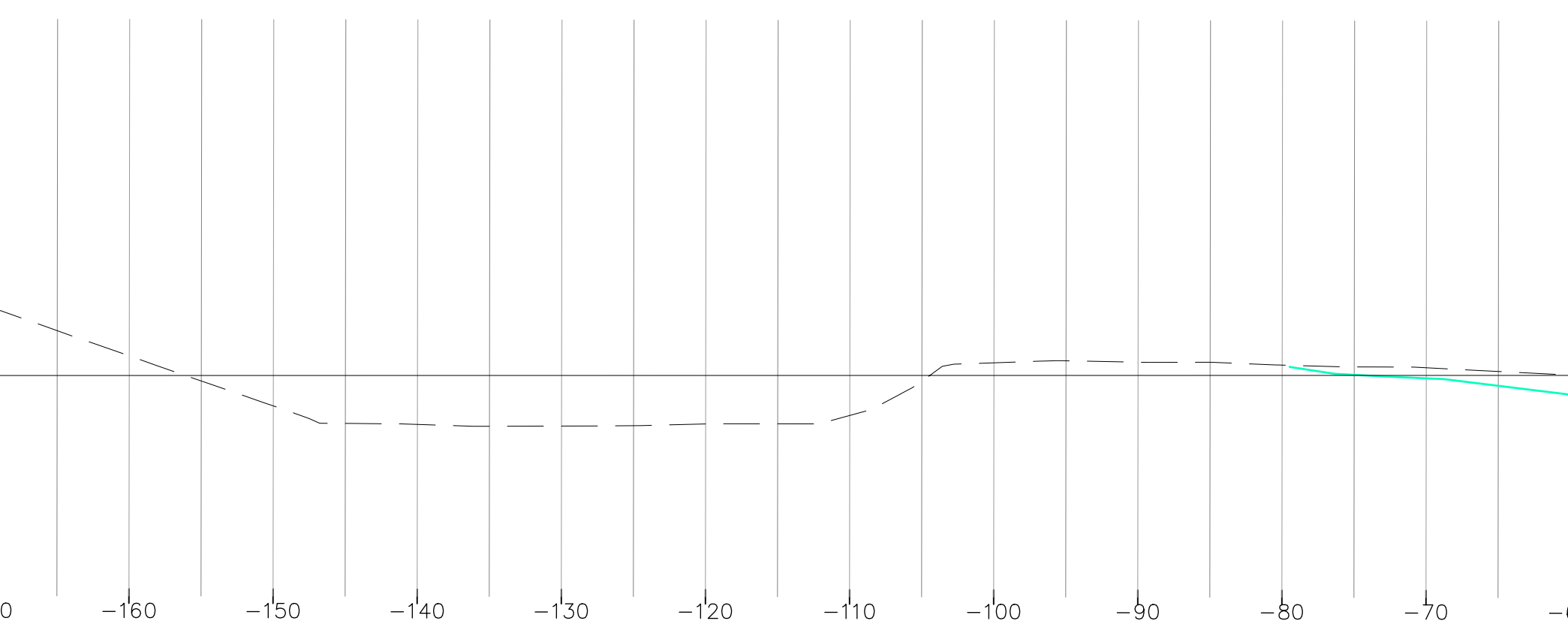

Offset = -51.96
Elev = 3925.16



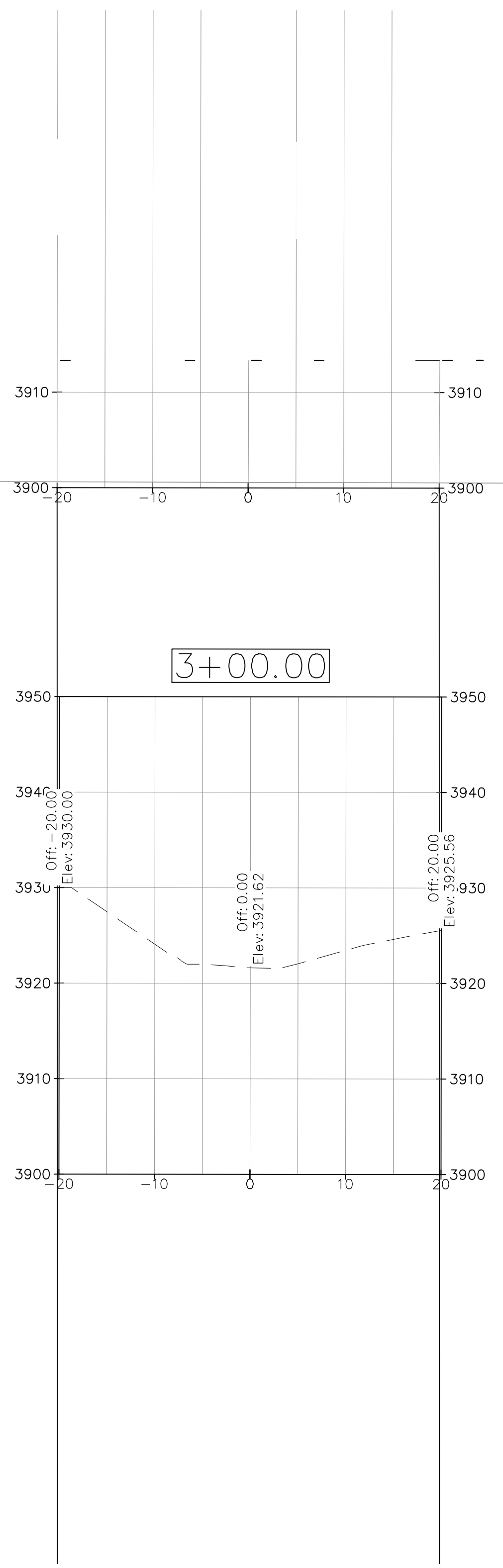
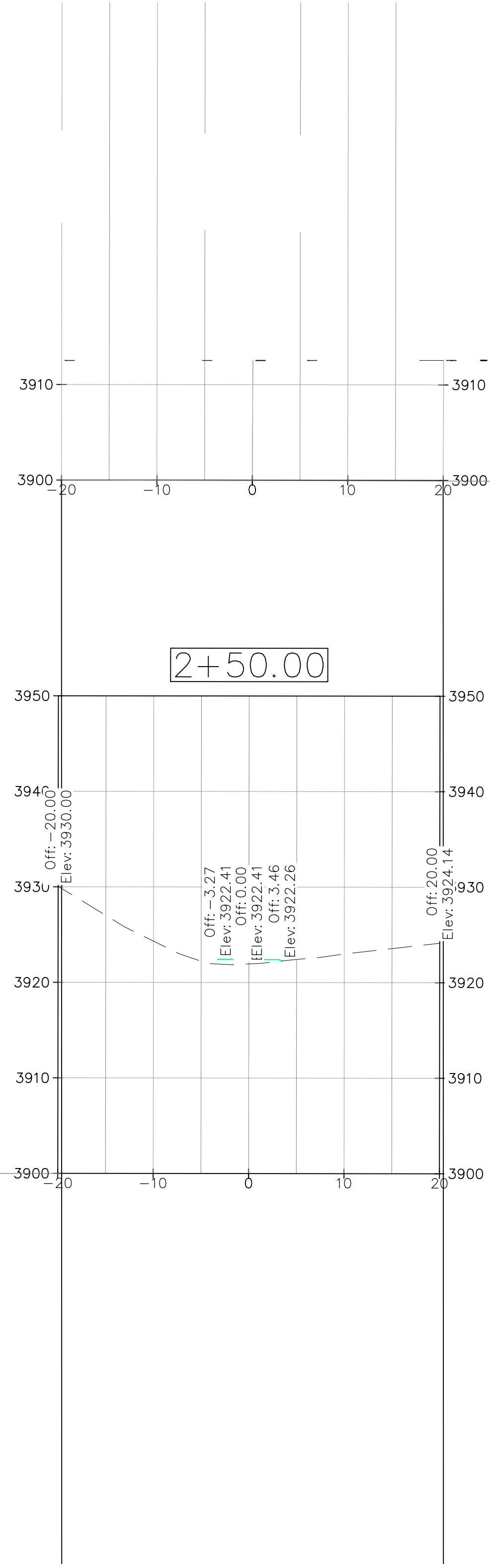

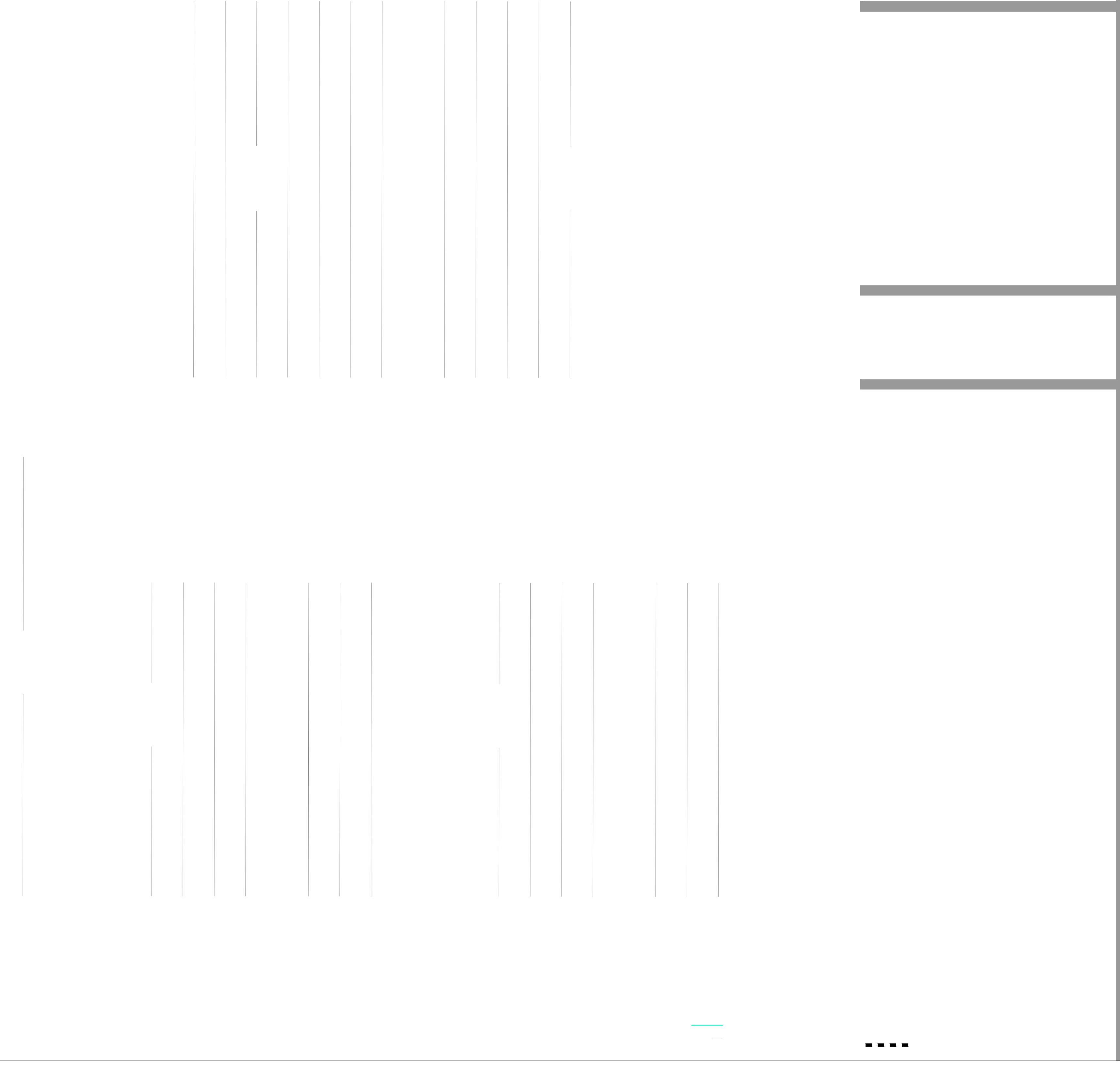
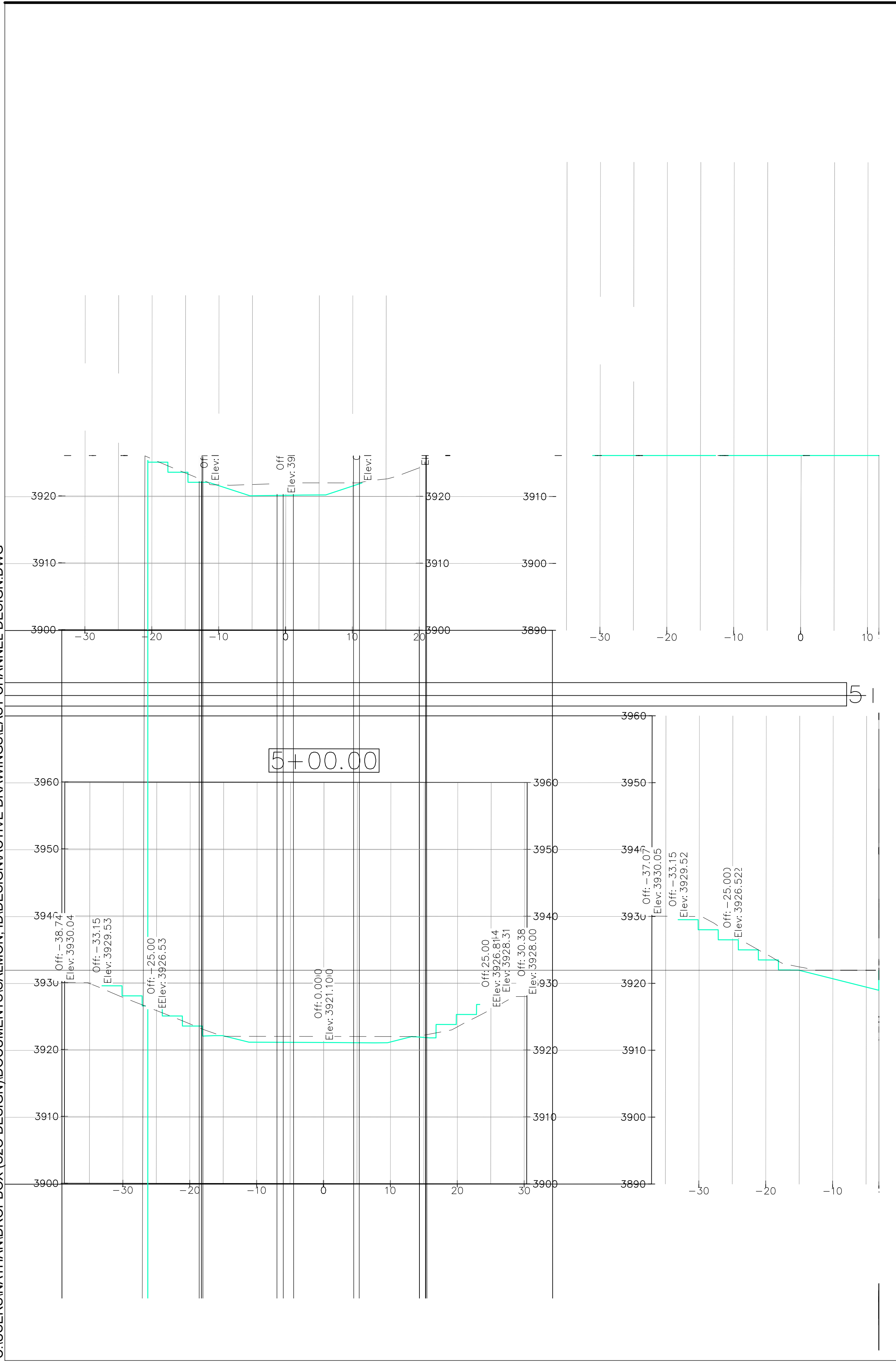

C:\USERS\NATHAN\DROPBOX (S20 DESIGN)\DOCUMENTS\SALMON_ID\DESIGN\ACTIVE DRAWINGS\EAST CHANNEL DESIGN.DWG

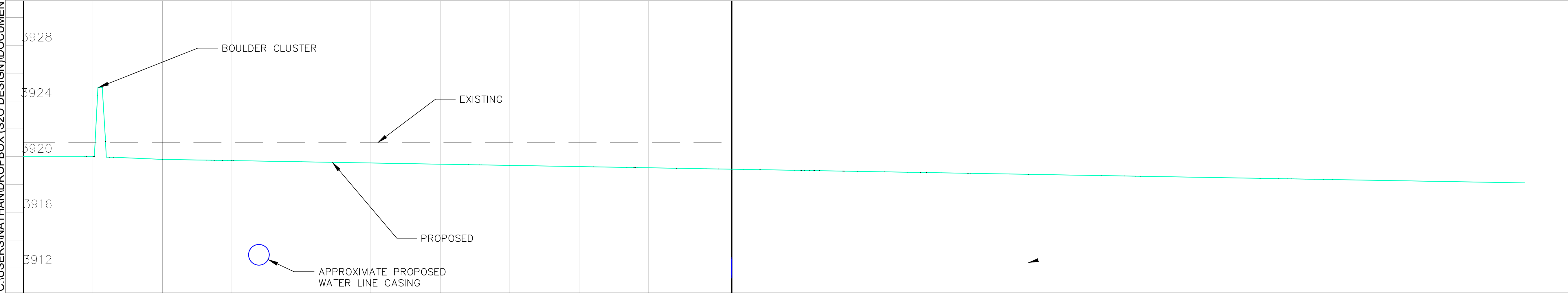
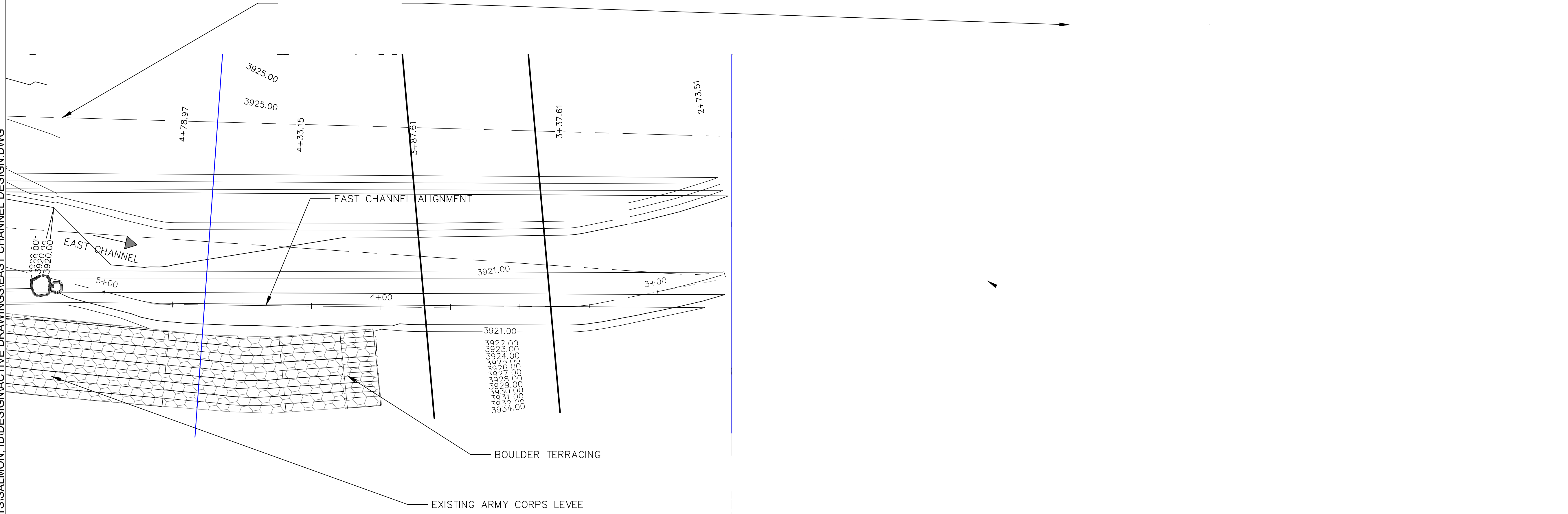

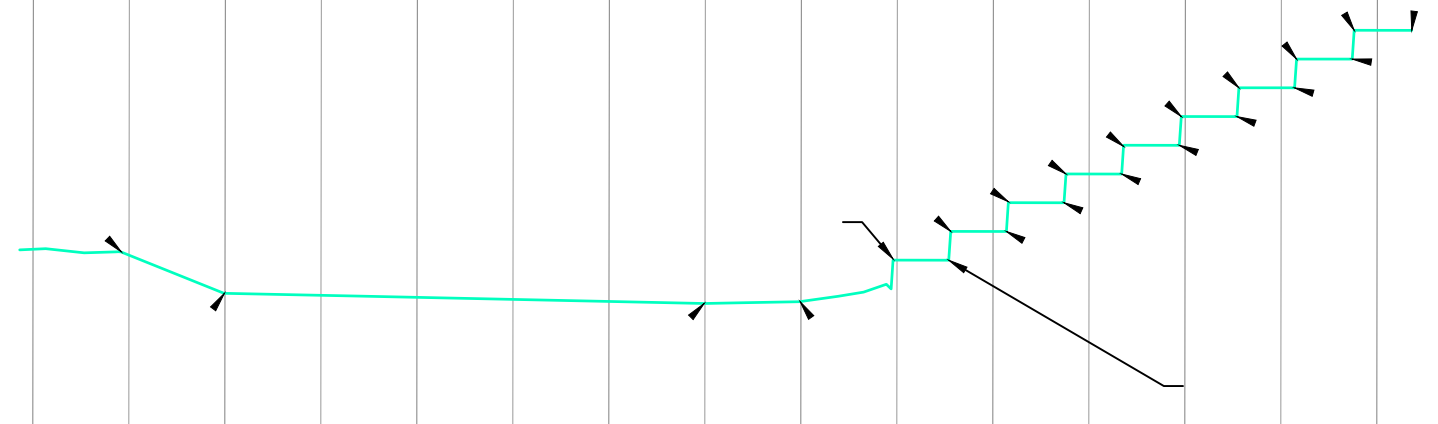

4+33.15

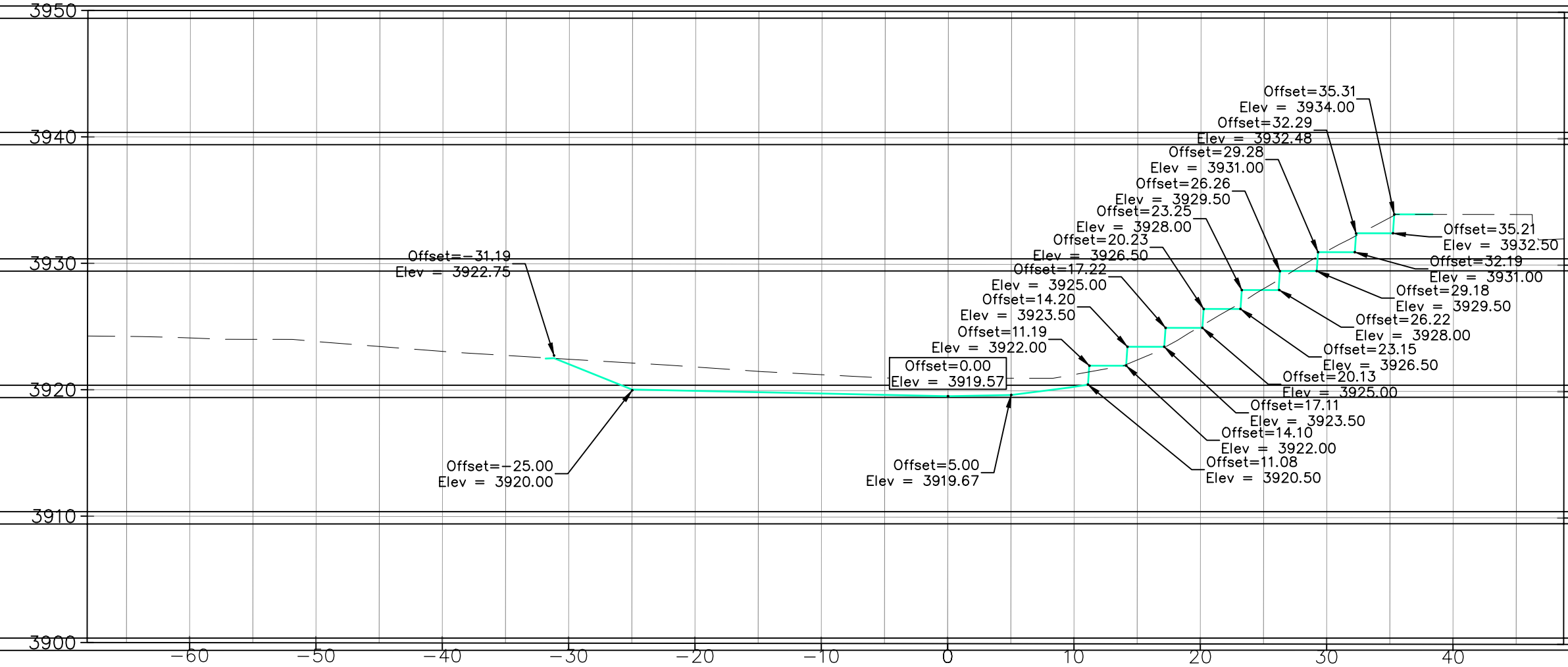

3+87.61

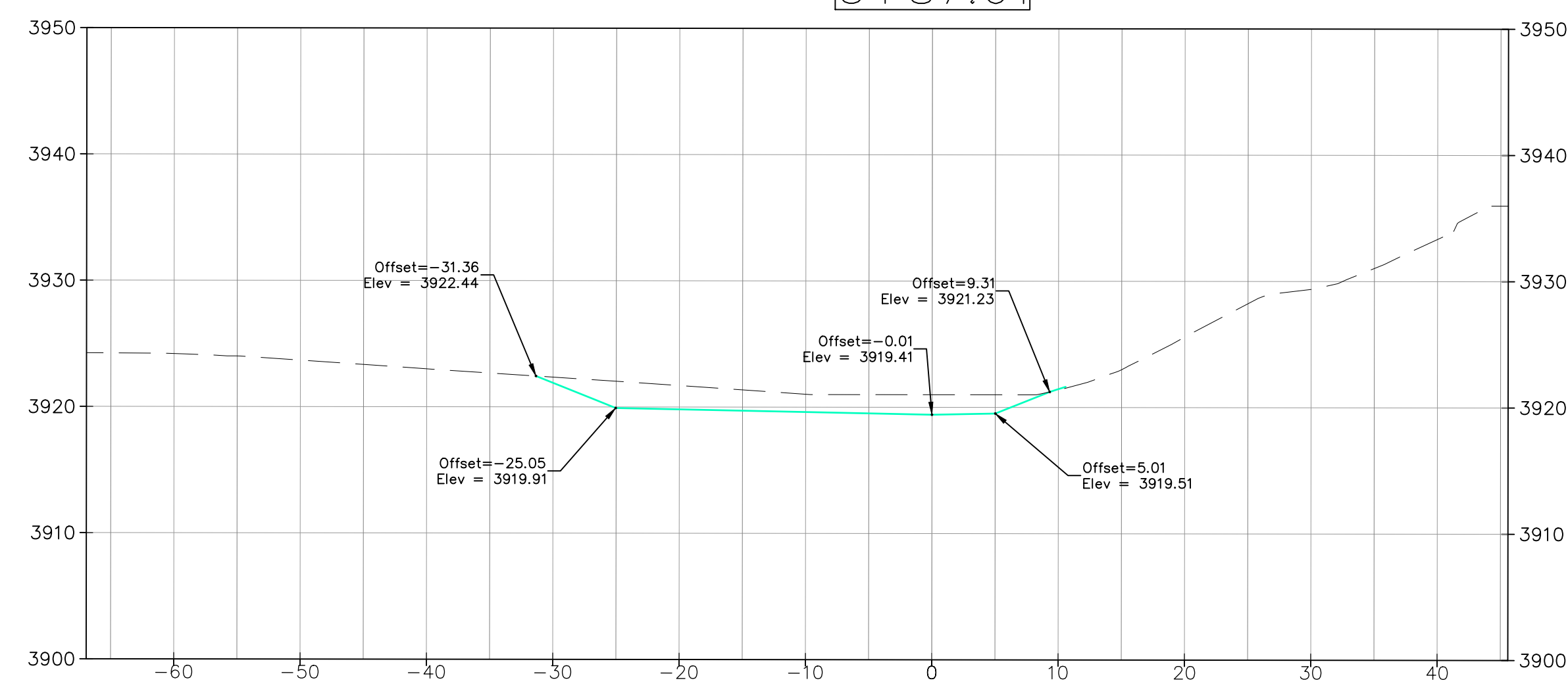

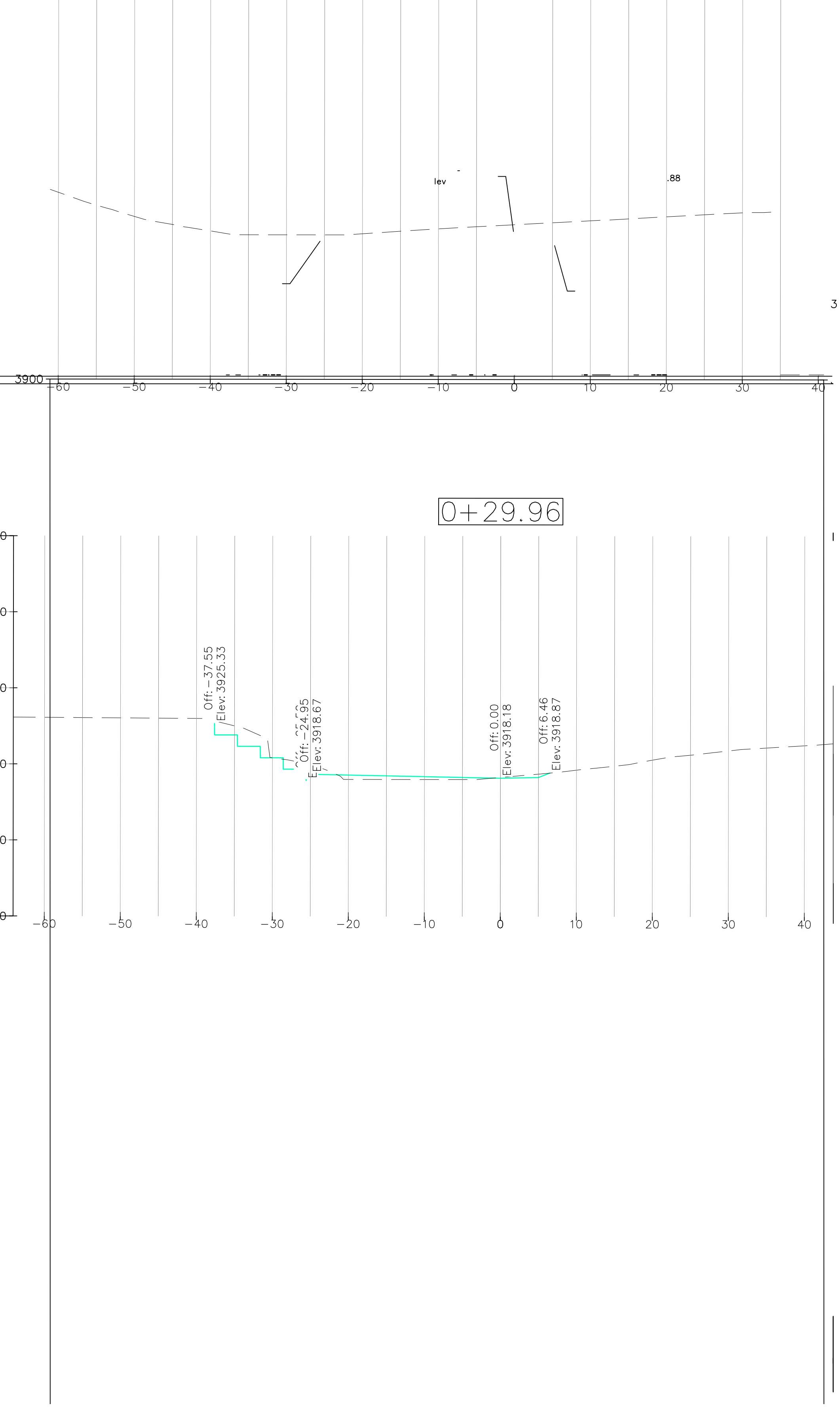

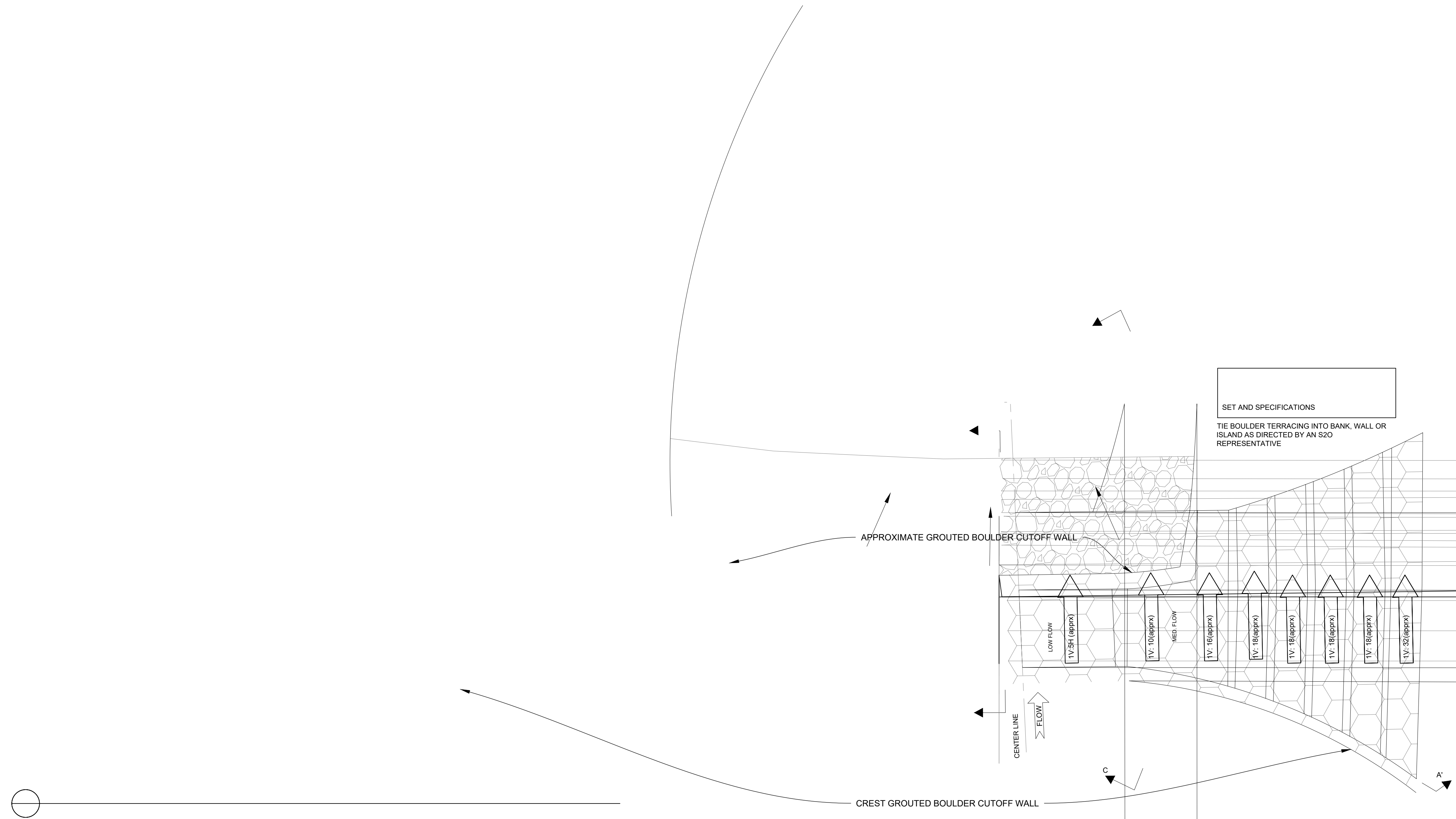

Status:
100% DESIGN DRAWINGS

Drawing Name:
TYPICAL DETAILS

Revisions:
--

Drawn By:
NATHAN WERNER, CHRISTINE CLARK
Checked By:
Scott Shipley

Date:
06/21/2021

Vertical Datum:
NVGD 29
ACOE Project:
NWW-2020-440-102

Stamp:

REUSE OF DOCUMENT:
THIS DOCUMENT IS THE PROPERTY OF S2O DESIGN AND ENGINEERING. THE IDEAS, DESIGN AND CONTENT INCORPORATED ON THIS DOCUMENT IS AN INSTRUMENT OF PROFESSIONAL SERVICE AND SHALL NOT BE USED FOR ANY OTHER PROJECT WITHOUT THE WRITTEN AUTHORIZATION OF S2O DESIGN AND ENGINEERING.

Scale: Sheet:
WW-6.0
22 of 32

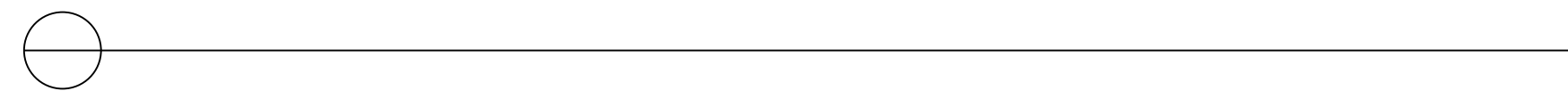
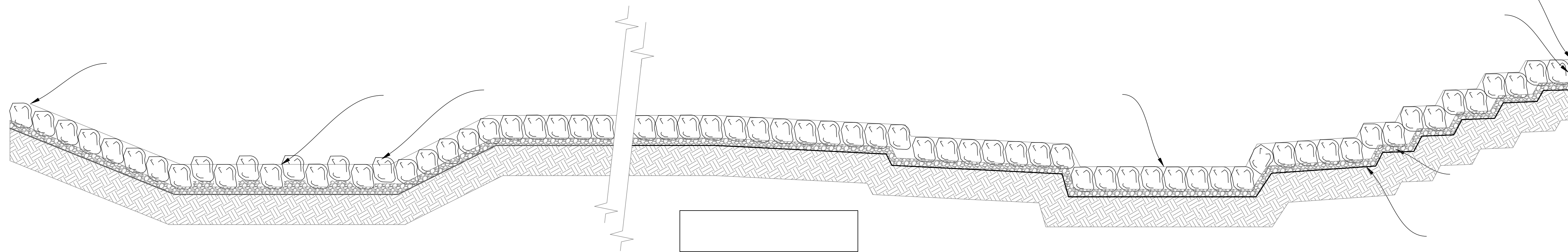

Status:
100% DESIGN DRAWINGS

Drawing Name:
TYPICAL DETAILS

Revisions:
--

Drawn By:
NATHAN WERNER, CHRISTINE CLARK

Checked By:
Scott Shipley

Date:
06/21/2021

Vertical Datum:
NVGD 29
ACOE Project:
NWW-2020-440-I02

Stamp:

REUSE OF DOCUMENT:
THIS DOCUMENT IS THE PROPERTY OF ISO DESIGN AND ENGINEERING. THE IDEAS, DESIGN
AND CONTENT INCORPORATED ON THIS DOCUMENT IS AN INSTRUMENT OF PROFESSIONAL
SERVICE AND SHALL NOT BE USED FOR ANY OTHER PROJECT WITHOUT THE WRITTEN
AUTHORIZATION OF ISO DESIGN AND ENGINEERING.

Scale:

Sheet:
WW-6.1
23 of 32

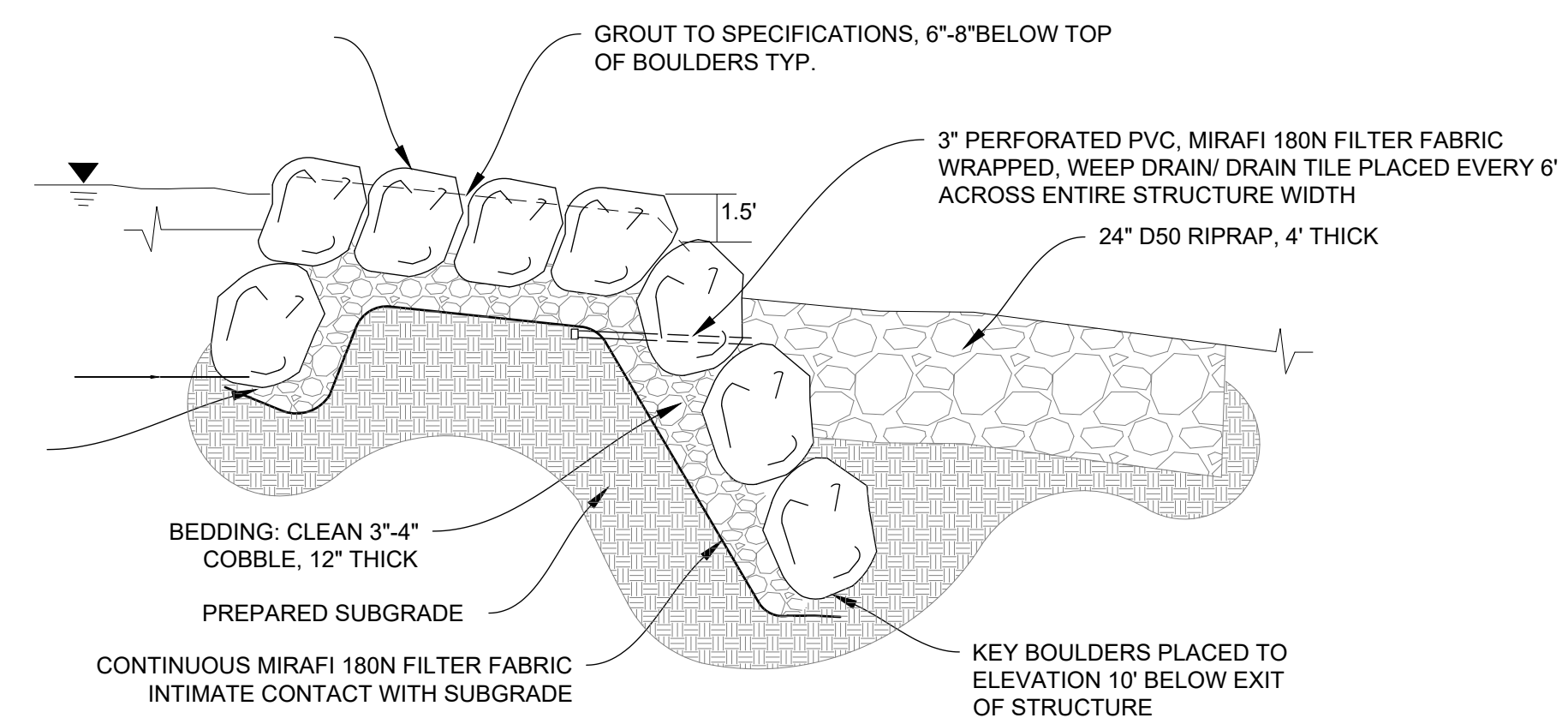
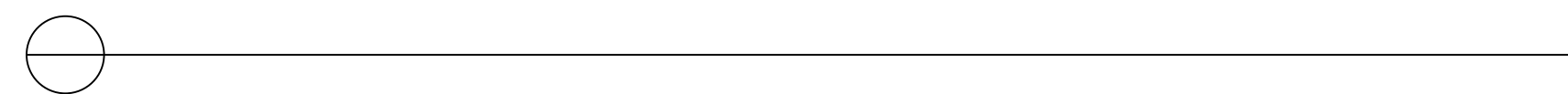
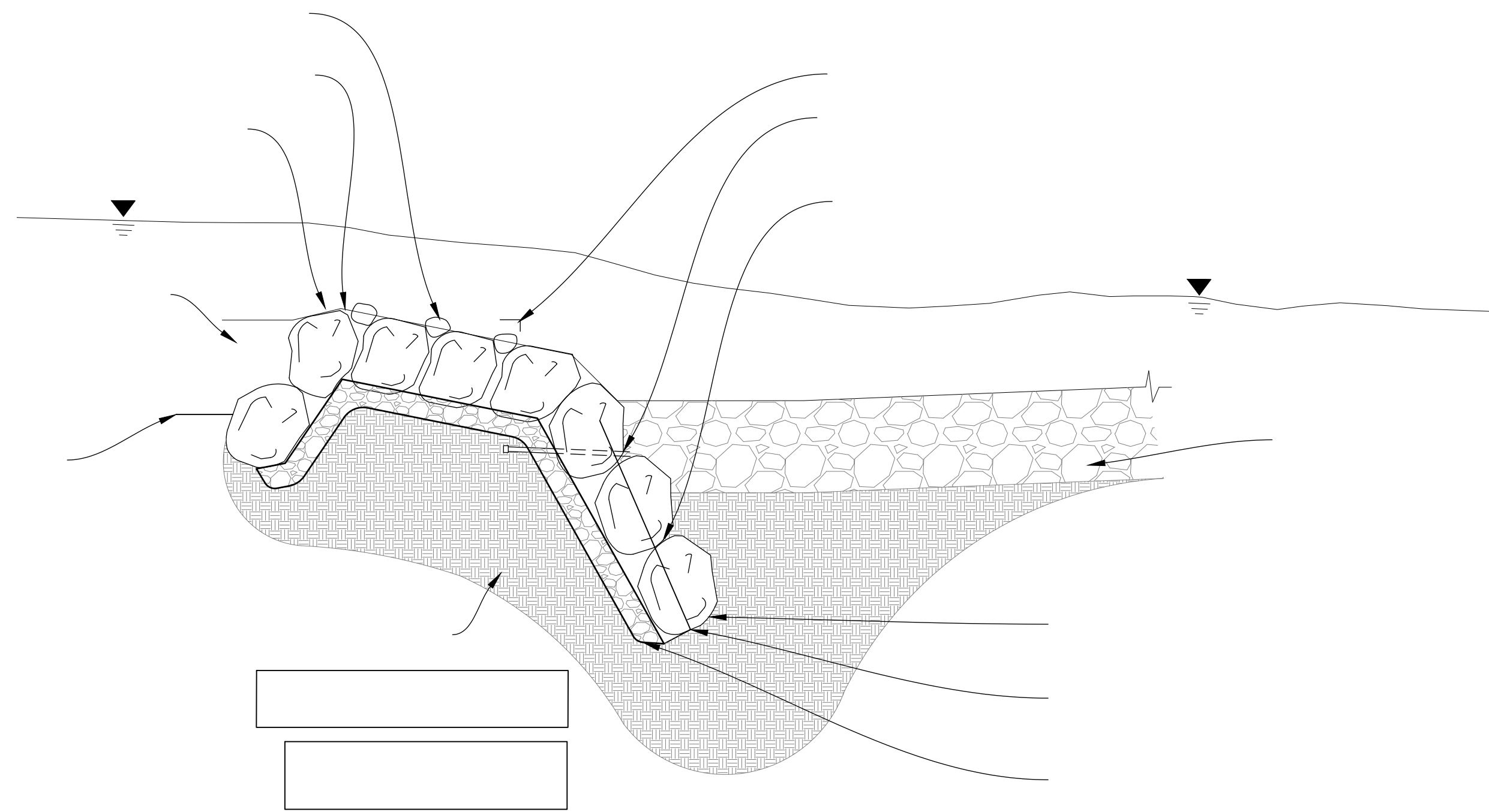

WHITewater STRUCTURE (STRUCTURE): WING (TYP.)

SCALE: 1:5

Status:
100% DESIGN DRAWINGS

Drawing Name:
TYPICAL DETAILS

Revisions:
--

Drawn By:
NATHAN WERNER, CHRISTINE CLARK
Checked By:
Scott Shipley

Date:
06/21/2021

Vertical Datum:
NVGD 29
ACOE Project:
NWW-2020-440-102

Stamp:

REUSE OF DOCUMENT:
THIS DOCUMENT IS THE PROPERTY OF ISO DESIGN AND ENGINEERING. THE IDEAS, DESIGN
AND CONTENT INCORPORATED ON THIS DOCUMENT IS AN INSTRUMENT OF PROFESSIONAL
SERVICE AND SHALL NOT BE USED FOR ANY OTHER PROJECT WITHOUT THE WRITTEN
AUTHORIZATION OF ISO DESIGN AND ENGINEERING.

Scale: Sheet:
WW-6.2
24 of 32

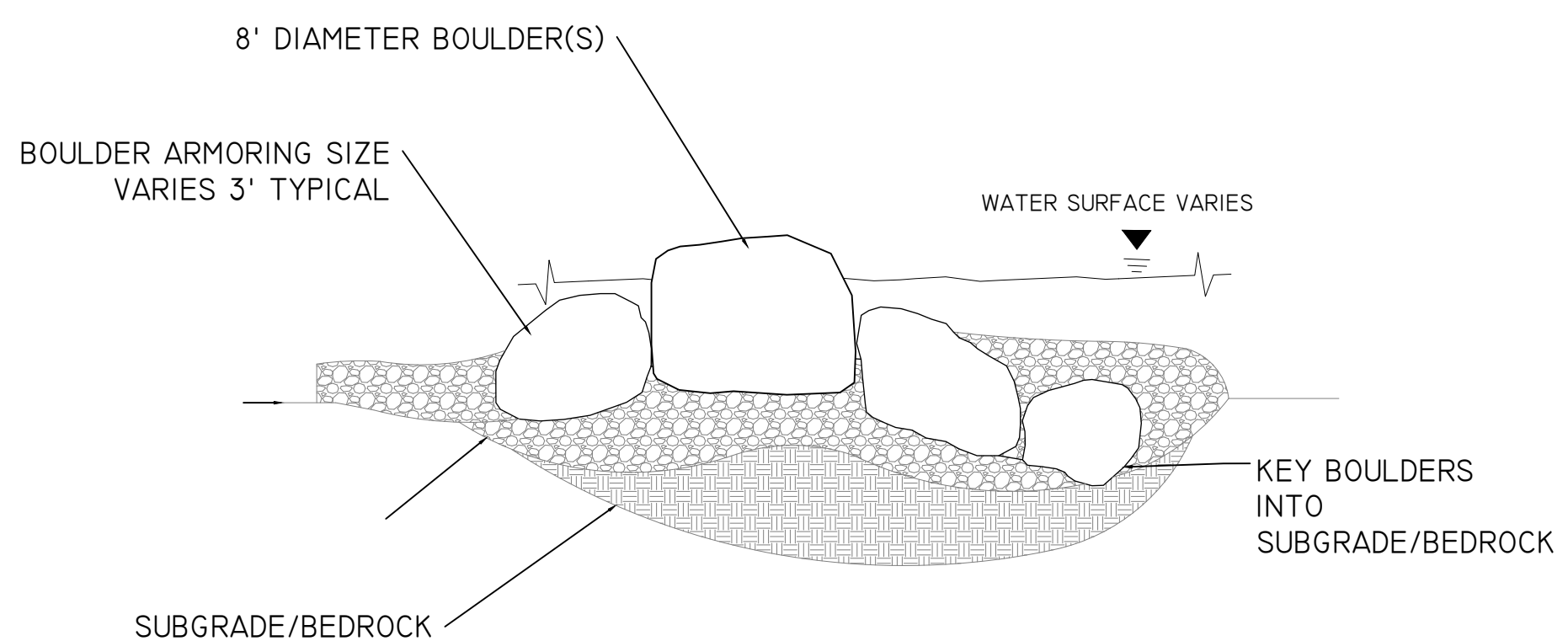
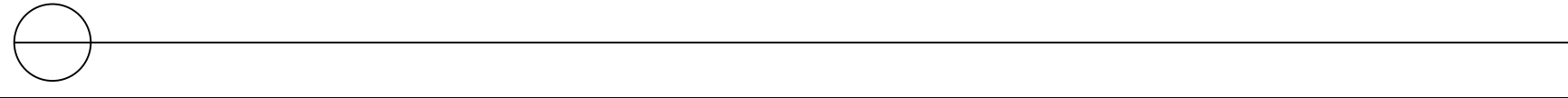
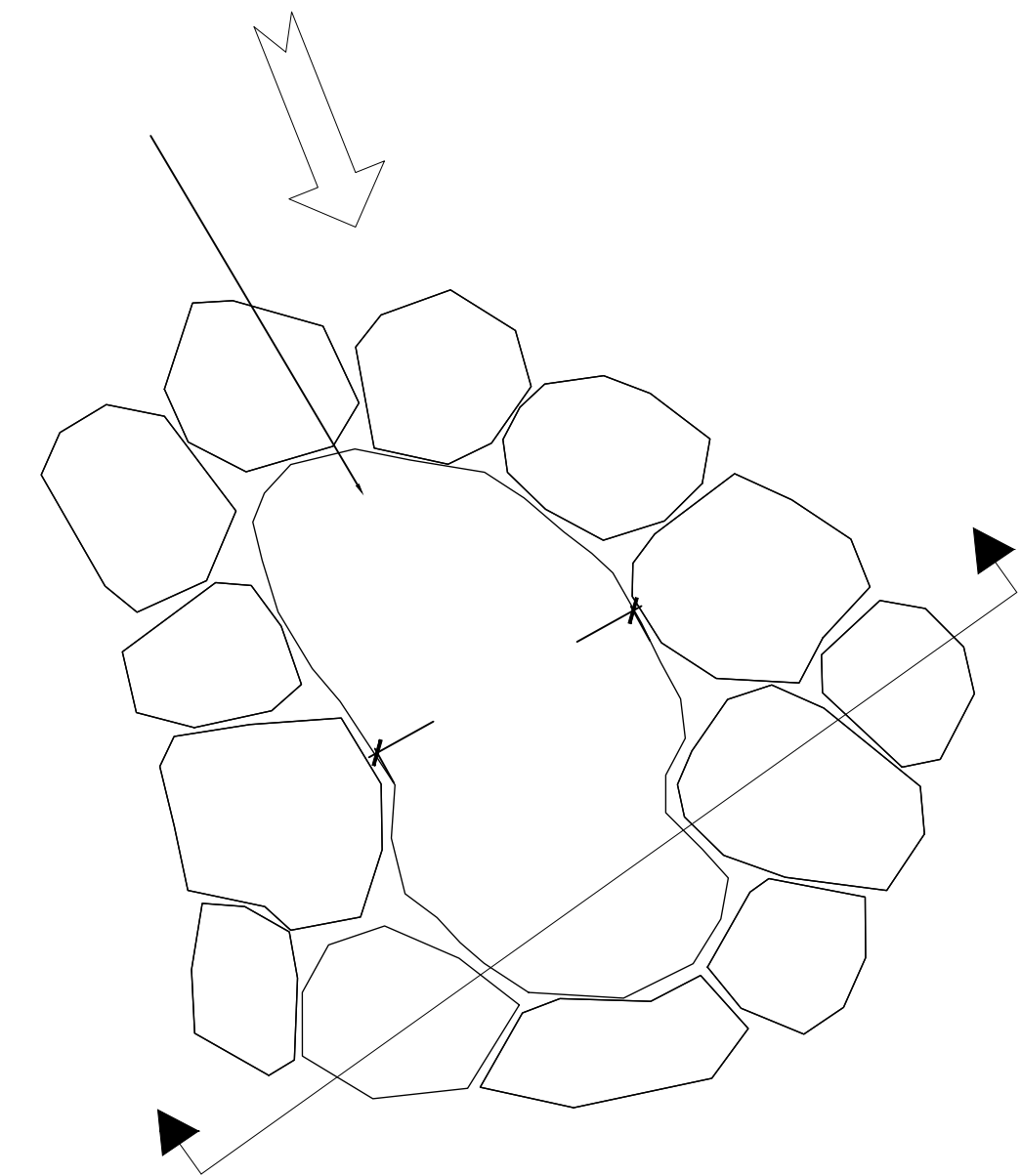
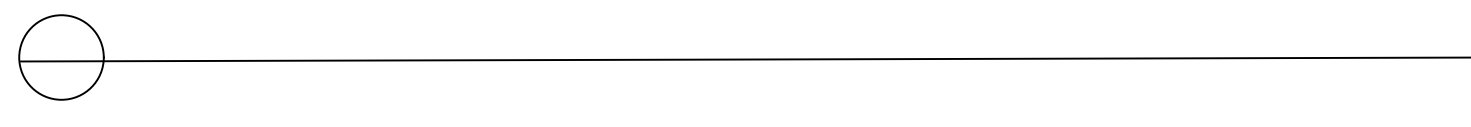
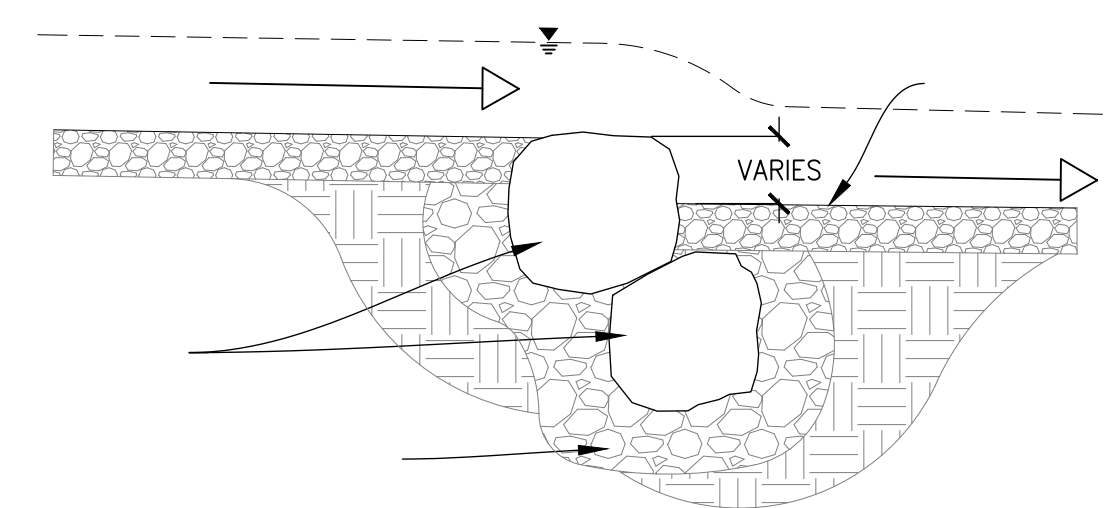
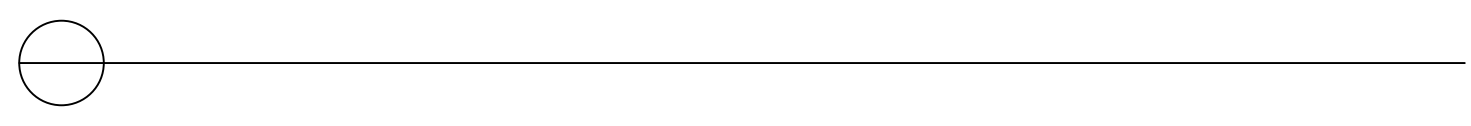
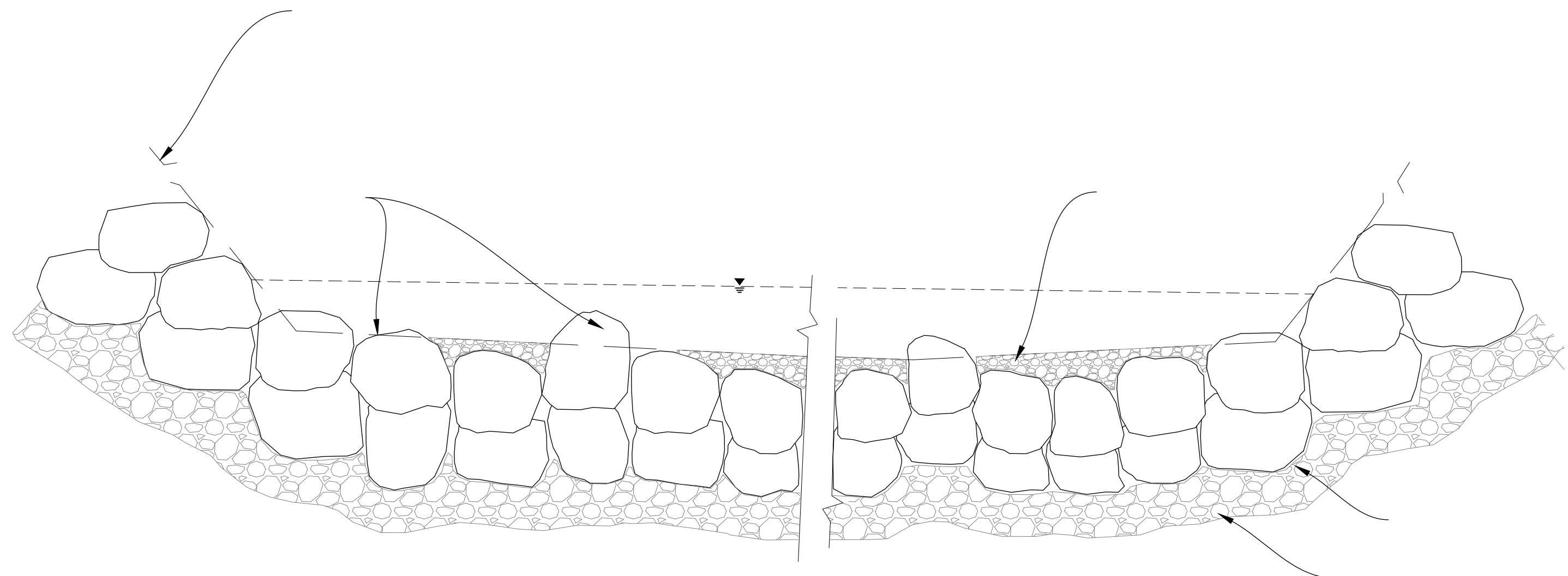

ARMORING AROUND IN-STREAM BOULDER(S) (TYP.)

SCALE: 1:5

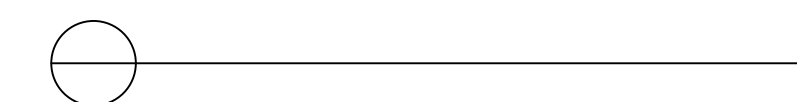
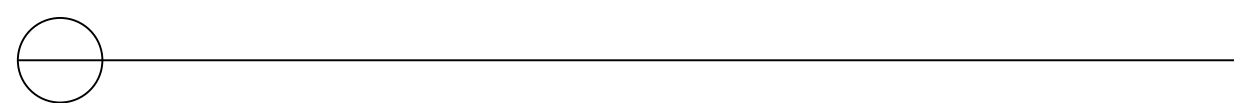
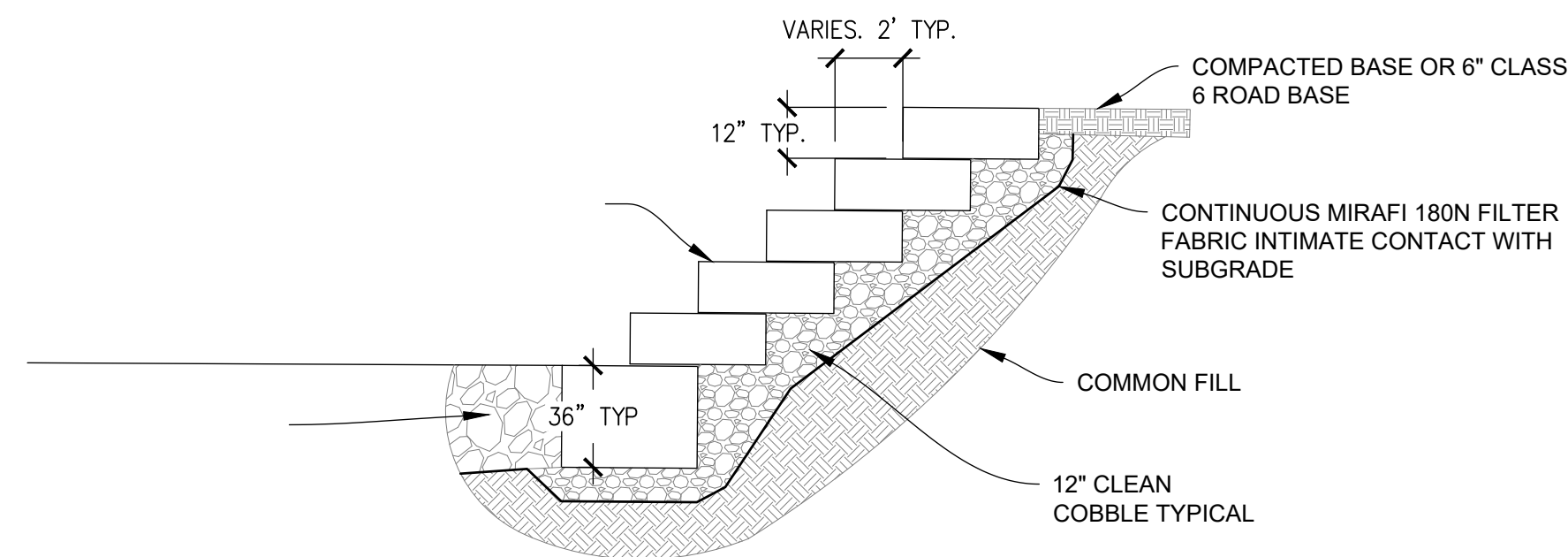
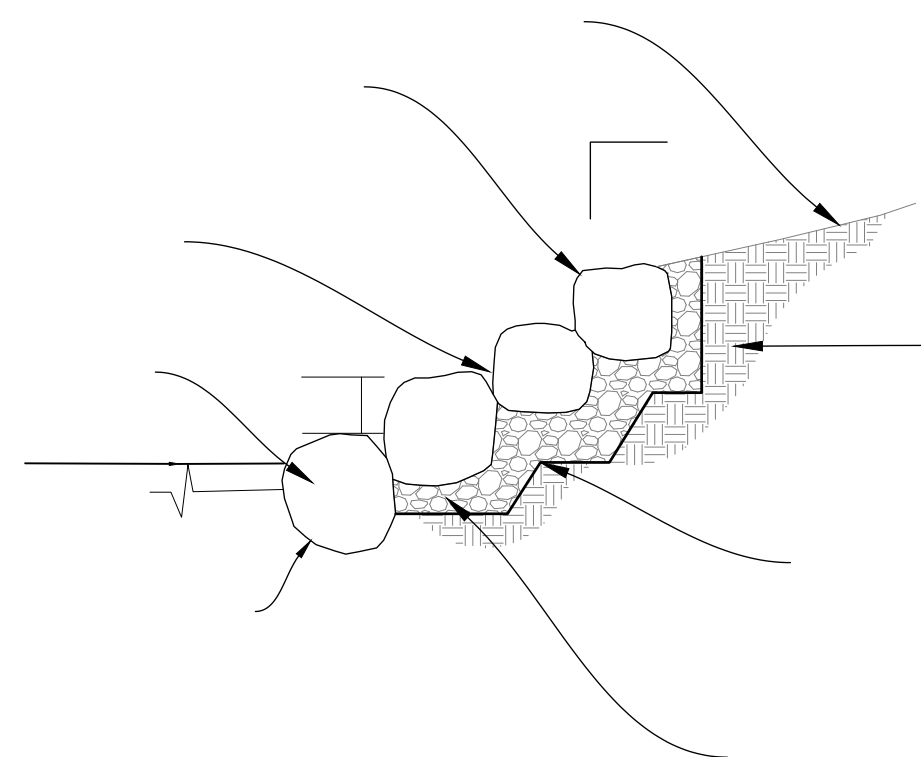
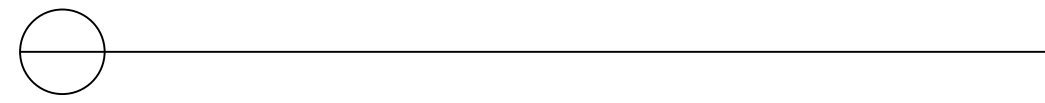
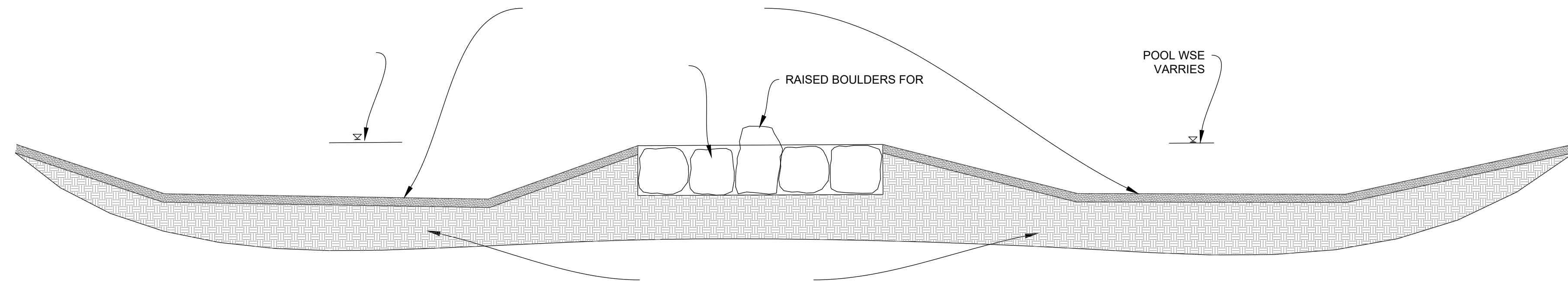
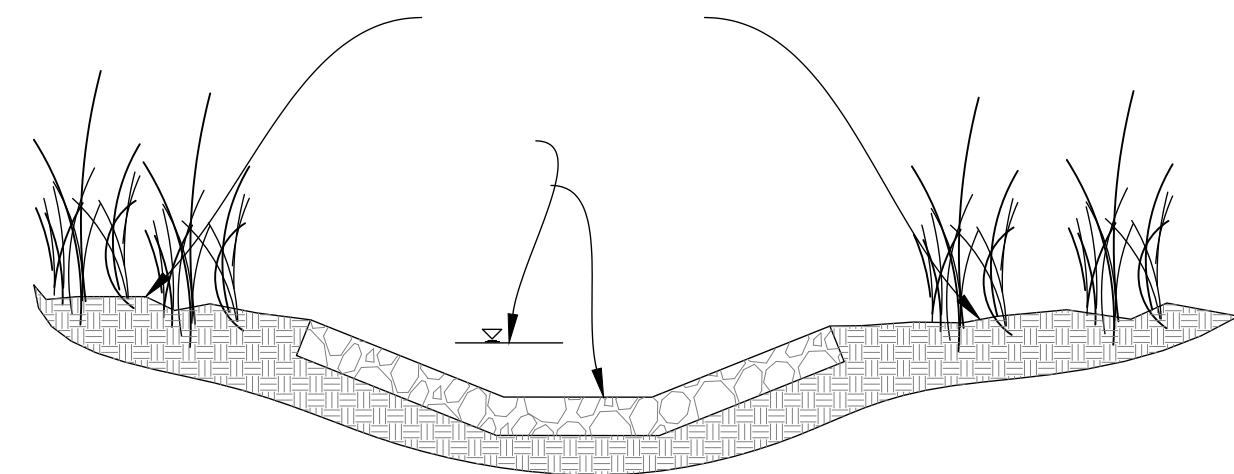
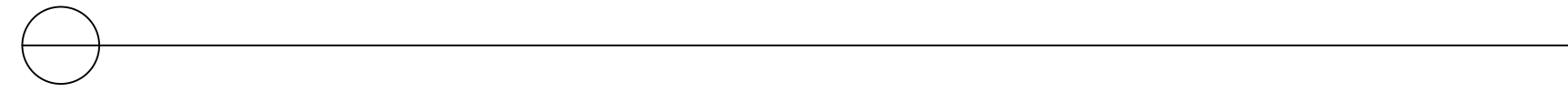
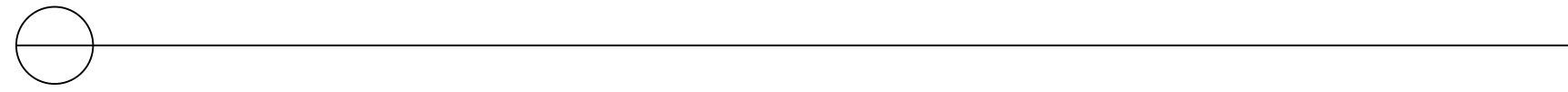
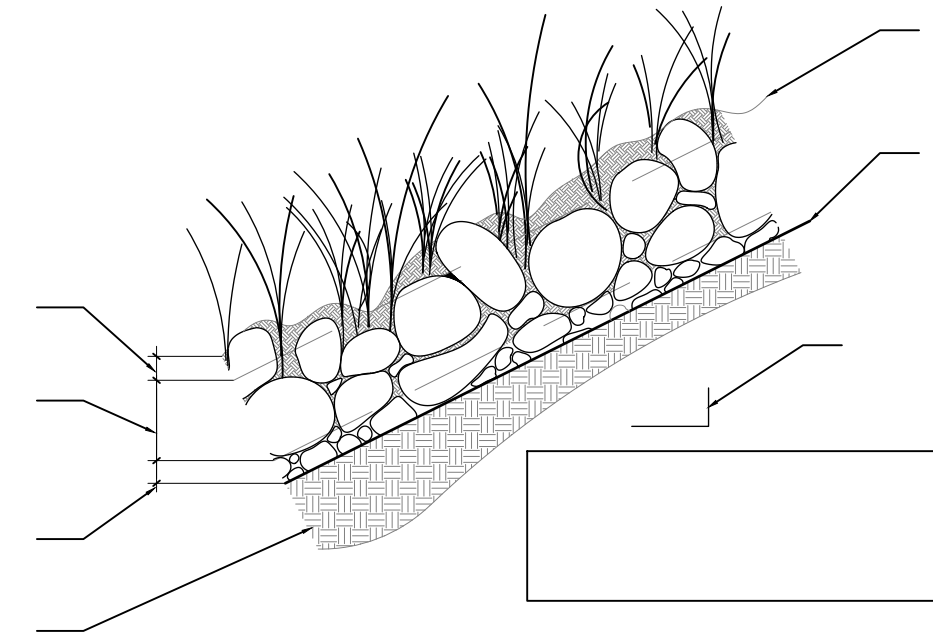
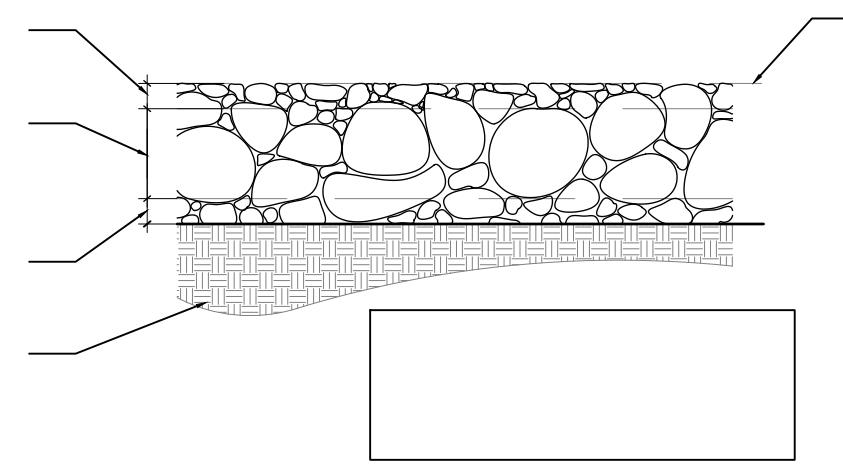

Status:
100% DESIGN DRAWINGS

Drawing Name:
TYPICAL DETAILS

Revisions:
--

Drawn By:
NATHAN WERNER, CHRISTINE CLARK
Checked By:
Scott Shipley

Date:
06/21/2021

Vertical Datum:
NVGD 29
ACOE Project:
NWW-2020-440-102

Stamp:

REUSE OF DOCUMENT:
THIS DOCUMENT IS THE PROPERTY OF ISO DESIGN AND ENGINEERING. THE IDEAS, DESIGN
AND CONTENT INCORPORATED ON THIS DOCUMENT IS AN INSTRUMENT OF PROFESSIONAL
SERVICE AND SHALL NOT BE USED FOR ANY OTHER PROJECT WITHOUT THE WRITTEN
AUTHORIZATION OF ISO DESIGN AND ENGINEERING.

Scale: Sheet:
WW-6.3
25 of 32

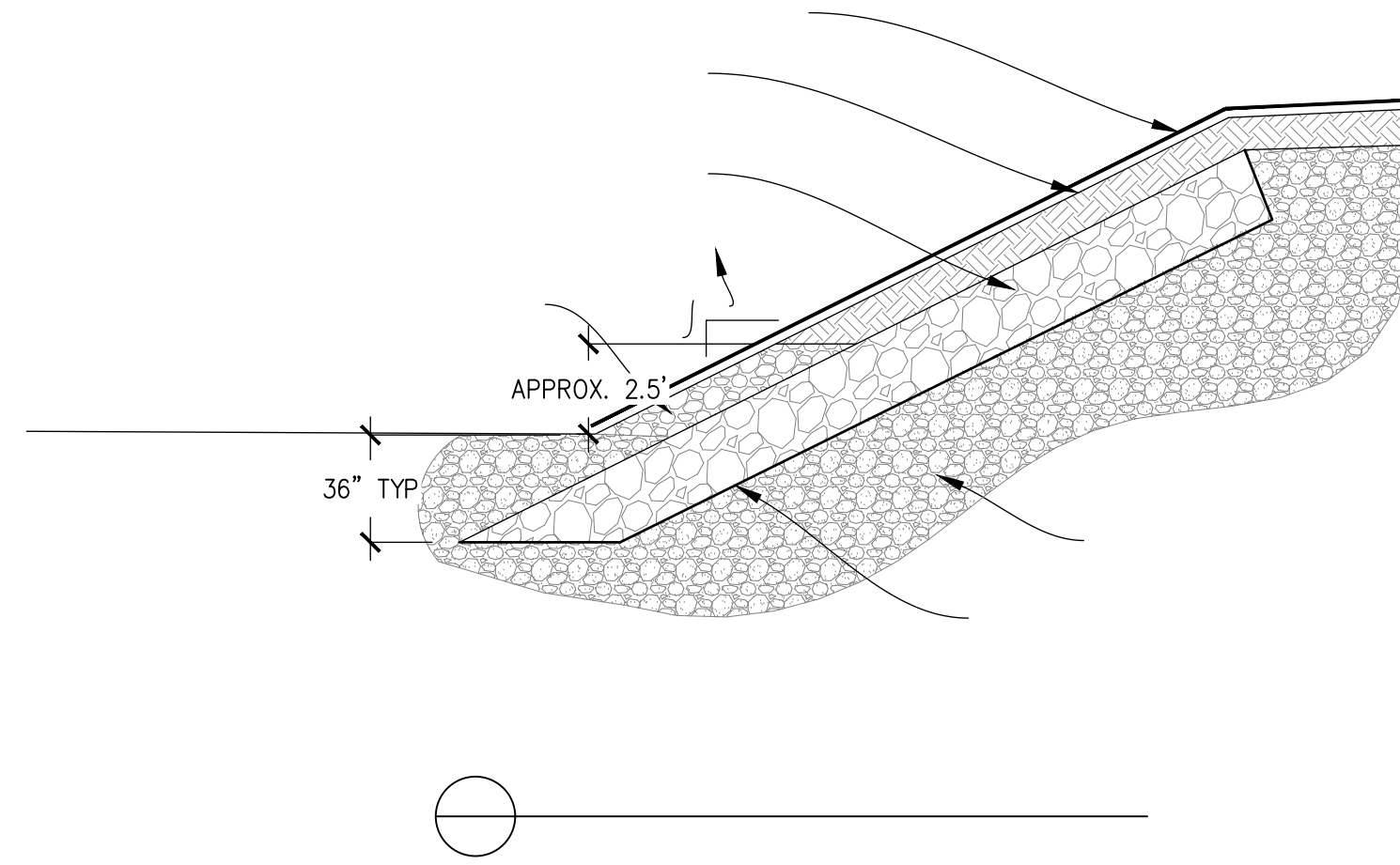
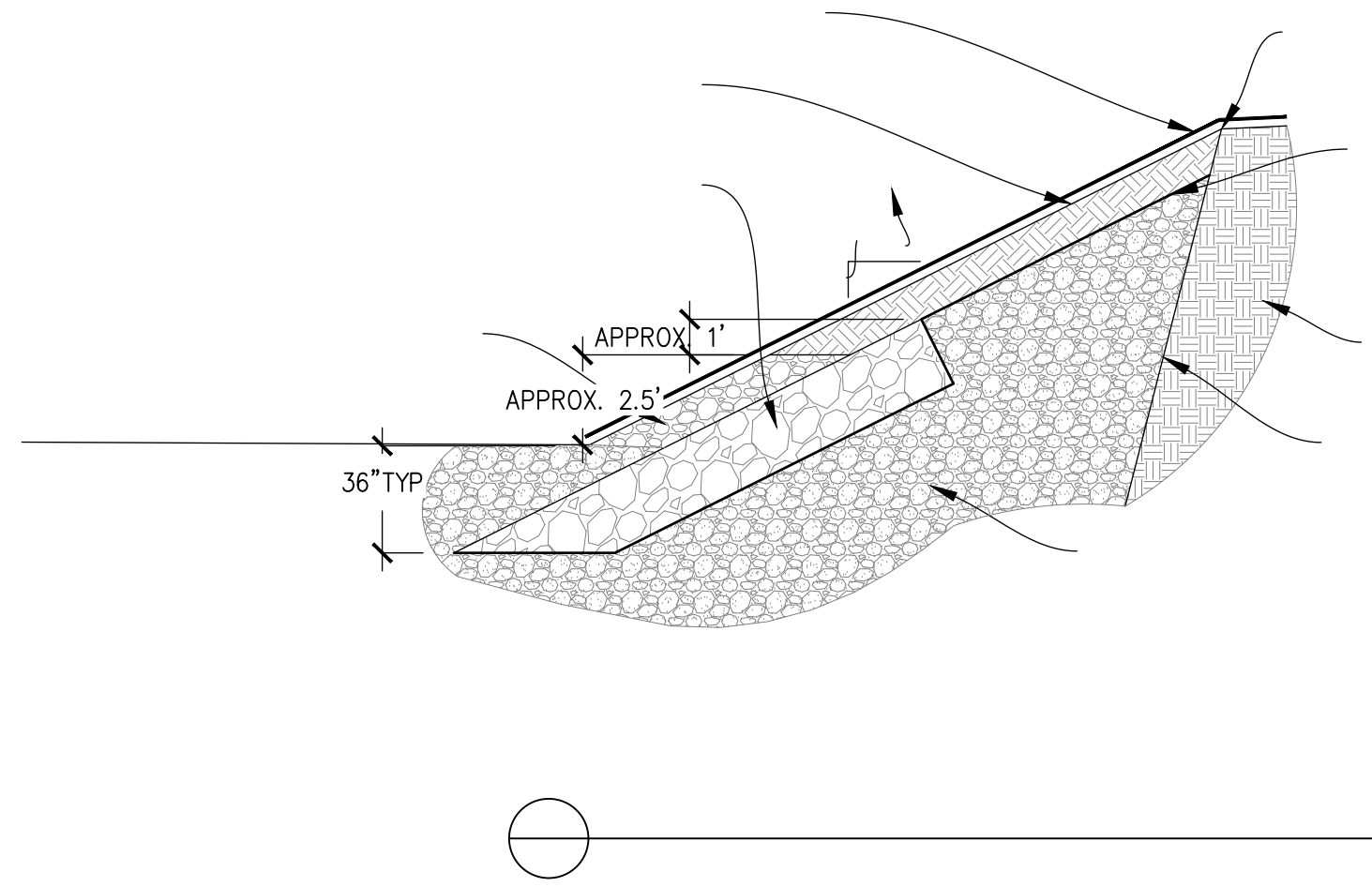

Status:
100% DESIGN DRAWINGS

Drawing Name:
TYPICAL DETAILS

Revisions:
--

Drawn By:
NATHAN WERNER, CHRISTINE CLARK
Checked By:
Scott Shipley

Date:
06/21/2021

Vertical Datum:
NVD 29
ACOE Project:
NWW-2020-440-I02

Stamp:

REUSE OF DOCUMENT:
THIS DOCUMENT IS THE PROPERTY OF ISO DESIGN AND ENGINEERING. THE IDEAS, DESIGN
AND CONTENT INCORPORATED ON THIS DOCUMENT IS AN INSTRUMENT OF PROFESSIONAL
SERVICE AND SHALL NOT BE USED FOR ANY OTHER PROJECT WITHOUT THE WRITTEN
AUTHORIZATION OF ISO DESIGN AND ENGINEERING.

Scale: Sheet:
WW-6.4
26 of 32

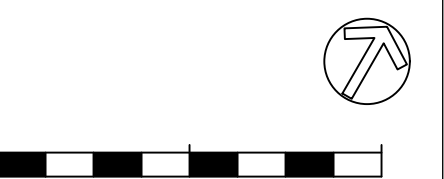
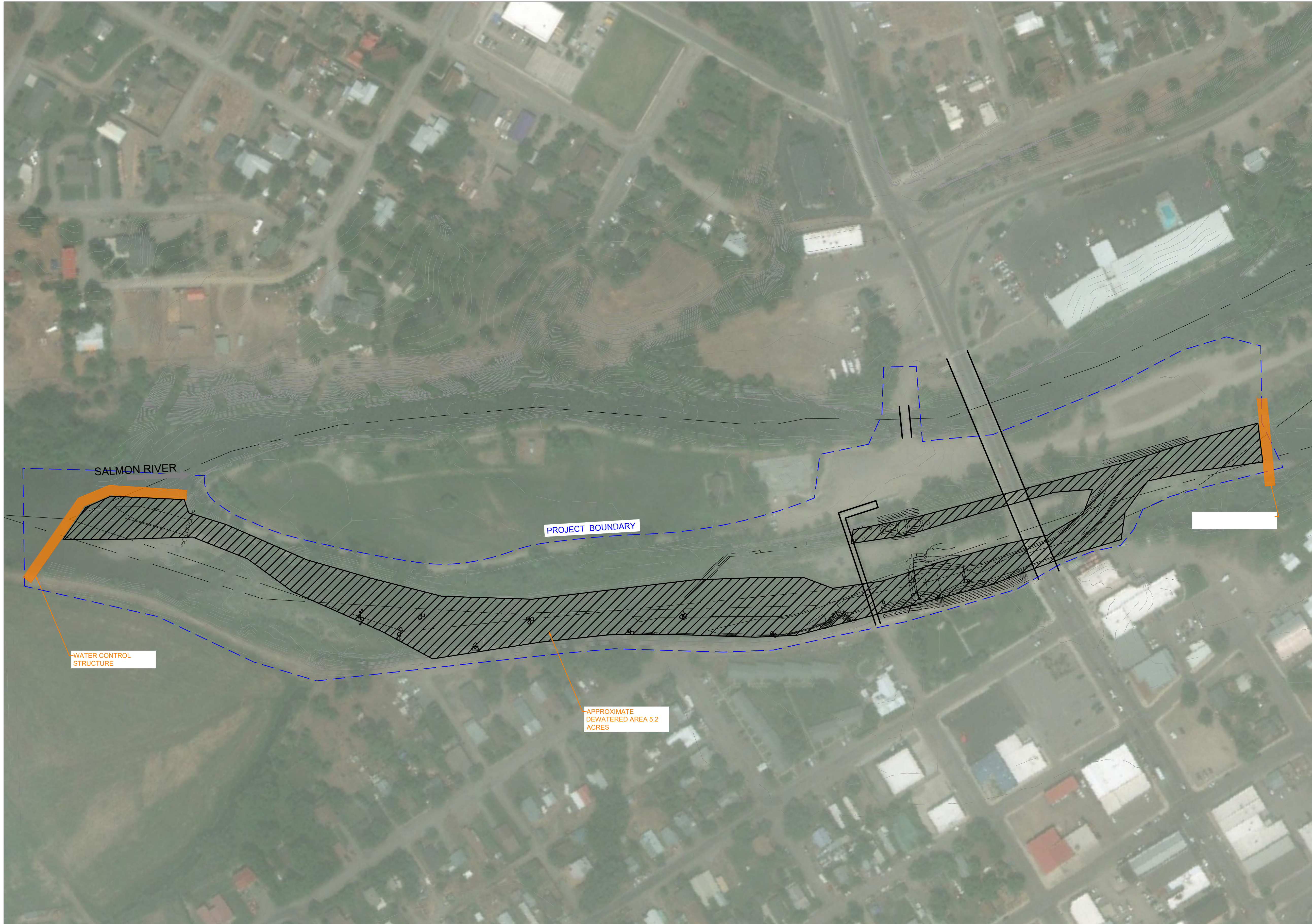

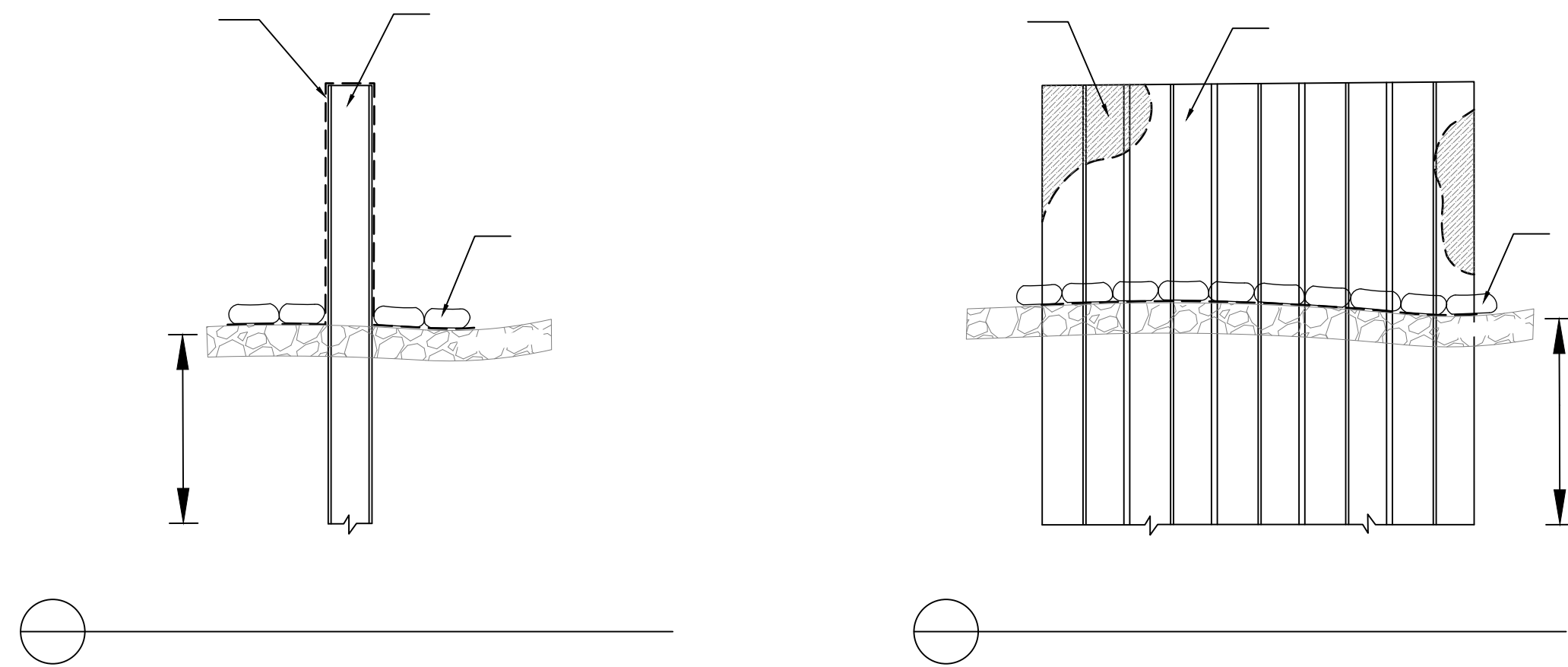
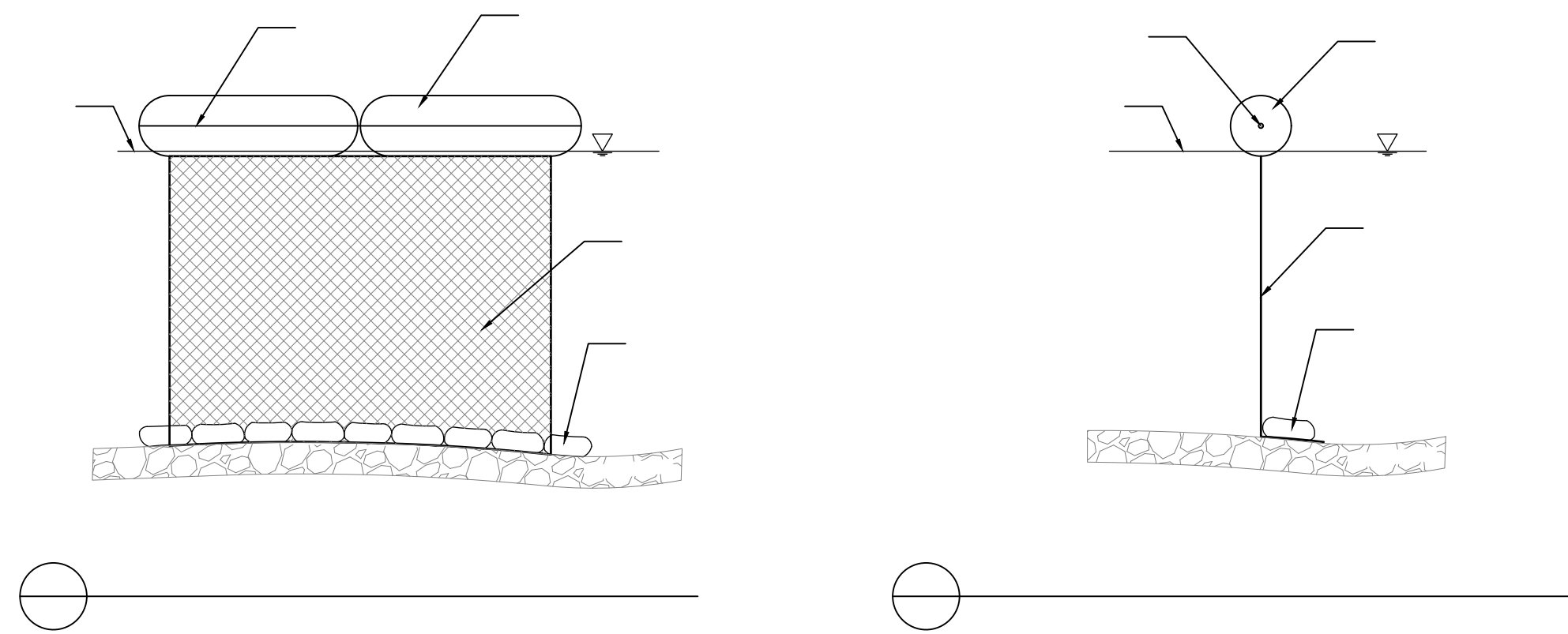

THE IMPLEMENTATION OF EROSION AND SEDIMENT CONTROL MEASURES AND BEST MANAGEMENT PRACTICES INCLUDING CONSTRUCTION, MAINTENANCE, REPLACEMENT AND UPGRADING ARE THE RESPONSIBILITY OF THE CONTRACTOR UNTIL ALL CONSTRUCTION IS COMPLETED AND APPROVED.

THE DETAILS SHOWN ON THIS SHEET ARE AN EXAMPLE OF ACCEPTABLE METHODS TO USE DURING CONSTRUCTION OF THIS PROJECT. THE CONTRACTOR IS RESPONSIBLE FOR DEVELOPING AND SUBMITTING A COFFERDAM PLAN TO INCLUDE SUFFICIENT DETAIL OF MEANS AND METHODS SATISFACTORILY MEETING THE PROJECT SPECIFICATIONS AND PERMIT REQUIREMENTS. COFFERDAMS MAY CONSIST OF OTHER METHODS INCLUDING (BUT NOT LIMITED TO) SECLUSION FENCING, SAND BAGS, BULK BAGS, SUPER SACKS, SHEET PILE AND INFLATABLE BLADDERS. COFFERDAMS SHALL INCLUDE PLASTING LINER OR FINE MESH SILT FENCE TO REDUCE TURBIDITY AND FINES FROM ENTERING THE FREE FLOWING PORTION OF LIVE

ALL PUMP INTAKES SHALL BE SCREENED FOR FISH PROTECTION AS REQUIRED BY REGULATORY AGENCIES. DEWATERING PUMP DISCHARGE FROM WITHIN COFFERDAM WORK AREAS SHALL BE RELEASED ONTO FLOODPLAIN AREAS AWAY FROM WETLANDS AND CONSTRUCTION ACTIVITIES. DISCHARGE SHALL NOT CAUSE EROSION OF TOPSOIL AND SHALL SHEET FLOW OVER THE FLOODPLAIN BEFORE RETURNING TO LIVE WATER DOWNSTREAM OF THE WORK AREA. ALL RETURN FLOWS MUST MEET PERMIT REQUIREMENTS FOR TURBIDITY. ALL EARTHWORK AND WOOD STRUCTURES CONSTRUCTION WITHIN THE ORDINARY HIGH CHANNEL SHALL CONFORM TO WATER QUALITY STANDARDS ESTABLISHED BY THE REGULATORY AGENCY PERMITS FOR THIS PROJECT.

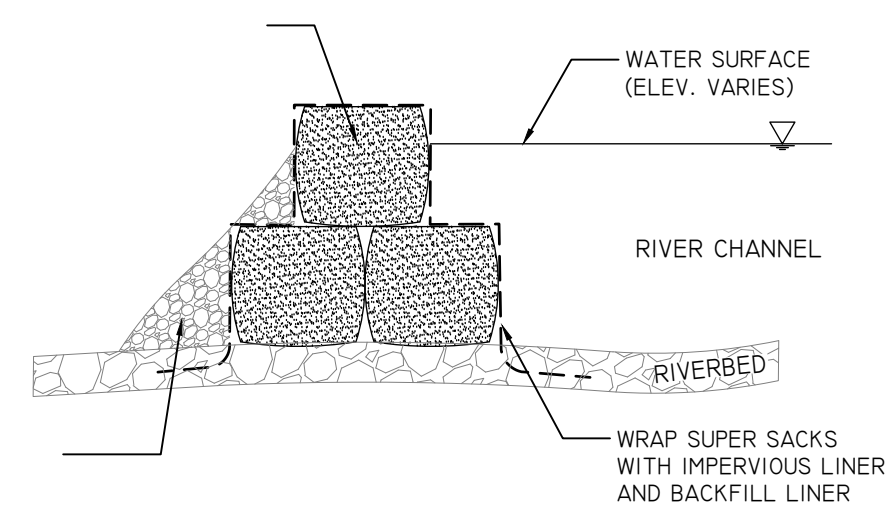
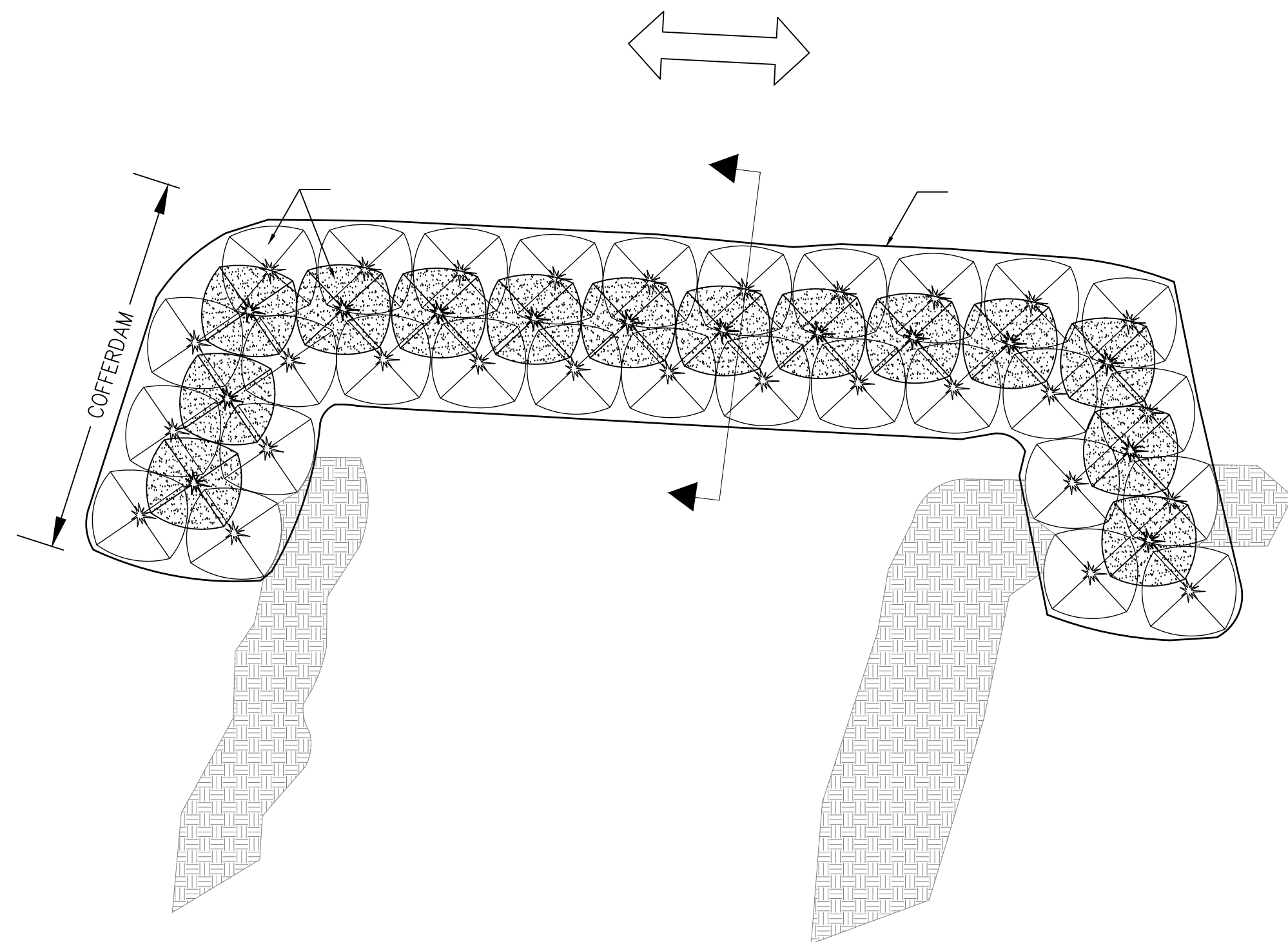

"SUPER SACK" COFFERDAM DOUBLE STACK
SCALE: NTS

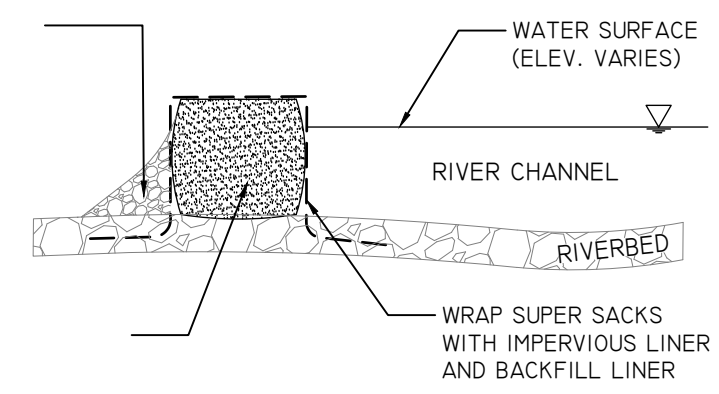

"SUPER SACK" COFFERDAM SINGLE STACK
SCALE: NTS

Status:
100% DESIGN DRAWINGS

Drawing Name:
TYPICAL DEWATERING DETAILS

Revisions:
--

Drawn By:
NATHAN WERNER, CHRISTINE CLARK
Checked By:
Scott Shipley

Date:
06/21/2021

Vertical Datum:
NVGD 29
ACOE Project:
NWW-2020-440-I02

Stamp:

REUSE OF DOCUMENT:
THIS DOCUMENT IS THE PROPERTY OF ISO DESIGN AND ENGINEERING. THE IDEAS, DESIGN AND CONTENT INCORPORATED ON THIS DOCUMENT IS AN INSTRUMENT OF PROFESSIONAL SERVICE AND SHALL NOT BE USED FOR ANY OTHER PROJECT WITHOUT THE WRITTEN AUTHORIZATION OF ISO DESIGN AND ENGINEERING.

Scale: Sheet:
WW-7.1
28 of 32

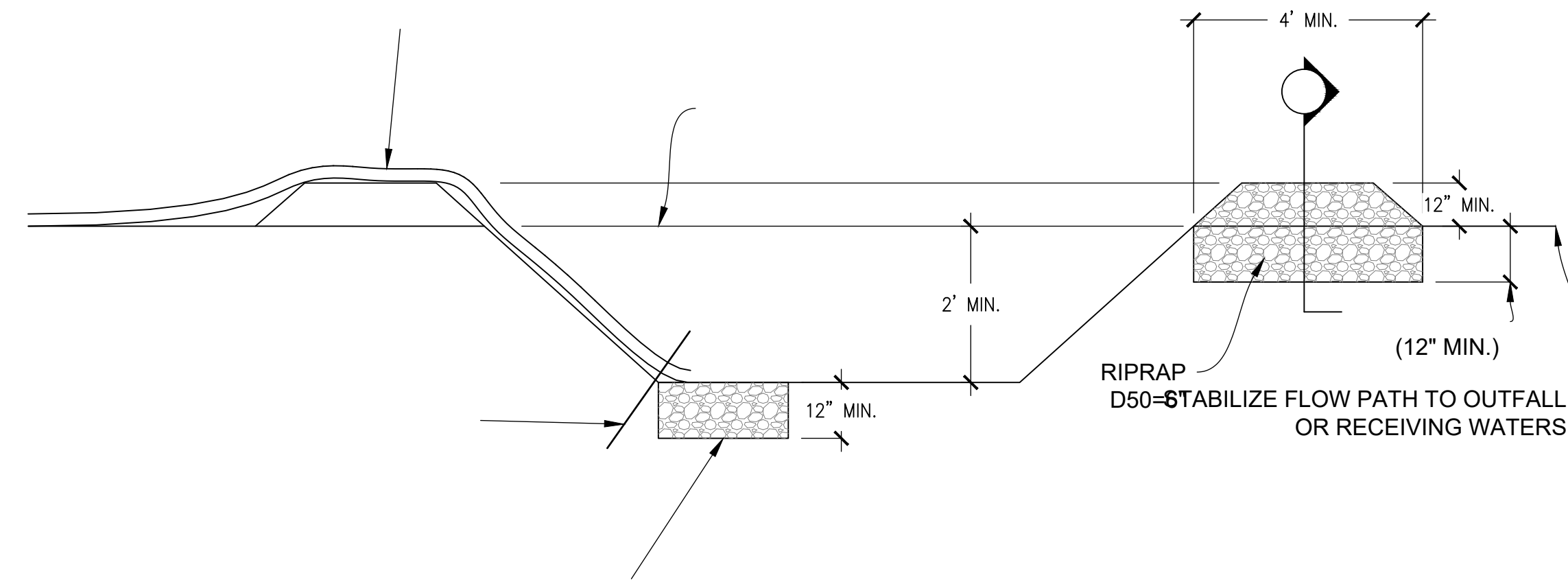
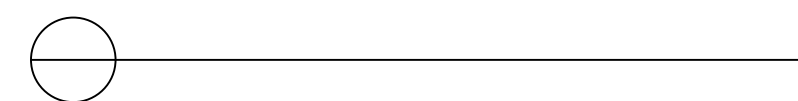
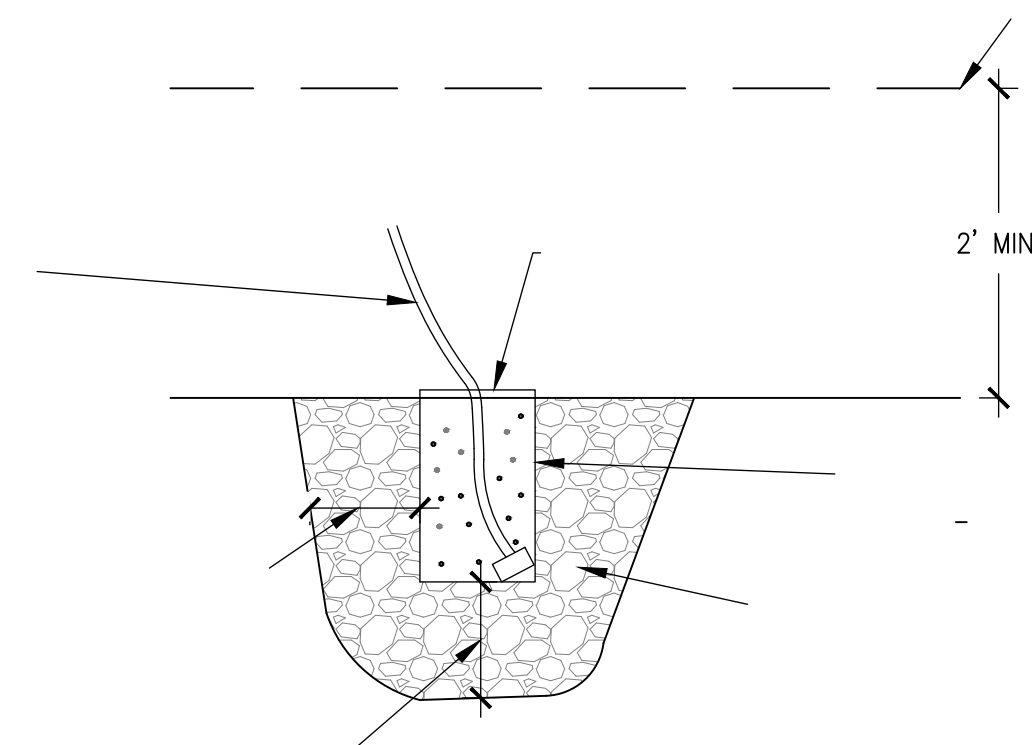
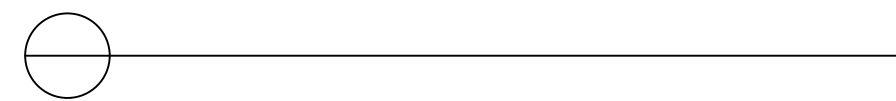
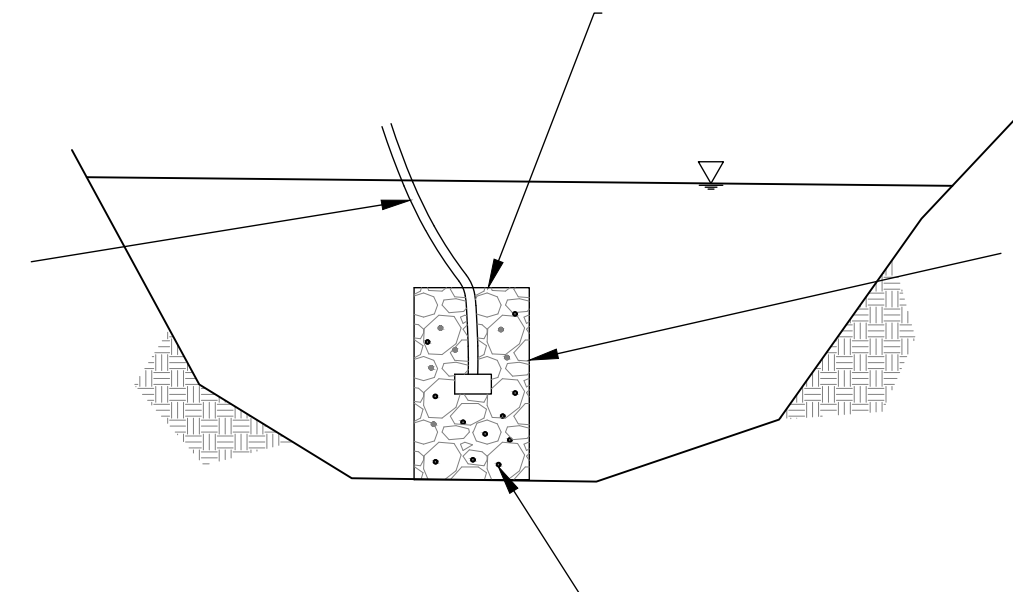

SUMP DISCHARGE SETTLING BASIN SECTION NTS

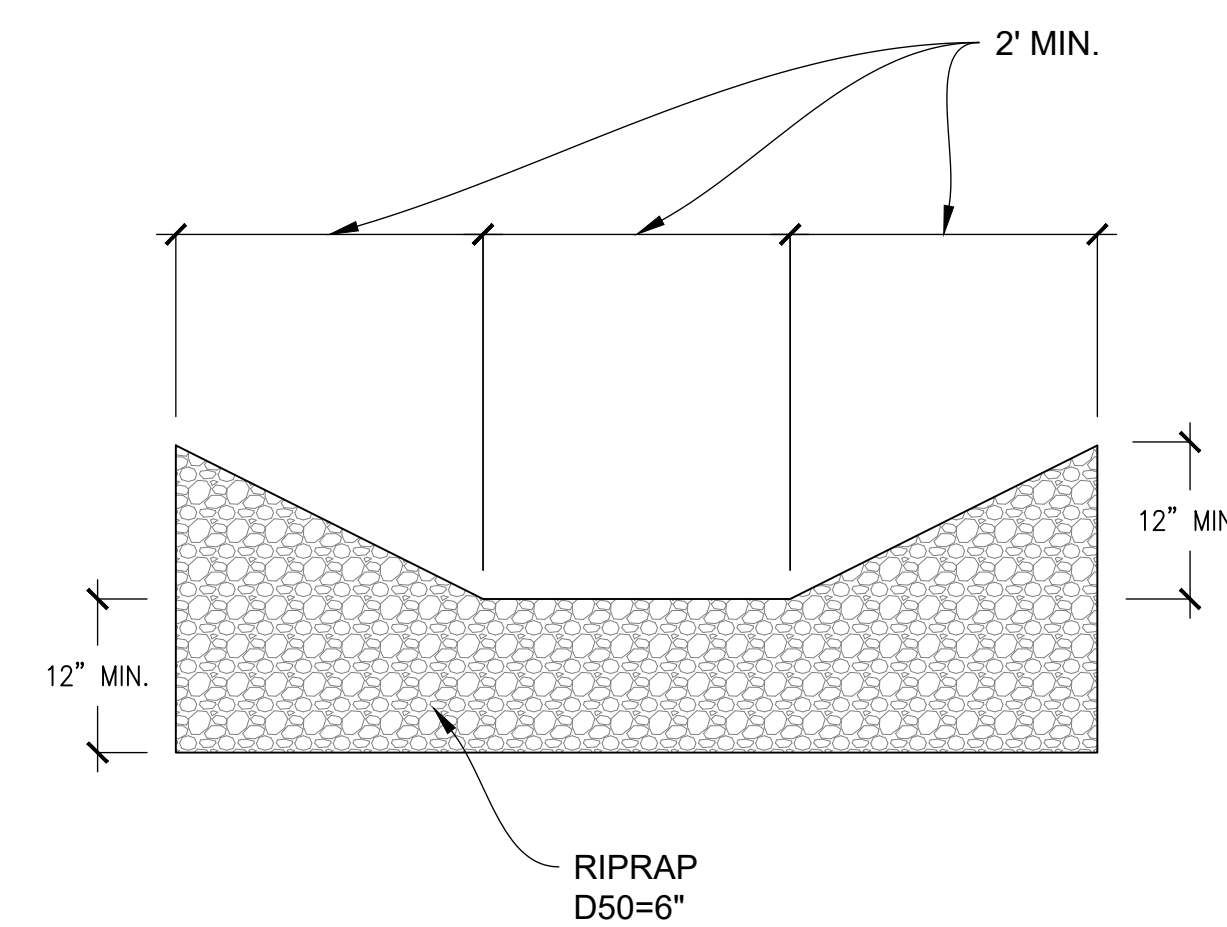

SETTLING BASIN SECTION NTS

Status:
100% DESIGN DRAWINGS

Drawing Name:
TYPICAL DEWATERING DETAILS

Revisions:
--

Drawn By:
NATHAN WERNER, CHRISTINE CLARK
Checked By:
Scott Shipley

Date:
06/21/2021

Vertical Datum:
NVD 29
ACOE Project:
NWW-2020-440-I02

Stamp:

REUSE OF DOCUMENT:
THIS DOCUMENT IS THE PROPERTY OF ISO DESIGN AND ENGINEERING. THE IDEAS, DESIGN
AND CONTENT INCORPORATED ON THIS DOCUMENT IS AN INSTRUMENT OF PROFESSIONAL
SERVICE AND SHALL NOT BE USED FOR ANY OTHER PROJECT WITHOUT THE WRITTEN
AUTHORIZATION OF ISO DESIGN AND ENGINEERING.

Scale:

Sheet:
WW-7.2
29 of 32

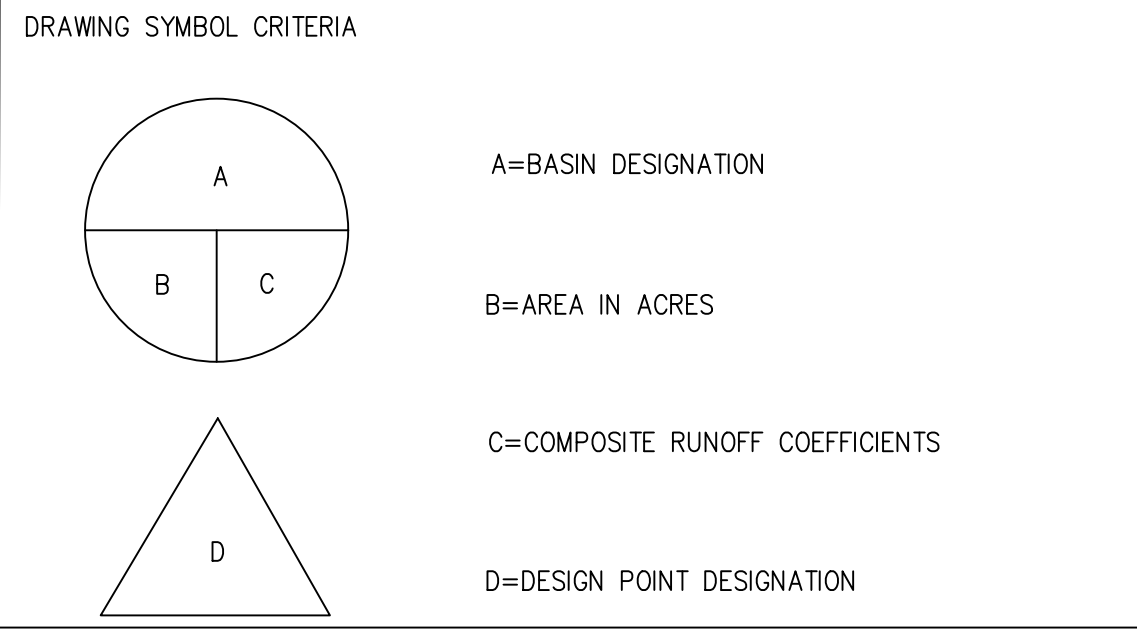

NATIVE SOIL:	BEDDING:
COARSE GRAINED SAND AND GRAVEL (50% OR MORE BY WEIGHT RETAINED ON # 40 SIEVE)	CDOT CLASS A FILTER MATERIAL (SECTION 703.04)
FINE GRAINED SOIL (LESS THAN 50% RETAINED ON # 40 SIEVE)	UDFCD TYPE 1 FILTER MATERIAL CDOT FINE AGGREGATE FOR CONCRETE AASHTO M6 (SECTION 703.01)

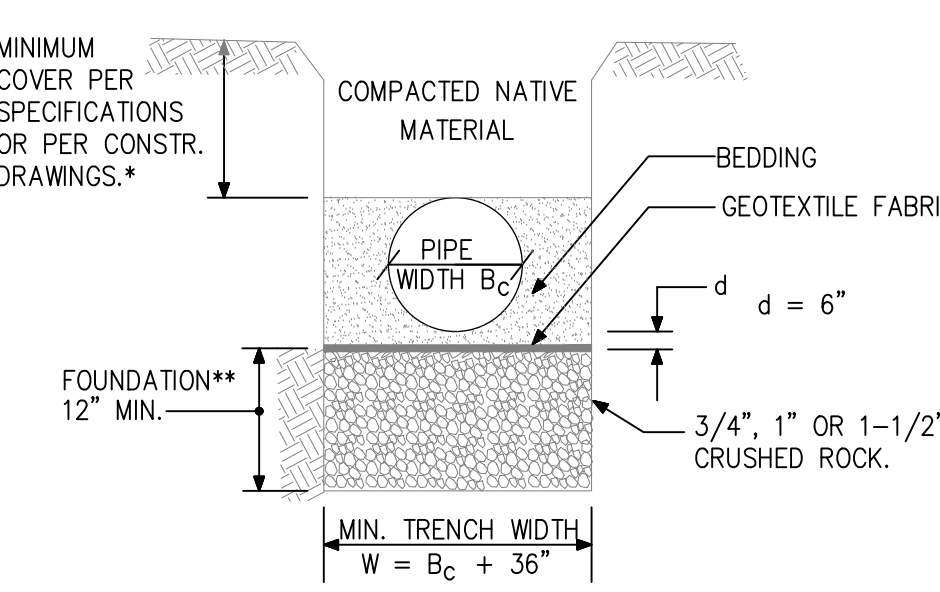
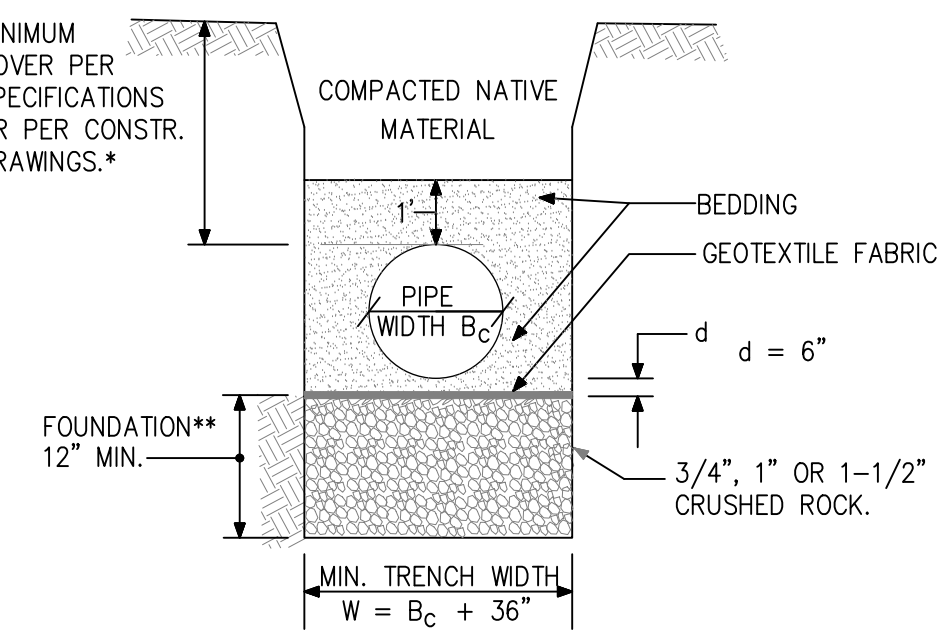
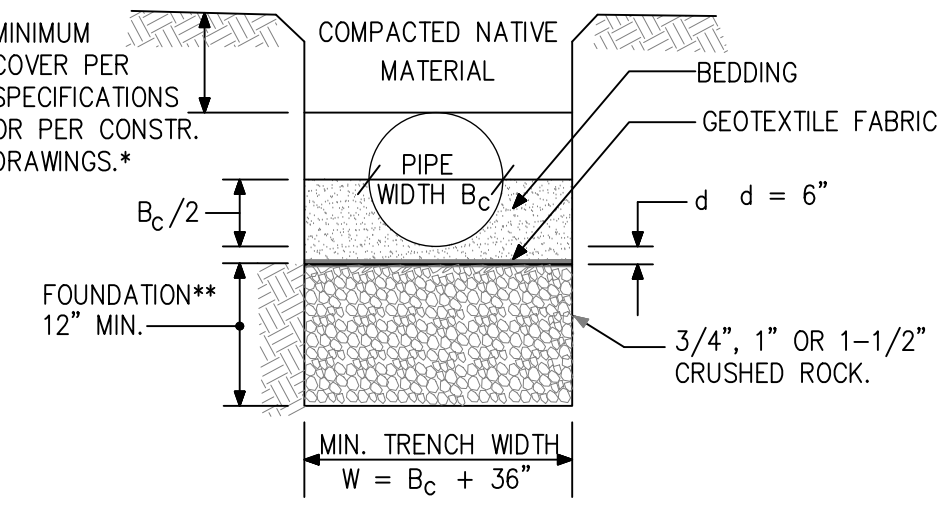

* MINIMUM COVER SHALL NOT INCLUDE PAVEMENT.
 ** MAY BE REQUIRED IN AREAS WITH HIGH GROUNDWATER TABLE OR UNSUITABLE SUB-GRADE.

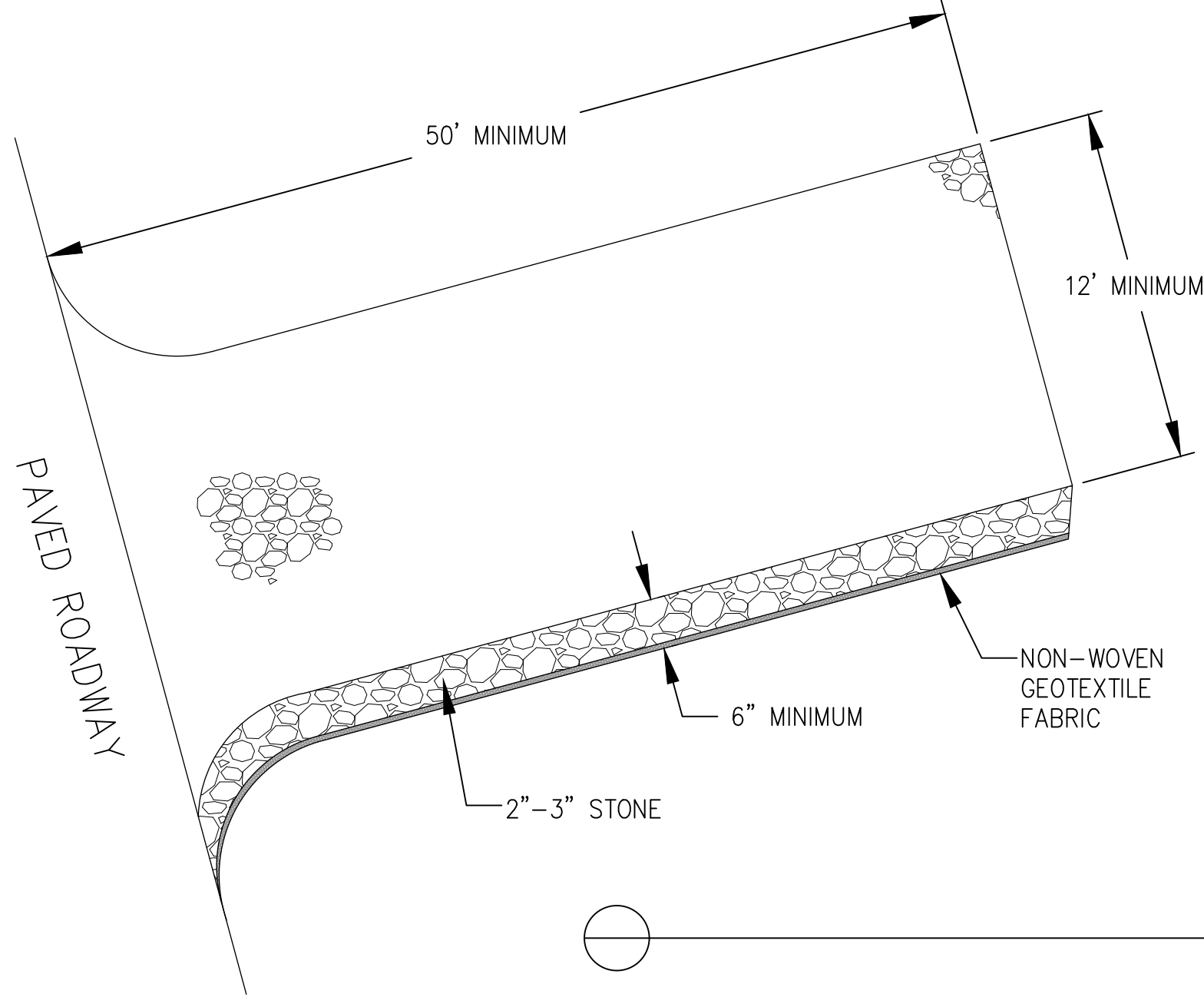

- NOTES:**
- PAVED ROADWAY TO BE KEPT CLEAN OF MUD, DIRT, ROCKS, AND DEBRIS AT ALL TIMES.
 - GEOTEXTILE FABRIC SHALL COMPLY WITH CDOT 712.08b.
 - 2"-3" STONE SHALL CONTAIN LESS THAN 10% FINES.
 - CONSTRUCTION EXIT SHALL BE MAINTAINED AT ALL TIMES. STONE SHOULD BE BLADED AND/OR ADDITIONAL 2"-3" STONE SHOULD BE PLACED IF VOIDS BEGIN FILLING WITH DEBRIS.
 - IF A DRAINAGE DITCH EXISTS NEXT TO ROADWAY, INSTALL TEMPORARY CULVERT UNDERNEATH STONE CONSTRUCTION EXIT TO CONVEY FLOW.
 - PROVIDE INLET PROTECTION FOR ANY INLETS LOCATED IMMEDIATELY ADJACENT TO THE CONSTRUCTION EXIT.
 - IF TRACKOUT DOES OCCUR, ROADWAY SHOULD BE SWEEP IMMEDIATELY.
 - RECYCLED CONCRETE OR RECYCLED ASPHALT SHALL NOT BE USED.

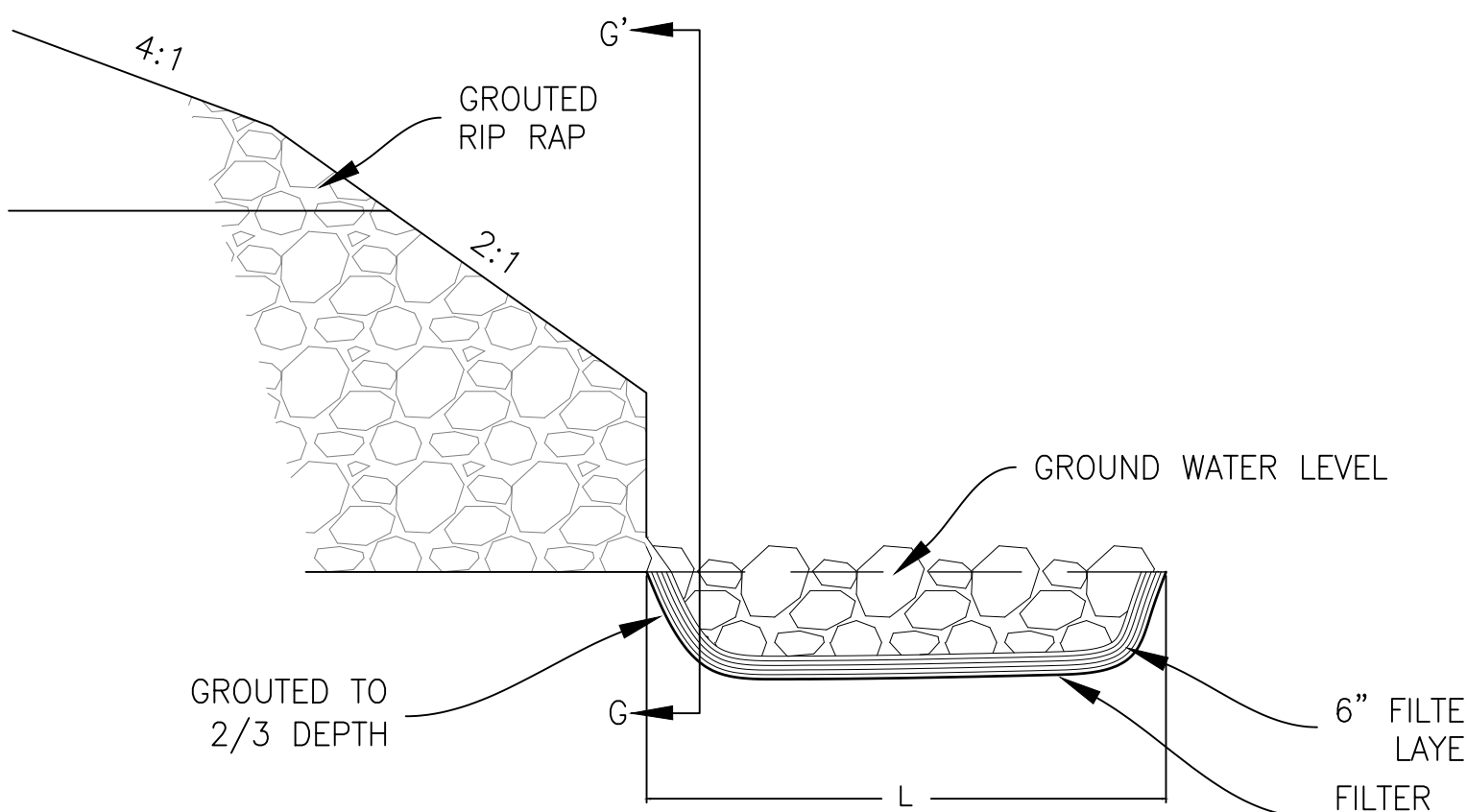

- NOTES:**
- L, D, AND W DIMENSIONS TO BE PROVIDED BY THE ENGINEER OF RECORD
 - RIP RAP SHALL BE HAND PLACED
 - SEE SPECIFICATIONS FOR MATERIALS
 - FILTER LAYER AND FABRIC ARE INCIDENTAL TO RIP RAP
 - ADD RIP RAP OVER TOP OF PIPE
 - PIPE SHALL BE RCP TO FIRST STRUCTURE

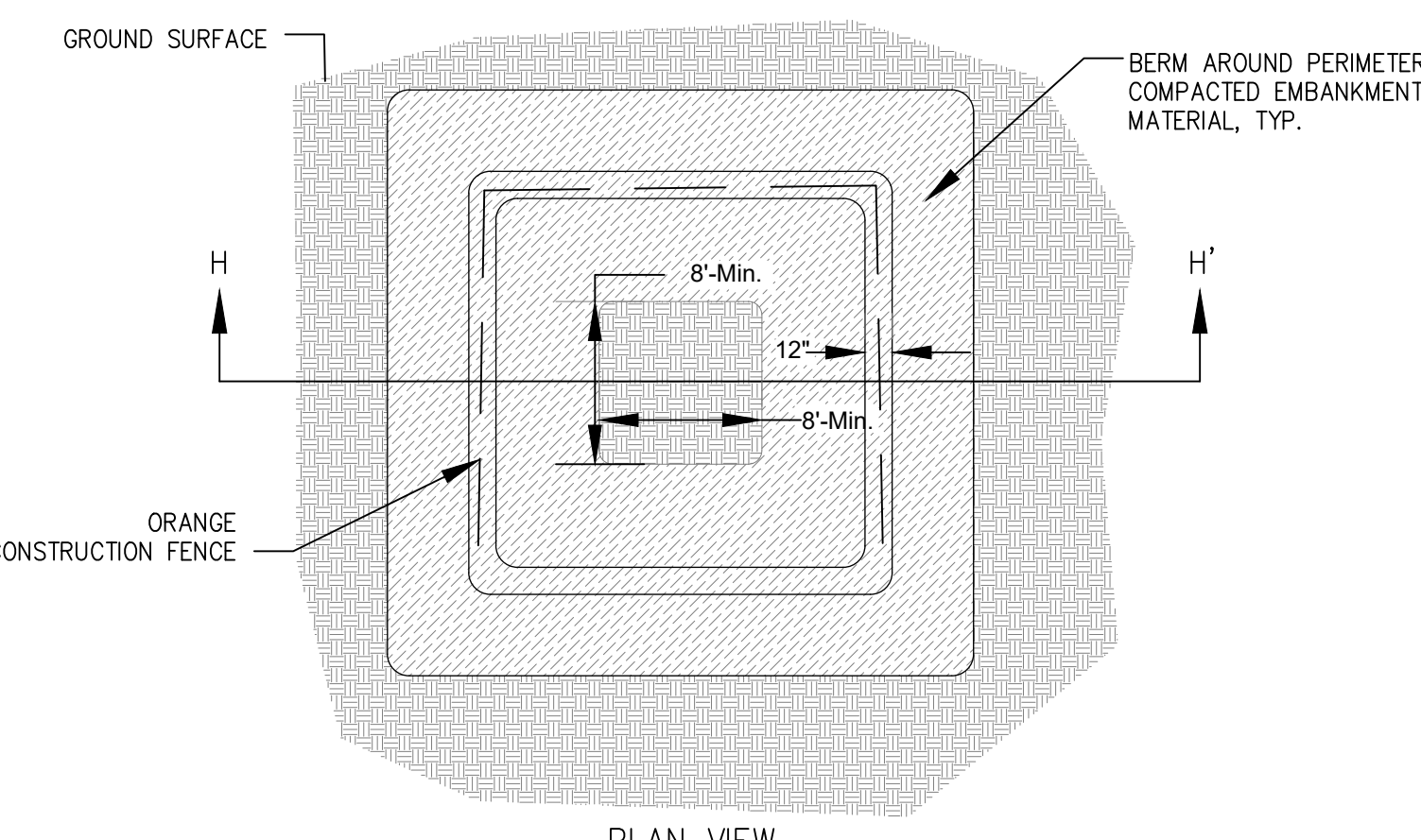
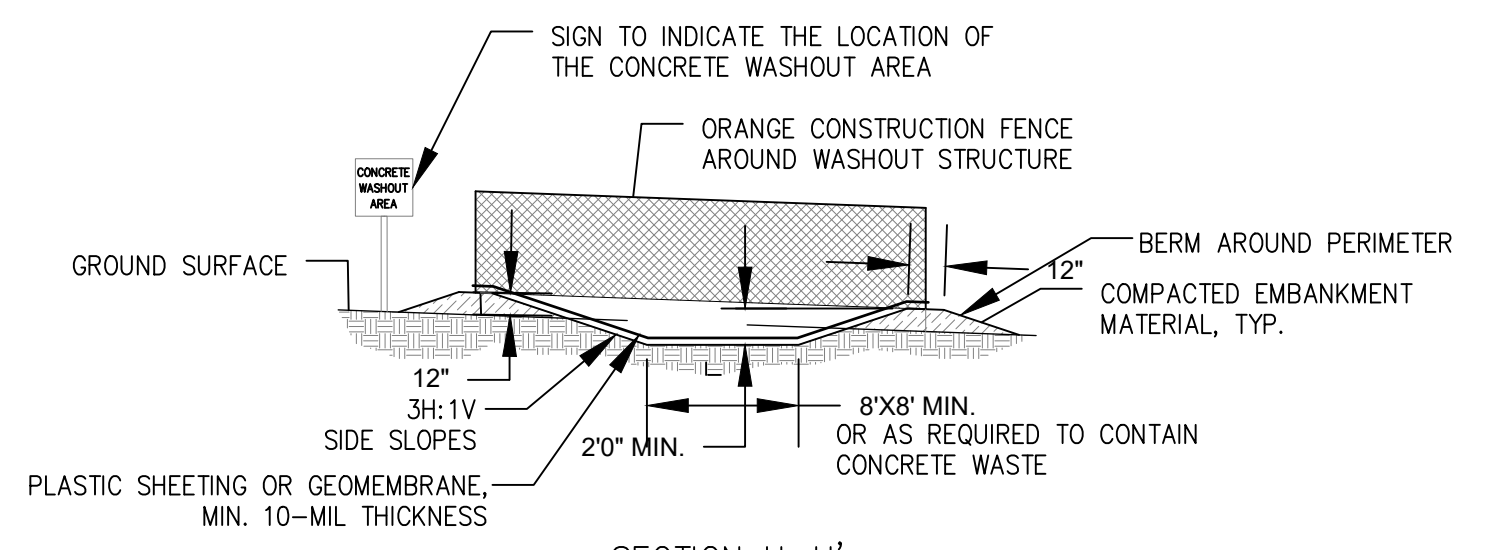
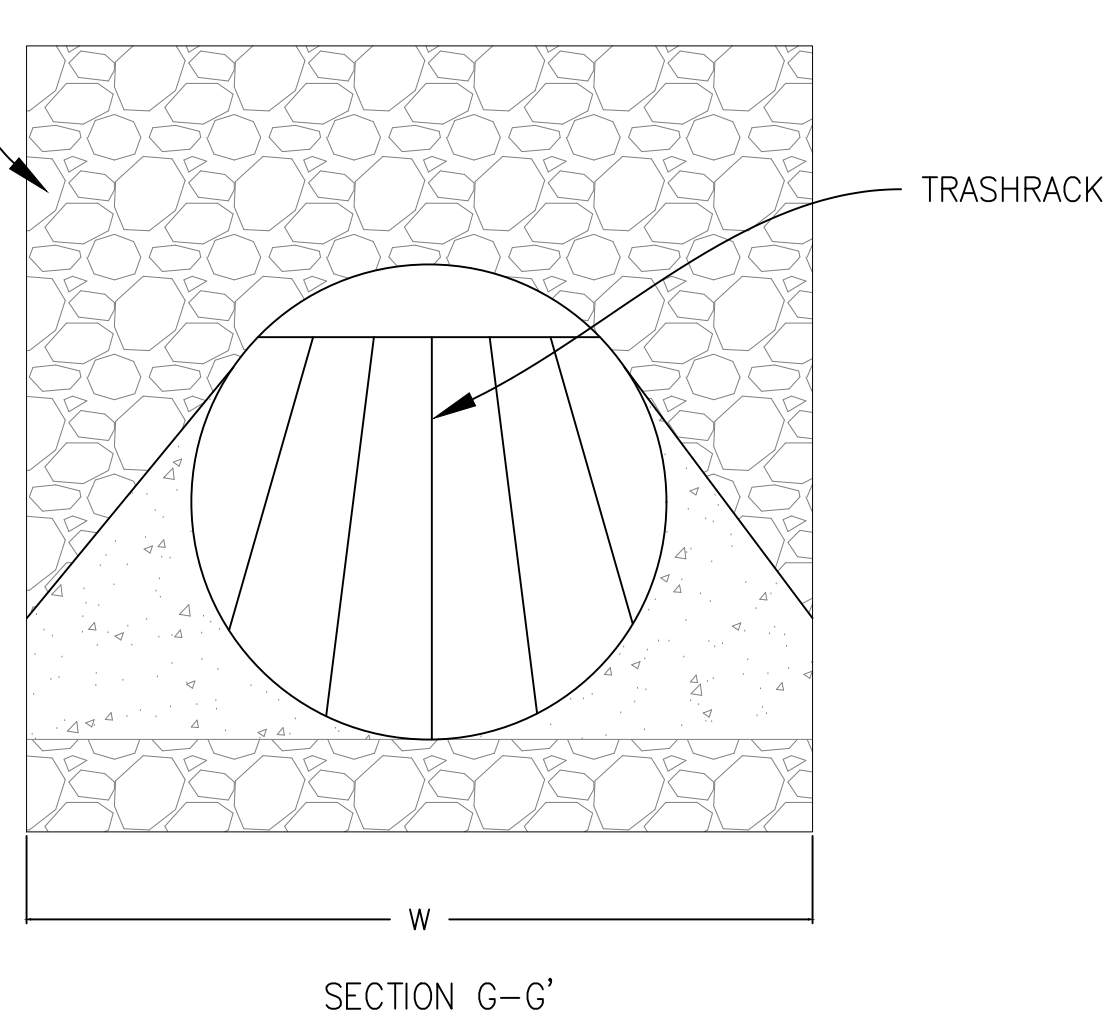

- NOTES:**
- CONCRETE WASHOUT AREA SHALL BE INSTALLED PRIOR TO ANY CONCRETE PLACEMENT ON SITE; PLACED A MINIMUM 50' FROM STATE WATERS.
 - VEHICLE TRACKING CONTROL IS REQUIRED AT CONCRETE WASHOUT ENTRANCE IF ACCESS TO CONCRETE WASHOUT AREA IS OFF PAVEMENT.
 - A PLASTIC SHEETING OR GEOMEMBRANE LINER SHALL BE PLACED. MINIMUM 10-MIL THICKNESS.
 - THE CONCRETE WASHOUT AREA SHALL BE REPAIRED AND/OR ENLARGED AS NECESSARY TO MAINTAIN CAPACITY FOR WASTE CONCRETE.
 - WASTE MATERIAL FROM CONCRETE WASHOUT OPERATIONS MUST BE REMOVED AND LEGALLY DISPOSED OF WHEN IT HAS ACCUMULATED TWO-THIRDS OF THE WET STORAGE CAPACITY OF THE STRUCTURE AND AT THE END OF CONSTRUCTION.
 - WHEN THE CONCRETE WASHOUT AREA IS REMOVED, THE DISTURBED AREA SHALL BE SEED AND MULCHED OR OTHERWISE STABILIZED IN A MANNER ACCEPTED BY THE CITY.
 - NO STORMWATER RUN-OFF SHALL DRAIN INTO CONCRETE WASHOUT AREA.

CONCRETE WASHOUT AREA DETAIL NTS

Status:
100% DESIGN DRAWINGS

Drawing Name:
TYPICAL BMP'S

Revisions:
--

Drawn By:
NATHAN WERNER, CHRISTINE CLARK

Checked By:
Scott Shipley

Date:
06/21/2021

Vertical Datum:
NVDG 29
ACOE Project:
NWW-2020-440-102

Stamp:

REUSE OF DOCUMENT:
THIS DOCUMENT IS THE PROPERTY OF ISO DESIGN AND ENGINEERING. THE IDEAS, DESIGN AND CONTENT INCORPORATED ON THIS DOCUMENT IS AN INSTRUMENT OF PROFESSIONAL SERVICE AND SHALL NOT BE USED FOR ANY OTHER PROJECT WITHOUT THE WRITTEN AUTHORIZATION OF ISO DESIGN AND ENGINEERING.

Scale:
Sheet:
WW-8.0
30 of 32

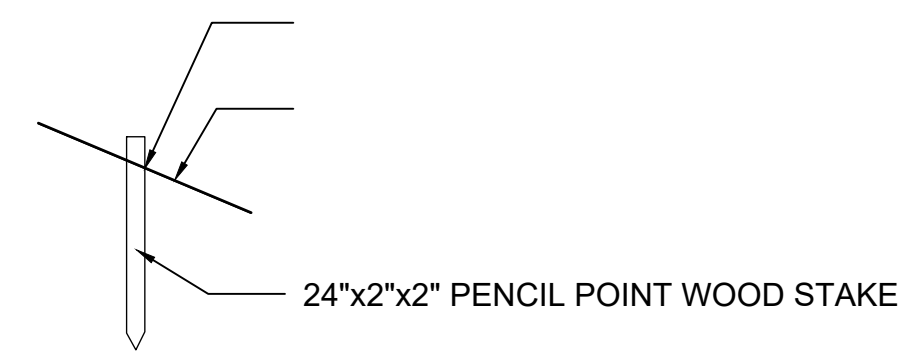

WOOD STAKE DETAIL

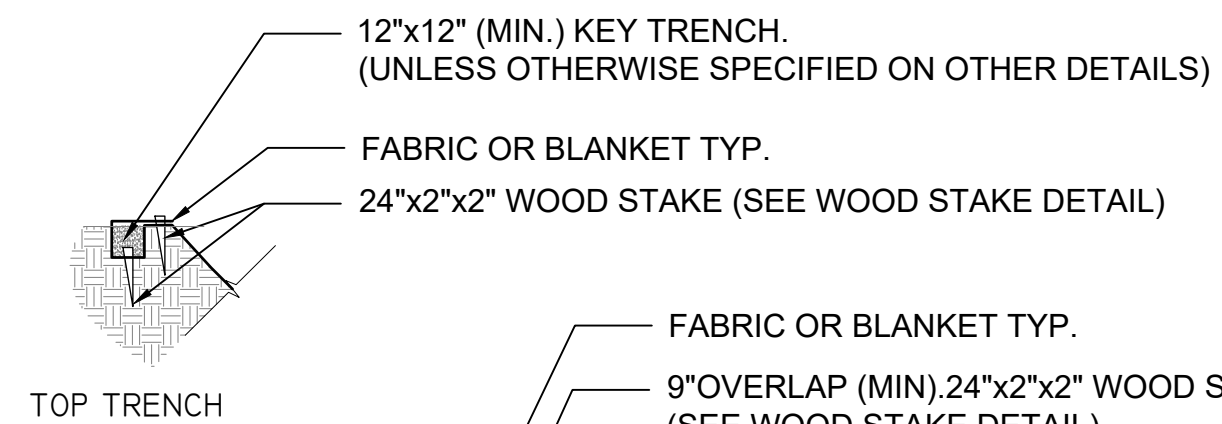

TOP TRENCH

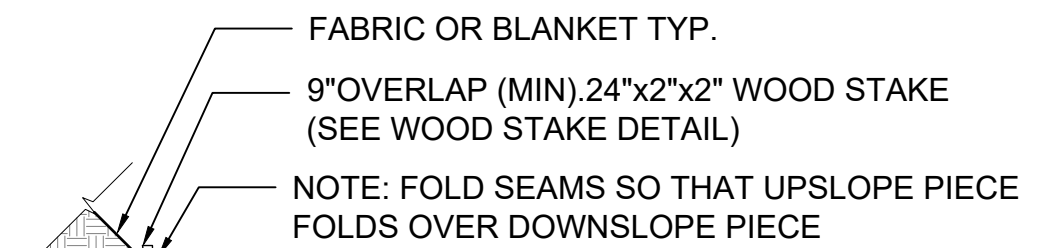

SEAM OVERLAP

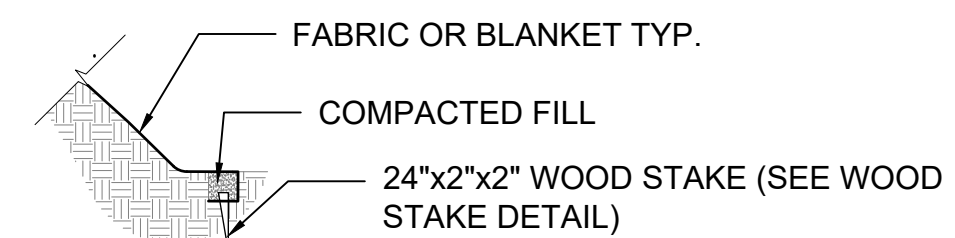

TOE TRENCH

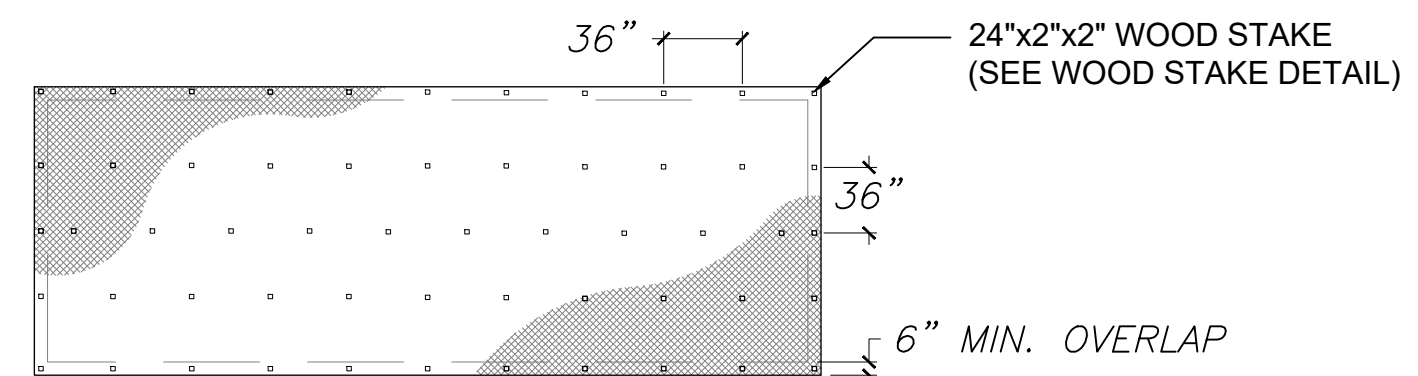

EROSION CONTROL FABRIC

- NOTES:
- WHERE FEASIBLE, FABRIC WILL BE ROLLED OUT AND INSTALLED PARALLEL WITH THE STREAM.
 - UPSTREAM FABRIC PIECES WILL OVERLAP DOWNSTREAM PIECES AND UPSLOPE PIECES WILL OVERLAP DOWNSLOPE PIECES.
 - FOLD OVERLAPPING SEAMS AT LEAST TWICE AND THEN STAKE.
 - AFTER INITIAL STAKING, STAKE FABRIC AS NECESSARY SO THAT IT IS COMPLETELY FLUSH WITH THE GROUND SURFACE.
 - SEED, RAKE, MULCH FINISHED GRADE PRIOR TO LAYING FABRIC.
 - SEE, RAKE, MULCH KEY TRENCHES PRIOR TO CLOSING FABRIC.

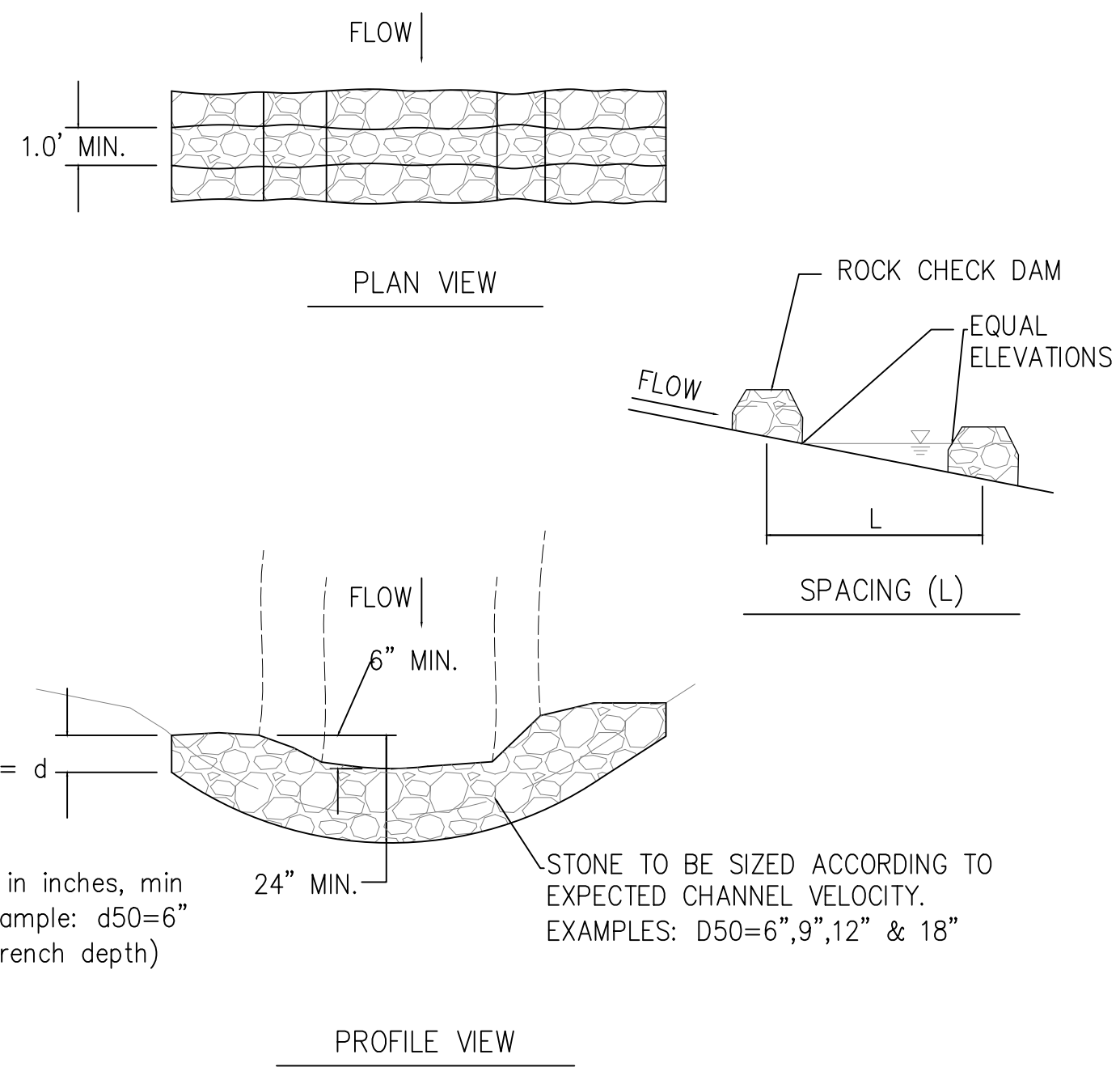

- NOTES:
- CHECK DAMS SHALL BE INSTALLED PRIOR TO UPSTREAM EARTH DISTURBING ACTIVITIES.
 - STONE SHALL HAVE < 10% FINES.
 - EACH END OF CHECK DAM SHALL BE 6" MINIMUM HIGHER THAN CENTER.
 - SEDIMENT SHALL BE REMOVED FROM THE CHECK DAM WHEN THE SEDIMENT DEPTH REACHES 1/2 THE HEIGHT OF THE CENTER.
 - CHECK DAM SHALL BE REMOVED ONCE ALL UPSTREAM DISTURBED AREAS HAVE BEEN STABILIZED.
 - UPON REMOVAL OF CHECK DAM, EXCAVATIONS SHALL BE FILLED WITH SUITABLE COMPACTED FILL, SEDED AND COVERED WITH AN EROSION CONTROL BLANKET ADEQUATE FOR EXPECTED CHANNEL VELOCITY.

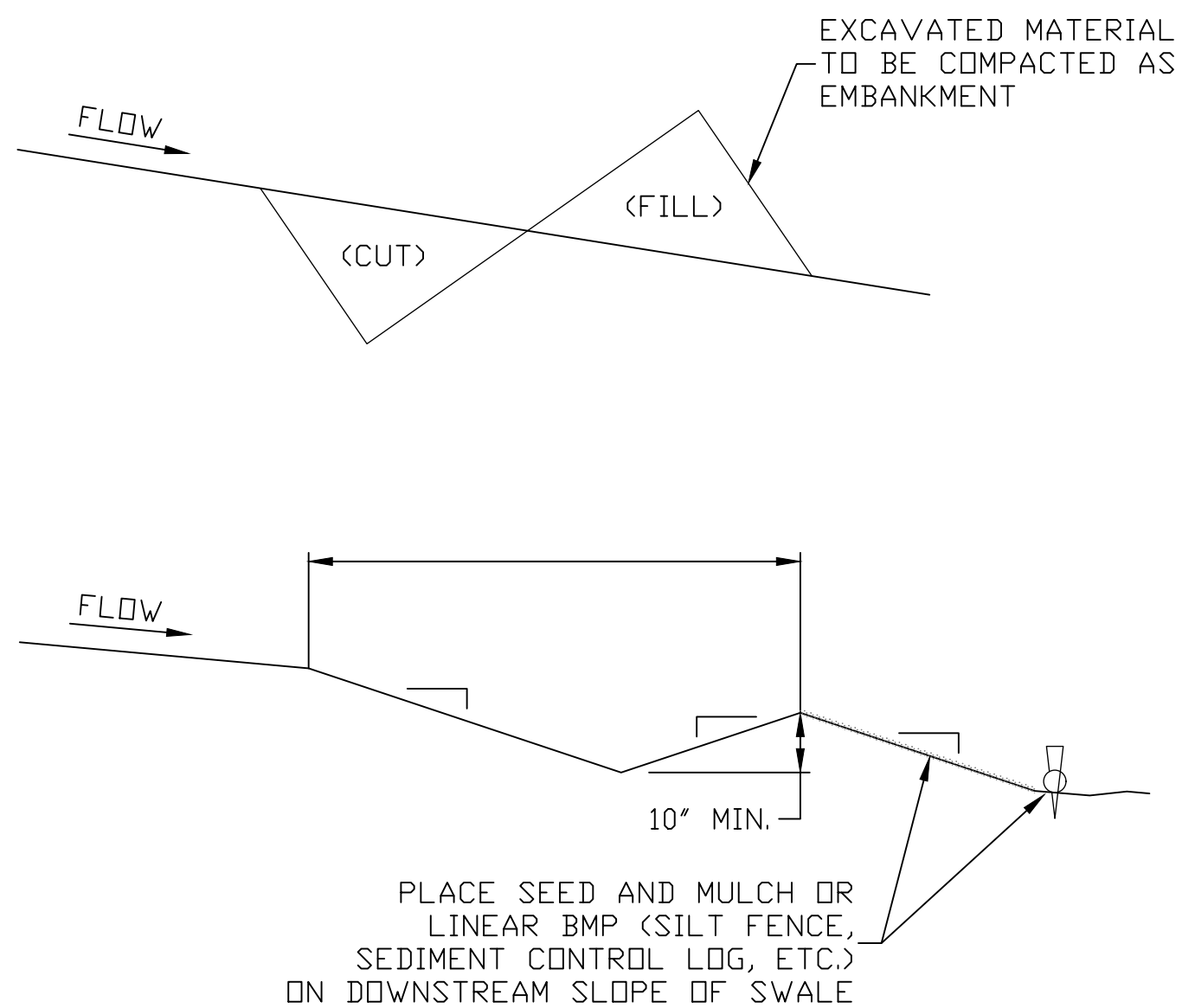

- NOTES:
- CHECK DAMS OR EROSION CONTROL BLANKETS MAY BE REQUIRED IF VELOCITY BEGINS TO ERODE DITCH/ SWALE.
 - DIVERSION DITCHES/ SWALES SHALL BE DISCHARGED TO SEDIMENT TRAPS OR BASINS WHICH HAVE BEEN SIZED APPROPRIATELY.
 - IF SEDIMENT BEGINS TO COLLECT IN THE SWALE, THE SEDIMENT SHALL BE REMOVED WHEN IT REACHES 1/3 THE HEIGHT OF THE SWALE.

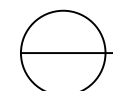
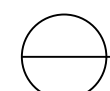

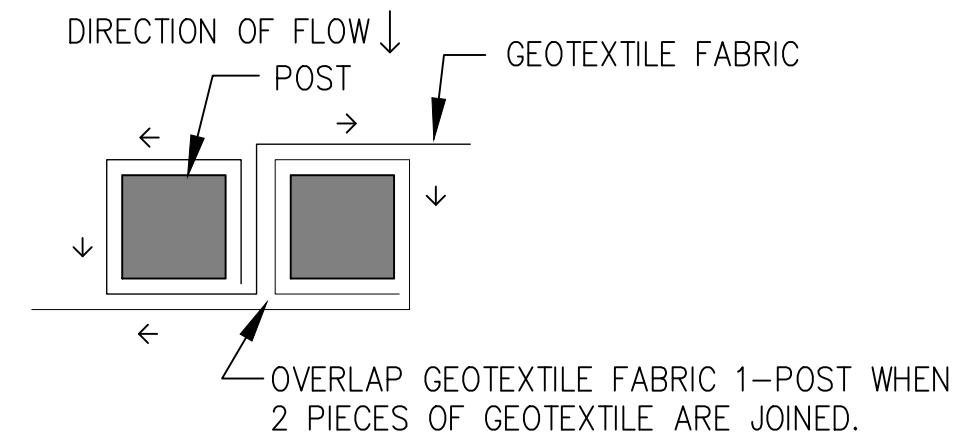

PLAN VIEW: TRANSITION DETAIL

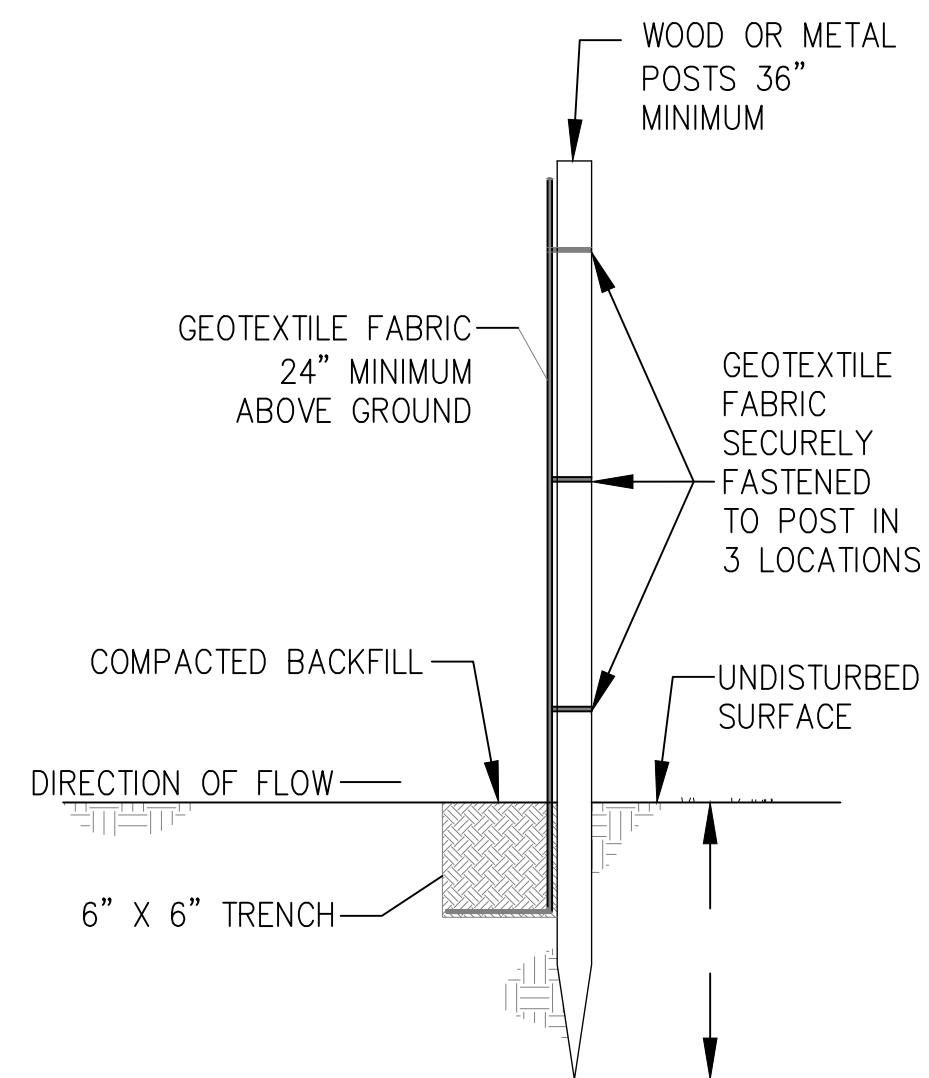
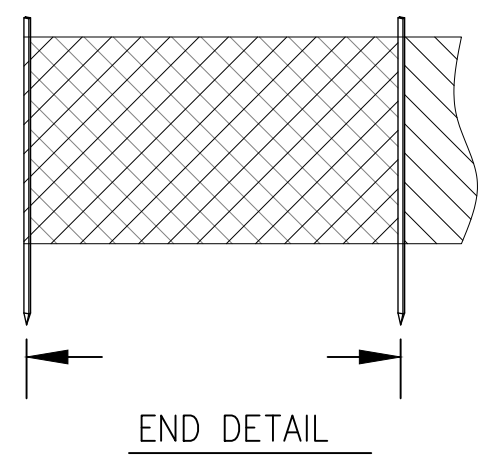
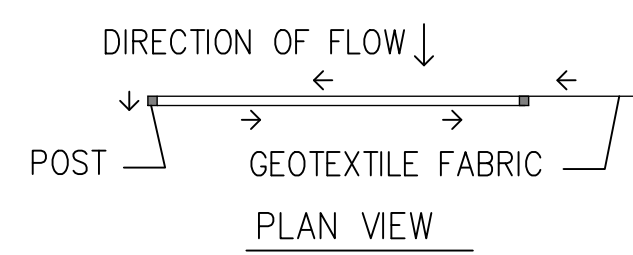

- NOTES:
1. WOOD POSTS SHALL HAVE A MINIMUM DIAMETER OR CROSS-SECTION OF 2 INCHES. METAL POSTS SHALL BE STUDDED "I" OR "U" TYPE.
 2. GEOTEXTILE FABRIC SHALL COMPLY WITH CDOT 712.08b.
 3. GEOTEXTILE FABRIC SHALL EXTEND A MINIMUM OF 6" BELOW GRADE AND ANOTHER 6" HORIZONTALLY IN A "L" SHAPE BEFORE BACKFILLING AND COMPACTING THE TRENCH. (SLICING METHOD IS ALSO ACCEPTED)
 4. SILT FENCE SHALL NOT BE USED IN CONCENTRATED FLOWS. HEIGHT OF THE GEOTEXTILE FABRIC.
 5. SILT FENCE SHALL ONLY BE PLACED PARALLEL TO SURFACE CONTOURS.
 6. CLEAN AND REMOVE SILT WHEN THE SILT REACHES.
 7. UPON PERMANENT STABILIZATION OF AREAS UPSLOPE OF THE SILT FENCE, THE SILT FENCE SHALL BE REMOVED AND DISTURBED AREAS PERMANENTLY STABILIZED.

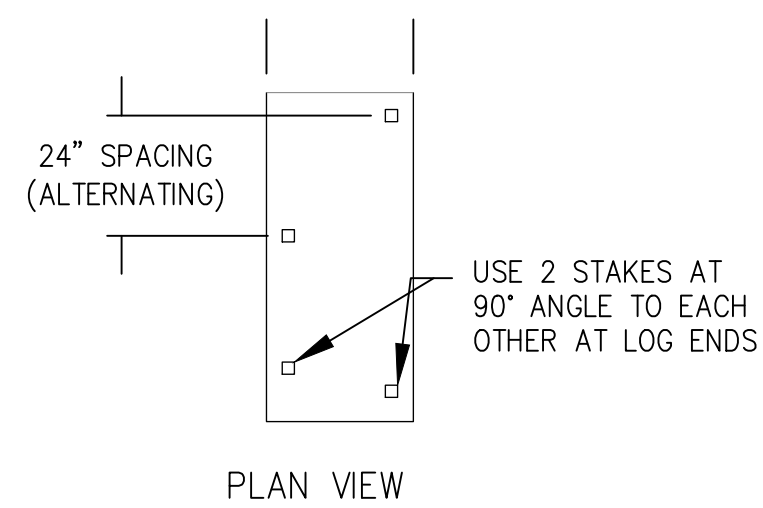
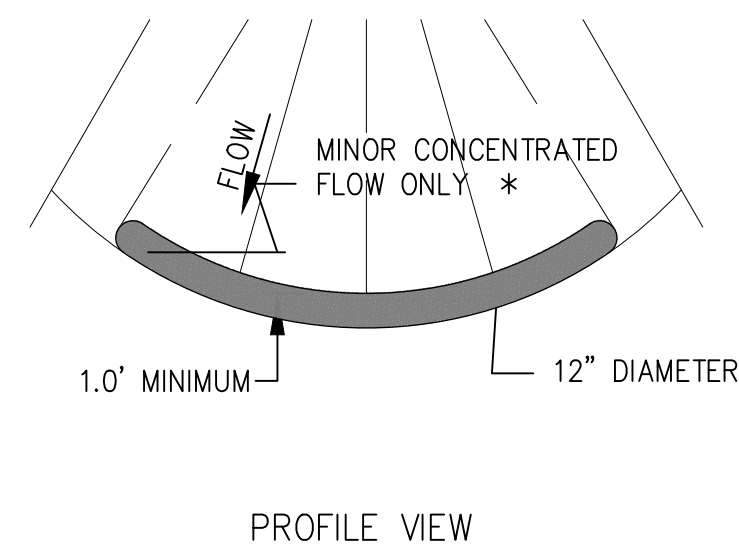
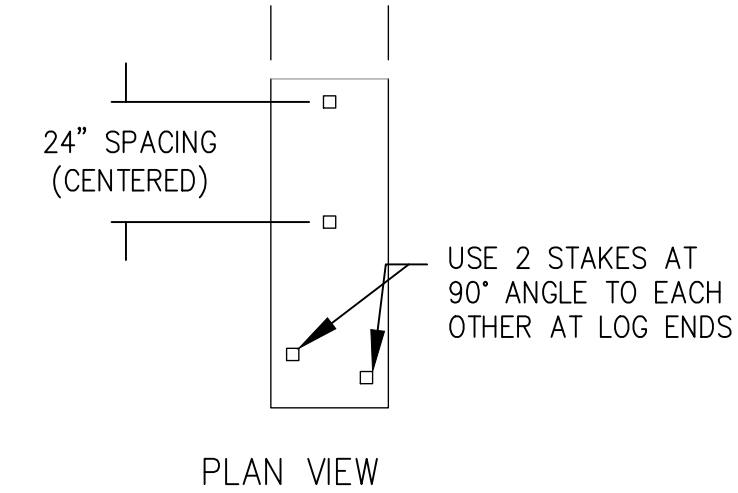
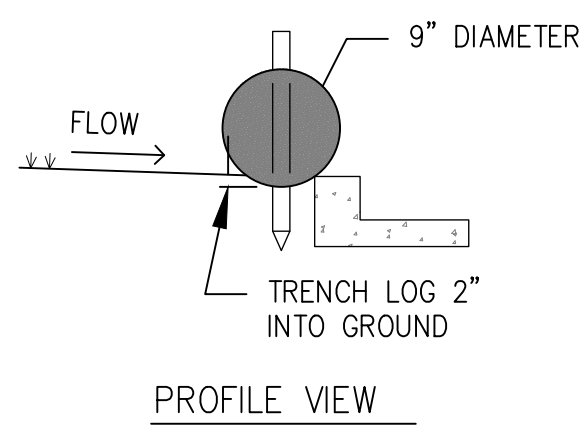
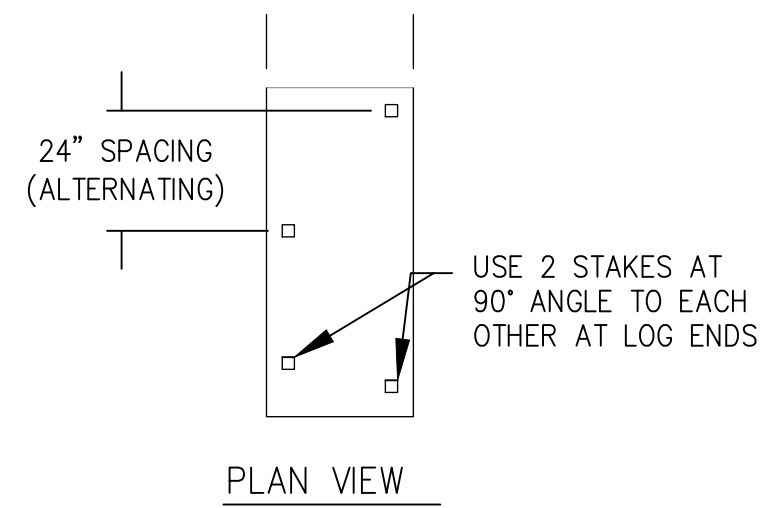
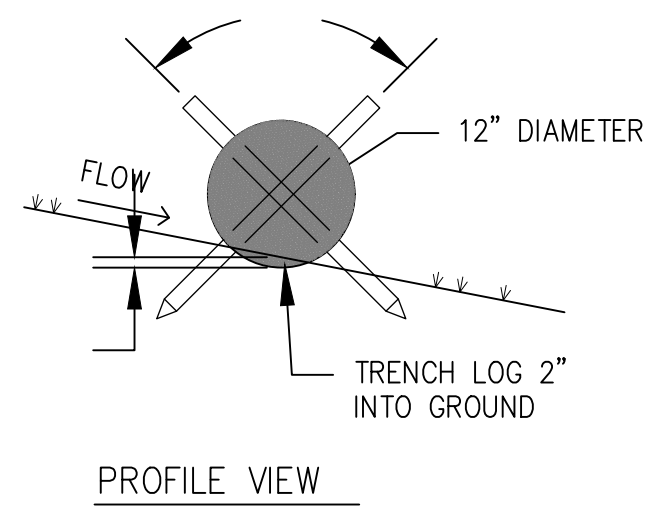

* FOR MAJOR CONCENTRATED FLOWS, USE A ROCK CHECK DAM

- NOTES:
1. STAKES SHALL BE 1-1/2" x 1-1/2" x 24" MINIMUM AND EMBEDDED INTO GROUND A MINIMUM OF 12".
 2. SEDIMENT CONTROL LOG SHALL BE TRENCHED 2" INTO GROUND.
 3. FOR CONTINUOUS CONTROL, ADJACENT SEDIMENT CONTROL LOGS SHALL BE PLACED FIRMLY TOGETHER WITH NO GAPS.
 4. SEDIMENT SHALL BE CLEANED/ REMOVED WHEN SEDIMENT DEPTH IS 1/2 THE HEIGHT OF THE SEDIMENT CONTROL LOG.

Status:
100% DESIGN DRAWINGS

Drawing Name:
TYPICAL BMP'S

Revisions:
--

Drawn By:
NATHAN WERNER, CHRISTINE CLARK

Checked By:
Scott Shipley

Date:
06/21/2021

Vertical Datum:
NVGD 29
ACOE Project:
NWW-2020-440-I02

Stamp:

REUSE OF DOCUMENT:
THIS DOCUMENT IS THE PROPERTY OF ISO DESIGN AND ENGINEERING. THE IDEAS, DESIGN
AND CONTENT INCORPORATED ON THIS DOCUMENT IS AN INSTRUMENT OF PROFESSIONAL
SERVICE AND SHALL NOT BE USED FOR ANY OTHER PROJECT WITHOUT THE WRITTEN
AUTHORIZATION OF ISO DESIGN AND ENGINEERING.

Scale: Sheet:
WW-8.2
32 of 32