

NATIONAL SECURITY AGENCY
AT GEORGE G. MEADE, MARYLAND

Egyptolog

JUNE 1975

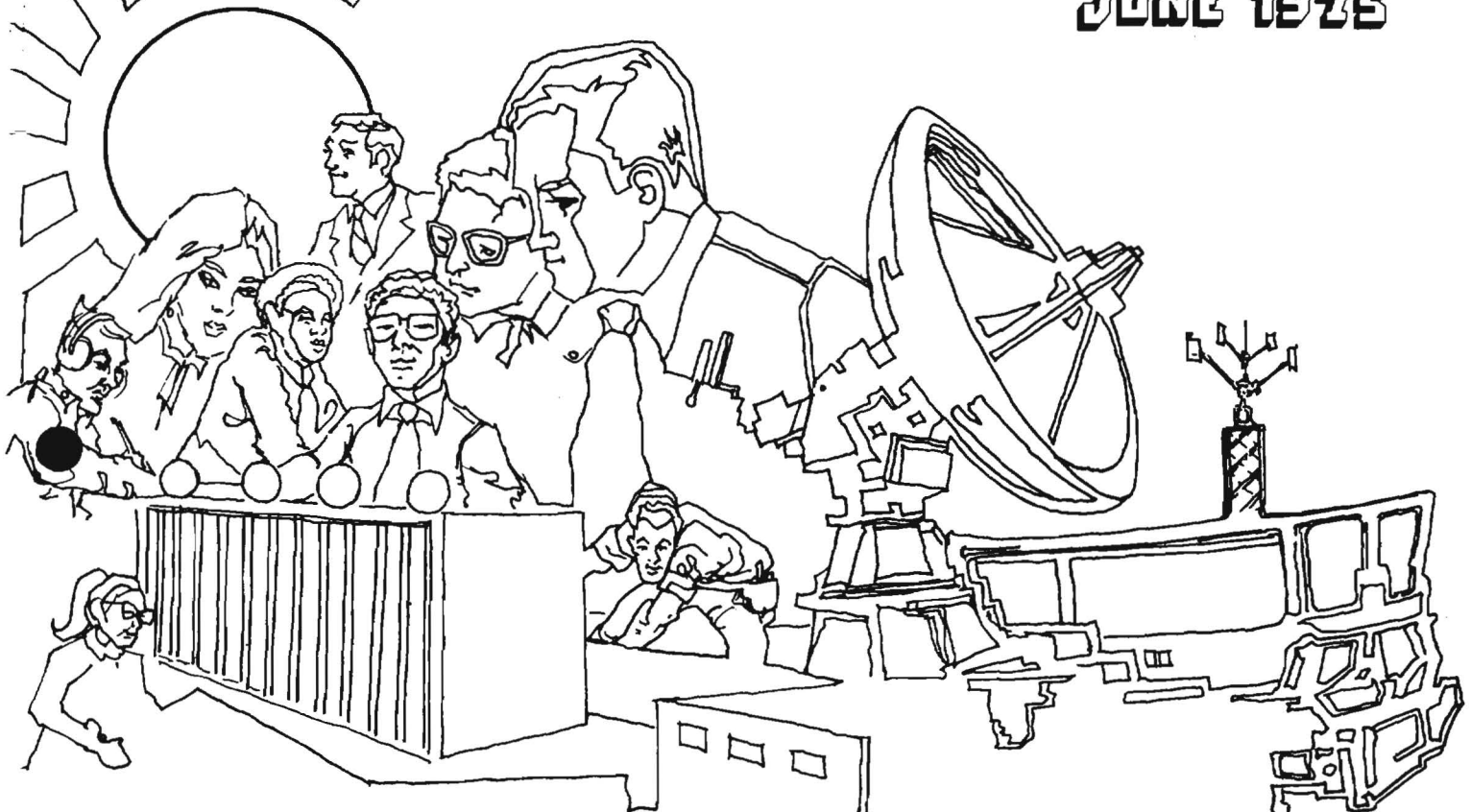

EO 1.4.(c)

P.L. 86-36

ELECTRONIC WARFARE ADVISORY ELEMENT.....	[REDACTED].....	1
MORE ON SQUARING THE PAGE.....	Frederic O. Mason, Jr.....	5
COMSEC FAMILIARIZATION: DO YOU NEED IT?.....		8
WHERE DOES "DOES" COME FROM?.....	Emery Tetrault.....	9
THE NAVAJO CODE TALKERS.....		12
[REDACTED] RADIOTELEPHONE CROSSWORD.....	Thomas L. Engle.....	13
PROFESSIONALIZING IN COMPUTER SYSTEMS.....	[REDACTED].....	14
PROJECT SYMBIOSIS.....	016-22-723A.....	17
LETTERS TO THE EDITOR.....		19

~~THIS DOCUMENT CONTAINS CODEWORD MATERIAL~~

~~TOP SECRET~~

~~Classified by DIRNSA (NSAM 123-2)
Exempt from GDS, EO 11652, Category 2
Declassify Upon Notification by the Originator~~

Declassified and Approved for Release by NSA on 10-11-2012 pursuant to E.O. 13526, MDR Case # 54778

CRYPTOLOG

Published Monthly by P1, Techniques and Standards,
for the Personnel of Operations

VOL. II, No. 6

JUNE 1975

PUBLISHER

WILLIAM LUTWINIAK

BOARD OF EDITORS

Editor in Chief..... Arthur J. Salemm (5642s)
 Cryptanalysis..... [redacted] (3571s)
 Language..... Emery W. Tetrault (5236s)
 Machine Support..... [redacted] (3321s)
 Special Research..... Vera R. Filby (7119s)
 Traffic Analysis..... Frederic O. Mason, Jr. (4142s)
 Production Manager..... [redacted] (4998s)

P.L. 86-36

For individual subscriptions
 send
name and organizational designator
 to: CRYPTOLOG, P1

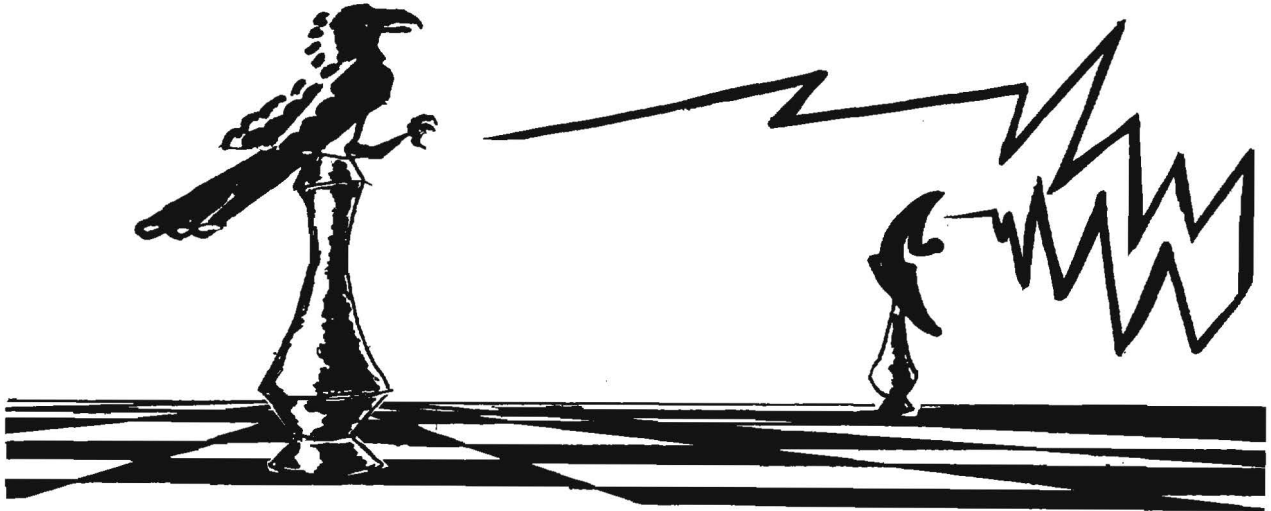
~~SECRET~~

THE ROLE OF THE ELECTRONIC WARFARE ADVISORY ELEMENT (EWAE) OF N.S.A.

By James V. Boone, Chief, W

The following article is a slight revision of a speech given by Mr. Boone in February 1975 to the Capitol Club Chapter of the Association of Old Crows. The Old Crows are a worldwide organization of DoD, industry, and other technical and professional individuals interested in electronic warfare. Their name -- no disrespect intended -- is derived from the fact that, since the first aircraft sent on nighttime EW missions were painted black, the aircraft and then their crews were called "ravens" or "crows."

The 1973 changes to DoD Directive 3115.7 brought a new element of charter to the National Security Agency. That new element was the obligation to provide "SIGINT support to Electronic Warfare."

Prior to that time NSA had been providing such support, but it had been basically reactive and crisis-oriented. Whenever events of a highly volatile military nature occurred, the Agency was asked to provide any and all SIGINT available to explain the phenomena. But there was no designated focal point for EW problems, and the Agency's reporting tended to be fragmented and did not include the maximum interaction between the COMINT and ELINT disciplines that is necessary in this important field. No real attempt to provide long-term intelligence support to EW had been developed.

Further, a basic mistrust of Service Electronic Warfare existed in our SIGINT-trained and SIGINT-dedicated Agency. (How's that for a switch of "suspicion roles"?) The indefinite

line between SIGINT and ESM [Electronic Support Measures] had been debated, cussed, and discussed again and again. One major problem at NSA was that there were very few professional military Electronic Warfare Officers aboard. Those who were assigned to the Agency were scattered through the various groups and hence tended to be ineffective. Of course, none were at any sort of policy level. (Same old story: "Don't know what this EW is all about, but I'd better have a guy that can at least spell it.") Compounding this confusion was the lack of a place at NSA where any of you Old Crows could call or TWX to start getting some idea of where an answer could be found, how to formalize requests, and what type of data could be provided.

Well, the problems were defined but the solutions seemed a long way off. Enter the Electronic Warfare Advisory Element (EWAE). The concept for this group was initially broached in November 1972. A knowledgeable Air Force Electronic Warfare Officer (EWO) from the Air Force Special Communications Center was trans-

~~SECRET~~

~~SECRET~~

ferred to NSA, and the struggle to create an EW focal point began. In spite of some real problems, fear of "rice bowl breakage" in many areas, and just plain red tape, a small group of four officers was brought together in mid-1973 and designated the EWAE.

One of their first tasks was to legitimize the element, establish its roles and authorities, and figure out how to attack what seemed to be an insurmountable problem: how to get the right SIGINT to the right people -- in the right way -- in some sort of reasonable time frame. In keeping with the legendary "slyness" of Old Crows, they hit upon a scheme that has stood up well throughout their existence. They decided to prove themselves by deed, rather than by decree. Using their knowledge of military service R and D programs, test and evaluation problems, operational tactics questions,

and a myriad of other programs, they started to offer their assistance to see if any answers were available at the "fort." Many of you soon found out that, in most instances, it was a case of "suspicions confirmed" -- an NSA analyst had the necessary information, but didn't know that anyone needed it. (I should note here that some of your intelligence requests to NSA left more than a few questions in our analysts' minds.)

A significant milestone was reached when the Air Force agreed to place seven Electronic Warfare Officers in the organization, and the Navy provided two Naval Flight Officers with EW' backgrounds. Since then, an Army billet and a Marine Corps billet have been added. As the personnel roster grew, so did the areas of work. After the usual nine-month gestation period, it was time to give formal birth to the new baby. Weaving their way through the many stops from their office upward, they finally arrived at the Director's office in May 1974. After formal presentations, stressing heavily their accomplishments and future plans, they received the green light from General Allen to proceed with his full support. This charter contained the important caveat that he wanted them to work across organizational lines at NSA to insure that our support was, in fact, SIGINT, rather than some lesser "INT" that was ignoring important pieces of the puzzle. In my own experience in trying to keep up with them, I know that they are (and in fact were, before formal approval) touching base with many Agency functions that were previously unaware of the kinds of things that are important to EW.

Perhaps before I go further into a discussion of some of my EWAE's achievements and programs, I should flash their credentials on you. First of all, they are professional *operational* -- rather than *intelligence* -- people. When I asked them to tell me how professional they really were, I think they were more surprised than I was. The seven Air Force, three Navy, and two Army officers presently assigned came up with the following figures: together, the flying officers from the Navy and the Air Force have 31,000 hours of flying time, over 7000 of which were logged on their 1,600 combat missions. Both of the Army officers have spent combat tours in Vietnam as company commanders. In combat operations the EWAE officers have received: one Silver Star, six DFC's, five Bronze Stars, 84 Air Medals, five commendation medals (with combat devices), two Vietnamese Air Crosses of Gallantry, and one Combat Action Ribbon.

Their operational backgrounds are equally impressive. Flying experience covers the gamut of our EW aircraft. ECM experience is represented from EB-66, B-52 (lots of this), B-58, AC-130 GUNSHIP, and F4C WILD WEASEL aircraft; ESM (or SIGINT, or whatever) experience is

What IS Electronic Warfare?

The official definition of EW (JCS MOP-95) is "EW is military action involving the use of electromagnetic energy to determine, exploit, reduce, or prevent hostile use of the electromagnetic spectrum and action which retains friendly use of the electromagnetic spectrum."

EW is a relatively new weapons systems component, having been developed in the early 1940's. In his memoirs, Winston Churchill said, "During the human struggle between the British and German Air Forces, between pilot and pilot, between AA batteries and aircraft, between ruthless bombing and fortitude of the British people, another conflict was going on, step by step, month by month. This was a Secret War, whose battles were lost or won unknown to the public, and only with difficulty comprehended, even now, to those outside the small, high scientific circles concerned. Unless British science had proven superior to German, and unless its strange, sinister resources had been effectively brought to bear in the struggle for survival, we might have well been defeated...and defeated...destroyed." Churchill called that secret war "The Wizard War," and we know it today as Electronic Warfare.

The secret war continues today, in greatly expanded scope, permeating every facet of military operations. Thrust and counter-thrust, Electronic Countermeasures (ECM) and Electronic Counter-Countermeasures (ECCM) go on throughout the world on a daily basis. To assure that the present U.S. "strange and sinister resources" receive the intelligence necessary to remain a step ahead of potential enemies, NSA must insure that the SIGINT support provided is timely and accurate, and fills the needs.

~~SECRET~~

represented by flying time with many diverse U. S. Navy and Air Force programs.

And their staff experience is also impressive. The Chief of the EW/Photo Recce Division of 7AF (and later MACV [Military Assistance Command, Vietnam]) during the 1972 LINEBACKER bombing missions in North Vietnam is my current EWAE boss. His Crows have staff experience with HQ 7th AF, HQ PACAF Air Defense Analysis Center, USAFE collection and analysis, various bomb wing staffs, and tasking and mission planning for SAC's 55th Strategic Reconnaissance Wing. The senior Army EW has just returned from Korea, where he was the 2nd Division EW.

With these credentials I expect a lot of work out of my EWO's -- and they've lived up to my expectations. Their work covers the complete spectrum of EW. I'd like to give you a small sample of some of the programs -- many of which directly affect some of you -- in which they have insured that the best SIGINT available was supplied.

The Yom Kippur War. During the early stages of the October 1973 War the Israeli Air Force was taking it on the chin from some of the relatively unknown new SAM systems. The implications of their problems were directly pertinent to our own Navy and Air Force. If, for some reason, we became involved in the Mid-East, both of these services might have faced both the Soviet Navy and the Soviet air defense systems deployed in Syria and Egypt. Our RHAW [radar homing and warning equipment, which provides threat warning of SAM and AAA threats to the aircraft] and ECM people were stymied. Before they could make equipment changes to counter the threats, they had to understand the threats. This meant real-time reporting of any new intelligence about the systems -- particularly the SA-6¹. The possibility that intelligence might be shut off from key service personnel by classification caveats became a real problem. The EWAE, recognizing this, initiated a series of reports that they called "Threat Parameter Messages." These messages, at the SECRET classification, reported any new defense-system information to U.S. military users on a real-time basis -- even while the formal reports were in the draft stage. The addressee list currently includes over 75 operational entities, predominantly in the Navy and Air Force. These messages were greeted with great approval by the operational forces and have been continued with increased distribution since the end of the war. As new systems appear, any and all parametric information available is being "flashed" to the guys that really need the information at a security classification that is useable.

¹See CRYPTOLOG, April 1975, pp. 5-6

Support to the Continental Operations Range and Electronic Warfare Joint Test. In this activity, we fulfilled the need for a comprehensive understanding of enemy command and control. A team organized by the EWAE from three NSA Directorates participated with the range Intelligence Working Group to insure that the message simulation and replication necessary was "according to Hoyle." ELINT information was furnished to radar simulator builders. These efforts were recognized by letters of appreciation to the individual team members from the COR Op Commander, General Blood.

CROSSBOW "S" Committee. The CROSSBOW "S" Committee, chartered by the Joint Coordinating Committee on Defense Electronic Systems, is organized to study and make recommendations to the military services in matters concerning the development of threat simulators². One of my EWO's acts as an advisor to this group. To date he has insured that the latest ELINT information on surface-to-air missile systems has been passed directly to these developers, instead of being hung up in a distribution system.

Navy EA-6B Program. For over a year my EW's have been working closely with the Staff of the Navy's EA-6B program at Whidbey Island, Washington. As the EA-6B is the only dedicated U.S. electronic warfare aircraft in the inventory, the proper use of the many types of jamming it can perform against specific threats becomes a critical operation. To assist these Navy planners, my people have insured that inputs of SIGINT data necessary to do the job right are constantly pumped to them. These efforts have earned the EW's and NSA a very nice letter of appreciation from Admiral Tierney of COMMATVAQWGPAC.

Air Force Special Communications Center. Our COMFY COAT³ friends must be considered one of the key agencies in the EW game. To do their job they need all kinds of intelligence -- quickly, accurately, and with full implications of peripheral happenings in any given incident. To better help them get their job done, the EW's at NSA act as a focal point for any and all requests for information. During the last year we've answered over 200 separate inquiries. Further, to improve the exchange of information the EWAE played a significant role in getting NSA to place a permanent representative at the center. This representative, with his knowledge of the workings of NSA, has been beneficial to both agencies in getting the job done -- and to the best of our combined abilities.

²Simulation of enemy radar systems for use in training U.S. combat personnel.

³Nickname of a series of special reports and evaluations covering all facets of Electronic Warfare operations and training.

These are just a few examples of how the initiative and operational knowledge of my EW's has paid off. The payoff for NSA has been the exposure of our analysts to the real world of EW and its operations. The best-written intelligence request is a poor substitute for a face-to-face exchange between the user and the producer, but that is the system under which we are forced to operate. In the previously mentioned support areas, my EW's have participated with NSA specialists in many areas of expertise. The personal relationships that have developed have made a great impact on the direction of efforts by the NSA analysts. The old adage of "Don't ask questions, just do/give me what I say" does not fit our EW/intelligence interface world.

Some New Ideas

Two years ago, at the Old Crow National Convention, NSA presented a briefing on a computer-based catalog of ELINT parameters called KILTING. To my amazement I find many of you have never heard of the program. This "alive-and-well" catalog of everything from SIGINT worth knowing about threat, and other signals, is a must for almost all EW programs, be they ESM, ECM, or ECCM. The parametric tree that started out with just pulsed signals has now expanded to include CW signals, and a tree for inclusion of ECM signals is now being developed. This latter brings me to a subject that is really dear to my EW's. They have gone around NSA spouting such heresies as, "We really should understand Soviet EW capabilities" and "Why don't we collect some of that stuff once in a while?" Some initial reactions were "Even if I understand Soviet EW, what can I do with it?"

Now I know that ECCM is the poor stepchild of EW, but for those of you involved in it, I'll bet that a completely catalogued documentation, giving parametric data such as modulation techniques and other goodies, would be a godsend. How about you designers? Have you just built, or are you contemplating building, a radar, SAM system, AWACS, ESM gear, Terrain Following Radar, etc. that just happens to be completely vulnerable to enemy jamming? For you communication and data link experts, the impact is equally important.

So, undaunted by opposition, the EW's have supervised collection-tasking plans against non-U.S. radar and communications jamming. As these reported incidents come in, the information will be filed in the ECM tree of KILTING. I think that the EW community, as well as the intelligence community, will finally have a viable, useable, up-to-date catalog of what we know about the "bad guys."

On the other side of the coin is the need to know how best to get into the enemy's radar, communication, and control nets. How do we jam system "X" effectively? Where is the system's weakest link? What type of power, modulation, polarization, etc., will be effective? Now this need surfaces a little-known but easily understood fact: we jam receivers, not transmitters! Logically, then, we need to understand how the receivers work. But unless our friends supply us with some equipment to look at, or we stumble across a maintenance manual, this becomes a tough nut to crack. New threat systems are seldom at our disposal, and the first time we'll really try to jam them is when the balloon goes up.

Enter my EWAE again. How successful would we be, they asked themselves, if we took the external system knowns (such as SIGINT), gave them to a smart radar designer, and asked, "If this is what you transmit, how must your receiver work?" They called this study "Radar Performance Assessment" and later "Project HEADPIN." Starting with known (exploited) equipment, they constructed a tree into which pertinent information such as IF frequency and bandwidth, STC, and ECCM circuitry could be recorded. Project HEADPIN is alive and well, and initial product is becoming available. Due to the amount of calculations, estimations, and even WAG's⁴ necessary in a program such as this, complete algorithmic documentation will accompany any Project HEADPIN product. The next step in the process will be to assess a new threat system with minimum knowledge of operating characteristics. It should prove interesting and can really get us involved in some interesting arguments, but at least it will provide a departure point for anyone involved in designing jamming equipment.

⁴An alternate expansion of this informal abbreviation is "very broad guess."

Who needs the EW-related information that NSA can produce? ESM and ECM planners, builders, and users need to know about enemy radar and communications systems. Counter-countermeasures planners, builders, and users need to know about enemy EW capabilities. Military operational planners need to know about enemy EW doctrine and employment, location of electromagnetic systems, and the capabilities of these systems against our forces. In summary, anyone who plans or performs the design, construction, or employment of electronic equipment is a potential user of some facet of SIGINT produced by NSA. The EWAE welcomes any questions, comments, or suggestions related to this support of the EW community. Please contact the EWAE (W07) at Extension 3610/3619s, or visit us in Ops Building 1, Room 3W136.

M	O	R	E		O	N											
S	Q	U	A	R	I	N	G		T	H	E		P	A	G	E	
	(A		C	R	Y	P	T	O	-	T	A					
		F	U	N	C	T	I	O	N)							
F	r	e	d	e	r	i	c		O	.		M	a	s	o	n	
P	1	1											J	r	.		

In "TA, Handmaiden of CA" (CRYPTOLOG, May 1975) Mr. Mason presented a problem on squaring a callsign page. The answer to that problem is the following callsign page, or some transposition of it in which each row and column contains calls in one of the rows or columns shown.

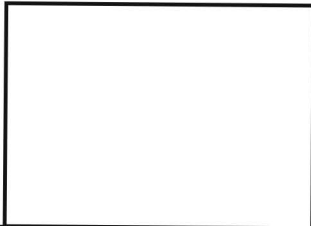

EO 1.4.(c)
P.L. 86-36

And now for another problem:

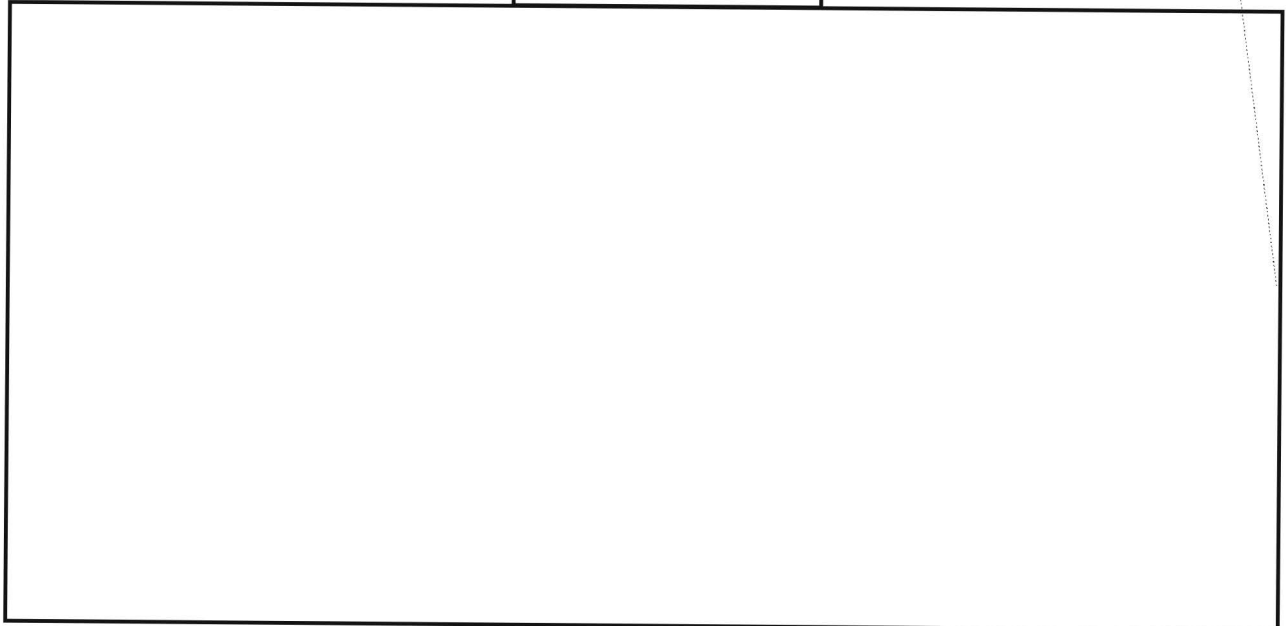

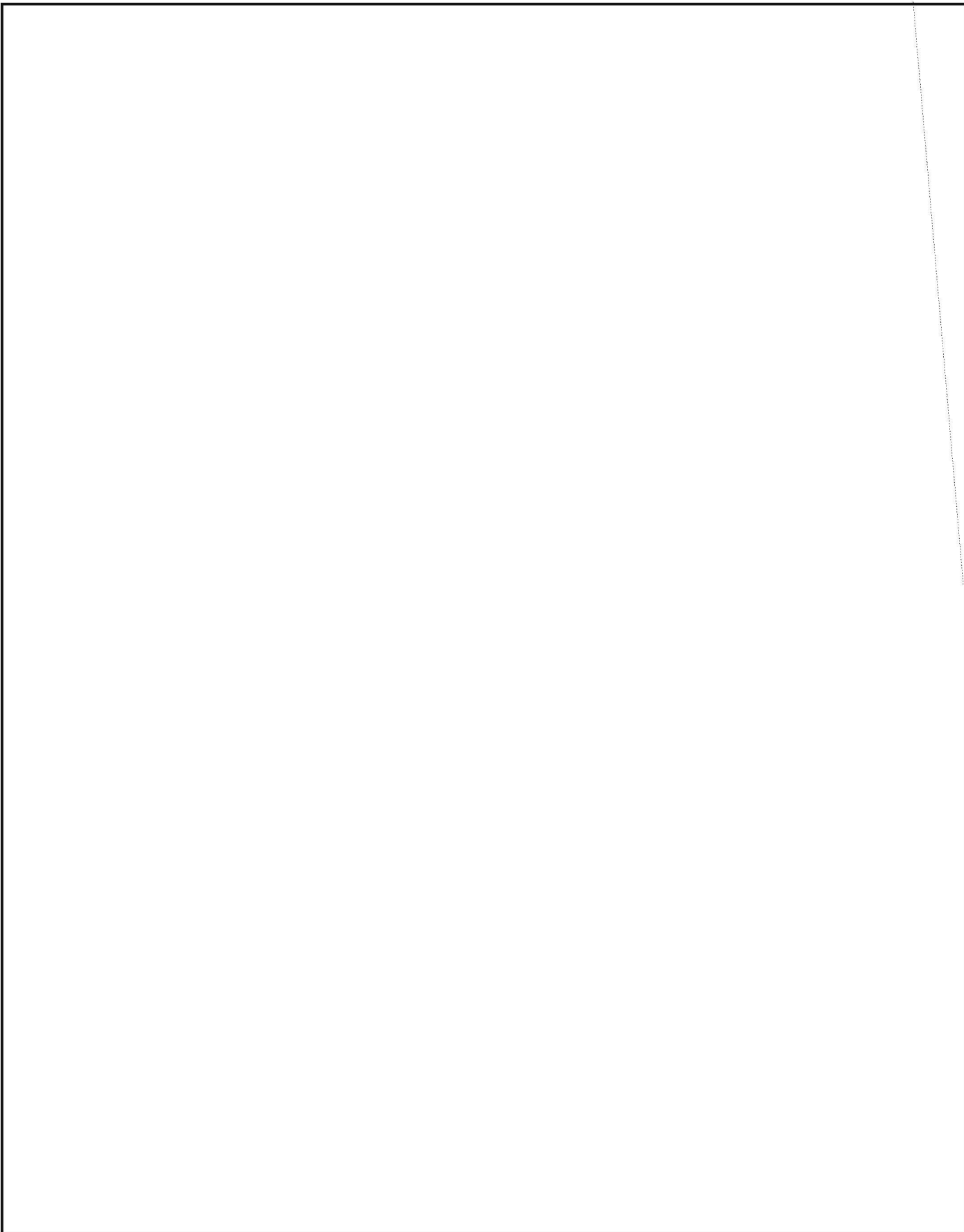

IMPORTANT ANNOUNCEMENT!

Because of its personnel losses, S362 is no longer able to address Agency publications, including CRYPTOLOG, to individuals by name. Instead, it will send publications only to an organizational designation. S362 has agreed to use the following procedure with CRYPTOLOG's machine-printed mailing list: it will put into one package the total number of copies addressed to the same organization, and will enclose any machine-printed stick-on labels bearing names of individuals.

Please make sure that someone in your mailroom is prepared to receive these bulk shipments of CRYPTOLOG and is willing to slap the labels onto the individual copies, thus assuring that everyone gets his or her copy promptly. If your mailroom has suffered its own personnel losses and considers these extra few minutes' work an imposition, you might like to organize a "CRYPTOLOG labeling bee" each month.

Incidentally, the serial number that each copy of CRYPTOLOG now bears is NOT a document control number. It is a *production* control number used by S32 to check the total number of copies printed. (U)



EO 1.4.(c)
P.L. 86-36

~~CONFIDENTIAL~~

COMSEC FAMILIARIZATION -

Do you need it?

In going about your daily SIGINT chores in this Agency, have you ever given any thought to the other side of the coin--that is, to COMSEC? Have you ever had need to consider any of the following questions:

What is COMSEC? Why do we need COMSEC? Where do we need COMSEC and where can I find what is available? Who is working on COMSEC in NSA?...in the rest of the Federal Government? When should COMSEC be considered in any communications or in any SIGINT system? Which COMSEC equipments or systems could be used for which applications? When are the new developments in COMSEC equipments, systems, and doctrine going to be made available? How much COMSEC will I need and how much will it cost?

If you have never considered any of the questions, you are a prime candidate for CS-130; if you have considered them but cannot answer them right now, you are also a candidate for the course. CS-130 is titled "COMSEC Familiarization for Engineers," but don't let the title mislead you. The course is designed to provide a broad orientation in COMSEC to engineers, yes, but also to other technically qualified people working in COMSEC, SIGINT, or communications, who have only a sketchy knowledge of the subject.

CS-130 is offered twice each year to Agency personnel: in September and in January. It is a full-time course which lasts six days. In addition to guest lectures by Agency COMSEC authorities, there are tours of laboratories and "hands-on" demonstrations of the COMSEC equipments.

Up to now, CS-130 has been offered nine times to 270 students from Army, Navy, Marine Corps, Air Force, Coast Guard, civilian agencies, Defense agencies, and NSA. But only two per cent of the students have been from the SIGINT side of NSA. Maybe those in SIGINT just don't know the course exists.

* * * * *

E13 (NCS Cryptanalysis Department)
can give you additional information
about CS-130. Telephone ext. 8025s.

A typical course schedule is as follows:

Monday:

Introduction to Cryptography, The Threat to U.S. Communications, The National COMSEC Structure and the USCSB,



Tuesday:

Digital Encryption Theory, COMSEC Record/Data Equipments, Computer Security, Transmission Engineering and COMSEC.

Wednesday:

Speech Encryption Techniques, Secure Voice for Combat Net Radios, Tour of COMSEC Engineering Laboratories, System Application of Cryptography.

Thursday:

Introduction to Research and Engineering, COMSEC Techniques,

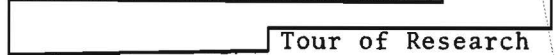

Tour of Research and Engineering COMSEC Laboratories,

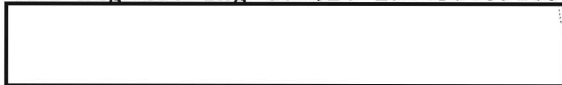

Friday:

COMSEC Material Production, COMSEC Applications to Weapons Systems, Survey of NATO Cryptography, COMSEC Applications to Space Systems.

Monday:

COMSEC Resources, Physical Security, COMSEC Management and Summary.

* * * * *

If the agenda whets your appetite, see your friendly Training Coordinator immediately; fill in Form E7687B; and send it forward through the proper channels. Then you will be in line for the next offering of CS-130 to Agency personnel--8 September 1975. Remember, COMSEC should never be an afterthought in the design and development of SIGINT systems.

~~CONFIDENTIAL~~ ~~HANDLE VIA COMINT CHANNELS ONLY~~

Where does "does" come from?

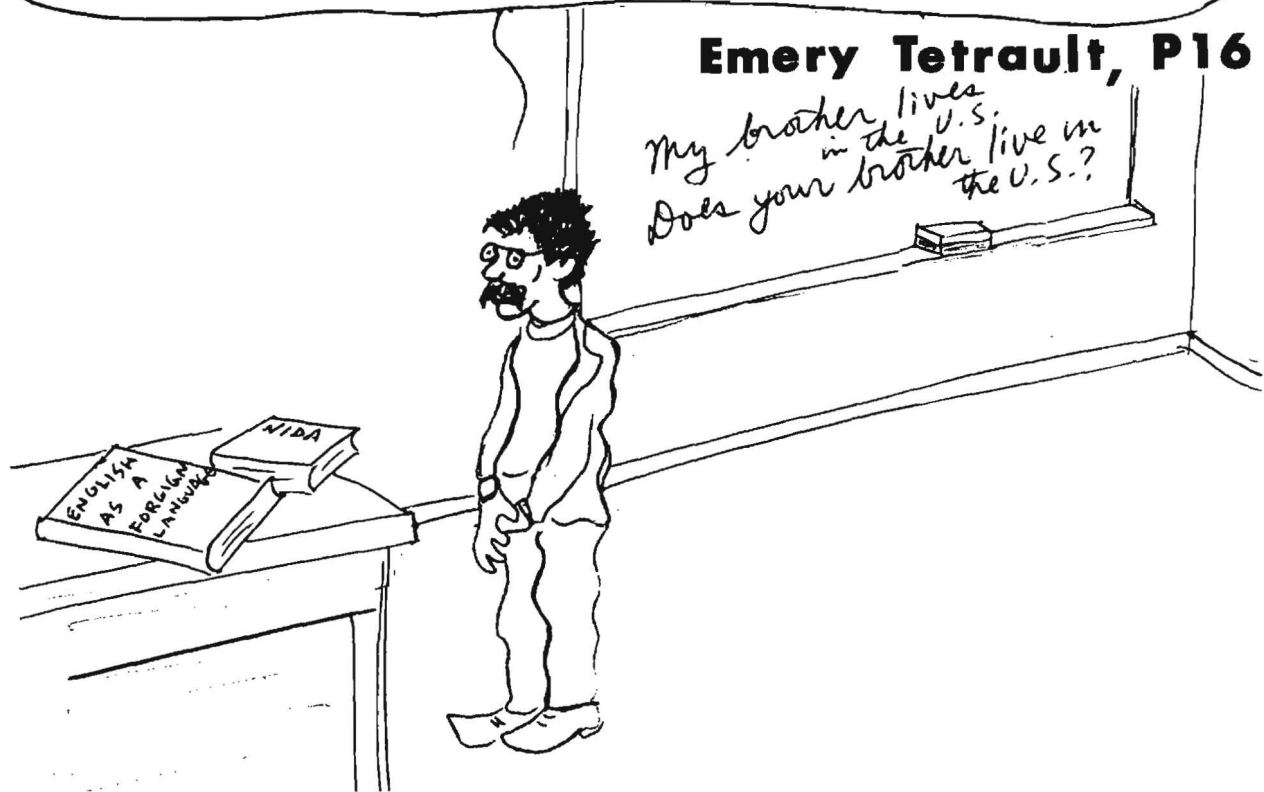

Maybe it's the ravages of spring or maybe it's nothing more than my normal tendency to be introspective, but I've been brooding lately about the applicability of linguistics to practical language work. Much of what is currently being discussed in the name of linguistic science smacks more of philosophy than science; what often passes for linguistic argumentation is more reminiscent of the Empiricist/Rationalist debate than of anything connected with human languages.

Nevertheless, people continue to work with real languages and they are interested in drawing useful inferences from language data. It is, therefore, not unreasonable to assume that the same people might be interested in some kind of systematic method or procedure for generalizing language data, whether this method be called transformational grammar, structuralism, tagmemics, or whatever.

The story below may not seem especially enlightening for NSA language analysts. It's about English and most NSA employees already know everything about English. Moreover, it's about teaching English, something almost none of us does on the job (more irrelevance!). It does, however, illustrate what a linguistic method is and how it can be used.

A couple of years ago I was teaching a course in English as a foreign language and this experience provided an example of just such a method. The class was made up of Spanish and Korean speakers, with a Chinese (Cantonese) and a Frenchman included to make any contrastive approach unthinkable. The class was far enough along to permit fairly easy communication in English between instructor and students, and we were plowing through a review section devoted to positive, negative, declarative and interrogative sentences. The actual drill involved changing positive sentences to negative ones and it was proceeding smoothly, if not spectacularly, toward the coffee break when suddenly, as if in a dream, I heard the fateful words:

"Where does *does* come from?"

To understand what prompted such a question, we should back up a bit and look at what had been going on. All the sentences in the drill up to that point had contained a modal auxiliary (e.g. *can, shall, may, will*). The students were forming negative sentences by simply putting the word "not" after the modal, e.g.:

The new student can speak English.

The new student can NOT speak English.

It sounds pretty basic, but this is often the stuff that language drills are made of. Unfortunately, toward the end of the exercise someone slipped in a sentence without a modal:

My brother lives in the United States.

*My brother lives NOT in the United States.

(The asterisk indicates an incorrect or hypothetical form.)

In the question quoted above, my inquisitor was reacting to my somewhat irritated correction of what he had just uttered. Nonetheless, his question was a good one and it deserved an answer.

My first impulse was to fall back and regroup around the native speaker's true companion: "That's the way we always say it." I can still remember my Russian teacher extolling the beauty and logic of a structure in which numerals from two to four govern a genitive singular noun, even though adjectives within the same string continue to appear in the plural form (but not necessarily genitive). His most telling argument was that everyone he knew said it that way.

In a sense, our whole approach to teaching foreign languages has tended to make a virtue out of this kind of reaction. As a result it has become axiomatic among contemporary language teaching methodologists that language patterns, structures, usages, processes, or histories are not to be pointed out, discussed or *explained*. Otherwise, language learners (as opposed to students) are likely to be intimidated, or at least inhibited, and shut up like clams. There is a basic assumption that adult learners can, unaided, infer "rules" from language data; that is, from foreign-language utterances which are sorted out, graded for difficulty and repeated with only the minutest variations for an hour at a time. Perhaps this theory of second-language learning is based on observations of first-language acquisition in children. Nobody ever told my seven-year-old daughter about "does" but she gets it right all the time. To my knowledge she has never said anything like:

*Robert has NOT the funnies.

If little kids can get it right, so what's the big deal?

At this point (not in time, but in this narrative) I was literally saved, not by the bell, but by a gong announcing the coffee break. The moment of truth passed into awkward socializing and by the time we returned to class, the incident was apparently forgotten.

The next exercise in the book involved changing positive statements into yes/no questions. We went over the mechanics of the operation, which consisted of transposing the subject noun phrase and the auxiliary, and once again we set out across the minefield.

The new student CAN speak English.

CAN the new student speak English?

Mary WILL be at the party.

WILL Mary be at the party?

Pedro WORKS in Washington.

*WORKS Pedro in Washington?

Oh, damn! (inserted by instructor, not in text)

It was obvious that I was not going to escape. I leafed mentally through a number of possible explanations, lengthy and elegant descriptions filled with such locutions as "plus/minus modal," "deep structure," "deletion of AUX," etc., but in the end I decided to go over to the offensive (otherwise known as the Socratic method).

The key to the issue (as much for me as for the students) was to see the language as it really is, without imposing any preconceptions on it. It was plain from the material before us that the normal pattern in English is for the verb to consist of more than one word. All the negative, all the interrogative and all but two of the positive declarative "stimulus" sentences in the drill had the so-called "auxiliary slot" filled. If this is the normal pattern, then how can the anomalous one, the simple verb form, be explained?

One method, advocated by Eugene Nida among others, is to arrange such anomalous strings in a hypothetical form which replicates the normal or statistically prevalent pattern. Thus, it is possible to observe what happens to the normal pattern in such odd-ball cases and what environmental or contextual factors, if any, are associated with the anomaly. This is what we attempted to do:

The new student CAN SPEAK English.

Mary WILL BE at the party.

*My brother DOES LIVE in the United States.

*Pedro DOES WORK in Washington.

In the latter two instances, two things had to happen in order for us to get from the hypothetical to the real: (1) the DO form had to be deleted and (2) the inflectional suffix -S had to be moved to the other verbal element (the verb base), e.g.:

Pedro ~~DOES~~ work-S in Washington.

This operation, as trivial as it may seem to us native speakers, was not at all obvious at first to adult learners of English.

The next part of the analysis was considerably less trivial from any point of view. We wanted to be able to predict when the DO form stays and when it goes. Again, looking at sentences with DO forms in them, we finally noticed something (although not without some gnashing of teeth). The sentences with DO forms undeleted had the auxiliary slot *separated* from the other verbal element, e.g.:

My brother DOES not LIVE in the United States.

Robert DOESn't HAVE the funnies.

DOES Robert HAVE the funnies?

DOES Pedro WORK in Washington?

Our hypothetical forms (i.e., the "regularized" treatments of what had been simple verb forms) showed us that the deletion-plus-transposition process took place when there was no such separation between DO and the verbal element, e.g.:

*Robert DOES HAVE the funnies. → Robert has the funnies.

(If you are wondering what we did about the emphatic use of DO, it was noted, but not developed beyond that point. The emphatic DO has been described as a different morpheme, because it differs in stress from the "other" DO form, but I did not feel that either the class or the instructor was ready for such diversions).

It would be foolish to claim that this anecdote illustrates in any comprehensive way "the" linguistic method. This leisurely passage of arms was little more than a brief skirmish in a remote and little-contested sector of the front. Nevertheless, it demonstrates some of the main features of any usable approach to language data.

A linguistic method is first and foremost a *discovery procedure*. It proceeds from observable facts (texts, transcripts, etc.) to a set of generalizations, not from invulnerable first principles to inevitable conclusions.

It is *objective*. The language should be allowed to speak for itself. My initial problem in explaining the English auxiliary-plus-verbal system was based on an unfounded assumption, namely that the simple form of the verb

is somehow the base form from which all other verb "tenses" are derived. A proper analysis would have started with the observation that almost any valid sample of English sentences contains more multi-word verbs than simple verbs.

Finally, a linguistic approach to language data should allow us to *predict future language events*. This is the only kind of inference which has any practical value. My English students found it useful to predict the comings and goings of DO. Most NSA language analysts find that it is of inestimable value to have the ability to predict similar events in their operational languages. This is particularly true, since we are the *outsiders* in a communications exchange and since we must work with language materials which are both corrupt and incomplete most of the time. Given such job conditions, we need all the help we can get, starting with a rigorous and systematic way of dealing with the actual facts of a specific foreign language.

If in the past we have concluded that there is no practical way of applying linguistics to NSA work, the reason for this may be that we have been looking at the wrong kind of linguistics. Those of us who heard Dr. Esther Matteson of the Wycliffe Bible Translators at a recent CLA meeting could not help being impressed with the emphasis that she placed on linguistics, both as a method of rationalizing the translation process and as a method for discovering the forms and processes of a new language. It became increasingly clear from her talk and from the discussion period afterwards that she was not thinking about linguistics in terms of theoretical speculations on the universal nature of man's communicative competence, but rather she was referring to a data-based approach to natural-language phenomena. Maybe we ought to consider changing our brand of linguistics.

* * * * *

In true schoolteacher fashion I cannot finish without giving an assignment: Which form of the French adjective, masculine singular or feminine singular, should be used as the base form from which the other can be predicted? If you have settled that question in your mind, how would you describe the process of getting from one form to the other? *One hint*: Don't be too concerned about spelling; concentrate on the way words sound. See E. Nida, *Morphology*, U. of Michigan Press, 1949, p. 75 for a fuller statement of the problem and also for the solution.



THE NAVAJO CODE TALKERS

The following article is reprinted, slightly condensed, from the February 1975 *Field Information Letter*, which had reprinted it from *The Wall Street Journal*, 12 December 1974. We think it is worth a page to confirm what has floated around in most people's minds as a vague and somewhat dubious legend of the COMSEC trade. A recent acquisition of the NSA Technical Library, *The Navajo Code Talkers*, by Doris A. Paul, tells the whole story.

Navajos weren't the first Indians used by the U.S. military to confuse foreign enemies; Choctaws transmitted orders by telephone for the Army infantry in World War I, and early in World War II Comanches were employed in similar activity in the European combat zone. But the Choctaws and Comanches conversed in their native tongues. The Navajos, on the other hand, developed a special coded alphabet of 38 symbols plus an auxiliary vocabulary of 41 other terms. It's been described by anthropologists Henry Dobyns and Robert Euler as "absolutely unbreakable."

Skilled as the Japanese cryptographers were, it's doubtful whether they would have understood Navajo even if there had been no attempt to disguise it. At that time it was virtually an unwritten language and even today few non-Navajos have succeeded in mastering its complex glottal sounds and vowel tones.

But rather than take a chance the Navajo code talkers improvised a system substituting clan names for military units, the names of birds for airplanes and fish for ships, plus a double alphabet when it was necessary to spell out proper names. The idea originated with a Navajo-speaking white man, Philip Johnston, an engineer with the city of Los Angeles who was raised on the Navajo Reservation where his father had been a missionary. During the first few months of the war, he suggested his plan to a high ranking Marine Corps officer. It was approved after five Navajos demonstrated its possibilities to Marine brass.

By April 1942, Marine Corps recruiters arrived at the reservation searching for Navajos who were physically fit as well as fluent in Navajo and English. The first group of volunteers, 29 youngsters from various boarding schools in Arizona and New Mexico, were sent to boot camp at San Diego. From there they were transferred to the Field Signal Battalion at Camp Pendleton, then assigned to Marine combat divisions throughout the Pacific.

Philip Johnston joined the Marines in the fall of 1942 and was put in charge of the code talker training program. Eventually some 320 Navajos served in combat under the program. Martin Link, curator of the Navajo Tribal Museum who is compiling records of the code talker experience, recently learned that four or five Navajos served in a similar capacity with the Army in North Africa, although details of that episode remain sketchy. In fact, information about the Marine Corps code talkers has only recently come to light.

The code talkers served in many campaigns, usually in two-man teams conversing by field telephone and walkie-talkie to call in air strikes and direct artillery bombardment. Marine Corps archives contain ringing praise for the Navajos from commanders in the field. It was exciting and dangerous duty, sometimes for unexpected reasons. William McCabe, one of the 29 original volunteers, was taken prisoner on Guadalcanal - by his own troops. Suspicious that the swarthy figure with the high cheekbones was really a Japanese soldier in a U.S. uniform, watchful Marines marched him at gunpoint back to his unit. From then on buddies in his unit assigned him a non-Indian bodyguard.

The idea for a formal association of code talkers grew out of the 1969 annual reunion of the Fourth Marine Division Association, which honored several of the Navajos. Two years later the Navajo Tribal Museum, the repository for Philip Johnston's papers and other code talker memorabilia, sponsored a two-day reunion. Now the Navajo Code Talkers Association numbers more than 100 members.

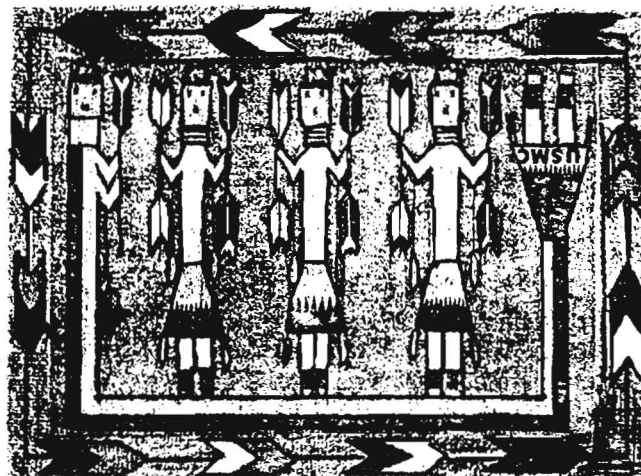

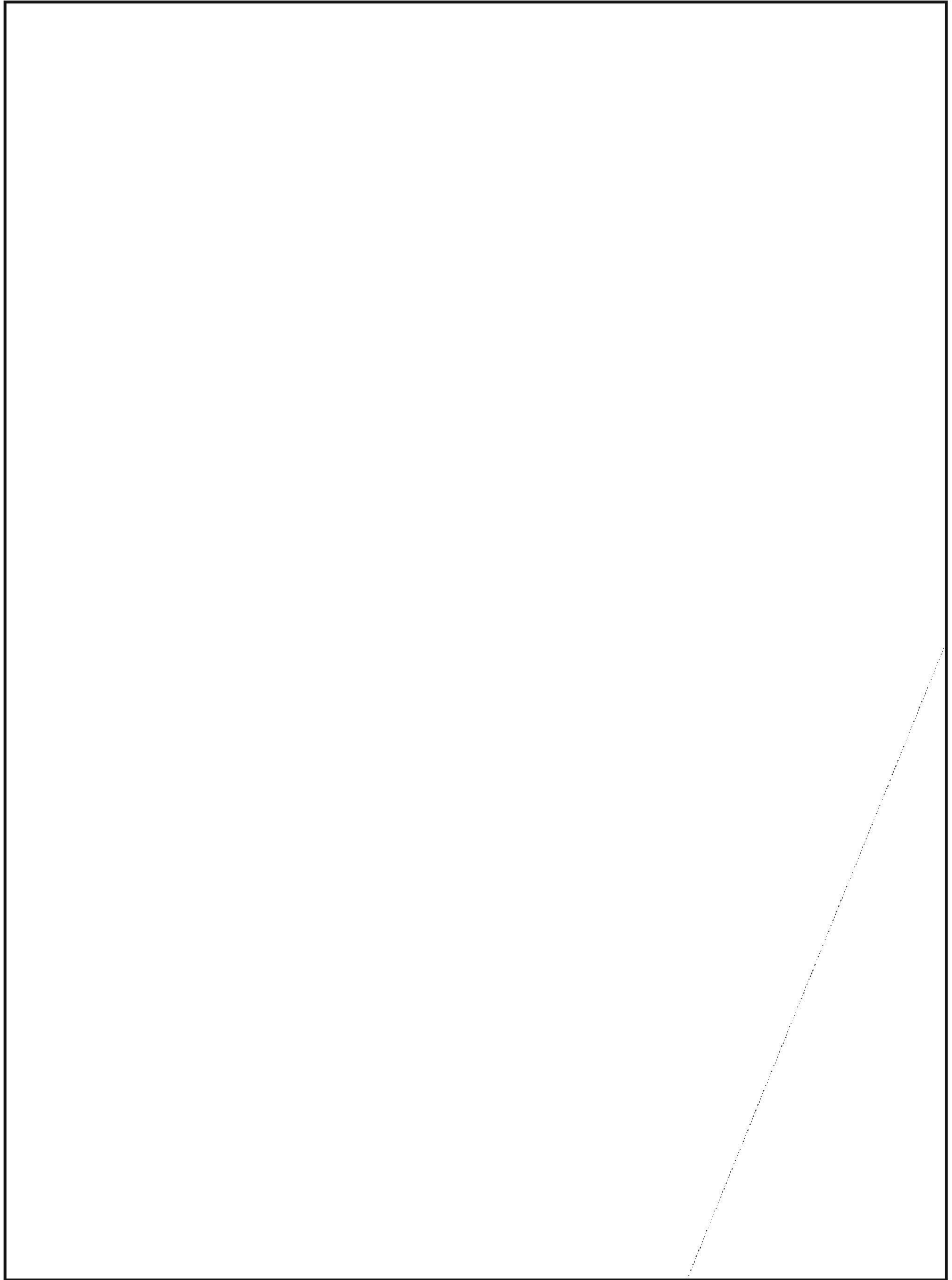

PROFESSIONALIZING IN COMPUTER SYSTEMS

What is a computer systems professional? *Webster's New World Dictionary* defines a profession as a "vocation or occupation requiring advanced education and training, and involving intellectual skills.." and a professional as one "engaged in, or worthy of the high standard of, a profession."

In reading about professionalism one finds most articles center around two areas: background and standards. Background covers education, training, and experience in a field. Standards center on requirements, legal or otherwise, required by a society for one to be called a professional in a particular field. In the fields of medicine and law we find society acceptance of the definitions for background and standards, but what about other fields that have not existed, as these two have, for hundreds of years? In the newer fields, such as computer science, the quest for professional status is slow and full of conflicts.

In the computer field, there are many societies representing the different segments, and this causes a great deal of conflict. The Data Processing Management Association offers the Certificate in Data Processing. Various societies, ACM for one, have offered suggested academic programs leading to certification. Currently, the Society of Certified Data Processors (SCDP) is attempting to formalize the requirements in this area by means of state legislation. NSA and other government agencies and businesses have their own professional programs. All these efforts are contributing to the growth of professional status for the computer field, but they also arouse a great deal of emotion and conflict as to what constitutes acceptable background and standards, and what group should be the accrediting professional society.

How is a professional recognized? I quote a concluding paragraph from Jack Valenti's article in the *Washington Post* of 11 September 1971:

"Let me sit at a table or in a discussion where decisions are to be made and I can tell you quickly and accurately who the professionals are in the room. Dazzling rhetoric, intensity, passion, all these are of some measurable worth, but oftentimes they are the outer garments of the nonprofessional. The pro is the man or woman who knows what the issues are, has untangled the crossing threads of logic and reaction, understands the facts cold, has already searched the detail, and can, because he or she has prepared the necessary homework, bring forth the suggestion that usually makes the most sense. The professional may not always be right, but his experienced instinct is more formidable than the fellow who does it all in blind faith."

By

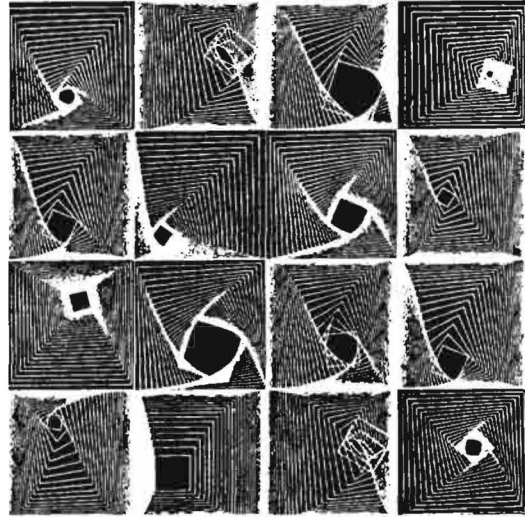

Computer drawing.

How does one become professionalized at NSA? The answers are contained in the memorandum, "Criteria for Certification (Computer Systems)" dated 4 January 1974 and available in the Panel Executive's office.

Obtain a copy of the criteria memorandum and review it. If you believe you are qualified, submit the necessary Professional Qualification Rating Schedule (PQRS) forms. Your background, experience, professional activity, and training are reviewed. Diversity of work experience, education and training, and professional activities and performance are assigned point values, as explained in the criteria, and the results of your initial evaluation are returned to you. If you are deficient in any area, you can intelligently plan your future to fulfill these requirements.

If 600 or more points are recorded, your records are forwarded to a three-peer professional review panel for what is described as a Qualitative Achievement Rating (QAR). The QAR panel is composed of one professional of your choice plus two panel appointees. A minimum of 200 points of the total 1000 required must be forthcoming from the review panel. During this period, if you have not previously written a scholarly paper in the computer field, you can do so under the direction of the Computer Systems Career Panel.

When you have completed a total of 820 or more points you can be scheduled for the Certification Examination. After accumulating 1000 or more points, writing an acceptable paper, and passing the exam, you are certified as a Computer Systems Analyst.

What is the Computer Systems Professional Qualification Exam (CSPQE)? It is a multiple-choice examination that attempts to measure objectively one's knowledge and awareness of the computer field and the computer environment at NSA. It is only a means of verifying the *other requirements* of professionalization as a Computer Systems Analyst.

The CSPQE has four categories: (1) Systems, (2) Applications, (3) Mathematics, and (4) General. The CSPQE test committee qualifies a question within each category as "NSA-specific" or "NSA-nonspecific." The question data bank is divided and identified into the four categories, with NSA specific and nonspecific qualifiers. (Questions are not identified by category on the exam itself.) Below is a matrix showing the current weighting for each category.

Category	Total Weight	NSA-Specific	NSA-Nonspecific
Systems	45	10	35
Applications	30	20	10
Mathematics	15	--	15
General	10	5	5
Totals	100	35	65

What this matrix says is that if 100 questions are used, 45 will be related to systems, and 10 of those will relate to specific NSA systems, such as TABLON. Information on such systems is obtainable from technical publications and lectures originating within NSA. The other 35 of the 45 should be answerable by anyone who possesses basic knowledge of the field and who keeps current with technical literature.

The SYSTEMS category consists of traditional computer-related topics such as hardware and software. Topics included are: language processors (assemblers, compilers, interpreters), language use/types (machine, procedure or problem-oriented), software engineering (top down design, structured programming), logic design, hardware components, computers (analog, hybrid, digital, mini- and micro-), operating systems, utility programs (I/O, maintenance, sort, merge), graphics and display technology, microprogramming, data communications, system evaluation and improvement (profiling and performance measurements) and programming techniques (sorting, merging lists, hashing techniques, etc.).

The APPLICATIONS category contains items on specific disciplines. Emphasis is placed on how applications are planned, guided, documented and accomplished. Some of the areas, items, and techniques covered by APPLICATIONS are: systems analysis (systems studies, feasibility studies, decision tables, PERT charts, documentation packages, records management, implementation procedures, data structures and file design, data security and application system evaluation

and improvement), business data processing (payroll, personnel records, inventory), education (CAI, CMI), CA, TA, languages and linguistics, TCOM, engineering and physical sciences, COMSEC, reporting transcriptions (project LAYAWAY), applications programming techniques, signals collection and signals analysis.

MATHEMATICS contains such topics as number systems, combinatorial and discrete math (including sorting, counting, permutations), statistics and probability, elementary algebra, Boolean algebra, numerical analysis (including error analysis and computer arithmetic), graphs, sets, coding, information theory, and meta-theory (including formal logic, automata, formal languages). The CSPQE tries to test whether an applicant has knowledge of the types of mathematics that enable him to function effectively as a computer professional (i.e., computer-related mathematics).

The GENERAL category is a catch-all for items that are difficult to place in one of the previous categories. It includes such topics as: history, philosophical and social issues, (privacy, government regulations and control of ADP), operations research, security (NSA security and how it impacts on NSA computer personnel), administration and management (computer operations management), simulation and modeling, and professional issues.

The examination is under the auspices of the Computer Systems Career Panel, which has a standing Test Committee of approximately five Agency experts. It is offered twice a year, in March and September, with the restriction that an aspirant may sit for the exam only once each calendar year.

The exam consists of 100 multiple-choice items. The committee uses a randomizing program to aid in the selection of test questions in an attempt to avoid slanting the exam toward the committee's technical bias. In order to validate new exam questions the test committee may scatter additional questions in the CSPQE. Examinees are given two hours to complete 100 items; this time is extended by an appropriate percentage for any additional questions exceeding 100. To preserve the validity of calculations on any "new" test items, examinees are not informed which items are for test and which are for validation purposes. The new questions which pass the validation process are added to the test question data bank.

During the exam, examinees are encouraged to write comments in the test booklet (not the answer sheet); grievances concerning an item will be considered by the test committee. When the exam is ended, each test item is reviewed by the committee with the aid of an item analysis program. This provides the committee with vital statistics concerning the reliability of the examination in general and the suitability

of specific items. All decisions regarding the examination are resolved without looking at the names of the individual examinees.

The passing score is 55 percent. The scoring algorithm is $R-W/3$, where R is the number of items answered correctly and W is the number answered incorrectly; so that wild guessing is counterproductive. Results are announced approximately five working days after the examination.

What reference materials should be read? Sources of information for studying for the CSPQE are found in books, periodicals, reports and special studies, courses, seminars, professional society conferences, and lectures. In selecting materials for review it should be remembered that the exam tests the understanding and recognition of basic principles--breadth, not depth, of knowledge is stressed. For example, one is expected to know how lists work and are used rather than to code a complicated program using lists.

Excellent articles and books have appeared in increasing numbers since the early sixties. Currently, several abstract and bibliographic publications are devoted to technical material related to computers. Rather than spell out specific textual references for each of the categories on the CSPQE, which may be quickly outdated or result in "tunnel vision" in this rapidly-changing field, it is better to point out where to find related technical material. The Technical Library at NSA contains more than enough literature from which one can become an expert in any one of the exam categories. One *must* learn to use the library and learn how to scan for information in texts and periodicals. One good technique is to use the table of contents to choose areas of study that enhance your background. Do not merely plod through books without having established goals concerning what you wish to learn.

If time permits, courses are an excellent way to assimilate new material. A review of computer courses offered by local universities, community colleges, and the National Cryptologic School (NCS) reveals that a wealth of information is available. The most convenient is the NCS.

Some of the appropriate NCS courses for each category on the CSPQE are listed below.

SYSTEMS

- MP160 Introduction to Computer Science
- MP2xx Any of the "computer-independent" languages available at NSA (FORTRAN, PL/I, COBOL, etc.)
- MP3xx Any of the "computer-dependent" languages available at NSA (IBM's ALC and JCL, CDC's COMPASS, Univac's Assembler, DEC's DOS and RSXIID, etc.)
- MP1xx Any of the information storage and retrieval languages available at NSA (Model 204, TILE, SPECOL, etc.)

- MP4xx Any of the seminar courses or software evaluation courses
- MP410 Introduction to Computer Hardware
- MP420 Introduction to System Software
- MP430 Programing Techniques

APPLICATIONS

- CY120 Survey of Cryptologic Skills and Techniques
- EA100 SIGINT Technology
- TA100 Basic Traffic Analysis
- CA105 Introduction to Cryptography and Exploitation of Manual Cryptosystems (self-study, available through the Learning Center)

Any other specific disciplines

MATHEMATICS

- MA012 Algebra (self-study texts)
- MA111 Algebra (self-study texts)
- MA144 Probability and Statistics
- MA103 Introduction to Formal Logic
- MA400 Introduction to Computer Science Mathematics

GENERAL

- MP060 Survey of EDP
- MC120 Cryptologic Management for Supervisors

In addition to formal help or information, you can get help from fellow professionals and from the many help/study sessions sponsored by the various offices within the Agency.

People have voiced both praise and criticism for the NSA Professionalization Program and for the recent changes to the criteria for certification. It can be pointed out that we do not live in a static society. Even in the medical area, one of the oldest professional groups, there is change afoot, as evidenced by recent controversies over heart transplants and acupuncture. NSA is a highly technically-oriented agency. Training at NSA, and by universities and vendors, is encouraged. The main ingredient needed by an NSA employee who has the ability to attain professional status is dedication: real interest in his field, and a willingness to devote time to the pursuit of his career.

For people not associated with NSA, the expenditure of personal time and money for professional status can be considerable. For example, the fee for the CDP exam, now administered by the Institute for Certification of Computer Professionals, is \$85. To retake the entire exam or failed sections requires additional expenditures, and to take the review courses for the exam is additional expense. We at NSA are fortunate to have a defined and accepted professional program, where monetary requirements are minimal and where one is given both opportunity and encouragement to be recognized as a professional.

Reprinted from the December 1974/
January 1975 issue of **C-LINERS**

TOP SACRED PROJECT SYMBIOSIS

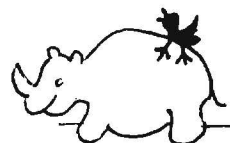

I was recently accused of being a founder of the Church of the Latter Day Luddites, but I'm not. True, at times I've felt like John the Baptist crying in the wilderness. It's not that I dislike machines so much -- I guess that they have their place, but they think they know it all. To me there is little difference between a machine with one moving part and our most sophisticated computers. I've never been able to intimidate my car by kicking the tires. It only gets vindictive. This attitude, I realize, borders on paranoia, but the time has come. Those of us who are left must speak out. The line between humanism and mechanism must be clearly drawn!

My greatest concern is not that machines will communicate with each other and take over, but that their language and logic processes are becoming commonplace among us humans. Have you noticed the kinds of words we're using these days? Words either devoid of emotional content or slightly misused. I'm not talking about "irregardless" for "irrespective," but words having no literal meaning in the context in which they appear. Sometime check out the real meaning of *viable*, *interface*, *syndrome*, *feasible*, *mandate*, *parameter*. . .

Although word usage is, I suppose, not truly indicative of personality traits, we do seem at times to talk and write like unthinking automata. And yet the purpose of human speech and writing -- the paragraph, the sentence, and, yes, even the individual word -- is to convey meaning. At least I always thought so. If you don't believe that, it's only an indication of the extent to which machines have already debased our natural subjective and emotional human instincts. Our machine-oriented environment tries, through all its media, to make us omit the subjective, omit the "superfluous" human element. In order to fit our answer into the keypunch holes allowed, we must be more "objective," more "concise," more "with it." And, in order to be more "with it," we tend to use the "in words," regardless of their meaning or appropriateness.

The other day, when I expressed these views, I was challenged. "Of course we're all right," my companion said. "How could machines take over? You've really got a thing about those inert pieces of equipment." The gauntlet having been flung, I decided to write a short piece that would be understood by a machine and that, in addition, would probably get an instinctive nod of approval from a large percentage of the people in the Agency. Not because they understood it, but because they couldn't convince themselves that they didn't.

Take the following paragraphs of a draft report:

Based on integral subsystem considerations, Project SYMBIOSIS is designed to provide a large portion of the interface coordination communications needed for automatic text processing. In respect to specific goals, a constant flow of effective information must utilize and be functionally interwoven with the evolution of specifications over a given period of time.

A primary interrelationship between system and/or subsystem technologies presents extremely interesting challenges to the anticipated fourth-generation equipment.

In particular, the characterization of specific criteria maximizes the probability of project success and minimizes the cost and time required for the subsystem compatibility testing. On the other hand, the initiation of critical subsystem development requires considerable systems analysis and trade-off studies to arrive at the total system rationale and the fully integrated test program necessitates that urgent consideration be applied to the philosophy of commonality and standardization.

All right, now, be honest. Wouldn't 60 percent of the people in the Agency have initialed the above garbage? And yet, except for the first sentence, it was "generated" randomly from the "Simp tables" printed on the next page.

If human beings respond to this sort of stuff, so do machines. In fact, a programmer's software toy called DREKGEN can grind it out in any volume desired. Here is a sample output:

PHILOSOPHY OF PROGRAMMER MANAGEMENT

WITH A VIEW TOWARDS THE SOLUTION OF CERTAIN DIFFICULTIES TRAINING PERSONNEL, INSTRUCTORS AND SUPPORT PEOPLE ORDINARILY COULD BE EXPECTED TO MINIMIZE EDUCATIONAL EFFORTS TO OPERATORS. AS REQUESTED BY HIGHER MANAGEMENT MIDDLE LEVEL MANAGERS ORDINARILY COULD BE EXPECTED TO MINIMIZE EXPANSION AND IMPROVEMENT OF WORK AREAS. SENIOR DATA PROCESSING MANAGERS, WHILE SEEMINGLY PASSIVE, ARE QUITE CONCERNED ABOUT PLANS TO ENHANCE TESTING AND PROPER CATEGORIZATION OF PROFESSIONALS. ON THE BASIS OF INDEPENDENT STUDIES, THE LESS THAN ADEQUATE EMPLOYEES MUST STRIVE TO AVOID TRYING TO ENHANCE ROTATION AND REASSIGNMENT O

F SUBJECT PERSONNEL. THOSE WHO WORK WEEK ENDS AND ALL SHIFT WORKERS ARE BELIEVED TO BE OPPOSED TO ANY EFFORT TO REJECT ROTATION AND REASSIGNMENT OF SUBJECT PERSONNEL. AS REQUIRED BY DIRECTIVE OR REGULATION TRAINING PERSONNEL, INSTRUCTORS AND SUPPORT PEOPLE ARE BELIEVED TO BE OPPOSED TO ANY EFFORT TO RECALL FOR REDESIGN AND FURTHER ANALYSIS RETRAINING OF OBSOLESCENT PERSONNEL. THE LESS THAN ADEQUATE EMPLOYEES DESPITE PERSONAL RESERVATIONS SHOULD TRY TO OBIVIATE ROTATION AND REASSIGNMENT OF SUBJECT PERSONNEL. AS REQUIRED BY DIRECTIVE OR REGULATION THE REALLY BRIGHT WORKERS, THE INNOVATORS, MUST STRIVE TO AVOID TRYING TO INCREASE REDEFINITION OF CERTAIN TASKS, PROJECTS AND AREAS OF ASSIGNMENT.

I ask you, have we been subverted?

If any of this has caused you to think twice, then join us. We ask only that language be used to convey meaningful ideas, not to obfuscate or to demean our capacity to co-exist with the UNIVAC-1110 and the electric light bulb.

I realize that machine feedback is insidious (and insipid), spreading like the reams of paper it produces. Still, just because we can't beat them, that doesn't mean we must join them. Let the machine serve our better interests. There is no need for us humans to adopt the machine's idioms. I'd much rather retreat into the English language than submit to fluency in FORTRAN.

Anonymous (but those @*#! machines know my number: 016 22 723A)

DEPARTMENT OF GOLDEN OLDIES

The reader who submitted the following item picked it up at GCHQ in 1971 but does not remember who originated it. No one here, including UKLO people whom we asked, knows anything about it, or even what "Simp" means. Does any reader have any more details?

The "Simp tables" are so designed that the writer can choose phrases randomly from Tables A, B, C, and D in sequence (or, for variety's sake, from B, C, and D) to create sentences that look valid, but are entirely devoid of meaning. Try your hand at it! Fool your friends! (To make your phony sentences look less suspect, we have changed British spellings with "s" to American spellings with "z.")

Simp Table A

1. In particular,
2. On the other hand,
3. However,
4. Similarly,
5. As a resultant implication,
6. In this regard,
7. Based on integral subsystem considerations,
8. For example,
9. Thus,
10. In respect to specific goals,

Simp Table B

1. a large portion of the interface coordination communications
2. a constant flow of effective information
3. the characterization of specific criteria
4. initiation of critical subsystem development
5. the fully integrated test program
6. the product configuration baseline
7. any associated supporting element
8. the incorporation of additional mission constraints
9. the independent functional principle
10. a primary interrelationship between system and/or subsystem technologies

Simp Table C

1. must utilize and be functionally interwoven with
2. maximizes the probability of project success and minimizes the cost and time required for
3. adds explicit performance limits to
4. necessitates that urgent consideration be applied to
5. requires considerable systems analysis and trade-off studies to arrive at
6. is further compounded, when taking into account
7. presents extremely interesting challenges to
8. recognizes the importance of other systems and the necessity for
9. effects a significant implementation of
10. adds overriding performance constraints to

Simp Table D

1. the sophisticated hardware.
2. the anticipated fourth-generation equipment.
3. the subsystem compatibility testing.
4. the structural design, based on system engineering concepts.
5. the preliminary qualification limit.
6. the evolution of specifications over a given time period.
7. the philosophy of commonality and standardization.
8. the greater flightworthiness concept.
9. any discrete configuration mode.
10. the total system rationale.

~~CONFIDENTIAL~~

LETTERS TO THE EDITOR

To the Editor, CRYPTOLOG:

With reference to the complaint [See Letters to Ed., Apr 75] that "bookbreakers" were discriminated against in the professionalization program, it seems to me that the persons most discriminated against are those who are or were what I would call "country specialists." I don't know where else the system existed,

[redacted] at least, was assigned to country analysts who for their areas would scan plaintext, [redacted]

[redacted] make intelligence evaluations, and translate or report, as the occasion demanded, the traffic selected by themselves. Quite often they even had to log their own traffic.

In pre-professionalization days these people were given no recognition, pecuniary or otherwise, by the rest of the Agency for their versatility. With the coming of the professionalization program, they were even penalized because they had not specialized in a fraction of what they were doing.

[redacted]

Ed. note: [redacted] G514 informs us that, since he is professionalized both in the language field and in the SRA field, he has no personal grievance, but seeks only to achieve a more equitable situation in the system as a whole.

To the Editor, CRYPTOLOG:

I take serious exception to [redacted] cavalier dismissal [See Letters to Ed., May 75] of what is, after all, the basic SIGINT skill as no more than a preliminary scrubbing of traffic before the real analyst -- the bookbreaker --



EO 1.4.(c)
P.L. 86-36

[redacted]

[redacted]

It's praiseworthy to be loyal to one's profession, to one's own mission. Belittling the profession of those who do not share one's views on a given subject is hardly the way to convince an audience of the rightness of those views. It is more likely to convince that audience of the biased and nonprofessional outlook of the person who states them.

(Name withheld by request)

P.L. 86-36

To the Editor, CRYPTOLOG:

I would like to express my appreciation to [redacted] for his most effective statements in the April 1975 issue of CRYPTOLOG on our agency's need to develop a human medium for dissemination of our product. Although his statement of the need for oral reporters was well made and his suggestions for the development of oral-reporting props was most informative, there was one aspect of the article which I found lacking -- where do oral reporters come from?

In differentiating oral reporters from "briefers" the main theme developed by Mr. [redacted] seems to be that oral reporters know what they are talking about. Unfortunately, within our agency (and the world at large, for that matter) people who know what they are talking about are at a real premium. All the mechanical, audio-visual techniques which enhance oral reporting can, with proper emphasis, be taken care of. The high-level exposure which oral reporting offers relatively junior-grade employees should be a considerable career incentive which would make an oral-reporting assignment attractive. The crux of the oral-reporting problem is not the discovery, development, and motivation of people with the physical and emotional attributes necessary in an oral reporter. The problem is finding people who are genuine experts.

While the present career-development system in NSA may not offer the proper incentives to "briefers," it offers even fewer incentives for people who develop into experts on a given target. In current career-development patterns, diversification has become an obsession. The stable in-depth human data bases (little ol'

people in tennis shoes) who have been the mainstay of the agency are now held in contempt, are rapidly disappearing, and are not being replaced. "Management" now appears to be the greatest virtue for rapid rise in the agency. The smart young FSG (future super-grade) certainly does not want to become stereotyped as an expert on some particular problem for fear of becoming "an invaluable human resource" stagnated at one grade forever.

[redacted] mentions in his article the "same few people" who always go downtown. Obviously we need more of them. We need more people who are real authorities, but in my experience there are very few middle managers in the agency who have had any desk-level analytic experience within the actual problems that they are managing. Frequently there are lower-grade analysts within their organizations who know more about the given problem than does the chief of the element. In this situation there is little incentive for a lower-grade analyst to develop himself or herself into a real expert. The prime goal of career development is to get out before you get stuck (the intern program, CY-100, a staff job). I believe that these are aspects of agency career development that must be seriously reassessed. Soon we may become an agency of managers, managing nothing. While avoiding overspecialization the agency must somehow place a premium on, and develop, specific problem expertise within the work force. If we have more people within the work force who really do know what they are talking about, then the development of oral reporters will take care of itself.

P.L. 86-36

NSA VIETNAM WRAP-UP

The entire October issue of CRYPTOLOG will be devoted to the Vietnam War and its significance to NSA -- achievements, failures, lessons learned, problems unresolved. The Editorial Board invites contributions from readers for possible inclusion in that special issue. Send contributions to Editor, CRYPTOLOG, P1 by 15 August 1975.

If you have valuable information to impart, but feel that you need help in getting it on paper, please get in touch with any of the members of the Editorial Board. We will try to think of a way to get your information into that issue -- perhaps by transcribing your tape-recorded remarks, question-and-answer interview, etc.

Memo from

Chief, PI

3 June 1975

Doris Miller, the first editor of CRYPTOLOG, retires this month. She was much more than the Editor -- she brought CRYPTOLOG along from a flight of our fancy, through frequent and troublesome growing pains, to the lusty, squalling youngster it is today. Of course she had help -- not as much as she needed, but lots of it. All of us connected with this publication know it could not have been brought off successfully without her.

Doris Miller's uncommon good taste, her instinct for newsy and readable subject matter, her gift for persuading people to write "just a little -- even a page or two," and, above all, her indomitable spirit in the face of obstacles were the talents needed to bring CRYPTOLOG into being.

Eighteen months ago she advocated a publication in DDO, written by technicians for technicians, informal, newsy, controversial, lively and timely, to be published -- would you believe -- every month. This issue of CRYPTOLOG puts the capstone on the uncommonly productive NSA career of Doris Miller.

We wish her a busy, productive retirement and the joy of facing each new date with never a worry of deadlines. Doris, we'll miss you!

William Lutwiniak
 Publisher
 CRYPTOLOG

The power of the comma! A few weeks ago I accepted Doris's offer to become Art Editor, and one week later I became Art, Editor.

As thoughtful of others as she has always been, Doris had roughed out the June issue before announcing her intention to retire. Therefore I was able to rely on Doris many times for guidance as the issue got de-roughed-out. If there is anything about this issue that you like -- the articles, the layout, etc. -- thank Doris. If there is anything about future issues that you like, it will be largely because of the fine start that Doris has given CRYPTOLOG and also because of the continuing support given to it by Mr. Lutwiniak, by the editorial board, and especially by CRYPTOLOG's ever-growing and ever-responsive readership. I hope that I can be as successful as Doris has been in getting you NSA technicians to share your best ideas with your fellow NSA-ers in all technical fields, at all levels.

Art,

~~TOP SECRET~~

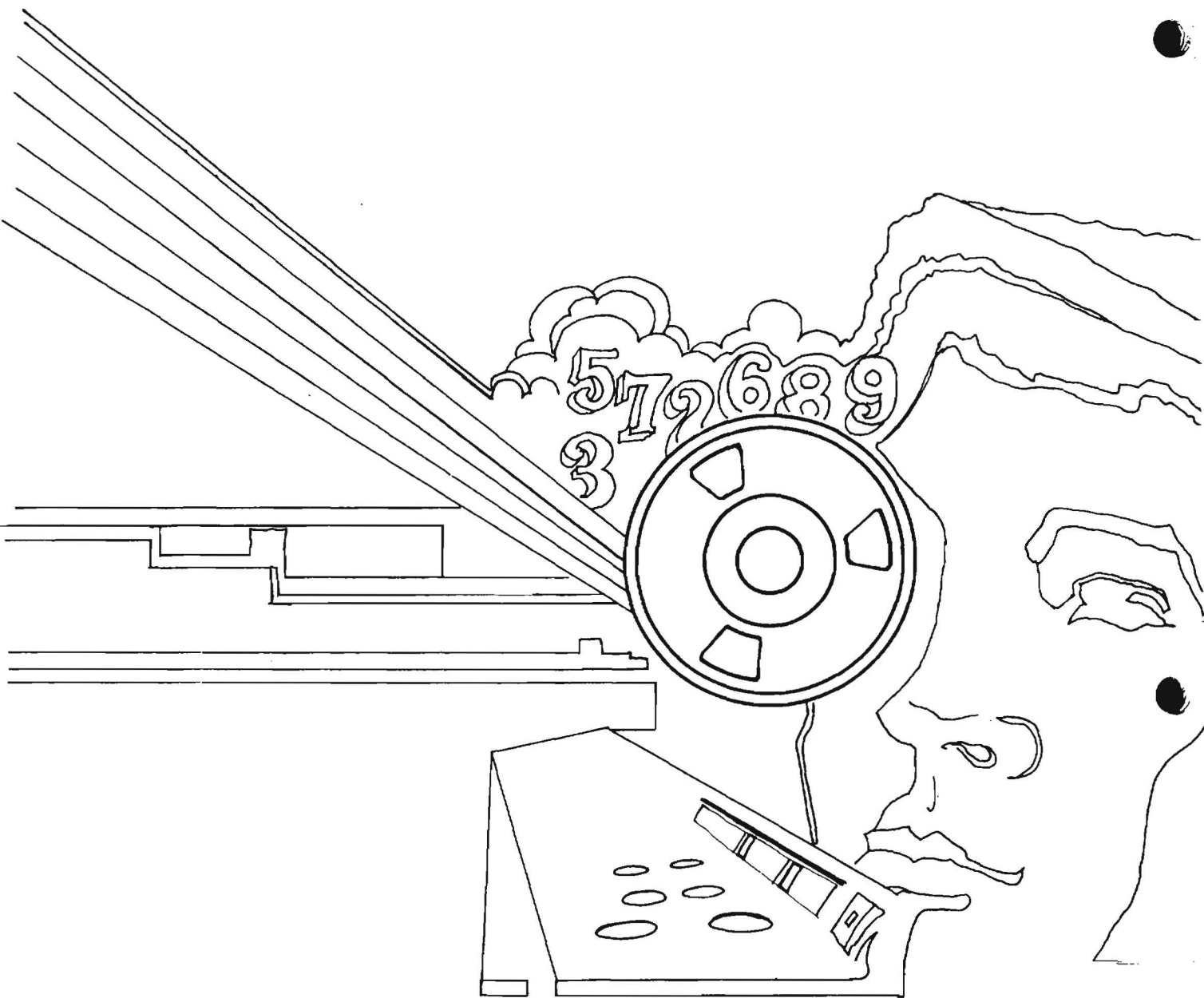

~~THIS DOCUMENT CONTAINS CODEWORD MATERIAL~~

~~TOP SECRET~~