

ALL HANDS

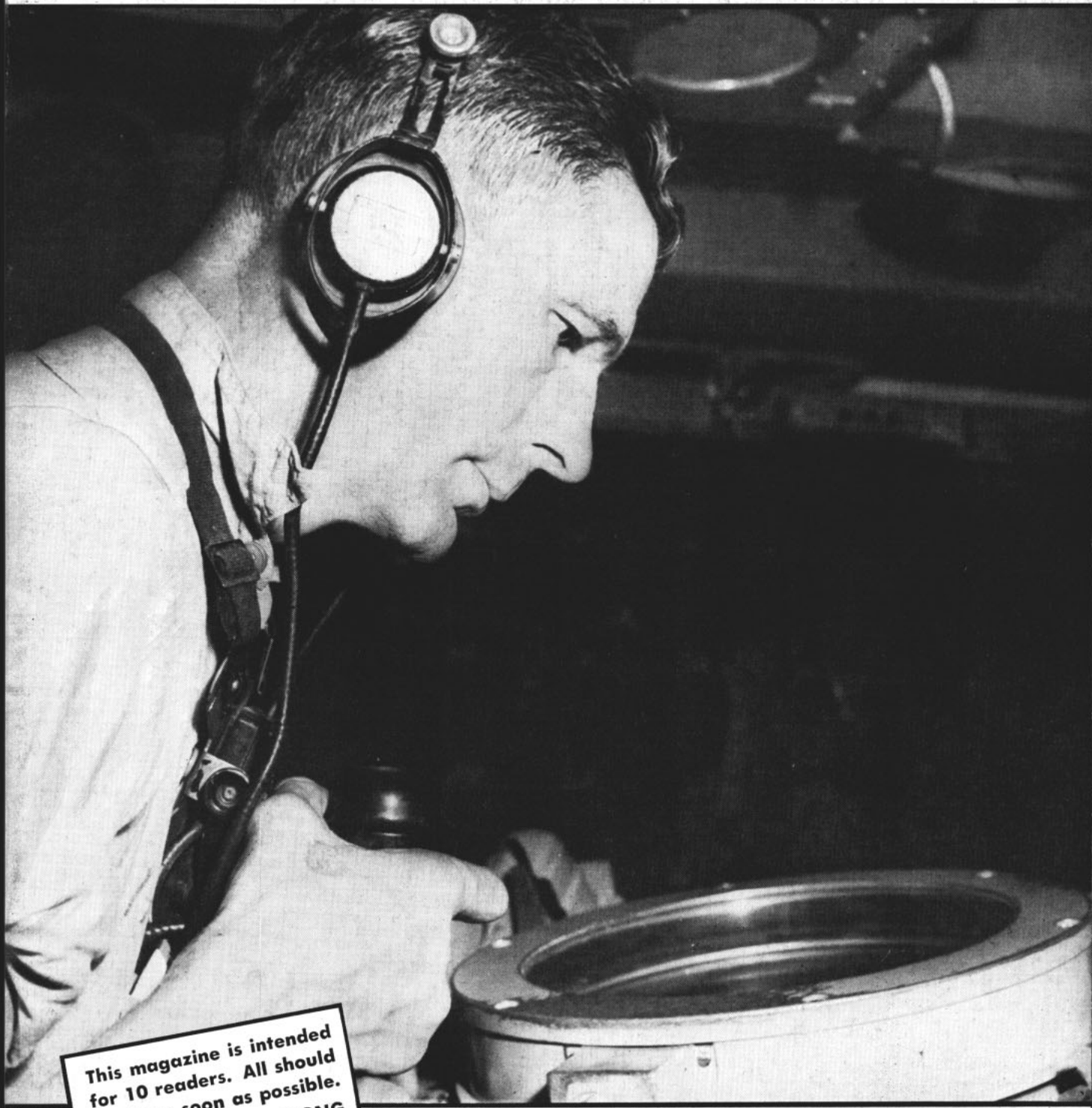

This magazine is intended
for 10 readers. All should
see it as soon as possible.
PASS THIS COPY ALONG

DECEMBER 1959



ALL HANDS

THE BUREAU OF NAVAL PERSONNEL INFORMATION BULLETIN

DECEMBER 1959 Nav-Pers-O NUMBER 515

VICE ADMIRAL H. P. SMITH, USN
The Chief of Naval Personnel

REAR ADMIRAL A. E. LOOMIS, USN
The Deputy Chief of Naval Personnel

CAPTAIN F. R. WHITBY, Jr., USN
Assistant Chief for Morale Services

TABLE OF CONTENTS page

Summer Wonderland	2
TV on Ice	7
ETs and ENs: GCA's Forgotten men.....	8
Flying Trailers	11
Amphib Assault Ship	12
"... above and beyond the call ..."	14
Sailor's Museum	19
18 Years Later —	
Visitors Pay Tribute to Crew of USS Arizona....	20
Those Were the Days	22
Supermarkets at Sea	24
Letters to the Editor	25
Spanish Minemen	31
Centerspread:	
Veterans Benefits Based upon Type of	
Discharge	32
Today's Navy	34
Sailing Islands	41
Servicescope: News of Other Services	42
The Word	44
Bulletin Board	46
How to Request Duty to New Construction	46
Here are the Factors Deciding	
Whether You Will Draw Pro-Pay	48
If You're Eligible for Recruiting Duty	
This May Interest You	50
Ever Heard of Eleuthera? It's a Good	
Example of Island Duty	52
Get Hot on Your Deep Freeze Applications	54
Pointers for Career Men Using Korean G.I. Bill	55
Rules on Transfer of Reservists to USN	56
Decorations and Citations	58
Special Supplement:	
Seapower Turns the Tide—1781	59
Taffrail Talk	64

CDR F. C. Huntley, USNR, Editor
John A. Oudine, Managing Editor

Associate Editors
G. Vern Blasdell, News
David Rosenberg, Art

Elsa Arthur, Research
French Crawford Smith, Reserve
Don Addor, Layout

● FRONT COVER: SCOPE OF IT—Radarman L. P. McLawhorn, RD1, USN, follows the track of an air contact as USS Pillsbury (DER 133) patrols the Atlantic barrier.

● AT LEFT: PLEASANT PAUSE—Ships of the Sixth Fleet drop anchor off shore at Rhodes, Greece for enjoyable break in shipboard routine during operations in the Med.

● CREDITS: All photographs published in ALL HANDS are official Department of Defense Photos unless otherwise designated.





SUMMER WONDERLAND

ANTARCTIC RESUPPLY FORCES began leaving U. S. seaports and airfields early this fall in support of the United States Antarctic Research Program.

Eight ships, three dozen aircraft and some 3000 men will be involved in the operation, code-named Operation Deep Freeze 60. (Four previous expeditions were called Operation Deep Freeze I, II, III and IV, but the identifying number was changed this year to coincide with the fiscal year—July to July—the time span of each operation. Next year's operation will be Deep Freeze 61.)

The ships include icebreakers, cargo carriers and an oiler. The planes range from the Navy's ski-equipped R4D *Skytrains* to the Air Force's C-124 *Globemasters* and ski-equipped turbo-prop C-130 *Her-*

cules. The C-130s will be used for the first time in Antarctic operations.

Primary mission of Deep Freeze 60 is to continue support of the U. S. Antarctic Research Program (USARP) which is administered by the National Science Foundation. This means bringing in new personnel and fresh supplies for four American Antarctic scientific stations which are being maintained indefinitely, supporting summer scientific efforts, and constructing new buildings to increase livability and scientific projects.

THE FOUR U. S. STATIONS operating on a year-round basis are: *South Pole Station*, located at the geographical pole almost 10,000 feet above sea level; *Naval Air Facility McMurdo Sound*, principal cargo

staging base for the operation as well as a limited scientific station, located on the west coast of the Ross Sea; *Byrd Station*, in the heart of Marie Byrd Land; and *Hallett Station*, on Cape Hallett in the Ross Sea, which is jointly supported by New Zealand and the United States.

Two seasonal auxiliary air facilities for summer support of flight and field operations will be set up. One will be at the foot of the Beardmore glacier (NAAF *Beardmore*) and one at the half-way point between NAF McMurdo and Byrd Station (NAAF *Little Rockford*). In addition, *Little America V*, on the edge of the Ross Ice Shelf, will be used to salvage equipment.

A second mission has been assigned to ships of Operation Deep Freeze 60. Two icebreakers, uss

Glacier (AGB 4) and *uss Burton Island* (AGB 1), will attempt in February to penetrate to the Bellingshausen-Amundsen Sea coasts to obtain oceanographic, cartographic and geographical data of that area. Located on the side of the continent below South America, the Bellingshausen-Amundsen Seas are heavily clogged with ice for most of the year and have never before been navigated by ships.

THE WINTER POPULATION at the four main stations is 191. Twenty-eight of these are scientists and the remainder naval officers and men.

Summer operations will wind up in early March 1960 when another group of Americans will remain in Antarctica to winter over. (Remember, when it's winter up here it's summer down there.)

Planes of the Navy's Air Development Squadron Six (VX-6) from Quonset Point, R. I., and the Air Force's Ninth Troop Carrier Squadron from Donaldson Air Force Base, Greenville, S. C., commenced flying in to McMurdo about 1 October.

Ships of Task Force 43 will begin their unloading and loading operations in Antarctica on or about 10 December. They will all stage through New Zealand ports.

Summer Station Operations (October—March)

South Pole: *Globemasters* began air-dropping 650 tons of equipment, drummed fuel, aviation gasoline, provisions, and other supplies about 1 November. The largest item to be air-dropped is a 16,000-lb D-4 tractor. The tractor is needed to prepare a runway in February for landing C-130 planes which will bring in new buildings for Pole Station. Five buildings are scheduled for construction.

Seventeen men who have been wintering over at the South Pole were to be relieved in late November and flown out to McMurdo and then to the United States. Their reliefs will be flown in by planes of VX-6, which will also carry items of equipment considered too delicate to air-drop.

Byrd Station: Cargo planes began the air-drop at Byrd Station in mid-October, depositing approximately 800 tons of supplies, fuel and provisions. In late December a tractor train from Little America will arrive at Byrd Station with heavy equipment and two new buildings. In



AS ANTARCTIC SUMMER approaches, Navy ships and men again set courses in general direction of South Pole. Operation Deep Freeze 60 is underway.

February, Air Force C-130s will deliver two more buildings.

Hallett Station: The cargo ship *uss Arneb* (AKA 56) is scheduled to arrive at Cape Hallett with an icebreaker escort in early January to off-load supplies and equipment. It will be an amphibious operation. The wintering-over party was flown out earlier. No new construction is planned for Hallett Station.

NAF McMurdo Sound: Navy Seabees will again prepare a runway

6000 feet long on the bay ice of McMurdo Sound. The 90-ton *Globemasters* will load cargo on this strip for the air-drops at Pole and Byrd Stations. The Seabees will also prepare an emergency runway on the ice in the Marble Point area before the season's operations.

The icebreaker *uss Atka* (AGB 3) will arrive at McMurdo on 10 December and commence preparing a channel and off-loading site. *Arneb*, after picking up heavy vehicles at

ALL THE TRIMMINGS—Navy men at Ellsworth Station take time out to enjoy their Thanksgiving dinner as chief cook E. H. Davis dishes out the turkey.





CLOSE SHAVE—Navy supply sled has close call with crevasse as scientific team moves to study interior. Unloaded sled was pulled out by sno-cats.

Little America, will arrive at McMurdo about 15 December in company with *Glacier* to begin off-loading.

All of the 135 men who wintered over at McMurdo are back in CONUS, in time for Thanksgiving turkey—and a white Christmas.

A major construction program is planned for McMurdo this year. Slated to go up are three 250,000-gallon fuel storage tanks, four barracks buildings, a hangar foundation,

two communications buildings, a garage, three storage buildings, a fire house, two scientific buildings and three general purpose buildings.

Navy Air Development Squadron Six (VX-6): VX-6 aircraft departed the United States to be in New Zealand by mid-September, to prepare for the first fly-in to Antarctica about 1 October. The 21-plane squadron is air-lifting personnel and light cargo to the various Antarctic stations and will carry supplies to

Navy tractor trains and USARP science traverse parties. They will also make reconnaissance flights ahead of tractor and traverse parties to locate rough terrain and dangerous crevassed areas.

Their long-range planes will fly photographic missions over previously unmapped areas. The squadron will additionally be responsible for search and rescue operations in Antarctica. Except for SAR requirements, planes of VX-6 will not fly into the Antarctic until the Air Force has completed most of its air-drops because of the crowded conditions at McMurdo. The R7V will ferry passengers and cargo between New Zealand and McMurdo, however.

Air Force Participation: Ninth Troop Carrier Squadron (Heavy) *Globemasters* will carry out a variety of missions for Deep Freeze. The ten planes have been air-lifting personnel and priority cargo from the ice of McMurdo Sound, making round trips to Pole and Byrd Stations, dropping upward of 10 tons of cargo per trip. Air-drop operations were to be completed this month.

Two *Rescuemasters* will stand by in Christchurch for SAR operations between New Zealand and Antarctica.

Four Air Force *Hercules* will

COOL CEREMONY—Sno-cats and other Antarctic vehicles pass in review to honor departure of RADM G. J. Dufek.



make their Antarctic debut in February. Developed by the Air Force for use in Arctic regions, the *Hercules* can carry the payload of a *Globemaster* (10 tons) and has the added capability of landing on skis on snow runways. The turbo-prop planes are being called in to transport to Byrd and Pole Stations buildings and materials which will not arrive in Antarctica until after the normal flying season for wheeled aircraft.

Ship Operations

Captain Edwin A. McDonald, USN, Deputy Commander of Task Force 43, is in command of the ship group consisting of four icebreakers two cargo ships, one tanker and a destroyer escort picket ship. His ships carry the supplies necessary to maintain the four American bases for the next year, as well as the aviation gasoline required for operations.

The ships will also act as ocean station vessels to support aircraft flying between New Zealand and the Antarctic. *uss Peterson* (DE 152) maintains station about halfway between New Zealand and McMurdo (60°S—170°E) for the benefit of all aircraft making the 2100-mile over-water flight. *Peterson* is based in Dunedin, New Zealand.

In February, Captain McDonald will take two icebreakers through the ice pack to make the attempt to reach the Bellingshausen and Amundsen coasts.

The Little America - Byrd Station Tractor Train: On or about 15 December a heavy equipment tractor train is scheduled to depart Little America for Byrd.

Carrying supplies, fuel and provisions to make it self-sustaining, the train is a means of getting heavy equipment to Byrd Station for use in recovering air-dropped supplies and for leveling a runway.

One of the train's D-8 tractors will be left at Little Rockford on the way out. Personnel of the train will be flown back to McMurdo.

Victoria Land Traverse: A party of scientists left NAF McMurdo-Scott Base (New Zealand Base) in late October and proceeded up the Skelton Glacier to the Victoria Land Plateau, a vast, desolate, ice-capped expanse of 7000 to at least 9000 feet in elevation.

Their plan called for them to proceed in a northwesterly direction into the interior of the continent



BREAK THROUGH—USS *Glacier* (AGB 4) breaks out Norwegian sealer that was icebound over five weeks while taking Belgian expedition to its base.

to a point about 74°S—140°E, from there to turn northeast to the Hallett Station area. Seismic gravity and glaciological studies will be made throughout the traverse and topographic control provided at such places as the party encounters mountainous terrain. The traverse is being supported by R4D fuel-caches placed at the top of the Skelton Glacier and will receive a *Globemaster* air drop about the first of this month. Vehicles will be left at the top of the Tucker Glacier (near Hallett Station) for later use and the party will be returned to

McMurdo by R4D aircraft.

Marie Byrd Land Traverse: This party, equipped with three or four Snocats, left Byrd Station last month for a 1200-mile traverse that will take the party to the outer Marie Byrd Land coast near the Amundsen Sea and to the Executive Committee and Hal Flood Mountain Ranges where geological and geodetic studies will be conducted.

The party will then travel south to the Army-Navy Drive (trail between Little America and Byrd) at about Mile 200 and return to Byrd Station. It is expected that this party

DIG THIS—Navymen go about the task of digging out aircraft snowed in by storms of the Antarctic winter as they prepare for the summer's activities.





INTERNATIONAL FLAVOR—Navy captain, E. A. McDonald, CO of task group, chats with leader of Belgium polar expedition and skipper of Norwegian ship.

will be in the field until early February.

Airborne Traverse: An airborne traverse consisting of a number of landings along the 80th Meridian West will be made by R4D. This three-man party will examine the ice-cap between the Horlick and the Sentinel Mountains. Between eight and 12 landings will be made.

Bellingshausen Sea Expedition: There will be a two-ship expedition to the Bellingshausen Sea. It is ex-

pected that the National Science Foundation will support four to eight scientists who will participate. These scientists will conduct geological, biological and oceanographic studies and provide topographic control to various portions of the coast line and make a number of other observations, dependent on the area of the Amundsen-Bellingshausen sea-coast penetrated.

Navy Surveys

Task Force ships will conduct

hydrographic surveys throughout the operations. Sea ice will be studied and reported on and helicopters will be employed for photographic delineation of coastlines for the correction of current charts. In addition, topographic surveys will be undertaken in order to establish and verify landmark locations.

Naval Weather Service personnel will observe and record weather constantly both aboard ship and at several stations on the continent. Naval personnel are responsible for all weather programs at NAF McMurdo and Hallett Station during the entire year. At some seasons, Navy aerographer's mates are stationed at Byrd Station, NAAF Beardmore and NAAF Little Rockford to make surface and upper air observations and forecasts.

This year, an automatic weather station will be anchored between Australia and Antarctica and several land-type automatic stations, known as "grasshoppers," will be placed at various points on the continent. These stations will provide important weather information from unoccupied locations.

All in all, it will be a busy summer down Antarctic way.

WINTER WONDERLAND—Navy and Coast Guard icebreakers open up British base located on Palmer Peninsula.





TV on Ice

DOWN ANTARCTIC WAY where ships and men are constantly fighting the frigid elements, uss *Glacier* (AGB 4) has been experimenting with a new way to help her blaze a trail through ice-filled waters. She has been using a helicopter equipped with a television camera as a forward scout. As the copter flies ahead of the ship, the TV camera transmits a picture of ice conditions back to a screen aboard *Glacier*, enabling the icebreaker to pick the path of least resistance.

Top Left: Helicopter takes off from deck of *Glacier* to shoot pictures of ice conditions ahead. *Top Right:* LCDR H. R. Walker makes final adjustment on TV camera in copter's cockpit. *Right:* Copter pilot ENS T. H. Howarth, Jr., watches check-out of camera. *Lower Right:* *Glacier* makes her way through ice field. *Lower Left:* A. R. Cooks, RD1, turns on TV receiver in *Glacier* while keeping copter posted by radio.





ON LAND OR SEA when landing, one of a pilot's best friends is the ET and EN team that keeps GCA running.

GCA's Forgotten Men

ASK ANY PILOT who's ever been talked in for a landing. Aided by the magic of ground-controlled approach he has found his way through storm or fog onto a runway he can't see until the last few seconds.

He'll tell you, in no uncertain terms, that the unseen air controlman who used Air Surveillance and Precision Approach Radar to guide him home is a special kind of genius—and rightly so.

Our purpose, however, is to focus some deserved attention on another part of the GCA (Ground Control Approach) team—the electronics technicians and enginemen who repair and maintain the equipment which keeps the air controlman in business.

GCA equipment maintenance at any airfield or on board any aircraft carrier is the responsibility of an electronics maintenance officer and his crew of technicians and enginemen.

The usual GCA team is made up of three officers and about 19 sailors. Two of the officers are GCA duty officers, the third is the electronics maintenance officer. Usually, three of the enlisted men are electronics technicians, one an engineman, and the rest are controllers.

Upwards of 300 electronics tech-

nicians, more than 50 electronics maintenance officers, and some 55 enginemen are stationed at the 55 GCA units maintained at Navy air establishments throughout the world. These men are all graduates of the Navy's GCA maintenance training courses at the Naval Air Technical Training Unit, Olathe, Kans.

GCA TRAILERS make up a total of 32 of the 55 GCA units. They contain what the technicians familiarly refer to as the "AN/CPN-4" and "AN/MPN-5" radar systems, plus as many as 10 communication receivers and transmitters, and a recording device and direction finder. The entire unit, including diesel engine auxiliary power unit, air-conditioning equipment, heating system, tractor and trailer, weighs about 25 tons.

At an airfield the trailer is driven onto a fixed hardstand. Here the technician takes over, positioning, aligning and tuning the trailer, and adjusting transmitters and receivers for frequency and output.

Fifteen RATCC (Radar Air Traffic Control Centers) are installed at the Navy's major all-weather air stations. These are fixed units, ensconced in control towers, and much more complex and comprehensive than the GCA trailer type. Most RATCC in-

stallations use the AN/FPN-28 system.

The remaining eight units are of the Air Surveillance Radar (AN/GPN-6) type, normally installed only at seaplane bases. Seaplanes are capable of making blind landings, making precision radar unnecessary at these sites.

Each of these systems is so highly technical that technicians and enginemen are required to specialize in learning to repair and maintain just one of them. As a result, a student arrives at NATECHTRAU Olathe with orders to his ultimate GCA or RATCC station. The type of equipment he is trained to repair and maintain is the type which is in use at that station.

The Electronics Maintenance Training Course at Olathe is geared to instruct an input of 12 men every four weeks. Classes are intentionally kept small to permit the near-individual instruction required. Maximum emphasis is placed on practical training, with almost 80 per cent of the student's time devoted to actual work on equipment under close supervision.

ONLY THE MOST highly qualified "fleet radar experienced" electronics technicians second class and above and aviation electronics tech-

nicians second class and above are selected for the course. Most of them are graduates of previous "A," "B" and, in some cases, "C" schools, and have long since proved their qualifications in electronics. They are ordered to the program through Seavey and GCA assignment divisions of this Bureau.

Once arrived at Olathe, each man is interviewed and given a comprehensive "diagnostic" examination, covering the entire field of communications and radar electronics equipment. His background and ambitions are explored. He is informed of the career opportunities and responsibilities confronting him.

The concentrated 18-week course of electronics instruction to which they are assigned is divided into five phases. Each must be thoroughly mastered before the student progresses to the next.

During the first phase, students review typical radar and communications circuits using diagrams encountered later in the course on actual equipment. They learn what to the uninitiated is a whole new language. For example they cover

limiters, clampers, types of oscillators, multi-vibrators, modulators, time-delay and sweep circuits. They get an explanation of all of the UHF, VHF, MHF, direction finder and recorder equipment, and an operational check-out on each.

PHASE TWO covers *search radar*, including the introduction of many advanced circuits such as the "moving target indicator" and "coherent oscillators." About 160 hours are equally divided between lab and classroom. Again, students work in the lab on equipment identical to that which they'll use later in a GCA or RATCC set-up.

Precision radar is covered in phase three. Since final aircraft approach to a GCA site is made on precision radar, the equipment encountered in this portion of the course demands and gets even more critical attention. More than two-thirds of the training time in this phase is spent in the lab and in complete GCA trailers.

During phase four, the students learn to service search and precision antennas and indicators. Angle volt-

age generators, servo-systems, sweep circuits and deflection systems are covered in this unit of the course.

The final, or field, phase is an application of the entire GCA maintenance course. The major part of the students' time is spent in an operating GCA trailer, which has been positioned, aligned and tuned by the students themselves. They adjust transmitters and receivers, learn to keep maintenance logs, failure reports, records of equipment usage, and a spare parts inventory. They also become familiar with the supply organization peculiar to GCA.

DURING THIS FOUR-WEEK period in the field, the student "lives" GCA maintenance and alignment from bow to stern. He develops a feeling of confidence in himself and his equipment. He often has the opportunity of seeing aircraft actually making runs on equipment he has completely serviced and readied.

Students headed for a duty station using Air Surveillance Radar remain at the school for an additional four-week block of instruction after completion of the basic 18-week course.

BIG JOB—There are many parts to keep humming and stock to keep rolling in Ground Control Approach units.

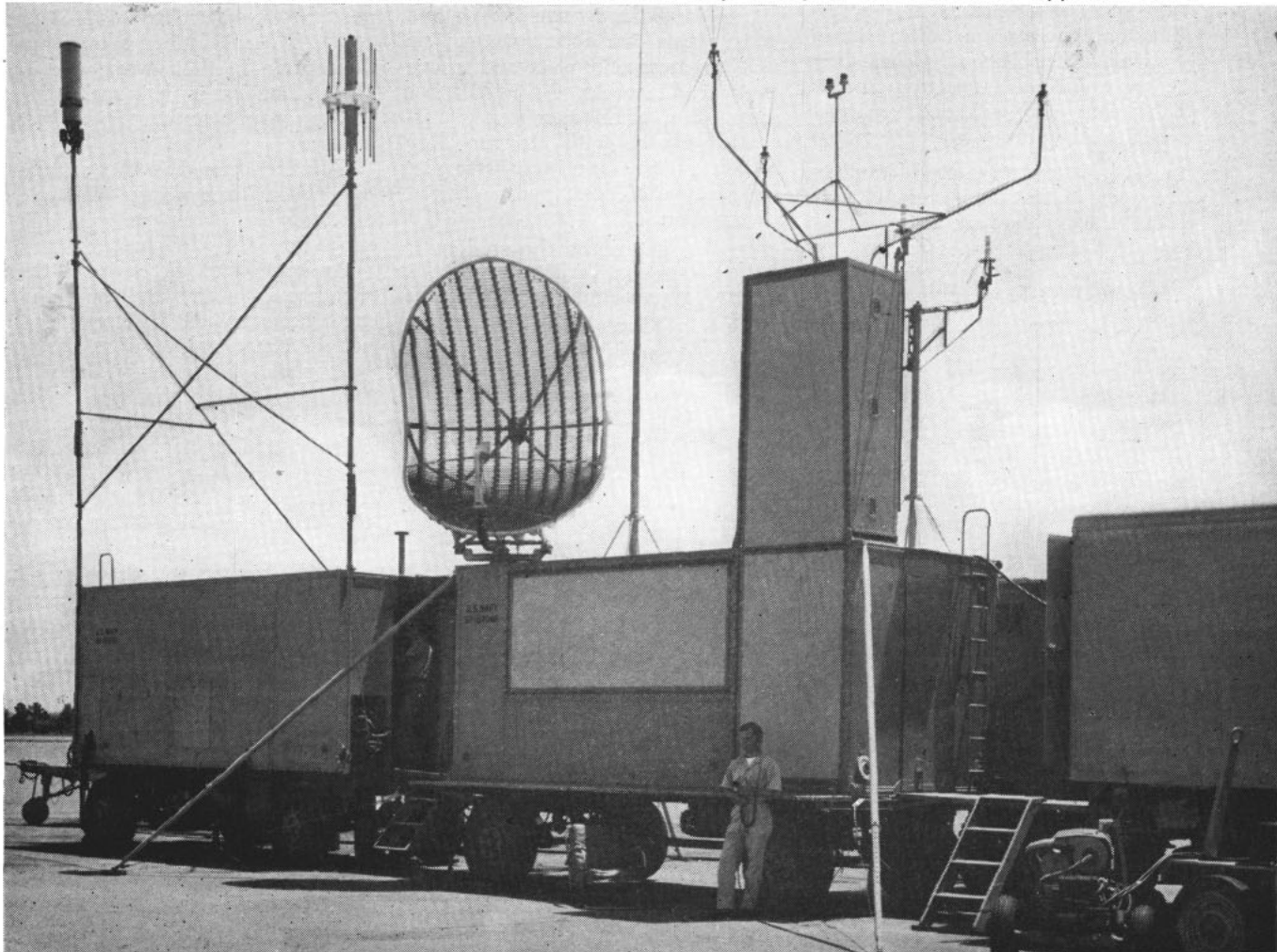



SKILLED HANDS are specially trained to maintain GCA equipment. This includes rolling stock, auxiliary diesel engines, a variety of electrical gear.

They are given added instruction in maintenance techniques for inter-communications, various systems used, and tower communication equipment.

A close personal relationship exists between instructors and technician students at Olathe. Graduates of the GCA maintenance course are urged to think of NATECHTRAU as their "alma mater" and to keep in close touch for the exchange of information and suggestions regarding further improvement in maintenance training. The school constantly strives to include instruction on new equipment and advanced maintenance techniques.

WHILE THE INCLUSION of engineers in the GCA program may seem strange, they are an important part of the maintenance team.

TEAM WORK—Team usually consisting of three officers and 19 sailors keeps GCA operating. Here, GCA team takes time to celebrate approach 60,000.

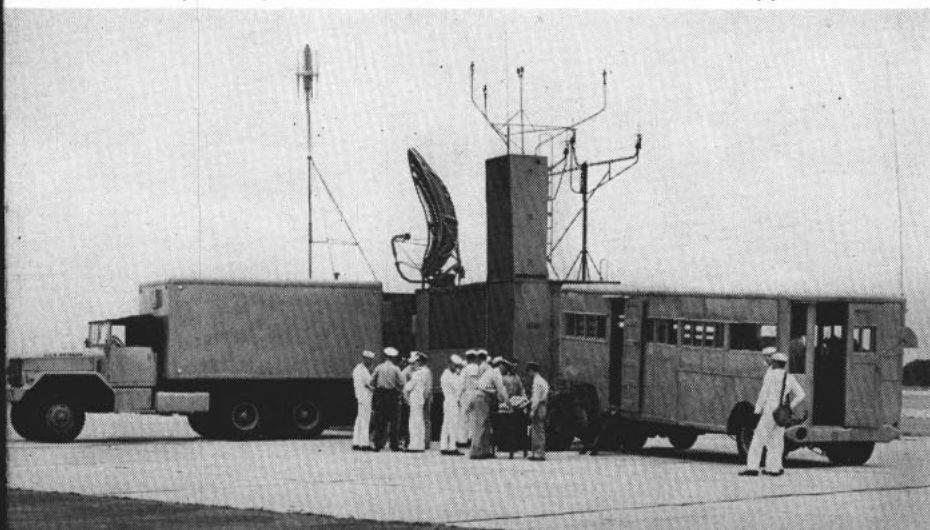

Diesel engine auxiliary power units, and air-conditioning equipment and heating systems associated with a GCA unit all require considerable upkeep and repair. The prime mover and rolling stock are also the responsibility of the maintenance crew. The Class "C" type of instruction which provides the skills demanded by this equipment is contained in the GCA Engineman Training Course at Olathe.

The course is 10 weeks long and is available to approximately six enginemen second class and above every eight weeks. As with other technicians, engineman trainees arrive at Olathe with ultimate duty station orders, and are instructed on the type of equipment in use at that station.

In the first phase the student is

introduced to the new—to him—field of electrical machinery. He learns the repair and upkeep of motors, generators, starter circuits and all common electrical test equipment.

Phase two covers the checking, testing, trouble-shooting and maintenance of the main power equipment and its driver, fuel supply, cooling system, control panels and the seven-ton electrically driven air-conditioning plant.

Engineman maintenance trainees spend more than 80 hours putting all this instruction into actual practice in the field or operational portion of the course. Over and over again they practice starting, securing and daily check of all equipment, the keeping of logs, and proper positioning and driving procedures for the 25-ton GCA trailer. Each student is examined for a standard Navy driver's license.

Officers slated to become electronics maintenance officers get the same 18-week course as the blue-jackets. The final four weeks is devoted to study of administrative procedures such as procurement of spare parts and equipment, training, and keeping of logs and records.

TECHNICIANS attached to GCA and RATCC installations take tremendous pride in their work, and are almost fanatical in their zeal to keep the equipment working at peak efficiency.

This is reflected in the complete confidence felt by Navy pilots, who are ready and willing to trust themselves to GCA guidance.

An example of just how well these men know their job and their equipment occurred not so long ago at a certain Navy airfield.

A plane had already begun its final approach to the landing strip when the GCA equipment commenced malfunctioning because of a blown tube.

In the space of a few seconds the technician was able to (1) diagnose the trouble, (2) locate the burned-out tube among the thousands involved, and (3), substitute a new tube from his ever-ready spare box (his coat pocket).

This bit of trouble-shooting under pressure was accomplished so fast the plane was able to continue its landing uninterrupted, rather than take a wave-off and make another approach.

—Jerry McConnell, JO1, USN



INSIDE JOB—H. F. Carey, TDAN, and J. J. Sailor, TD3, (Rt) man controls of F3D Flight Trainer and Space Simulator.

FLYING TRAILERS

TRADEVMEN at NAAS Chase Field are kept busy with two new trailer-van "flying machines," which contain training equipment that simulates fighter interceptor flying conditions for student pilots.

One of these trailers houses a weapons system trainer that has the type of fire control radar used by the Navy's all-weather fighters for air intercepts. Inside, the van is divided into three different sections. Up forward is the cockpit, the same as in an actual plane, with stations for both pilot and radar operator. The pilot flies his 'aircraft' under instrument conditions. The radar operator has a radar scope and controls.

Amidships in the trailer is the maze of wiring and gear used to set up the intercept problems for the pilot while the aft section contains the electronic computer that reacts to the movements of the pilot's controls and gives him instrument indications of flight.

The second trailer contains the 15V5 space simulator. This unit computes altitude, relative bearing and range between fighter and bogey. From this information it generates a target that is fed onto the radar scope in the cockpit of the first trailer.

This training device enables student pilots to become proficient at

radar interception without the cost and the danger of actually flying.

The white hats behind these devices wear the Trademan's insignia. As a very important part of aviation training these Navymen are schooled in how to operate and maintain many complicated training aids.

TDs also run training aids for other branches of the Navy.

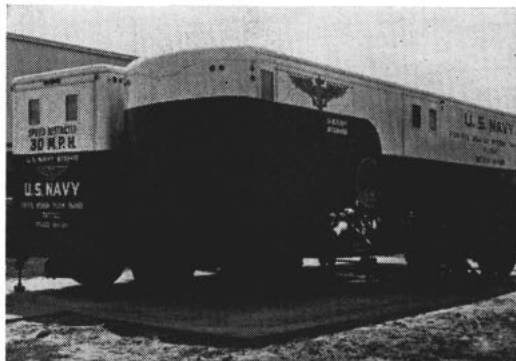

FLYING HIGH—Student pilot takes over controls for simulated intercept flight in new trainer. Above: The training unit is housed in two vans.





NO ACCIDENT—CAPT C. E. Gibson, CO of *Thetis Bay*, congratulates LT R. L. Norton after 15,000th accident-free landing. Below: New copter is tested.



HEAVY HAUL—Copter airlifts jeep.

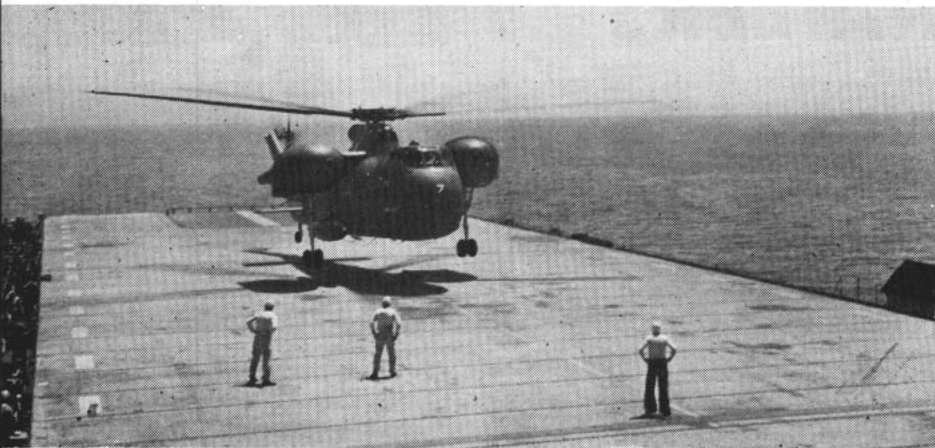

ARMY'S AT SEA—Soldiers board copter during operations off *Thetis Bay*.



Amphib

FIFTEEN THOUSAND accident-free landings is quite a record in any league—but when it's accomplished by helicopters aboard an amphibious assault ship it becomes an outstanding example of aerial artistry.

That many successful landings have been made aboard *uss Thetis Bay* (LPH 6). First Lieutenant R. L. Norton, USMC, flying an HUS with Marine Helicopter Transport Squadron 362, made the 15,000th landing recently during individual ship exercises off the coast of Okinawa.

Assault helicopter operations aboard LPHs demand the utmost in skill and precision. *Thetis Bay's* no-accident record has been racked up under all sorts of wind and deck conditions, day and night, during numerous amphibious exercises with units of the Pacific Fleet over the past three years.

The over-all helicopter casualty rate is three times that of fixed wing aircraft.

Thetis Bay, ex-CVE 90, was the first converted for the purpose of operating exclusively with helicopters. Her successful pioneering in the use of vertical envelopment tactics in cooperation with the Marine

ALL HANDS



HELICOPTER demonstrates rescue during operations with USS *Thetis Bay* (LPH 6). Below: Crew celebrates safety record.

Landings by Air

Corps has led the Navy to utilize two former CVs, USS *Boxer* (LPH 4), ex-CVS 21, and *Princeton* (LPH 5), ex-CVS 37, as LPHs.

During her conversion in San Francisco Naval Shipyard, *Thetis Bay* had about 20 feet lopped off each end of her flight deck. Catapults, arresting gear and two centerline elevators were removed. The forward section of the hangar deck was converted into troop quarters, engine shops and spare parts stowage rooms.

An 18-ton aluminum aircraft elevator was installed, and the hangar deck reinforced. Piping and ventilation systems were redesigned, and more than two and a half miles of new ventilation ducting was installed.

Marine ammunition and equipment, stowed below decks, necessitated design of a new type of cargo elevator. It was built in two stages—the lower stage running from the first platform to the hangar deck, the upper stage traveling between the hangar deck and the flight deck on the port side of the ship.

Catwalks were widened so that combat-equipped troops could get from their compartments to helicop-

ter embarkation points faster and easier. New maintenance facilities include a 12-ton hoist which can lift an entire copter, and a monorail hoist running athwartships the width of the hangar.

During a typical exercise, an entire Marine Helicopter Transport Squadron embarks in *Thetis Bay*. They fly HUS copters which can carry up to 12 troops. An external load could be a jeep, "mule" or nearly a ton of rations, ammunition, water, gas or other cargo carried in slings or baskets.

Upwards of 1000 fully equipped Marines, forming a Battalion Landing Team, go aboard for an operation.

D-Day begins with 0400 reveille for the entire ship. Flight quarters are sounded at 0430, and the first launch is made in early morning twilight. The helicopters are launched in groups of four. After rendezvousing they roar in to land at a pre-designated spot, in one wave putting more than 140 combat-ready Marines on the beach. Returning to the ship, the copters land in formation in groups of four, load and take off again. The time involved in landing, gassing, reloading and takeoff is ap-

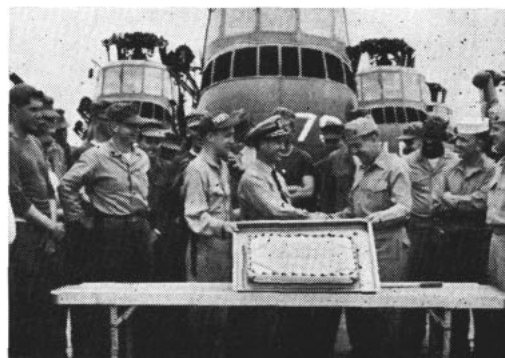

proximately the same as is required to read this article.

Because of *Thetis Bay's* short flight deck, two spots are used for external pickups. The cargo or vehicle is spotted, the helicopter hovers over it, and two men run underneath to make the hookup. This whole maneuver must be perfectly coordinated between pilot, signalman and hookup crew.

While launching and recovering, helicopters can be spotted either with the main rotor spread or folded. A crew can spread the four main blades and the tail pylon of an HUS and fold them again in less time than it takes to fuel the aircraft. With 16 or more HUSs operating at once, it becomes necessary to perform this spreading and folding many times over. But it pays off.

"...above and beyond

FOR CONSPICUOUS GALLANTRY and intrepidity at the risk of his life above and beyond the call of duty. . . . He gallantly gave his life for his country . . ." the President said as he presented the Medal of Honor.

A proud moment—for this is the highest decoration that can be awarded in the nation. But it is won dearly. More often than not the Medal of Honor is presented to a member of the family rather than to the hero himself.

Deeds for which the Medal of Honor have been awarded are varied. A captain has gone down with his ship rather than surrender; another captain ordered his submarine to submerge while he lay wounded on deck; a first class petty officer dropped into a burning magazine to extinguish the flames and save his ship; and a mortally wounded seaman died struggling to steer his LST out of the path of an oncoming torpedo.

But not all Medals of Honor are awarded posthumously. A lone fighter pilot destroyed five of nine enemy bombers as they attacked his ship; a Navy lieutenant led a boarding party aboard a World War II German submarine that might have exploded at any moment; and a submarine captain took his ship within six miles of the Japanese fleet and sank five enemy destroyers in as many short-range torpedo attacks. Each survived.

FIFTY-FIVE U. S. Navy ships now in commission are named for Medal of Honor winners.

To add to a man's pride as a crew member of one of these ships, and to serve as a tribute to the traditions for which his ship stands, the Decorations and Medals Branch of the Bureau of Naval Personnel is sending to each of these ships a copy of the citation presented to the man for whom the ship is named.

The citation is embossed with a color print of the Medal of Honor. Accompanying this is a biography of the man who won the Medal. The citations are to be framed and displayed along with the biography of the Medal of Honor winner and a ship's history. (The citation and biography should reach all the ships before the end of this year.)

The first of these citations was sent to the submarine tender *uss Howard W. Gilmore* (AS 16). The story of CDR Gilmore is well known. But for those who are not familiar with it, or for those who may have forgotten the details, here's what happened:

Gilmore was commanding officer of the submarine *uss Growler* (SS 215) which was on her fourth war patrol in the Southwest Pacific in early 1943. It had been a successful patrol.

In spite of hostile air and anti-submarine attacks, *Growler* had sunk one Japanese freighter and damaged another by torpedo fire. Severe depth-charge attacks had been evaded after each action.

During the night of 7 Feb 1943, however, *Growler* was surfaced. Suddenly, from out of the darkness, an enemy gunboat bore down on

her. CDR Gilmore, in a surprise move, maneuvered *Growler* to avoid being rammed and instead rammed the gunboat. At 17 knots, *Growler* opened a hole in the gunboat's hull.

As the enemy ship faltered, her crew members fired their machine guns in an effort to inflict further damage on the submarine and its crew. CDR Gilmore gave the order to clear the deck, allowing his men to precede him below.

Badly wounded, alone on deck, and unable to reach the ladder unaided, CDR Gilmore gave his last order—"Take her down." His well-trained crew submerged the damaged submarine and returned to port.

THE MEDAL OF HONOR went to Watertender First Class Elmer Charles Bigelow—*uss Bigelow* (DD 942) is named for him—for extraordinary heroism in putting out a magazine fire aboard *uss Fletcher* (DD 445).

The action started when an enemy shell exploded aboard, penetrated the number one magazine and set afire several powder cases. Bigelow grabbed two fire extinguishers and went below to quell the raging fire. With no time to get rescue breathing apparatus, he dropped into the burning magazine. Despite the acrid burning powder smoke which seared his lungs with every breath, he extinguished the fire. The following day, Bigelow died as a result of his injuries.

LT Edward Henry O'Hare—*uss O'Hare* (DDR 889) is named for him—won his Medal of Honor in the early days of WW II. On 20 Feb 1942, LT O'Hare single-handedly attacked nine enemy, twin-engine heavy bombers which were headed for his ship. Despite heavy machine-gun and cannon fire from the bombers, he shot down five of the planes and damaged a sixth before they reached the bomb release point.

Another naval aviator won the Medal of Honor in one of the most daring bombing runs of the war. LCDR Bruce Avery Van Voorhis, on 6 Jul 1943, took off in his PB4Y-1 patrol bomber, unescorted and in total darkness, on a 700-mile voluntary flight to Greenwich Island in the Solomon Islands.

Present Medal of Honor

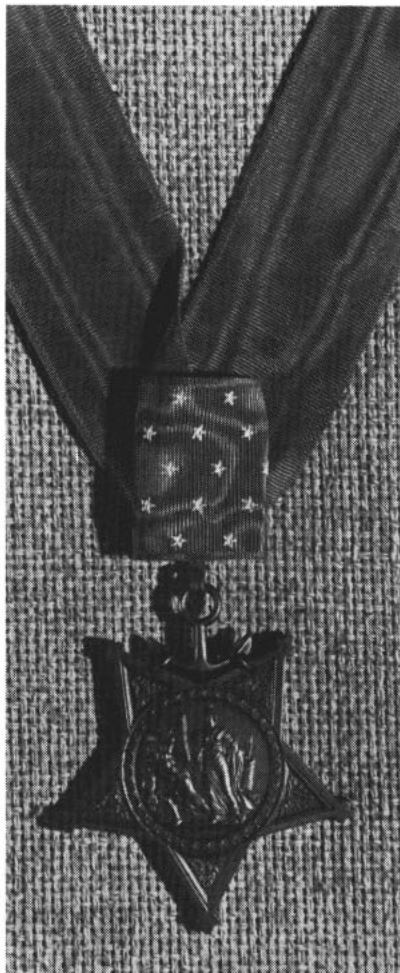

the call"

Despite treacherous and varying winds, low visibility and difficult terrain, he fought a lone, but relentless battle to reach his target. He was continually under heavy attack from both the air and the ground.

He made six ground-level attacks to demolish the enemy's radio station, installations and anti-aircraft guns and crews. He also destroyed one fighter plane in the air and three more in the water.

Even then, enemy fire didn't shoot down Van Voorhis' plane. He was finally caught in his own bomb blast and crashed in the lagoon off the beach.

ON IWO JIMA a Navy pharmacist's mate first class, John Harlan Willis—uss *John Willis* (DE 1027) is named for him—was performing his corpsman duties with the Third Battalion, 27th Marines, Fifth Marine Division. Under heavy enemy artillery and mortar fire, Willis treated many Marines until he was himself wounded and ordered back to a first aid station for treatment.

Later, without waiting for an official medical release, Willis returned to his front-line platoon and continued his life-saving work. During a hand-to-hand enemy counterattack, Willis advanced to the extreme front



BATTLE SCENE—Many brave deeds were performed by Navymen in WW II. One hundred thirty eight Medals of Honor were awarded Navymen, Marines.

lines under heavy mortar and sniper fire to aid a Marine lying wounded in a shell hole.

He administered blood plasma to the wounded man even as he was bombarded by enemy hand grenades. He returned the first one as he continued to administer the life-saving fluid. The enemy poured grenade after grenade at him. He kept throw-

ing each back in quick succession until the ninth one exploded in his hand and killed him.

TOWARD THE END of World War II, in January 1945, CDR George Fleming Davis—uss *Davis* (DD 937) is named for him—won his Medal of Honor while commanding officer of uss *Walker* (DD 723).

PRESIDENTS Eisenhower and Truman present MOH to W. R. Charette, HM3, and G. E. Wahlen, PHM1c, USN.





NAMESAKE—USS *John Willis* (DE 1027) was named after Medal of Honor winner John Harlan Willis, PmM2c, right.

His ship was engaged in support of minesweeping operations to clear the waters for heavy-surface and amphibious forces at Lingayen Gulf, Luzon, Philippine Islands. While operating without gun support from other surface ships, *Walker* was attacked simultaneously by four Japanese suicide planes.

CDR Davis took his position in the exposed wings of the bridge and directed the action from there. He ordered control to pick up the lead plane and open fire. The first plane plunged into the sea. The second one passed close over the bridge as it, too, nosed into the ocean.

CDR Davis remained at his post as the third plane crashed the after end of the bridge. Seriously wounded, drenched in gasoline, and with the bridge enveloped in flame, CDR Davis remained on his feet to see the last plane destroyed.

THE BEGINNING—First Medals of Honor were presented for deeds performed during Civil War in action such as this during the battle of New Orleans.

Even then, he assured himself that the fires were under control and the ship was safe before he agreed to be carried below. Several hours later, he died.

ON 18 JUN 1945, Fred Faulkner Lester, Hospital Apprentice First Class, USN, while serving with the Marine Corps on Okinawa Shima, earned a Medal of Honor for this deed of heroism:

He was on the front lines as the Marines were attacking a Japanese hill position in the Ryukyu chain. Following an assault on this position, Lester saw a wounded Marine lying in an open field. Despite heavy gunfire that struck him once as he inched forward toward the Marine, he dragged the wounded man toward safety. As he was returning to his position, he was shot a second time. He was too badly wounded

to administer first aid. He realized his own wounds were fatal, and refused medical aid for himself. Instead, he directed others in their treatment of not only that wounded man, but also many others before he died. *uss Lester* (DE 1022) is named for him.

HERE IS A LIST of all the U. S. Navy ships that are now in commission and currently under construction that are named for Medal of Honor winners:

uss Howard W. Gilmore (AS 16), named for CDR Howard W. Gilmore, USN; **uss Daly** (DD 519), named for Sergeant Major Daniel Daly, USMC; **uss Miller** (DD 535), named for Acting Master's Mate James Miller, USN; **uss Stoddard** (DD 566), named for Acting Master's Mate James Stoddard, USN; **uss Bearss** (DD 654), named for Brigadier General Hiram I. Bearss, USMC; **uss Kidd** (DD 661), named for Rear Admiral Isaac Campbell Kidd, USN.

uss Hugh Purvis (DD 709), named for Corporal Hugh Purvis, USMC; **uss Laffey** (DD 724), named for Acting Master's Mate Bartlett Laffey, USN; **uss Buck** (DD 761), named for Master's Mate James Buck USN; **uss Gurke** (DD 783), named for Private First Class Henry Gurke, USMC; **uss Richard B. Anderson** (DD 786), named for Private First Class Richard B. Anderson, USMC; **uss Cassin Young** (DD 793), named for Captain Cassin Young, USN.

uss Rooks (DD 804), named for Captain Albert Harold Rooks, USN; **uss Robert H. McCard** (DD 822), named for Gunnery Sergeant Robert Howard McCard, USMC; **uss Ager-**

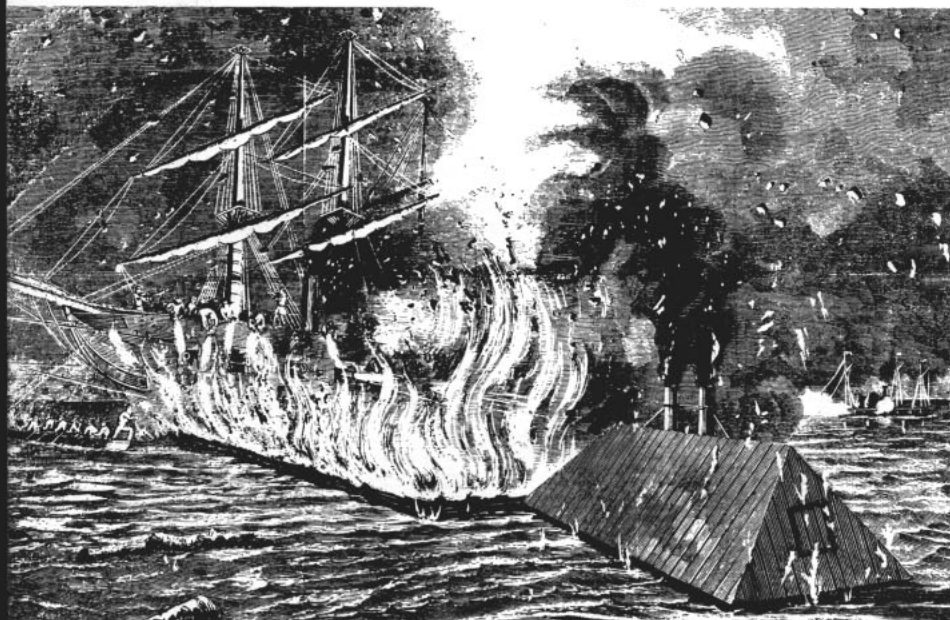

holm (DD 826), named for Private First Class Harold Christ Agerholm, USMCR; *uss Power* (DD 839), named for First Lieutenant John Vincent Power, USMCR; *uss Ozbourn* (DD 846), named for Private Joseph William Ozbourn, USMCR; *uss Witek* (DD 848), named for Private First Class Frank Peter Witek, USMCR.

uss Richard Kraus (DD 549), named for Private First Class Richard Edward Kraus, USMCR; *uss Leonard F. Mason* (DD 852), named for Private First Class Leonard Foster Mason, USMC; *uss Charles H. Roan* (DD 853), named for Private First Class Charles Howard Roan, USMC; *uss Davis* (DD 937), named for Commander George Fleming Davis, USN; *uss Jonas Ingram* (DD 938), named for Admiral Jonas Howard Ingram, USN; *uss Bigelow* (DD 942), named for Elmer Charles Bigelow, Watertender First Class, USN.

uss Edson (DD 946), named for Major General Merritt Austin Edson, USMC; *uss Fletcher* (DDE 445), named for Rear Admiral Frank Friday Fletcher, USN; *uss Epperson* (DDE 719), named for Private First Class Harold Glen Epperson, USMCR; *uss New* (DDE 818), named for Private First Class John Dury New, USMC; *uss Basilone* (DDE 824), named for Sergeant John Basilone, USMC.

uss Robert A. Owens (DDE 827), named for Sergeant Robert A. Owens, USMC; *uss Robert L. Wilson* (DDE 847), named for Private First Class Robert Lee Wilson, USMC; *uss Damato* (DDE 871), named for Corporal Peter Anthony Damato, USMC; *uss Kenneth D. Bailey* (DDR 713), named for Major Kenneth D. Bailey, USMC; *uss William R. Rush* (DDR 714), named for Captain William Rush, USN.

uss Corry (DDR 817), named for Lieutenant Commander William Merrill Corry, Jr., USN; *uss Hanson* (DDR 832), named for First Lieutenant Robert Murray Hanson, USMC; *uss Herbert J. Thomas* (DDR 833), named for Sergeant Herbert J. Thomas, USMCR; *uss Hawkins* (DDR 873), named for First Lieutenant William Dean Hawkins, USMCR; *uss Dyess* (DDR 880), named for Lieutenant Colonel Aquilla James Dyess, USMCR; *uss Bordelon* (DDR 881), named for Staff Sergeant William James Bordelon, USMC.

uss O'Hare (DDR 889), named



World War I Medal of Honor

for Lieutenant Edward Henry O'Hare, USN; *uss Huse* (DE 145), named for Vice Admiral Henry McClaren Pinchney Huse, USN; *uss Peterson* (DE 152), named for Chief Watertender Oscar Vernon Peterson, USN; *uss Douglas A. Munro* (DE 442), named for Douglas A. Munro, Signalman First Class, USCG; *uss Parle* (DE 708), named for En-

sign John Joseph Parle, USNR; *uss Dealey* (DE 1006), named for Commander Samuel David Dealey, USN; *uss Courtney* (DE 1021), named for Major Henry Alexius Courtney, Jr., USMCR; *uss Lester* (DE 1022), named for Fred Faulkner Lester, Hospital Corpsman First Class, USN.

uss Evans (DE 1026), named for Commander Ernest Edwin Evans, USN; *uss John Willis* (DE 1027), named for John Harlan Willis, Pharmacist's Mate First Class USN; *uss Van Voorhis* (DE 1028), named for Lieutenant Commander Bruce Avery Van Voorhis, USN; *uss Claud Jones* (DE 1033), named for Commander Claud Ashton Jones, USN; *uss Wilkinson* (DL 5), named for Vice Admiral Theodore S. Wilkinson USN; *uss Bausell* (DD 845), named for Corporal Lewis Kenneth Bausell, USMCR; and *uss Bauer* (DE 1025), named in honor of Lieutenant Colonel Harold William Bauer, USMC; *uss Keppler* (DDE 765) named for Reinhardt J. Keppler, BM2c, USN; *uss Cromwell* (DE 1014) named for CAPT John P. Cromwell, USN; *uss Hammerberg* (DE 1015) named for Owen F. P. Hammerberg, BM2c, USN; *Charles Berry* (DE 1035) named for CPL Charles J. Berry, USMC; *John King* (DDG 3) named for John King, WT, USN.

THE NAVY MEDAL OF HONOR—the U. S. Army also has a Medal of Honor—is often referred to as the Congressional Medal of Honor. It has been awarded to 966 Navy and Marine Corps men and to one member of the Coast Guard. Of these, 138 medals were conferred during WW II (77 posthumously); during

LAST ACTION in which Navymen earned the Medal of Honor was during the Korean conflict. A total of 49 top decorations were given Navymen, Marines.



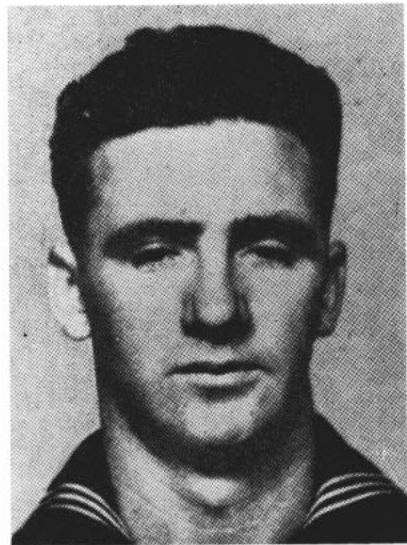

CARRYING ON—USS *Hammerberg* (DE 1015) carries name of heroic Navy diver Owen F. P. Hammerberg, BM2, USN.

the Korean conflict, 49 men received the high award (33 posthumously).

The most recent Navy Medal of Honor went to LTJG John Kelvin Koelsch, USN, for his attempt to rescue a Marine aviator who had been shot down in North Korea on 3 Jul 1951.

The Medal of Honor was first authorized on 21 Dec 1861 for enlisted men only, as an act, to promote further "the efficiency of the Navy." The star-shaped medal of bronze shows the figure of Minerva (the Union), encircled by the stars of the 34 states of 1861. Minerva holds in her left hand the fasces (badge of authority). The shield in her right hand is driving off the serpents held by the crouching figure of Discord.

Although the World War I Medal was changed in appearance, the present design and that of the Civil War period are identical. Only the clasps are different. Today there are many medals, appropriate for all types of service as well as for heroism. Until 1919, when the Distinguished Service Medal and Navy Cross were authorized, the Navy had only the Medal of Honor to award. In 1926 the Distinguished Flying Cross was authorized, all these new medals to be retroactive to 6 Apr 1917.

OFFICERS WERE FIRST AWARDED the Medal of Honor for action on 21 and 22 Apr 1914 during the Mexican Campaign. Forty-six Navy-men and nine Marines received the Medal of Honor for heroism during these two days. During WW II, 57

Navy-men, 80 Marines and one member of the Coast Guard were given the Navy's highest award. In contrast, 310 Navy enlisted men and 17 enlisted Marines received the Medal for Civil War service.

In the early days, the Medal of Honor was earned for various deeds of valor. Since it was the only decoration for bravery, some of the acts might not have qualified for a Medal of Honor today.

Here are some of the first citations:

- Edward Ringold, Coxswain, USN—"Served as coxswain on board the u.s.s. *Wabash* in the engagement at Pocatigo, 22 Oct 1862. Soliciting permission to accompany the howitzer corps, and performing his duty with such gallantry and presence of mind as to attract the attention of all around him, Ringold, knowing there was a scarcity of ammunition, went through the whole line of fire with his shirt slung over his shoulder filled with fixed ammunition which he had brought from two miles to the rear of the lines."

- William A. Stanley, Shell Man, USN—"Shell man on No. 8 on board the u.s.s. *Hartford* during successful actions against Fort Morgan, rebel gunboats and the ram *Tennessee* in Mobile Bay, on 5 Aug 1864. Although severely wounded when his ship sustained numerous hits under the enemy's terrific shell-fire, Stanley continued to pass shell until forced by loss of blood to go below."

- William Talbott, Captain of Forecastle, USN—"Served as captain

of the forecastle on board the u.s.s. *Louisville* at the capture of the Arkansas post, 10 and 11 Jan 1863. Carrying out his duties as captain of a 9-inch gun, Talbott was conspicuous for ability and bravery throughout this engagement with the enemy."

- Matthew Arthur, Signal Quartermaster, USN—"Served on board USS *Carondelet* at the reduction of Forts Henry and Donelson, 6 and 14 Feb 1862. Carrying out his duties as signal quartermaster and captain of the rifled bow gun, Arthur was conspicuous for valor and devotion, serving most faithfully, effectively and valiantly."

In nearly 100 years of existence, however, only nine men have earned the Navy Medal of Honor twice. No man has won two since 1915.

A Medal of Honor may be awarded for either combat or non-combat. The Medal is available to "Any person who, while in the naval service of the United States, shall, in action involving actual combat with the enemy, or in the line of his profession, distinguish himself conspicuously by gallantry and intrepidity at the risk of his life above and beyond the call of duty and without detriment to the mission."

That's all there is to it, that is, except that he must be recommended within three years from the date of the distinguished act or service, and be awarded the Medal within five years of such act or service.

Heroism is not out of date—it never will be.

—Erwin A. Sharp, JO1, USN.

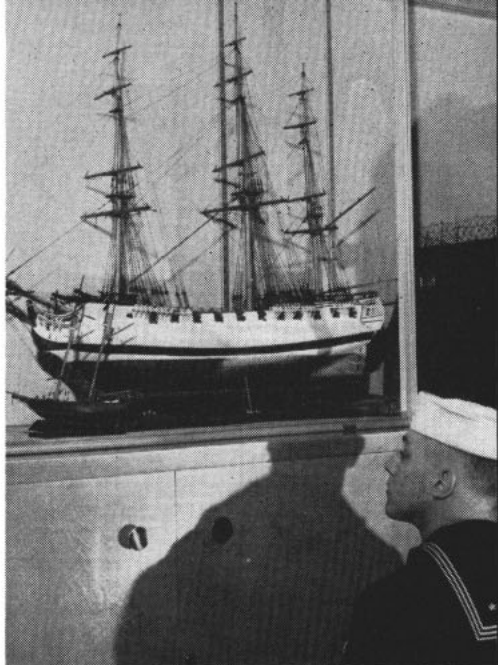
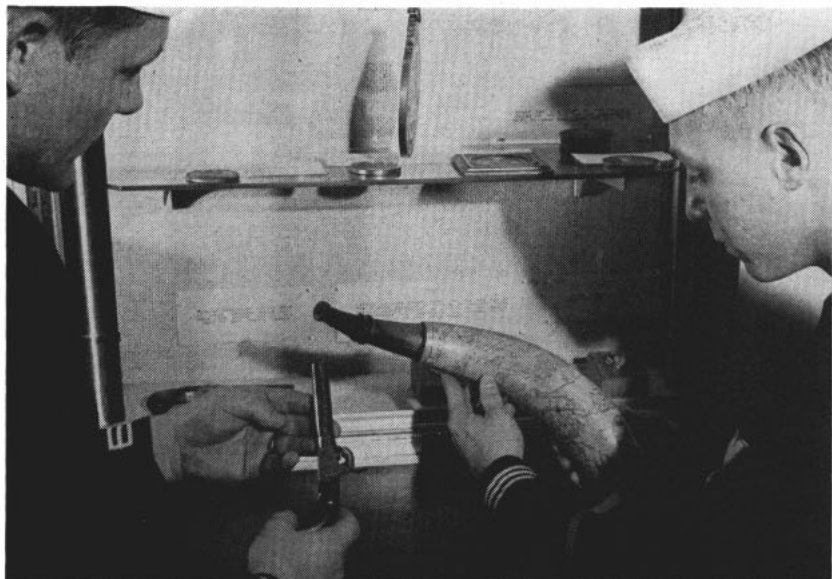

Sailor's Museum

A SPOT OF INTEREST to Navymen on leave or liberty in the area of our nation's capital is the Truxtun-Decatur Museum. Here are displayed relics of naval history that make famous ships of the past seem to come alive again.

In May of 1950 the museum was opened to display historical exhibitions devoted to seapower in all its components (Navy, Marine Corps, Coast Guard and Merchant Marine). This interesting collection of items from yesterday's Navy, gathered by the Naval Historical Foundation, is located at 1610 H Street, N.W. in downtown Washington just a short cruise from the White House. The museum is next door to the historic Decatur House, now open as a national naval shrine.

So the next time you find yourself

on leave in the nation's capital set your course toward the naval displays at Truxtun-Decatur Museum.

Top: Hand-carved powder horn used in siege of Quebec in 1767 is examined by S. D. Hutnik, Jr., YN2, USN, while L. A. Thorstenson, YN1, USN, looks at percussion pistol of 1830—1850 period. *Top Right:* Models of U. S. frigate *Raleigh* and schooner *Flying Fish* attract attention. *Right:* John McGuire, LT, USN, retired, shows Navymen a Persian astrolabe (forerunner of sextant) such as Columbus used. *Lower Right:* Museum visitor aims pistol of Commander Isaac Hull. *Lower Center:* This is not a beer mug but a copper lantern from USS *Constitution*. *Lower Left:* Cut-away working model of deck battery of French ship of the line is checked out.

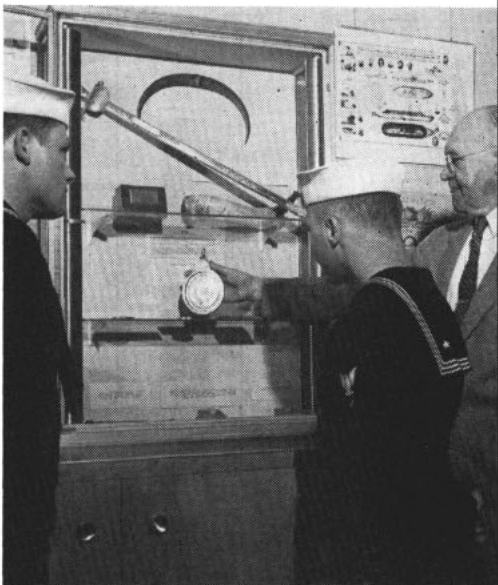

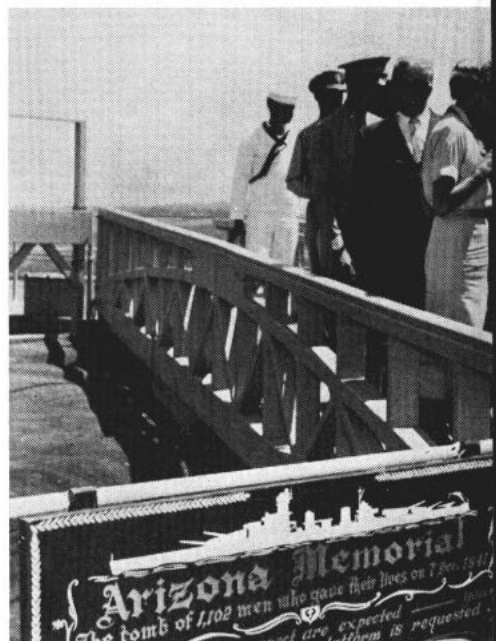

THEY COME to honor Arizona crew.

18 Years Later —

Visitors Pay

WHEN A PERMANENT memorial is erected over the sunken battleship USS Arizona (BB 14) at Pearl Harbor, no one will be prouder to see it than the 15 Navymen who staff the boathouse of the U. S. Pacific Fleet Commander, Admiral Herbert G. Hopwood, USN.

This is so because their daily lives are closely associated with the ship which was sunk by the Japanese on 7 Dec 1941. Almost every day of the year these men conduct guided tours of historic Pearl Harbor and USS Arizona for military and civilian officials. Last year they provided harbor tours for more than 12,000 visitors to the naval base.

In addition to VIPs from the United States their passenger lists have included foreign dignitaries and movie stars and on many occasions friends and relatives of the 1102 Navymen who are still entombed in the ship's rusting hulk.

In charge of the boathouse is Chief Boatswain's Mate Wyatt C. Coley, a veteran of 15 years' naval service. He has given the unit and its men the shipshape appearance that has earned them the reputation of being one of the sharpest organizations in the Pacific Fleet.

Chief Coley has four boats under

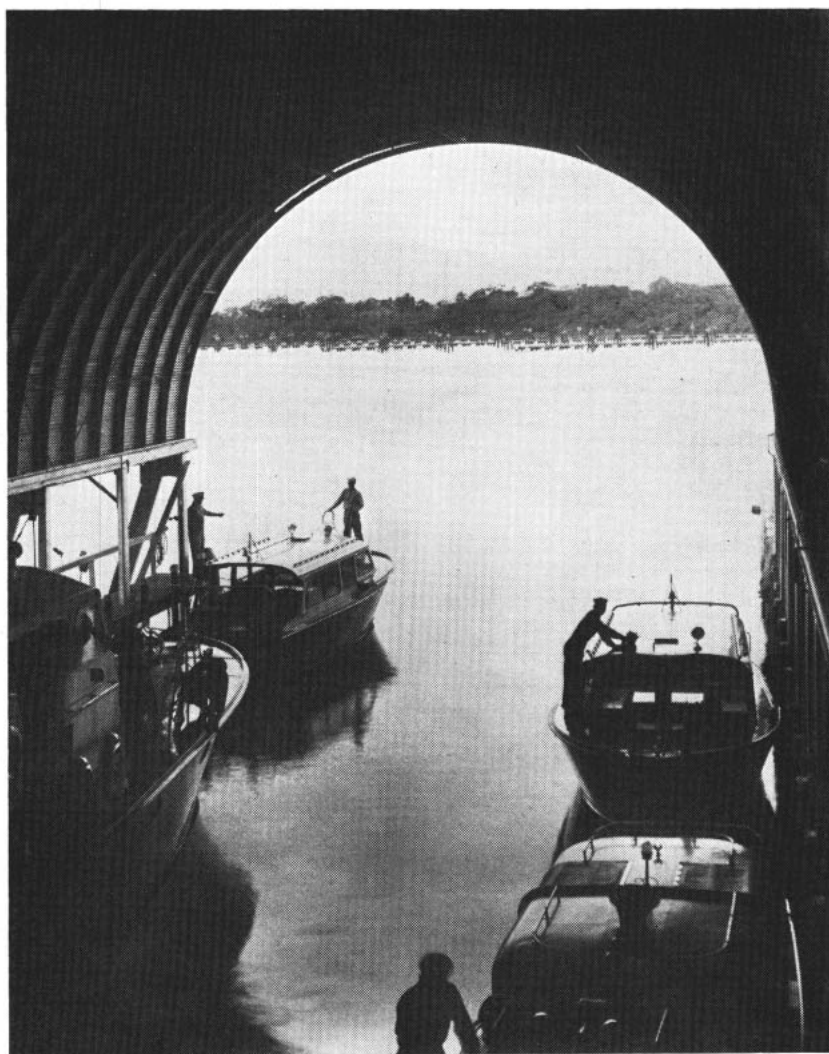

CINCPACFLT boat carries passengers to Arizona memorial (top). Above: Navy crews handle craft in boat house on Aiea side of Pearl Harbor.



INDIA'S Vice President leaves memorial. Right: The Battleship *Arizona* of earlier years is pictured here at sea.

Tribute to Crew of *USS Arizona*

his command and a crew of 14 men who operate and maintain them for both harbor tours and duty runs. In addition to being experts in small boat handling these sharp sailors must know harbor navigation and be well acquainted with the history of Pearl Harbor for they are often called on to give lectures while at the same time acting as either coxswains or bowhooks.

In 1949 the Pacific War Memorial Commission was created by the Hawaiian legislature in an effort to bind together several historic sites in that area into a Pacific Memorial. The battleship *Arizona* was chosen to represent the Pearl Harbor terminus of this system.

Plans for providing a permanent memorial structure for *Arizona* and her crew went ahead when Public

Law 85-344 was signed by the President in 1958.

This law authorizes the Secretary of the Navy to accept contributions (they should be addressed directly to *uss Arizona* Memorial, Pearl Harbor, Hawaii). The law also authorized the Navy to undertake construction of the memorial and to be responsible for the maintenance of the memorial when it is completed.

FROM ON HIGH—Photo shows tour boat approaching sunken hulk of *USS Arizona* bridged by wooden platform.

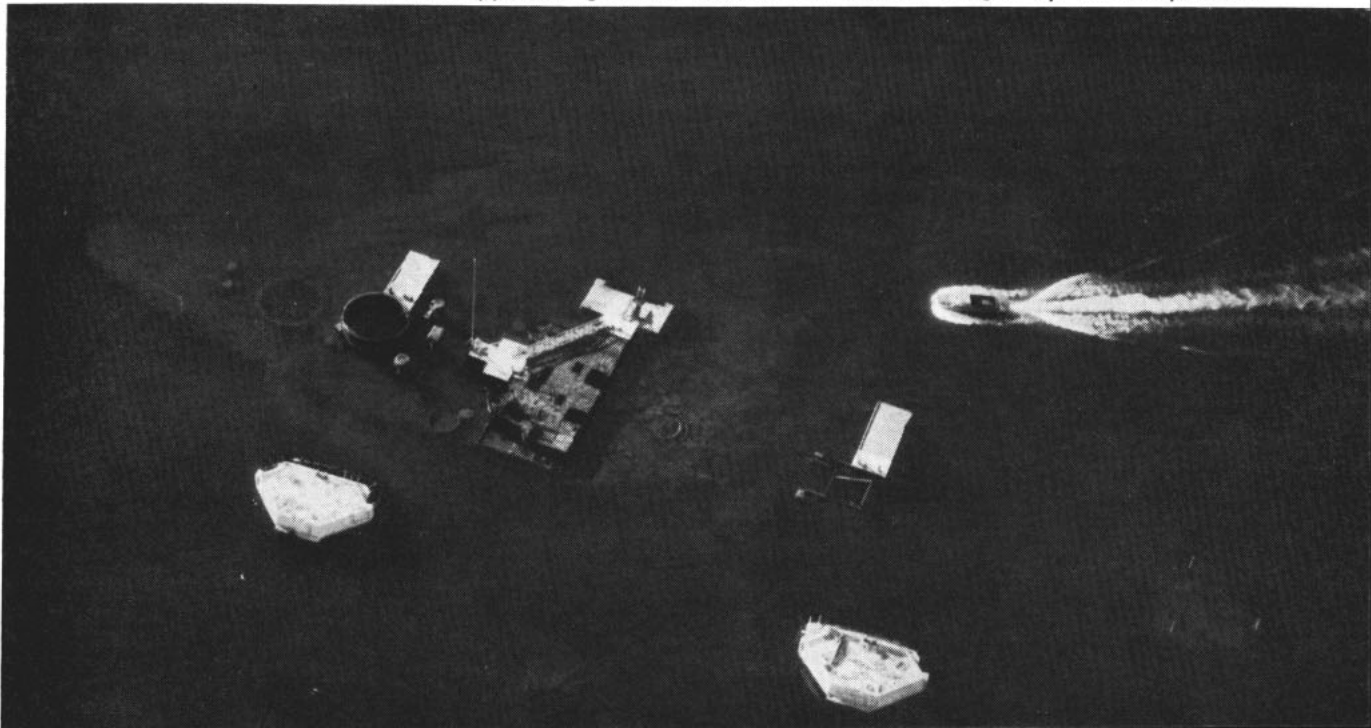

Those Were the Days

We're not quite sure about the majority of our readers, but history holds a special fascination for the members of all ALL HANDS staff. And we're pushovers for the informal, personal, I-was-there variety. Aware of our predilection in this respect, CDR N. R. Fuller, USN, thought of us when, while in Panama not too long ago, the following statement came into his possession.

CDR Fuller tells us that the writer, Bror Hagbord Holmgren, served in the U.S. Navy from 1898 to 1909

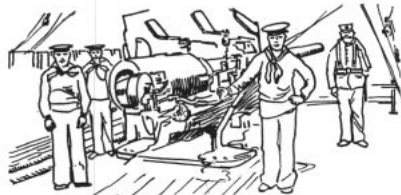

using the more easily pronounceable name of John Harris. The uncle of the wife of a U.S. State Department official, Harris (or Holmgren) lives in Santiago, Chile.

Now over 80, Harris receives a pension as a U.S. Spanish-American War veteran. It is evident that the Navy meant a lot to him.

ON 28 MARCH 1898, I enlisted in the United States Navy as ordinary seaman under the name of John Harris, giving as my birthplace, Helsingborg, Sweden. My place of enlistment was Galveston, Texas, where a recruiting party was temporarily stationed.

I was sent to *uss Franklin* at Norfolk, Va., and from there to the scout cruiser *uss Minneapolis* at Hampton Roads. (*Minneapolis* was considered one of the fastest ships afloat at that time. I'm sure she had the hottest firerooms and burned the most coal.) Shortly after the declaration of war (Spanish-American), we were sent to cruise along the Northeast coast of U.S.A. going as far as Eastport, Maine. Going South, we

were informed of Dewey's victory at Manila by visual signals. We had no wireless then.

After spending some time at Hampton Roads with the rest of the Navy under the command of Commodores William T. Sampson and Winfield S. Schley, we went South alone. We cruised about Cuba and Puerto Rico, and then coaled at St. Thomas. The following morning, we captured the Spanish ship *Maria Dolores* of Balboa just outside San Juan. She was coal-laden from Rio. We put aboard a prize crew and sent her to Charleston, S. C.

SOME DAYS LATER we met the rest of the Fleet outside of Santiago, Cuba, where the Spanish fleet was suspected to be. But our boilers were in such bad shape that we were sent to Newport News where we spent the rest of the war.

After peace was declared, we were sent to Philadelphia, where I was transferred to the auxiliary cruiser *uss Yosemite*.

We towed some John Ericson monitors from around New York to Philadelphia. We also took the modern monitor *uss Amphitrite* from Mole St. Nicholas.

In November, I was transferred to

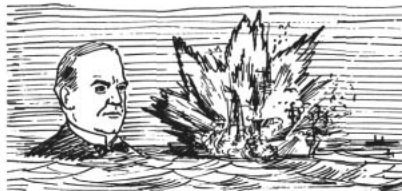

the battleship *uss Massachusetts* at the Brooklyn Navy Yard. On our way out of port, we scraped the bottom near the Statue of Liberty and had to go into drydock, where we stayed until April 1899. Later we joined the Fleet at Newport and went on to Boston where on June 17th, we marched around Bunker Hill—and not for the last time.

Our ship took part in the welcome to *uss Olympia*, and Dewey in *uss New York* and later went to sea in the company of *New York* to test the Marconi wireless. The inventor was on *New York* and his assistant aboard *Massachusetts*. They successfully sent messages 45 miles, which was pretty good for the time.

After the usual cruise and Navy Yard time, we went to Pensacola in March 1901. Going to sea on one of the hotter days, we went aground on a sandbar for about 48 hours. If



we had stayed 12 hours longer, my time would have expired. As it was, I had to go along to Puerto Rico and other points. We arrived at Tompkinsville (Staten Island, N. Y.) April 24th and I was discharged, honorably.

REENLISTED aboard *uss Vermont* at Brooklyn Navy Yard, on 29 July 1901, and a few days later was sent to *uss Franklin* at Norfolk as part of the crew being assembled for the new battleship *uss Illinois*, then being completed at Newport News.

From *Franklin*, I was sent as part of a company to Washington, D.C., to take part in the funeral of President McKinley; where I stood guard in the rotunda of the Capitol as he lay in state. I then joined *Illinois* at Newport News.

Our first mission was the following February, when we hoisted the flag of Admiral R. Evans at Tompkinsville to greet Prince Henry of Prussia. He came in the Imperial Yacht to see Alice Roosevelt break a bottle of champagne on a yacht the Kaiser had built in the United States.



We then went to the Navy Yard to be fitted out as flagship of the European Squadron. When the ship was ready, we broke the flag of Admiral Crowninshield and sailed for Europe. Our first port was Naples and a few days later a small port on the other side of Vesuvius, called Castella di Mar.

Early in June our ship left for England where we assembled at Spithead with all the English Navy and one ship from all other nations' navies. We were to be reviewed by Edward VII after his coronation. This did not take place, however, as the King got sick and could not be crowned.

We went on to Gravesend (England) where we joined the rest of our Squadron which consisted of the cruisers *uss Albany*, *San Francisco*, and *Chicago*. Early in July, the Squadron left for a cruise that was to include visits to Oslo, Copenhagen, Stockholm and Helsingfors.

AS WE WERE entering Oslo's inner harbor, the steering gear failed, and we headed straight for the shore. By going full back and letting go three anchors, (the chains of two broke), we managed to stop before reaching the King's villa. We had some leaks forward and the plates buckled two-thirds of the length. We recovered the anchors, made re-



pairs, and a couple of days later we were visited by Oscar II, who thoroughly inspected ship and crew.

Under our own steam, we went from there to Chatham Dockyard in England, where we were several weeks being repaired.

Next port was Villa Franche in the South of France, from where we sailed to join the Atlantic Squadron.

The following spring we were rammed by *uss Missouri* outside Guantanamo Bay. Our port propeller was damaged, struts were bent and a small hole was punched in the after part of the ship. We limped to Brooklyn, N.Y., and were there several weeks.

WHEN FIT FOR SEA, we went South for our first modern target practice and did very well. The ship as a whole made one of the best scores. I qualified as Intermediate Gunpointer First Class, which I did at all practices in which I took part. After target practice, we joined the rest of the Fleet at Trieste. We re-



turned to the U.S. and made the usual cruise to West India waters.

In July 1905 we waited with other ships off the Virginia Capes to meet the ship which was carrying the remains of John Paul Jones. We escorted it to Annapolis.

While aboard *Illinois*, I served as Coxswain of the gig to Captains George Albert Converse, Royal Bira Bradford and John H. Rodgers. I was discharged on 28 July 1905. On 8 November, I reenlisted in New York.

I went to the Training Station at Newport, R.I., and went aboard the old Frigate *uss Constellation* where I remained until 31 December. I then went to the Seaman Gunner Class at Washington, D.C., and then to the Torpedo Station at Newport.

In October 1906, I graduated as Seaman Gunner and qualified diver. On the 23rd of that month I joined the new cruiser *uss Washington*. Our shakedown cruise was made as escort to our sister ship *uss Tennessee*, aboard which President Theodore Roosevelt (a very fine man) made a trip to Colon.

We then returned to the Navy Yard, where we stayed until May '07. France was next, where we visited La Rochelle and Brest. Our ship returned to the Brooklyn Navy Yard to get ready for our cruise in the Pacific.

WE HEADED SOUTH from New York about 1907, and visited Port of Spain, Rio, and Montevideo. We coaled at Punta Arenas, Callao, Acapulco; had target practice at Magdalena Bay, Lower California; visited some California ports and then went to Seattle, Wash. As we were the first ship named after that state to visit, we were given a great welcome.

Later, together with the rest of the cruiser Fleet, we went to Samoa via Honolulu. From Honolulu we went via Panama and Callao to Talcahuano, Chile. Until this time, the U.S. Navy's major ships had white hulls and yellow upper works. Here, the ships were painted the dark grey which still is the fashion.

After Talcahuano, we spent some days at Coquimbo; spent some weeks keeping peace between Honduras and some neighbor; and then visited San Francisco and Seattle. We put in at the yard where the ship was readied for a cruise East.

I was discharged on 7 November 1909 as Boatswain's Mate second



class—not very brilliant after 11 years. The fault was perhaps, I had opinions of my own which I expressed and defended. My marks on my last discharge were five fives and one four—Five equals 100 per cent.

That was my life in the Navy back in the years around the turn of the century.

—John Harris



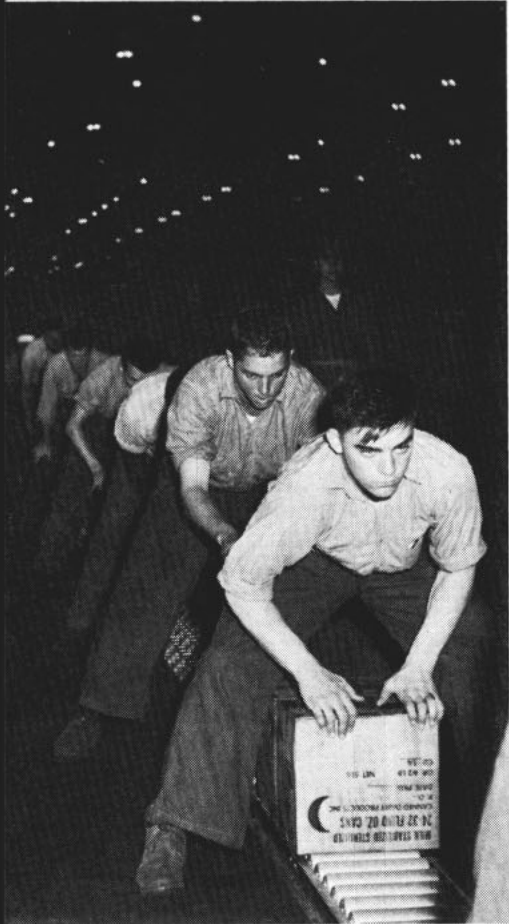

ROLL ON—Cases are stowed away.



ALL HANDS JOB—Transferring supplies by high line underway at sea takes team work from bridge to hold.



MARKET DAY—Supplies are swung to hangar deck of USS *Forrestal* (CVA 59).

Supermarkets at Sea

PERHAPS the only true all hands operation aboard *uss Forrestal* (CVA 59), besides battle stations, is an all-day replenishment at sea. When the carrier striking force of the Sixth Fleet meets the Service Force, Task Force 63, then begins a rigorous day that often runs well into the night.

Forrestal may go alongside as many as five ships in the course of a rendezvous with Task Force 63 to take on fuel, dry stores, frozen goods general stores material and ammunition. Each one of these meetings requires a smooth, close approach regardless of sea conditions, quick securing of lines between ships, and efficient passage of hun-

dreds of tons of goods to the correct space in the correct order.

All in all it takes about 600 men in the working party, not counting the crew on routine work.

The amount of supplies taken aboard a ship always depends on the supply ship itself. For instance, one of the best records achieved by *Forrestal's* crew was during replenishment from *uss Rigel* (AF 58). A total of 340 tons of food, or approximately 15,000 cases, was transferred at sea in three and one-half hours. In three more hours every case was stowed away. The entire operation was conducted on a ready hangar deck with planes throughout ready for immediate use.



ALL HANDS

LETTERS TO THE EDITOR

Instructor Duty Requests

SIR: On 9 Mar 1959 I submitted a request for instructor duty on NavPers Form 1339. Since then I have heard three different theories on the matter, and I would very much appreciate it if you would straighten me out.

One theory is that this type of request is obsolete and will not even be accepted by the Bureau. Another is that I will have to wait until I am on the Seavey list before I can request instructor duty. A third is that the request will be accepted, but not acted upon until I am on the Seavey list.—E. F. L., RM1, USN.

• Although submitting your request on NavPers Form 1339 was not the proper procedure, it was not all wasted effort. Your request will be held in the Bureau and the information used when your name comes up on Seavey.

But, just in case some of your friends want instructor duty, pass the word that NavPers Form 1339 is neither desired nor required by the Bureau.

Procedure for requesting instructor duty at time of submission of Seavey data cards and procedure for change of duty preference to instructor duty subsequent to submission of Seavey data cards are set forth in paragraphs 3 and 5, Enlisted Transfer Manual (NavPers 15909).

No NavPers 1339s, please.—Ed.

Grade Seven Question Mark

SIR: Since the splitting up of the Teleman rating, there has been some confusion over the proper rating abbreviations.

I have been designated Teleman Radioman with a job code of RM 2300. My question is: Am I a TE/RMCA, a TE(RM)CA, a TERCA, or just what?

Although my letter of appointment to E7a used TE/RMCA, local usage is varied. What is really supposed to be correct?—K. D. W., (?), USN.

• The correct title for your "conversion" rating is either Teleman/Radioman (TE/RM) or, in the other direction, Teleman/Yeoman (TE/YN).

In your case, that would make the proper abbreviation TE/RMCA, which is the way they had it in your letter of appointment.

The controlling factor is the rating to which a TE will convert—either Radioman or Yeoman.—Ed.

This section is open to unofficial communications from within the naval service on matters of general interest. However, it is not intended to conflict in any way with Navy Regulations regarding the forwarding of official mail through channels, nor is it to substitute for the policy of obtaining information from local commands in all possible instances. Do not send postage or return envelopes. Sign full name and address. Address letter to Editor, ALL HANDS, Room 1809, Bureau of Naval Personnel, Navy Dept., Washington 25, D. C.

Drawing ComRats

SIR: When I was ordered overseas for a normal tour of overseas shore duty, I was assigned to a commissioned drydock. It is not self-propelled and has been tied up here for years.

Although there is a mess aboard, chiefs eat about 85 per cent of their meals ashore. The BuPers Manual says that the commanding officer cannot grant ComRats to personnel stationed aboard a commissioned ship afloat.

There are three other operating drydocks at the base here, but they are non-commissioned. The men aboard eat at the base mess hall or draw ComRats.

Are there any provisions that will allow us to draw ComRats from aboard this ARD?—C. P. R., SFC, USN.

• Since you are assigned to a commissioned ship of the Navy that operates a general mess aboard, you cannot be authorized commuted rations.

Just as you said, "BuPers Manual," Article A-4404(6), prohibits commanding officers afloat from approving ComRats for enlisted men under their command.

If, however, the afloat command does not operate a general mess, and enlisted men must eat in a mess hall ashore—as you say men aboard those other three ARDs do—the ashore commanding officer may approve ComRats.

That's why they can draw ComRats, and you can't.—Ed.

Dependent Travel via MSTs

SIR: I have been told that dependents who are naturalized citizens can visit their homeland via MSTs on a space available basis. Fact or fiction?—W. A. J. M., ET1, USN.

• Strictly scuttlebutt. Unaccompanied dependents of military personnel on duty within the continental U. S. are not authorized space available travel via MSTs or for that matter on MATS either. Now, if you were to accompany your dependents, that would be a different matter.

OpNav Inst. 4650.4 spells this out in detail. Furthermore, there are no restrictions or special provisions because of a dependent's nationality.—Ed.

Trainee Designator

SIR: I am a graduate from Class "A" Radioman's School under the Navy's conversion program. I have been in the process of changing from EN1 to RM1 since October 1958. Is it too late to change my mind? Is it possible for me to remain an Engineman? I have not taken part in any Fleet-wide examination for advancement to RM1.—J. L. C., EN1, USN.

• As you undoubtedly realize, the Navy has invested a considerable amount of training effort to prepare you for a change in rating to Radioman. This, you will remember, is a result of your request.

Under normal circumstances then, you are expected to fulfill your part of the bargain and continue in the new rating. This doesn't seem an unreasonable assumption.

If your commanding officer considers you incapable of learning the skills of the new rating, however, he may request, at any time, that the "in-service" trainee code be removed. Such recommendations are normally approved.

If you submit your own request for removal of the trainee designator, your letter will be reviewed in the light of your qualifications as reflected by the commanding officer's endorsement, and the training investment which has gone into the rating change thus far.—Ed.

MMs in Subs

SIR: I was advanced in rating to machinist's mate third class last June. I have a sincere desire to serve in submarines. However, I have examined NavAct 2/1959 (Submarine Nuclear Power Training and Fleet Ballistic Missile Submarine Programs) and BuPers Inst. 1540.2C C-1 (Assignment of enlisted personnel to initial submarine training) and note that under both of these I am ineligible because of my MM rating.

Am I out of luck, or is there any other pertinent directive which might enable me to apply for submarine training?—M.J.B., MM3, USN.

• No, you're not out of luck at all. Although the allowance for machinist's mates is small, MMs are now being accepted for basic enlisted submarine school because of increased requirements.

We suggest that you submit a NavPers 1339 requesting such training to the Chief of Naval Personnel via your commanding officer. Good luck, we hope you make it.—Ed.



SALTY START—Ship's bell of USS *Kepler* (DDE 765) became baptismal font for son of BT2 and Mrs. R. B. Hollinger (center) during shipboard ceremony.

Black Shoes for Khaki Uniform?

SIR: In my opinion, the black shoe looks much better with the khaki uniform than the brown one. I wonder if others share that opinion? Has this matter ever been brought before the uniform board, and if so, what was the result?—P. H. F., YNC, USN.

• This question has been before the uniform board, and apparently not enough of your shipmates feel the way you do. This is especially true of the aviation branches, which are particularly anxious to retain brown shoes to wear with the winter working uniform.

Also, while it might be said that since there are other black articles worn with service dress khaki and aviation greens it would not be inappropriate to wear black shoes instead of brown, this would not be the case with the tropical khaki uniform.—Ed.

Training Courses and Schools

SIR: When I was reading Enclosure One to BuPers Inst. 1430.7C, concerning assignment to Navy Schools, I discovered something which I think needs clarifying.

Paragraph 3 b(4) says, "Satisfactory completion of a class 'A' school is considered as meeting the requirements for completion of a training course for the applicable pay grade E-4 rate. However, the Navy training course must be completed for advancement to pay grade E-5."

Must a class "A" school graduate, who has already been advanced to pay grade E-4, complete the Navy training course for third class as well as that for pay grade E-5, before he is eligible to complete for second class petty officer? C. H. J., YN3, USN.

• No. Since you are a graduate of

class "A" school, it is not necessary for you to complete the training course for both E-4 and E-5 to be eligible to compete for advancement to E-5.

That paragraph means you are exempt from taking the training course for E-4 if you are a graduate from class "A" school. When you are ready for E-5, you must complete the training course for E-5 to be eligible.

Since you are already PO3, you are through with the training courses for E-4. In this case, "The training course" does not refer to the previous sentence in the instruction, but stands alone to mean "The training course for the applicable E-5 rating."—Ed.

Railway Sailors

SIR: The article concerning the Naval Railway Batteries which appeared in the July 1959 issue of ALL HANDS was of particular note to some of your readers in Grand Rapids, Mich., because several local men were attached to that activity when it operated in France during World War I.

One item of interest concerning this activity is that it operated with the French army during the war. American sailors, wearing Marine uniforms, were attached to the French army—a really unusual situation.

A framed photograph of one of the railway guns now hangs in the wardroom of the Grand Rapids Naval and Marine Corps Training Center, a gift from the battalion commander whose father served with the railway group in WW I.

The Furniture City Post of the American Legion is a Grand Rapids Legion post whose membership is limited to veterans of the Navy, Marine Corps and Coast Guard. The post uniform is singularly different from the regular

American Legion uniform. The hat, for example, looks much like a French beret, and has a large red pom-pom attached in the center on top. This French influence stems from the fact that several founders of the post had served in France with the Railway Batteries.

Let me express my thanks to you for an extremely interesting article.—A. R. V., LCDR, USNR.

• It frequently happens that an article published in ALL HANDS reminds one or more of our readers of related information unknown to us. This is one of those cases.

Our thanks to you for passing along these added items on what we, too, thought was a very interesting and unusual story.—Ed.

Recruiting Duty for Top Grades

SIR: According to the article in your August issue about the Warrant Officer program being phased out, men advanced to E-9 will be obligated for three years. The article also said that E-9s would take over about one-third of the present WO billets.

This disturbs me. What about an E-9 who wants recruiting duty, is he ineligible under the new policy? And another thing, will E-9s come ashore under Seavey the same as other chiefs, or will they be forced to stay at sea in some WO's billet?

I hesitate to take the examination for E-9 if I am ineligible for recruiting duty, or if I will have to stay at sea for an extended period.—G. W. M., SMCS, USN.

• Have no fear chief. You will be rotated to shore duty under Seavey and you are eligible for recruiting duty.

If you request and are assigned to recruiting duty as an E-8 or an E-9, your application will be handled in the same manner as that of an E-6 or E-7.

Since you are a signalman, you would first be sent to the recruiting school in either San Diego, Calif., or Bainbridge, Md. From school, you'll go to a Navy Recruiting Main Station and be further assigned by the officer-in-charge as a canvasser-type recruiter. (This is the kind that beats the bushes for new recruits.) E-8s and E-9s on this type recruiting duty will fill the same billets to which an E-6 or E-7 would be assigned.—Ed.

Correcting Service Records

SIR: At one time corrections in enlisted service records were made in red ink and initialed by the personnel officer. Was this official, and if so, what authorized it?

Is it also authorized by the current BuPers Manual?—J. J. W., PN1, USN.

• Yes. The red ink corrections were official. "BuPers Manual," (1942, Art. D-4001) authorized them. The authority to initial the corrections could be delegated to the personnel officer, or the changes could be initiated by the CO or exec.

Under the current system, which is covered by "BuPers Manual" (1948, Art. B-2307), the corrections are to be made in black or blue-black ink and initialed by the CO or an officer designated by him.—ED.

Anyhow, Penguins Hold the Record

SIR: In reference to the letter and editorial comment in the August 1959 issue of ALL HANDS relative to "firsts" in Antarctic skin diving, I enclose a photograph taken in 1947 during Operation Highjump in the Antarctic. The divers pictured were a UDT team attached to the central group of Task Force 68. They were, as I recall, under the direction of a LT Iverson, USN.

A repeat performance was staged the next year by a UDT team attached to Task Force 39, and headed by a LTJG Statler.

The photograph is taken from the cruise book of Operation Highjump. It may or may not represent a first.—C. W. M., LCDR, CEC, USN.

• Once burned, twice shy, as the saying goes. We've made a firm resolution—we're not going to make any more claims concerning firsts, lasts, onlys or what have you from now on without documentary proof staring us in the eye.

Even then we'll watch our step—especially in regard to Antarctic skin diving. After all, the Navy was conducting explorations in that area as far back as the 1830s.—ED.



WHO WAS FIRST? Antarctic skin divers pose for picture in ice-filled waters during UDT exercises held as part of Operation Highjump in 1947.

It's Matter of Degrees

SIR: In your August issue there was one statement concerning Kodiak which was misleading, to say the least.

The claim was made that "The climate in Kodiak is comparable to that of the Puget Sound area . . ." Statistics given were that temperatures range from 7 below in winter to a summer-high of 80 degrees, with an average winter temperature of 34 degrees and average summer, 50 degrees. Rainfall was stated as 60 inches annually.

Now consider the same statistics at Seattle, the largest city on Puget Sound. Temperatures range from a low in winter of 25 degrees above to a summer high in the mid-nineties. The average mid-winter temperature is 42.2 degrees; thermometer reading in summer averages 64.2 degrees. And 31.9

inches of rain is the yearly average.

You may compare the Kodiak climate with that in the Pacific Northwest, but not favorably.—F. R., IRO, MSTs.

• We could answer you more effectively if we could figure out whose side you are on—Seattle's or Kodiak's. It's all so relative. After surviving a Washington summer, most ALL HANDS staff members are inclined to be a little less than enthusiastic about any place that boasts "a summer high in the mid-90s." At the moment, a summer high of 80 degrees looks good to us although we may, of course, change our viewpoint again come next January and February.

However, we would like to clarify the record on one point: information concerning the living conditions of various areas, as reported in ALL HANDS is, as a rule, provided by personnel on the scene and forwarded, via the commanding officer, to the Chief of Naval Personnel. The information is then passed on to us. As we mentioned in our introduction, we haven't been to Kodiak—but we can testify that Seattle has some very fine weather, indeed.—ED.



SCRATCH ONE SUB—Escort destroyer USS Waller (DDE 466) launches weapon Alfa, a long-range antisubmarine rocket, during ASW exercise in Atlantic.

Wrong Story

SIR: The Servicescope section of the August 1959 issue of ALL HANDS contained an article entitled "A Three-stage Launching Vehicle." In describing the Vega it stated that "fully loaded it will weigh about 295,000 pounds and will stand as high as a 1-story building."

The breadth of a vehicle weighing that much with a height of only one story would be tremendous. I think that however high 1-story buildings may be in various parts of the world, the height of the fully loaded Vega would be infinitely higher—by a factor of 10, possibly.—W. J. B., YN1, USN.

• You're right, of course—the original copy read "as high as a 10-story building," but somehow a typo in the final version got past everyone.—ED.

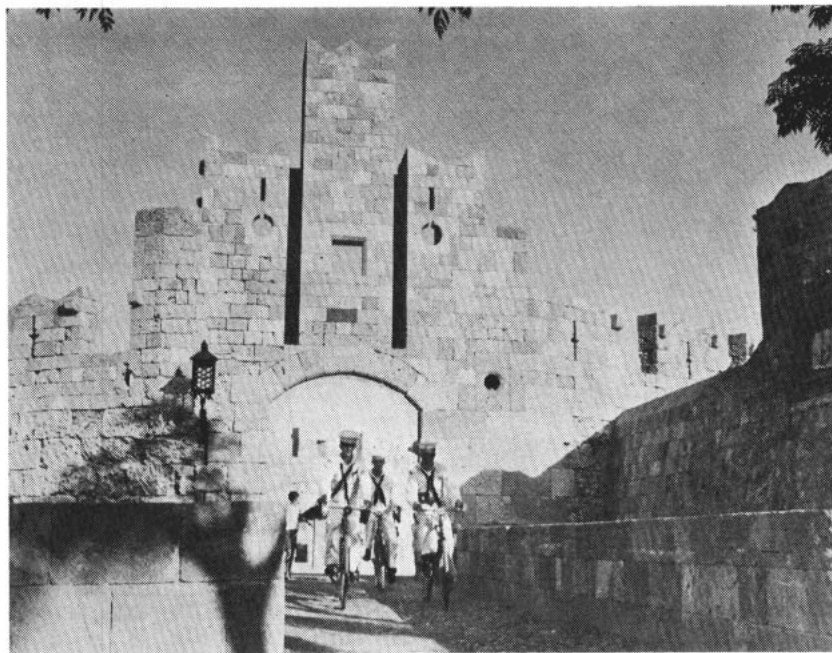

CYCLING GREECE—Sunny country side of Greece is explored with the aid of bicycles by whitehats as their ship makes a stopover at Rhodes.

Uniforms and Brassards

SIR: Articles 1204 and 0113 (3) (d) of *Uniform Regulations, 1951*, leave me confused concerning the wearing of brassards.

On which arm are duty officers—such as Officers of the Deck and Squadron Duty Officers—expected to wear their duty-indicating brassards? Are only shore patrol and beach guard officers supposed to wear the brassard on the right arm?

Are enlisted men serving as Junior Officers of the Watch to be considered "out of uniform" if they wear brassards on the left arm?

Should a watchstander be corrected when he wears a duty or pistol belt so that the letters "U. S." on it appear upside down?

Is a zipper-type working jacket an authorized item of uniform apparel?

In the absence of any specific instructions from his command, which cap cover should a CPO wear while in dungaree working clothes?

Finally, are ownership markings required on the clothing of CPOs?—J. L. M., AECM, USN.

• *The 1951 Uniform Regs were admittedly confusing on the wearing of brassards. However, we think the problem has been cleared up in the new U. S. Navy Uniform Regulations, 1959. The new regulations say that:*

All brassards are to be worn on the right arm.

The Officer of the Day and Junior Officer of the Day on duty at a shore station should wear an "OOD" or "JOOD" brassard, as the case may be.

Officers and enlisted men on shore

patrol or beach guard duty are required to wear an "SP" brassard.

As for your question on the pistol belt, if it's marked it should be worn so that the letters are rightside up. The people who wear it are those on duty as mail clerks, orderlies, guard mail petty officers, officer-of-the-deck's messengers and such.

Yes—zipper type, blue working jackets are authorized. They must be single-breasted, made of water-resistant cotton cloth and lined with nylon fleece. They replace the old, unlined, blue denim dungaree jacket with five metal buttons.

On to the cap covers. A chief in dungaree working uniform may wear either a blue, white or khaki one. The color should conform with that prescribed for the uniform of the day.

Although not specifically required for

Staff Officer Precedence

SIR: We're a little confused. Recent examinations have contained questions about the precedence of staff corps officers. How are persons who normally study *Basic Military Requirements* supposed to arrive at the correct answer when *Basic Military Requirements* (NavPers 10054) Chapter 3, Figure 3-1, lists the precedence in one way, and *Navy Regulations*, Article 1303, lists it another?—D.A.F., PNC, USN.

• *There's a good reason for the confusion—"Basic Military Requirements" is incorrect.*

The correct precedence is: Line, Medical, Supply, Chaplain, Civil Engineer, Dental, Medical Service and Nurse.—ED.

CPOs, it's still a good idea to have your clothing marked. On items which are the same for chiefs as they are for other enlisted men, the location of the markings should be the same.—ED.

Rule on Transfer to Retired List

SIR: I'm confused—unless the law has been changed again.

I recently requested an extension of my overseas duty tour until April 1960. Much to my delight the Bureau went me one better and extended by tour until August 1960.

Now for the confusion—I will complete 30 years' service, day for day, on 10 Jun 1960. The last time I read the law concerning retirement of 1101s, it stated that temps must retire by 30 June of the year in which 30 years' service is completed, or revert.

My question is: Can I stay in the Navy after 30 Jun 1960 as a LCDR, and if so, how long? I'm ready for another 30 years.—J. W. M., LCDR, USN.

• *It's too bad you can't stay another 30. The August date is correct, and it appears that you will be able to complete most, if not all, of your extension at your present duty station.*

Section 1305a, Title 10, US Code, requires that permanent warrant officers, including those who hold a temporary officer grade, be transferred to the retired list on the first of the month 60 days after completion of 30 years' service. The same information is contained in BuPers Inst. 1811.1A, Enclosure (3), Section B.

In your case this means that you will be transferred to the retired list not later than 1 Sep 1960.—ED.

Reenlistee Eligible for School

SIR: I have been trying to get Class "B" IC Electrician School for the last three years. I now have the opportunity under BuPers Inst. 1133.5A, which guarantees me school when I reenlist.

But now I have another problem. I have been told by the personnel office that this situation applies only to those who are reenlisting for the first time.

I disagree. I have read and re-read the instruction and nowhere in it does it say that only first reenlistees are eligible.

What's your interpretation? —R. L. O., ICL, USN.

• *Glad to clear this up. You are eligible for school when you reenlist. The reenlistment for school as an incentive is applicable no matter how many times you have reenlisted.*

Although the instruction you mention has now been superseded by Article 12.8 of the "Enlisted Transfer Manual," the conditions are still essentially the same.

Now that you know you're covered in regard to the reenlistment provision, if you are otherwise eligible for Class "B" School, put in your request.—ED.

What's in a Same?

SIR: On page 24 of your August issue there is a letter in which *uss Neosho* (AO 143) claims a "first" for her at-sea refueling of three ships at once. In your reply you say an old-timer remembered "seeing three ships of COMDESRON 17 refuel simultaneously from the same tanker way back in 1943."

Although the name is the same, the ships are not.

There have been several ships named *Neosho*.

The first was an ironclad which saw action in the Civil War.

Another was AO 23, which was moored at the fuel dock in Pearl Harbor on 7 Dec 1941 and sunk in May 1942 after being damaged in the Battle of the Coral Sea.

The next one was AO 48, which was commissioned in September 1942 and went on to earn 11 battle stars. She was transferred to the War Shipping Administration and disposed of at the end of the war. This must have been the ship you were referring to.

The present *Neosho*, AO 143, wasn't commissioned until September 1954.—James E. Roe, ET2, USN.

• *This just goes to show you how tricky words can be.*

Our old-timer didn't remember the name of the tanker he had seen in 1943, and we still don't know who she was.

When we said, "the same," we were referring to the fact that all three ships had refueled simultaneously from a single (or "the same") tanker—not from "the same" ship the letter writer was talking about.

*As your letter discloses, it is possible to interpret "the same" to mean *Neosho*.*

If it's all "the same" to you, we're going to make a pen-and-ink change in our copy of that issue so the phrase

Ship Reunions

News of reunions of ships and organizations will be carried in this column from time to time. In planning a reunion, best results will be obtained by notifying the Editor, ALL HANDS MAGAZINE, Room 1809, Bureau of Naval Personnel, Navy Department, Washington 25, D. C., four months in advance.

• *uss Arizona* (BB 39)—A reunion of former members will be held at Long Beach, Calif., on 23 Apr 1960. For details, write to William E. Larsen, 4019 West 176th St., Torrance, Calif.

• LCI(L) *Flotilla Two*—A reunion is scheduled for 5, 6, and 7 Aug 1960 at the Hotel Warwick, Philadelphia, Pa. Write to Paul Carter, 804 Fourth Ave., Iowa City, Iowa.

• *uss Capella* (AK 13)—All who served on board during World War II and who wish to hold a reunion with time and place to be decided may write to William Junod, 302 Landis Ave., Oaklyn 6, N. J.

• *uss Cogswell* (DD 651)—All shipmates who are interested in holding a reunion may write to Thomas

D. Castellani, 1013 West 4th St., Pittsburg, Kans.

• *uss Kittyhawk* (AKV 1)—All who served on board and who are interested in holding a reunion with time and place to be decided may write to Henry W. Stix, 2035 Calvin Cliff, Cincinnati 6, Ohio.

• *uss Langley* (CV 27)—All former ship's officers and air group officers who are interested in a reunion in the spring of 1960 may write to R. L. Merkel, M.D., Suite 302, National Reserve Building, Topeka, Kans.

• *36th Special Naval Construction Battalion*—All personnel who served in this outfit on Okinawa in 1945, and who are interested in holding a reunion in 1960, may write to Earl B. Cameron, HMC, USNR (Ret.), 704 Mercantile Library Building, Cincinnati 2, Ohio.

• *29 and 32d Reserve Divisions*, Milwaukee, Wisconsin—All who were assigned to these divisions before World War II and who are interested in holding a reunion late in 1960 may write to Frank Prebezich, 3900 North 88th St., Milwaukee, Wis.

in question will read, "from a single tanker." It's all right with us for you to do the same. Happy now? Good.—The Same Old Ed.

Got His Signal Wrong

SIR: Just recently I finally read a June 1959 issue of ALL HANDS and, after viewing the centerspread with considerable interest, I must admit that I'm confused.

According to NavAer 00-80ZD-1 (a chart showing standard aircraft taxi

signals, which is posted in just about every hangar in the Navy) the emergency stop signal does not correspond with the one you pictured on page 32.

What happened? Have they changed to the old method?—E. S., AD1, USN.

• *Where have you been? The signals used in the centerspread of the June 1959 issue of ALL HANDS were taken from Standard Aircraft Taxi Signals (NAV AER 00-80ZD-1), revised 1959. That poster was issued in January 1951 and has been superseded.—Ed.*

...how to send ALL HANDS to the folks at home

Superintendent of Documents
Government Printing Office
Washington 25, D.C.

ENCLOSED find \$2.50 for a subscription to ALL HANDS magazine, the Bureau of Naval Personnel Information Bulletin, to be mailed to the following address for one year

NAME.....

ADDRESS.....

(For prompt filling of orders, please mail this blank and remittance direct to the Government Printing Office. Make checks or money orders payable to the Superintendent of Documents.

LETTERS TO THE EDITOR (Cont.)

Three or Four Engines?

SIR: The caption for the middle picture at the bottom of page 62 of your June issue has me baffled. It is possible that my perfect record of aircraft identification while training with the Air Force was just plain luck?

Since when was the history-making NC-4 a twin-engine flying boat? I had always thought she had three engines.—A. N. P., ex-USAF.

• *Sorry, but you've just busted up your 4.0 record (and our 1.5 isn't doing so well, either). We asked the man who knows all about such things and he tells us that the NC series did not have two engines (which we should have known), but not all of them had three engines, either. Some had four.*

As we understand the situation, the NCs (there was a total of 10) were originally designed for three engines. However, when the plans for the Atlantic flight shaped up, it was feared that the three engines would not develop enough horsepower, so a fourth engine was added to those planes (NC-1 through NC-4) which were to make the big jump. The propeller of the fourth engine pushed, instead of pulled, as it would in a conventional installation. Unfortunately, this fourth engine is not visible in the illustration to which you refer but the prop of the fourth engine can be seen on the NC-4 on page 48 of that same issue.

In short, NC-1 through NC-4 ended up with four engines; NC-5 through NC-10 with three engines. All clear?

At the moment, we can't think of a good alibi for including the NC-4 in a series of two-engine planes. But give us time. We will.—Ed.

Role of Argentia

SIR: I was very much interested in your "How Did It Start" on Argentia, Newfoundland, on page 53 of the September issue.

However, some confusion arose in my mind.

The article says: "Throughout the war hundreds of railroad tank cars, box cars and refrigerator cars moved from Argentia to the large Army and Army Air Forces installations in Newfoundland."

Correct me if I'm wrong, but I don't believe there's a railroad running out of Argentia—or ever has been. There is one railroad running across the island from St. John's to Port aux Basque and this, I believe, is all.

As for Argentia being an all-winter, deepwater port—free of ice at all times—this may be true. However, I have always been under the impression that St. John's was considered the "year around port" for Newfoundland.

One last item: So far as history is concerned, Argentia played her greatest role when President Franklin D. Roosevelt and Prime Minister Winston

Churchill signed the famous "Atlantic Charter" in Placentia Bay—not far from Argentia.—MSGT C. M. Cowan, USAF.

• *Your mention of the Atlantic Charter meeting is an interesting footnote to the Argentia story. We'll have to dispute some of your other points, however.*

Argentia is served by a rail-line which joins the main St. John's-to-Port aux Basque railway at Placentia Junction—about 25 miles away. Naturally, the railroad to Argentia was a very busy one during the war.

At that time the island's narrow-gauge rail-lines were operated by the Newfoundland Government Railway. The system was made part of the Canadian National Railway when Newfoundland became a province of Canada. Both systems are government-owned.

Our statement that, "Argentia is the only deepwater harbor on the island to remain ice-free throughout the year," is based on information contained in a living conditions report prepared at Argentia and dated March 1959.—Ed.

A Good Shot

SIR: Regarding the "glossy waters" photograph of USS Ranger (CVA 61) and Rowan (DD 782) which invited comment in your letters to the Editor section of the August issue—the unusual brilliance of the picture cannot be attributed to any special photo technique or darkroom chicanery, but rather to a natural combination of bright sunlight and an unusually calm sea. The photograph was one of a series

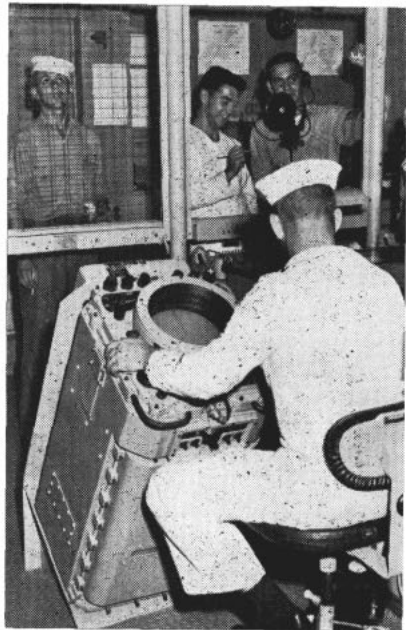

WE'RE HERE—CIC personnel on board USS Ranger (CVA 61) determine the position of their carrier at sea.

shot between Valparaiso, Chile, and Callao, Peru, by C. E. Wall, PH1, of Ranger's Photographic Division during the carrier's cruise from Norfolk to Alameda last year to join the Pacific Fleet.

The camera used was an eight-and-one-quarter inch F-56, loaded with Recco Base Pan. The filter could have been a medium red (25A) or medium yellow. Negative was developed in D-76. Prints were on single weight bromide in D-72.

I have since noted with pleasure that this excellent series of photographs has invited favorable comment by all who have viewed them.—N. O. Keesling, LTJG, USN.

• *There is one point about which there can be no dispute—it was a good picture. Our local self-appointed experts are happy to hear that a filter was used.—Ed.*

Air and Water Temperature

SIR: When I was sitting in the wardroom the other evening my commanding officer hailed me across the table and put forth a few questions for my consideration.

To say that I didn't have the answers at my fingertips would be a gross understatement. In fact, there were none available in the vast reservoir of knowledge accumulated after nearly two weeks at sea.

Here's what I need to know:

1. What is the highest and lowest air-temperature ever recorded by a ship? Where and when?

2. What is the highest and lowest injection-temperature ever recorded by a ship underway? Where and when?

—S. D. T., ENS, USN.

• *Records are records only until some record wrecker wrecks them. Recognizing that someone in the Fleet is always ready to top us, we turned to the U. S. Naval Hydrographic Office, and they gave us facts and figures.*

The Norwegian ship Fram, says Hydro, recorded the lowest air temperature while in the Arctic (frozen in) during the winter of 1893-1894. It was a cold, minus 62° Fahrenheit.

The lowest water temperature was recorded by USS Glacier (AGB 4) in the Antarctic in March 1956. It was plus 28.2° Fahrenheit.

USS Zellers (DD 777) has recorded both the highest air and water temperatures while operating in the Persian Gulf in August 1948. She recorded an air temperature of 130° F and a water temperature of 94° F.

Lower and higher temperatures may have been recorded ashore. As an example, Paul Siple, in his new book, 90° South, reports a temperature of minus 100.4° F at the South Pole. That's somewhat chilly, but, as yet, a ship has not been reported in that area. But there's always tomorrow.—Ed.



Spanish Minemen

MINEMEN at the Charleston naval base have had a Spanish flavor added to their training recently. Two U. S. minesweepers, *uss Bluebird* (MSC 121) and *uss Kingbird* (MSC 194), have been busy passing the word on minesweeping and the operations of an MSC to Spanish navymen who will take over ex-MSC 288 after they become familiar with the handling of this type of minesweeper.

Top left: F. C. Jove, EN2, USN, checks out winch controller during training session for Spanish sailors. *Top right:* Spanish chief boatswain's mate instructs fellow crew member in use of shackles on the fore-castle of *uss Bluebird* (MSC 121). *Right:* Flag bag know-how is passed on to Spaniards by K. P. Hatchell, SM2, USN. *Lower right:* Spanish minemen check stress on minesweeping cable while training to take over MSC. *Lower left:* F. H. Brown, EN1, USN, explains throttle control board to Spanish chief and second class engineman aboard one of the minesweepers.

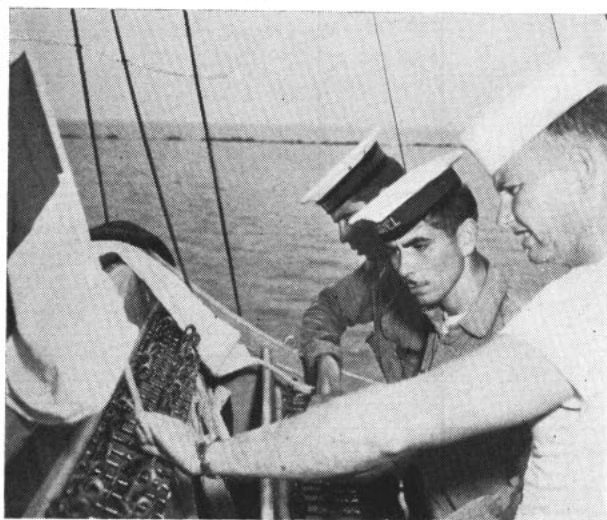

VETERANS BENEFITS BASED

BENEFITS

The purpose of this chart is to show the effect of the type of discharge upon possible eligibility to various rights and benefits.

No attempt is made to set forth other requirements of eligibility which must be met.

***WARTIME SERVICE REQUIRED**

**APPLICABLE
STATUTE
OR
REGULATION**

TYPE OF DISCHARGE

DISHONORABLE
DD Form 260N

BAD CONDUCT
DD Form 259N
(Conditions Other than Honorable)

UNDESIRABLE
DD Form 258N
(Conditions Other than Honorable)

GENERAL
COURT
MARTIAL
CONVICTION

GENERAL
COURT
MARTIAL
CONVICTION

SPECIAL
COURT
MARTIAL
CONVICTION

MISCONDUCT
C-10312

UNFITNESS
C-10311

SECURITY
C-10318A

I. BENEFITS ADMINISTERED BY THE VETERANS' ADMINISTRATION

Benefit	Applicable Statute or Regulation	Dishonorable	Bad Conduct	Undesirable	General Court Martial Conviction	Special Court Martial Conviction	Misconduct	Unfitness	Security
1. Wartime disability compensation*	38 USC 310								
2. Wartime death compensation*	38 USC 321								
3. Peacetime disability compensation	38 USC 331								
4. Peacetime death compensation	38 USC 341								
5. Dependency and indemnity compensation to survivors	38 USC 410, 416								
6. Service pension*	38 USC 510 et seq.								
7. Nonservice connected disability*	38 USC 521 et seq.								
8. Pensions to widows and children*	38 USC 541 et seq.								
9. Medal of Honor Roll*	38 USC 560 et seq.								
10. Hospital and domiciliary care	38 USC 610 et seq.								
11. Medical treatment (including dental)	38 USC 612 et seq.								
12. Prosthetic appliances	38 USC 613								
13. Seeing-eye dogs	38 USC 614								
14. Special housing	38 USC 801								
15. Burial benefits (flag and expenses)	38 USC 901, 902								
16. Vocational rehabilitation*	38 USC 1501 et seq.								
17. Education for Korean veterans*	38 USC 1601 et seq.								
18. War orphans education*	38 USC 1701 et seq.								
19. Home, farm, and business loans*	38 USC 1801 et seq.								
20. Autos for disabled veterans*	38 USC 1901 et seq.								



II. BENEFITS ADMINISTERED BY THE MILITARY DEPARTMENTS

Benefit	Applicable Statute or Regulation	Dishonorable	Bad Conduct	Undesirable	General Court Martial Conviction	Special Court Martial Conviction	Misconduct	Unfitness	Security
1. Mileage	Joint Trav. Reg. ¶4157								
2. Mustering-out payment*	38 USC 2101								
3. Headstone marker (Sec. Army administrators)	24 USC 279a								
4. Payment for accrued leave	37 USC 32 et seq.								
5. Transportation for dependents and household goods	Joint Trav. Reg. ¶3003-1a, ¶7011-5								
6. Burial in national cemetery	24 USC 281								
7. Retain and wear uniform home	10 USC 6297								
8. Notice to employer of discharge	BuPers Man. ¶C-10508								
9. Award of medals, crosses, and bars	10 USC 6249								
10. Admission to the naval home (Enlisted)	BuPers Man. ¶C-9209								
11. Travel in kind	Joint Trav. Reg. ¶5300	✓	✓	✓	✓	✓	✓	✓	✓
12. Cash allowance (\$25)	10 USC 6297	✓	✓	✓	✓	✓	✓	✓	✓
13. Suit of civilian clothes (\$30)	10 USC 6297	✓	✓	✓	✓	✓	✓	✓	✓
14. Board for Correction of Naval Records	10 USC 1552	✓	✓	✓	✓	✓	✓	✓	✓
15. Death Gratuity	10 USC 1480								
16. Navy Discharge Review Board	10 USC 1553								

III. BENEFITS ADMINISTERED BY OTHER FEDERAL AGENCIES

Benefit	Applicable Statute or Regulation	Dishonorable	Bad Conduct	Undesirable	General Court Martial Conviction	Special Court Martial Conviction	Misconduct	Unfitness	Security
1. Homestead preferences (Dept. Interior)*	43 USC 271 et seq.								
2. Civil Service employment preference (Civ. Ser. Com.)	5 USC 851								
3. Credit for retirement benefits (Civ. Ser. Com.)	5 USC 2251(r) et seq.								
4. Reemployment benefits (Sec. Labor)	50 APP. USC 459								
5. Naturalization benefits (U.S. Dist. Courts)	8 USC 1101, 1440								
6. Reclamation project homestead preference (Dept. Interior)*	43 USC 617h								
7. Employment as District Court bailiffs*	28 USC 755								
8. D.C. police, fireman, and teachers retirement credit	D.C. Code Tit 4, §521; Tit 31, §728								
9. Admission to low-rent public housing (PHA)*	42 USC 1402(14), 1410(g), 1415(8)								
10. Housing for distressed families of veterans (HHFA)*	42 USC 1573								
11. Preference in purchasing defense housing (HHFA)*	42 USC 1592a and 1592n(h)								
12. Farm loans (Dept. Agriculture)*	7 USC 1001(b)(2)								
13. Farm housing loans (Dept. Agriculture)*	42 USC 1477								
14. Unemployment compensation and employment service (Sec. Labor)*	38 USC 2007, 2010								
15. Social Security wage credits for W/W II Service (Sec. HEW)*	42 USC 417								

UPON TYPE OF DISCHARGE

TYPE OF DISCHARGE										KEY  ELIGIBLE  NOT ELIGIBLE  ELIGIBLE IF ADMINISTERING AGENCY DETERMINES DISCHARGE WAS UNDER HONORABLE CONDITIONS, OR WAS NOT UNDER DISHONORABLE CONDITIONS, AS APPLICABLE
GENERAL DD Form 257N (Under Honorable Conditions)					HONORABLE DD Form 256N					
CONDUCT C-10312	UNFITNESS C-10311	SECURITY C-10310A	UNSUITABILITY C-10310	MINORITY C-10309	DEPENDENCY OR HARDSHIP C-10308	CONVENIENCE OF THE GOVERNMENT C-10306	DISABILITY C-10305	FULFILLMENT OF SERVICE OBLIGATION C-10304 & C-10317	EXPIRATION OF ENLISTMENT C-10304 & C-10317	

I. BENEFITS ADMINISTERED BY THE VETERANS' ADMINISTRATION

CONDUCT	UNFITNESS	SECURITY	UNSUITABILITY	MINORITY	DEPENDENCY OR HARDSHIP	CONVENIENCE OF THE GOVERNMENT	DISABILITY	FULFILLMENT OF SERVICE OBLIGATION	EXPIRATION OF ENLISTMENT	BENEFIT
✓	✓	✓	✓	✓	✓	✓	✓	✓	✓	1. Wartime disability compensation*
✓	✓	✓	✓	✓	✓	✓	✓	✓	✓	2. Wartime death compensation*
✓	✓	✓	✓	✓	✓	✓	✓	✓	✓	3. Peacetime disability compensation
✓	✓	✓	✓	✓	✓	✓	✓	✓	✓	4. Peacetime death compensation
✓	✓	✓	✓	✓	✓	✓	✓	✓	✓	5. Dependency and indemnity compensation to survivors
✓	✓	✓	✓	✓	✓	✓	✓	✓	✓	6. Service pension*
✓	✓	✓	✓	✓	✓	✓	✓	✓	✓	7. Nonservice connected disability*
✓	✓	✓	✓	✓	✓	✓	✓	✓	✓	8. Pensions to widows and children*
✓	✓	✓	✓	✓	✓	✓	✓	✓	✓	9. Medal of Honor Roll*
✓	✓	✓	✓	✓	✓	✓	✓	✓	✓	10. Hospital and domiciliary care
✓	✓	✓	✓	✓	✓	✓	✓	✓	✓	11. Medical treatment (including dental)
✓	✓	✓	✓	✓	✓	✓	✓	✓	✓	12. Prosthetic appliances
✓	✓	✓	✓	✓	✓	✓	✓	✓	✓	13. Seeing-eye dogs
✓	✓	✓	✓	✓	✓	✓	✓	✓	✓	14. Special housing
✓	✓	✓	✓	✓	✓	✓	✓	✓	✓	15. Burial benefits (flag and expenses)
✓	✓	✓	✓	✓	✓	✓	✓	✓	✓	16. Vocational rehabilitation*
✓	✓	✓	✓	✓	✓	✓	✓	✓	✓	17. Education for Korean veterans*
✓	✓	✓	✓	✓	✓	✓	✓	✓	✓	18. War orphans education*
✓	✓	✓	✓	✓	✓	✓	✓	✓	✓	19. Home, farm, and business loans*
✓	✓	✓	✓	✓	✓	✓	✓	✓	✓	20. Autos for disabled veterans*

II. BENEFITS ADMINISTERED BY THE MILITARY DEPARTMENTS

CONDUCT	UNFITNESS	SECURITY	UNSUITABILITY	MINORITY	DEPENDENCY OR HARDSHIP	CONVENIENCE OF THE GOVERNMENT	DISABILITY	FULFILLMENT OF SERVICE OBLIGATION	EXPIRATION OF ENLISTMENT	BENEFIT
✓	✓	✓	✓	✓	✓	✓	✓	✓	✓	1. Mileage
✓	✓	✓	✓	✓	✓	✓	✓	✓	✓	2. Mustering-out payment*
✓	✓	✓	✓	✓	✓	✓	✓	✓	✓	3. Headstone marker (Sec. Army administrators)
✓	✓	✓	✓	✓	✓	✓	✓	✓	✓	4. Payment for accrued leave
✓	✓	✓	✓	✓	✓	✓	✓	✓	✓	5. Transportation for dependents and household goods
✓	✓	✓	✓	✓	✓	✓	✓	✓	✓	6. Burial in national cemetery
✓	✓	✓	✓	✓	✓	✓	✓	✓	✓	7. Retain and wear uniform home
✓	✓	✓	✓	✓	✓	✓	✓	✓	✓	8. Notice to employer of discharge
✓	✓	✓	✓	✓	✓	✓	✓	✓	✓	9. Award of medals, crosses, and bars
✓	✓	✓	✓	✓	✓	✓	✓	✓	✓	10. Admission to the naval home (Enlisted)
✓	✓	✓	✓	✓	✓	✓	✓	✓	✓	11. Travel in kind
✓	✓	✓	✓	✓	✓	✓	✓	✓	✓	12. Cash allowance (\$25)
✓	✓	✓	✓	✓	✓	✓	✓	✓	✓	13. Suit of civilian clothes (\$30)
✓	✓	✓	✓	✓	✓	✓	✓	✓	✓	14. Board for Correction of Naval Records
✓	✓	✓	✓	✓	✓	✓	✓	✓	✓	15. Death Gratuity
✓	✓	✓	✓	✓	✓	✓	✓	✓	✓	16. Navy Discharge Review Board

III. BENEFITS ADMINISTERED BY OTHER FEDERAL AGENCIES

CONDUCT	UNFITNESS	SECURITY	UNSUITABILITY	MINORITY	DEPENDENCY OR HARDSHIP	CONVENIENCE OF THE GOVERNMENT	DISABILITY	FULFILLMENT OF SERVICE OBLIGATION	EXPIRATION OF ENLISTMENT	BENEFIT
✓	✓	✓	✓	✓	✓	✓	✓	✓	✓	1. Homestead preferences (Dept. Interior)*
✓	✓	✓	✓	✓	✓	✓	✓	✓	✓	2. Civil Service employment preference (Civ. Ser. Com.)
✓	✓	✓	✓	✓	✓	✓	✓	✓	✓	3. Credit for retirement benefits (Civ. Ser. Com.)
✓	✓	✓	✓	✓	✓	✓	✓	✓	✓	4. Reemployment benefits (Sec. Labor)
✓	✓	✓	✓	✓	✓	✓	✓	✓	✓	5. Naturalization benefits (U.S. Dist. Courts)
✓	✓	✓	✓	✓	✓	✓	✓	✓	✓	6. Reclamation project homestead preference
✓	✓	✓	✓	✓	✓	✓	✓	✓	✓	7. Employment as District Court bailiffs*
✓	✓	✓	✓	✓	✓	✓	✓	✓	✓	8. D.C. police, fireman, and teachers retirement credit
✓	✓	✓	✓	✓	✓	✓	✓	✓	✓	9. Admission to low-rent public housing (PHA)*
✓	✓	✓	✓	✓	✓	✓	✓	✓	✓	10. Housing for distressed families of veterans (HHFA)*
✓	✓	✓	✓	✓	✓	✓	✓	✓	✓	11. Preference in purchasing defense housing (HHFA)*
✓	✓	✓	✓	✓	✓	✓	✓	✓	✓	12. Farm loans (Dept. Agriculture)*
✓	✓	✓	✓	✓	✓	✓	✓	✓	✓	13. Farm housing loans (Dept. Agriculture)*
✓	✓	✓	✓	✓	✓	✓	✓	✓	✓	14. Unemployment compensation-employment service
✓	✓	✓	✓	✓	✓	✓	✓	✓	✓	15. Social Security wage credits for WW II Service

★ ★ ★ ★ TODAY'S NAVY ★ ★ ★ ★



SLEEK JOB—USS *Willis A. Lee* (DL 4) has the latest in shipboard design to enable her to carry out mission as long-range Fleet unit and sub killer.

Hi-Fi for the Sonarman

High-fidelity tape recordings are now being used to help sonar operators distinguish the difference between false signals and tell-tale blips of actual submarines.

The new multi-channel tapes are used in a device at the Navy training schools in Key West, Fla., and San Diego, Calif. The Sonar Operators' Target Classification Trainer, as it is called, is linked side-by-side with actual sonar equipment. This allows trainees to monitor all the situations they may encounter at sea.

In addition to recognizing schools of fish which can cast an electronic shadow on sonarscopes, students must learn to identify underwater mountain peaks, old wrecks and even masses of floating plankton or kelp.

Developed under a contract with a civilian concern, the sonar trainer incorporates all types of sonar-

received sounds to enable students to distinguish between actual submarines and non-submarine targets.

Names, Not Numbers

Four landing ships, previously known by number only, now have names of their own.

They are USS *Kodiak* (LSM 161), *Oceanside* (LSM 175), *Lakeland* (LSM 373) and *Raritan* (LSM 540).

LSM 161 and LSM 175 were commissioned in 1944, the latter two the following year. The four are now the only ships of their type in use by the Navy.

LSM 161 is named for, and home-ported in, Kodiak, Alaska. LSM 175, home-ported in Long Beach, Calif., is named for Oceanside, Calif.

The other two, part of the Atlantic Fleet, are home-ported at Norfolk, Va. They are named for Lakeland, Fla., and Raritan, N. J.

Tartar for DDs and Cruisers

Tartar, a supersonic guided missile which will be the primary missile anti-aircraft battery aboard destroyers and secondary missile battery on cruisers, is now in production and will appear in the Fleet next year.

USS *Norton Sound* in recent months has been test-firing the *Tartar* missile off the California coast.

Since space aboard ships is severely limited, the use of miniaturization techniques was required to package the guidance, propulsion and construction systems into the small, light-weight air frame of *Tartar*. The complete missile is about 15 feet long and is slightly over one foot in diameter.

As part of the size-reduction objective, a small-stage, solid-fueled dual-thrust rocket motor was developed. Normally, a two-stage rocket propulsion system is used in this type of missile, the first stage dropping off after it is expended.

The dual-thrust rocket of *Tartar* achieves the same result with a single stage that is an integral part of the missile. A high-thrust, short-duration burning period serves to launch and accelerate the missile to supersonic speed. After this, a lower-thrust, longer-duration burning period maintains this high speed until target interception.

When the missile approaches within range of the target, the warhead is detonated.

Autonavigator

An inertial navigation system that will help to fix precisely the underwater launching position of *Polaris* ballistic missile submarines has successfully completed laboratory testing.

The *Polaris* guidance system must be given precise pre-launching position information in order for the missile to follow an accurate path to its target. This autonavigator, known as the N7A, will provide such information through the use of precision gyroscopes, acceleration-sensing instruments, and a digital computer.

The computer, known, as *Verdan*,

YESTERDAY'S NAVY



On 7 Dec 1917 Battleship Division 9—consisting of USS *New York*, *Wyoming*, *Florida* and *Delaware*—arrived at Scapa Flow to join the British Grand Fleet as the 6th Battle Squadron. On 17 Dec 1862 a Naval Force under CDR J. Alden, cooperating with troops under GEN N. P. Banks, occupied Baton Rouge, La. On 17 Dec 1941 ADM Chester W. Nimitz was assigned to duty as Commander in Chief, U. S. Pacific Fleet. On 20 Dec 1882 Congress authorized the fitting out of a naval squadron to suppress piracy in the Caribbean. On 30 Dec 1941 ADM Ernest J. King became Commander in Chief, U. S. Fleet.

is a general purpose computer plus a "digital differential analyzer." Compressed into approximately one and one-half feet, it can be programmed to permit accurate navigation over all regions of the earth.

Verdan is designed so that its power may be interrupted without loss of stored information. It automatically marks its place in a computation whenever a power failure occurs. It retains the information indefinitely or until power is restored and the computation resumed.

Except for the platform, all of the N7A's electronic equipment is installed in a single, separate navigation console. One control panel contains all the system's controls.

Taking Pictures Under Water

The U. S. Naval Ordnance Test Station, China Lake, Calif., has developed a new underwater camera housing that may overcome many problems met with in deep underwater photography.

The camera housing is three feet in diameter, four feet long, and weighs 1000 pounds out of the water. Submerged, it weighs only 10 pounds and despite its enormous bulk is easy to maneuver.

The new housing is large because it must contain a 35-mm. motion picture camera, heating devices to protect the camera and film, humidity control equipment, and a leak detector.

This last item is most important, since cameras such as this usually stay in the water as long as 24 hours. If a leak does develop, it will be recorded on instruments ashore, and the housing will be brought up immediately.

Since these cameras were designed to use natural light, China Lake technicians have also developed an underwater light meter that works by frequency modulation. It gives off pips that are recorded on shore. As these pips are received, the camera lens may be corrected to obtain the proper exposure.

This underwater equipment is being used extensively at the Naval Ordnance Test Station's sea ranges off the California coast.

San Clemente Island is well adapted to underwater camera research because of its clear water, sandy bottom which reflects the light, and protected coves.

One problem still remains, however. Fish swim right up and look into the camera lens.



'SHIP SHAPERS'—W. E. Krueger, SFC, A. J. Fritz, EM1 (SS) pose with sub.

Citizens Cheer Nautilus Homeported in Minneapolis

Nautilus is doing much to help Navy recruiting in downtown Minneapolis, Minn.

This particular *Nautilus* is not, however, the same ship that went under the North Pole. The one pictured here is just 33 feet long. It appears in the Midwest at parades, fairs and other special occasions.

W. E. Krueger, SFC, usn, and A. J. Fritz, EM1(SS), usn, two Navy recruiters assigned to the Minneapolis Navy Recruiting Station, built *Nautilus* earlier this year. They had hull plans of the real uss *Nautilus*, SS(N) 571, to guide them.

The men completed the 38-foot long, seven-foot wide, steel trailer in mid-January and laid the 33-foot keel of the submarine model

soon after. It was on its way.

Strong plywood forms were attached to the keel. These became the base for the thin plywood hull plating. Black and grey fiberglass was applied to the entire hull and trailer bed which gave the float a permanent color and surfacing.

Krueger and Fritz then added electric motors, horns, sirens, lights, and many other devices. This *Nautilus* can now sound a diving horn; sound a siren; raise and lower its periscope; raise, lower, and rotate its radar antenna; turn its screws; manipulate its diving planes and rudder; and glow with more than 250 lights.

The *Nautilus* float has already logged over 4500 miles and 24 appearances in the midwest.

—LT William D. Folwick, USNR.

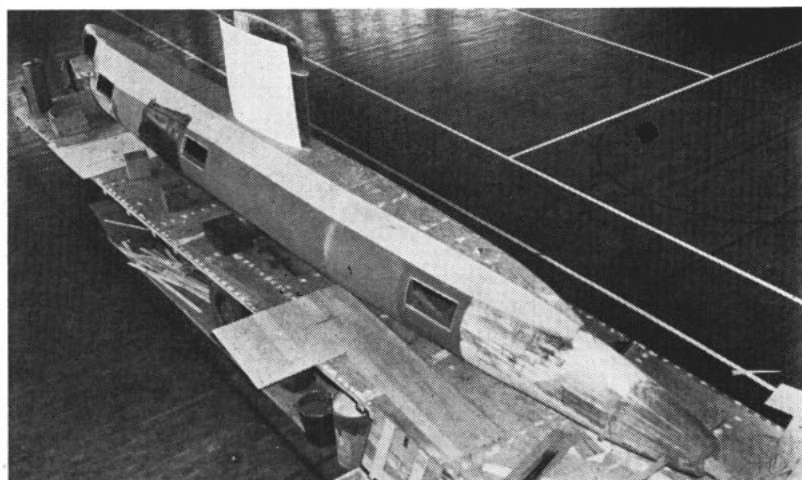

ON THE 'WAYS'—Model of USS *Nautilus*, SS(N) 571, took five months to build. Here plywood skin is nearly ready for black and gray fiberglass.

SERVICE JACKET

As the Navy went about its business:

- Our last non-atomic submarine, *uss Blueback* (SS 581), was commissioned.

- *uss Monticello* (LSD 35), of PHIBPAC, reported that 16 of its crew members received Good Conduct Medals within two months.

- Basic Training Group Three of NAAS Whiting Field won for the second consecutive year CNO's annual Aviation Safety Award in the heavier-than-air propeller class among basic training units.

- For the third successive year, Air Antisubmarine Squadron 27 earned the Battle Readiness Excellence Pennant. In addition, the squadron received the CNO Aviation Safety Award and a Commander Naval Air Force Atlantic Fleet Safety citation for a year of accident-free operations.

- *uss Maury* (AGS 16), the first U. S. Navy ship to visit the Black Sea since 1945, made a transit of the Dardanelles to visit Trabzon, Turkey. An earlier U. S. Navy visit was in 1922.

- A guided missile frigate, DLG 23, is to be named in honor of the late Fleet Admiral William F. Halsey, Jr. Construction is scheduled to begin this year at the Naval Shipyard, San Francisco.

- *uss Bryce Canyon* (AD 36) has won the Battle Efficiency Award for the fifth consecutive year.

- *uss Antietam* (CVS 36) has racked up its 65,000th arrested landing. It was made by Sub-Lieutenant Nils O. Floren, Royal Canadian Navy, who had reported to NAS Pensacola for flight training.

- The guided missile destroyer *uss Charles F. Adams* (DDG 2), which will have the new sea-to-air missile *Tartar* as a part of her armament, has been launched.

- Shortly before *uss Bennington* (CVS 20) pulled into the San Francisco Naval Shipyard for conversion to an antisubmarine carrier, she recorded her 56,000th landing. LTJG Marvin D. Madsen was the pilot.

- *uss Waller* (DDE 466) was host to some 120 dependents and guests during a recent one-day family cruise.

- DESRON six and DESRON 16 are home from the Sixth Fleet. The order of arrival of the returning ships was: *uss Vesole* (DDR 878),

Steinaker (DDR 863), *Zellers* (DD 777), *Bigelow* (DD 942), *Moale* (DD 693), *William M. Wood* (DDR 715), *Allen M. Sumner* (DD 692), *Charles S. Sperry* (DD 697), *Ingraham* (DD 694), *Leary* (DDR 879), *Robert K. Huntington* (DD 781), *Noa* (DD 841), *Meredith* (DD 890), *Massey* (DD 778), and *Stribling* (DD 867).

- While conducting antisubmarine warfare exercises with the Seventh Fleet, *uss Redfish* (SS 395) registered her 5000th dive since her commissioning in April 1944. This averages over a dive a day for every day of the week, except Sunday, over the entire 15-year period.

- Two satellite recovery ships—USNS *Dalton Victory* (AK 256) and *Haiti Victory* (AK 286)—have joined the Pacific Fleet. They will relieve Fleet destroyers now being used to recover satellites launched into the Pacific Missile Range.

- *uss Bonefish* (SS 582) was commissioned at Pascagoula, Miss.

- A *Polaris* test vehicle has been successfully launched from *uss Observation Island* (AG 154), the first launch from a ship at sea.

- CDR Malcolm Ross, USNR, was presented the Distinguished Flying

SEA TO SHORE—USS Floyd County (LST 762) can deliver a big load to the beach during amphibious assault.



Cross for his part in the ONR Strato-lab flight of July 1958.

- *uss Ranger* (CVA 61) has been awarded the Flatley Memorial Award in recognition of her outstanding safety record for fiscal year 1959.

- *uss Providence* (CLG 6) was commissioned at Boston, Mass.

- *uss Paul Revere* (APA 248) and the Naval Communication Facility, Kami Seya, Japan, received the 1959 Ney Memorial Award for outstanding food service operations.

- The P6M *Seamaster* program has been discontinued.

- With one 3-inch gun mount as her sole armament, *uss Takelma* (ATF 113) scored a perfect 100 in this year's competition to earn the right to display a gold "E" for gunnery.

- As one phase of the Military Assistance Program, *MSC 279* has been transferred to the government of Spain.

- Fifteen CPOs formed the first class to complete the NAS Dallas, Tex., Leadership Course.

- *uss Franklin D. Roosevelt* (CVA 42) celebrated her 87,000th arrested landing with a cake to CDR W. J. Gray, commanding officer of VA-15, the pilot.

- *uss Conner* (DD 582), under terms of the Military Assistance Program, has been transferred to Greece.

Record in Flight Safety

Navy flying is getting safer all the time. During fiscal year 1959, the Navy had the safest flight year in its history. This is the seventh consecutive year that the Navy has lowered its own aviation accident rate. The 1959 rate is one-half of the 1953 rate.

Between June 1958 and June 1959, over-all Navy flight operations were 7.2 per cent safer than in the previous year, when an all-time low accident rate had been established. During fiscal 1959, only 2.6 major aircraft accidents per 10,000 flight hours were recorded.

This new record of safety was set despite intensive carrier and other Fleet operations which resulted during the Lebanon and Formosan crises.

It was also the second year of extensive carrier operation of the Navy's new high performance jet aircraft. These new jets had an accident rate safer by 37.9 per cent

over last year. However, increased use of *Forrestal*-class carriers contributed to this reduced accident rate. The landing accident rate for these planes aboard the CVAs was about half that of the small *Essex*-class carriers. There was one fatal landing accident on the large carrier last fiscal year as compared with 10 on the smaller ones.

Many other factors influenced the prevention of accidents which involved Navy blimps, helicopters, seaplanes, and land-based patrol aircraft. The increased installation and use of airfield runway arresting gear has accounted for 340 reported saves.

Another factor cited is improved investigation-reporting procedures and the accident prevention program. The Navy now has a corps of over 600 aviation safety officers who are specifically trained for aircraft accident prevention and investigation.

An ejection seat whereby a pilot can escape from a plane any place from ground level up to all altitudes has also helped save lives.

Even though the average cost of each major accident has increased from \$225,000 to \$340,000 during the last two years, fewer accidents have lowered the over-all dollar losses since last year.

PacFit's Guided Missile Subs

The *Regulus*-launching submarine *uss Growler* (SSG 577) is the Navy's fourth guided missile submarine to be assigned to the Pacific Fleet. She is home-ported at Pearl Harbor with PACFLT's three other missile-launching subs.

Growler was commissioned in August 1958 and is the sister ship to *uss Grayback* (SSG-574) which is also based at Pearl Harbor.

In addition to *Grayback* and *Growler*, the other guided-missile submarines assigned to the Pacific Fleet Submarine Force include *uss Tunny* (SSG 282) and *uss Barbero* (SSG 317). *Growler* reported to Pearl Harbor in September while *Barbero* reported in August. Both were formerly assigned to the Atlantic Fleet Submarine Force.

The *Regulus*-launching *Growler* is 317 feet long and displaces 2400 tons. She is armed with the most advanced operational torpedoes and sonar which enable her to defend herself and perform ASW missions in addition to missile duties.

Navy's Baker Gets a Bungalow in Florida

Baker, the U. S. Navy's space monkey, has moved into her new, specially designed quarters at the U. S. Naval School of Aviation Medicine, Naval Air Station, Pensacola, Fla.

The quarters, designed and built under the supervision of the medical research staff, isolate Miss Baker from contagious diseases, but still allow close surveillance. As the first space monkey, Baker is of great interest to medicine and science.

Miss Baker's home is a stainless steel cage inside quarters that are both air-conditioned and heated.

The cage has a beam of three feet, is three feet high, and measures two feet bow to stern.

On the entrance side of the quarters are two windows, 12 inches by 15 inches. These are one-way windows which allow observers to look in without Baker's being able to see out. To Baker, the windows appear to be mirrors.

Opposite these is a large observation window 36 inches by 52 inches made of regular glass. This allows late afternoon sunshine to enter, and permits Baker to see her visitors.

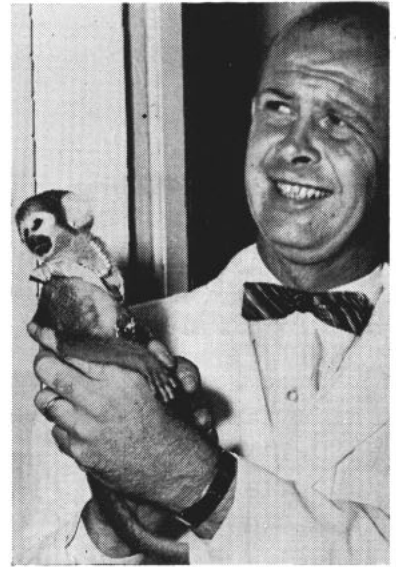

SPACE TRAVELER Baker has a new specially built home at Pensacola.

The new quarters have not only been designed as a home for Baker, but also as a bridal suite. She is due to be married when a suitable husband is selected. At present, one of Baker's girl friends is sharing her new home.

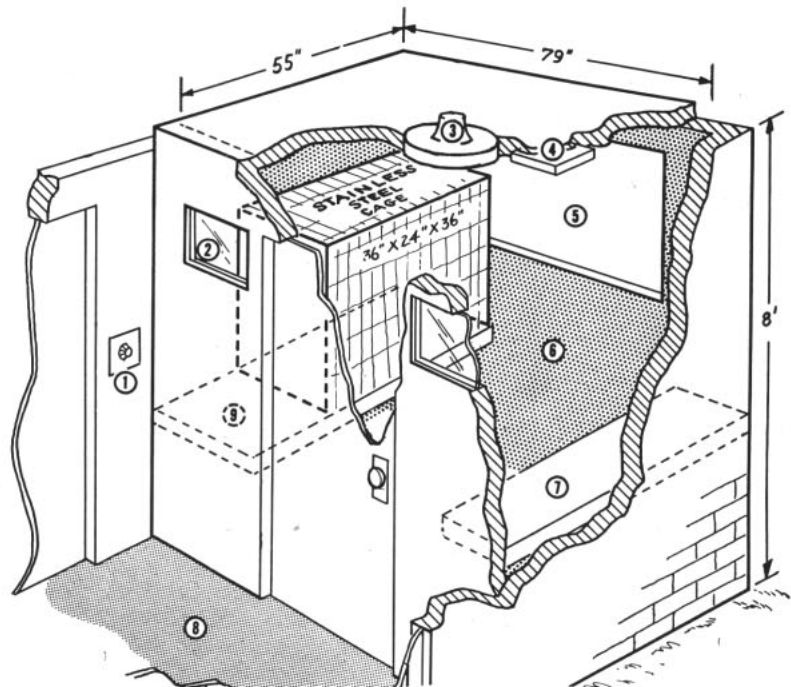

BAKER'S HOME—numbers indicate: (1) Rheostat light control (2) One-way window (3) Ventilator (heating and cooling) (4) Light controlled by rheostat (5) Outside observation window (6) Hard-surfaced, plastic-covered walls and ceiling (7) and (9) Hard-surfaced plastic-covered benches (8) Observation room for Baker.

Deep Diving Parachute Rigger Is a Malacologist

Eleven years of skin diving and five years of combing the ocean floor for shells have turned Chief Parachute Rigger Roland M. Gray into a malacologist.

Chief Gray, a Navyman for 16 years, is now assigned to the survival shop of Air Transport Squadron Eight at NAS Moffett Field, Calif. He began skin diving "just for the experience" more than 11 years ago.

After six years of underwater exploration, he "got tired of looking at fish" and turned to collecting shells. Now, as an avid collector, or malacologist, he has gathered a \$1200-collection.

Although he picks up many types of shells, the chief's main interest is in those of the Cowrie family. The rest he uses for swaps with other malacologists. So far, his exchanges have touched England, Australia and South Africa.

The Cowrie shell is distinguished by its oval shape and high gloss. In its "live" state the shell is covered by the mantle of its inhabitant, the sea snail. (The mantle is a dull-colored fleshy projection that blends with surroundings and makes discovery difficult.) Many such shells are found in coral formations, so it takes a bit of prodding to get them out. For this purpose, Chief Gray carries a crowbar along when he dives.

The chief's favorite specimen is a pure white shell, about four inches long, which has a particularly high gloss. He says this one is so rare that many sea museums and experienced malacologists have never seen it in its natural state. The shell is valued at over \$100. Many of the others in his collection are worth several dollars apiece. The shells range from about one quarter of an inch to six-and-one-half inches in length.

Chief Gray personally dived for most of the items in his collection. However, one shell was found by a dredging crew in 85 fathoms of water, and some of the others were discovered in the stomachs of fish from the coast of Australia.

The chief's collection now includes over 800 specimens. He keeps most of them in a special chest with divided drawers for various categories and species. Of the 165 known



SHELL GAME—R. M. Gray, PRC, poses with some of the 800 cowrie shells he has collected while skin diving.

types of Cowrie shells, Chief Gray has 135 varieties.

Mrs. Gray helped her husband find some of the specimens. She has only one complaint about his interest—"It takes two weeks of just packing shells every time we move."

—Ron Walker, JO2, USN.

The River of 99 Turns

Seaplane tender *uss Salisbury Sound* (AV 13) made her way slowly up "The River of 99 Turns," stuck her bow into a muddy bank, swung her stern around and moored pier-side at Saigon where she was welcomed by thousands of Viet-Nam citizens. Thus began a visit that was one of the highlights of the tender's Far East tour.

About an hour after berthing *Salisbury*, sailors began to hold open house. During the three days in this port over 7000 people visited the ship. Most of these were enthusiastic Vietnamese civilians but several hundred from the country's navy and army came aboard with a friendly welcome and also a keen interest in the running of the ship. Local youngsters were given an extended tour that included cake and ice cream in the crew's mess. Climax of these tours was the visit of the President of the Republic of Viet-Nam, Ngo Dinh Diem, who was received with full honors.

As *Salisbury Sound* pulled away from the pier and the waving crowds, it was with the feeling of parting from good friends and allies after a pleasant visit with the Viet-Name.

Biggest Blimp Yet

Airship Airborne Early Warning Squadron One (ZW-1) based at NAS Lakehurst, N. J., is carrying out some of its AEW detection and tracking missions these days in the biggest blimp ever built.

First airship designed strictly for AEW duties, the ZPG-3W is 403 feet long, 118 feet high, and contains one and a half million cubic feet of helium in her cotton neoprene envelope.

The huge blimp carries a crew of 25 on one-to-two-day patrol missions as a part of the AEW network of the North American Air Defense Command. She's armed with a new radar detection system, the APS 70, which receives signals from the largest antenna ever lofted by any aircraft.

ZPG-3W is powered by two 1500-hp engines, nearly twice as powerful as those used in her predecessors. She is the first of four of her type scheduled to be in operation with ZW-1 by next January.

Davy Jones Gets TV

Underwater television equipment, built for the Bureau of Ships, has now been used in successful ocean bottom surveys at depths of more than 600 feet.

Designated AN/SXQ(XN-2), the new TV system has made it possible for the first time to achieve a continuous, remotely controlled visual survey at such depths. The equipment is primarily designed for salvage and search operations. It includes a closed-circuit television system, an underwater lighting system and a movable camera housing capable of training 70 degrees in any direction.

The camera and its self-propelled unit are remotely controlled via a multi-conductor cable from a control ship. The propulsion system enables the underwater vehicle to hover at any desired depth, despite currents and tides of several knots.

With suitable accessories, the vehicle could be used to collect samples and specimens from the ocean floor, or to retrieve sunken objects.

Built-In Sonar

The Navy has awarded contracts totaling \$30 million to develop and produce a new sonar device for submarines.

The new sonar system will be one of the most comprehensive detection

systems ever devised for underwater craft.

It will form an integral part of the hull design, a new concept in submarine construction. In the past, sonars were fitted into existing hulls. By being built in, the electronic gear not only can be packed into a relatively tight space, but can also be located in the most favorable position on the submarine.

Submarines carrying this new system will be able to locate their targets—both submarines and surface craft—from much longer distances. The new sonars are also expected to add considerable flexibility to submarine tactics. Findings can be relayed to companion sub-killers for coordinated attack, and an attack can be made from a concealed underwater position, eliminating the need to surface to periscope height for visual sighting.

Prop Twisters

Two enlisted men from the attack aircraft carrier *uss Hancock* (CVA-19) represented the Navy in the National Model Airplane Champion Meet at NAS Los Alamitos, Calif.

They were Jack D. Siebenhaar, AQ2, USN, and James F. Certain, AB2, USN.

In the National Meet's control line jet speed class, Aviation Boatswain's Mate Certain served as pitman while Aviation Fire Controlman Siebenhaar piloted his jet-propelled model at 127 miles per hour to take third place. (Top speeds



MODEL AIRMEN—J. F. Certain, AB2, (left) and J. D. Siebenhaar, AQ2, of USS *Hancock* (CVA 19) check winner in National Model Airplane Contest.

were held down during the meet owing to unfavorable weather conditions.)

Siebenhaar also finished sixth in the control line scale model class.

While waiting at NAS Alameda for transportation to Hawaii where the *Hancock* modelers were to rejoin their ship, they took part in another meet held by the Peninsula Prop Twisters of San Mateo, Calif. In this meet Siebenhaar was also

victorious as he flew away with top honors in the control line class.

Siebenhaar, who is president of the "Model Masters"—*Hancock's* model airplane club—has won 12 trophies so far this year. To date, his models have earned him a total of 46 trophies.

Two APDs Inactivated

Two PHIBPAC high-speed transports, *uss Diachenko* (APD 123) and *Begor* (APD 127), have reported to the Pacific Reserve Fleet for inactivation.

Diachenko, commissioned on 8 Dec 1944 at Quincy, Mass., is named for Alex Diachenko, a watertender second class who lost his life attempting to salvage the crippled destroyer *Eberle* in 1943. *Diachenko* was originally built as a destroyer escort. She reported to the Pacific Fleet Amphibious Force in February 1945.

Begor, named for Dr. Fay B. Begor, who was killed in action during the battle of Lae, New Guinea, was commissioned on 14 Mar 1945 at New Orleans, La.

She has several firsts to her credit and a last. She was the first American ship to enter Yokosuka Harbor at the end of World War II and the first ship to enter Haiphong, French Indo-China (*Diachenko* was the last to leave). *Begor* also served in the Bikini atomic tests.

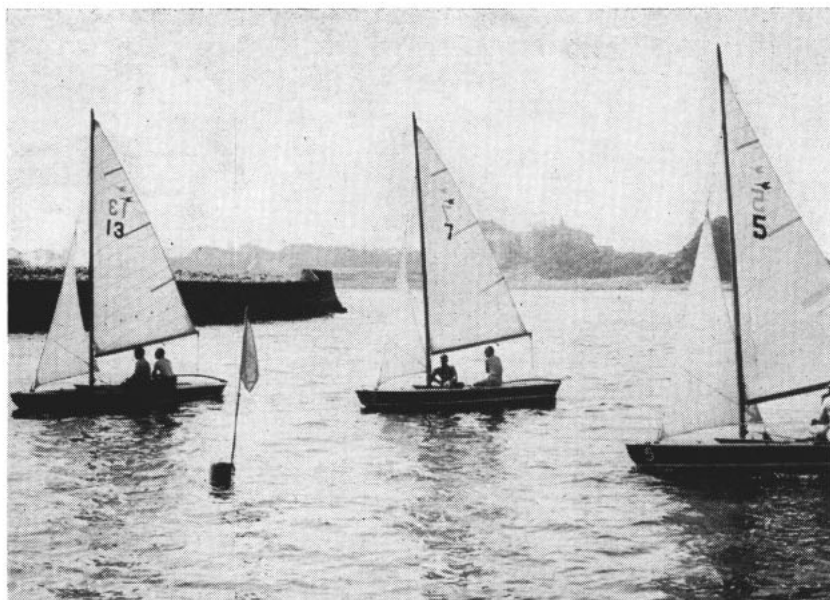

NAVY SNIPERS breeze along during intramural race at Fleet Activities, Yokosuka, Japan, while competing for berth in Yokosuka's championship race.

Roll-on Roll-Off

The new roll-on roll-off shipping technique applied to the transfer of vehicles between ships at sea has proved highly successful during a recent joint Army-Navy test.

Taking part in this operation was USNS *Comet* (T-AK 269), which is assigned to the Military Sea Transportation Service and the Army's radically new lighter, Lt. Col. John U. D. Page.

During these first roll-on roll-off tests, *Comet* and the shallow-draft *Page* maneuvered into a stern-to-stern position and were linked together by a special hinged ramp. Vehicles from *Comet* were then driven onto *Page's* "flattop" deck.

During actual operations, however, *Page* would carry the vehicles to the beach and lower her bow ramp, permitting the vehicles to roll off toward their destinations. This phase of the roll-on roll-off operations had previously been tested and was omitted from the recent deep-water experiments.

The roll-on roll-off technique is being perfected to permit greatly accelerated cargo loading and unloading operations in time of war. In the event of a nuclear conflict, many important ports could be destroyed, necessitating over-the-beach loading and unloading operations.

Comet is the first military ship to be built which employs the roll-on roll-off principle. She is 499 feet long and can accommodate loaded vehicles ranging in size from jeeps to huge semi-trailers.



ROLL OFF—Tank rolls off USNS *Comet* onto flat top deck of Army's beach discharge lighter, Lt Col John U. D. Page, for landing on the shore.

Magnetic Flights

Two Navy planes have begun a series of surveys which will take them some 600,000 miles in flights to gather information for the 1965 world magnetic charts.

One of the planes, a WV-2 *Super Constellation* transport, has already completed a 25,000-mile, month-long survey of the Pacific, and is now circumnavigating the globe. The other, an R5D transport, has completed one round-the-world survey and is now on a second trip.

The Survey aircraft are assigned to Fleet Aircraft Service Squadron 102 at NAS Norfolk, Va. Besides their regular crews, they carry geophysicists from the Navy Hydrographic Office during these flights.

Each plane has a Vector Airborne Magnetometer (VAM), developed by the Naval Ordnance Laboratory to measure the direction and intensity of the earth's magnetic field. In addition, the WV-2 carries an airborne neutron monitor, which provides continuous recordings of cosmic ray intensity.

The flights are part of Project Magnet which is under the technical direction of the Hydrographer of the Navy. Project Magnet is an airborne geomagnetic survey for which the planes will follow tracks spaced about 200 nautical miles apart over all the accessible ocean areas of the world. Where practicable, polar regions and land masses will also be surveyed. Several globe-circling flights over the north and south magnetic and geographic poles are planned.

After the world-wide survey is completed in 1963, intermittent flights will be made over selected tracks to up-date the information.

Project Magnet will provide basic data for practically all United States nautical and aeronautical charts, and will lead to a more complete understanding of the magnetism of the earth. The charted information will be available to the maritime, aviation and scientific communities of the world.

Since 1951, the Hydrographic Office has been directing airborne geomagnetic survey work, and one survey was completed in the North Atlantic before the start of world-wide operations of Project Magnet.

ARMY-NAVY GAME—Navy's cargo carrier *USNS Comet* (AK 269) shows roll-on, roll-off technique with Army vessel.





Sailing Islands

RECENTLY TWO ISLANDS came together in the Arctic Ocean. One was the Fletcher's floating ice island and the other was Navy icebreaker *USS Staten Island* (AGB 5). The traveling island's residents included an Air Force "crew" and representatives of Navy's Underwater Sound Lab.

This marked the first time that the floating scientific research base had been reached by a ship. Previously, all personnel and supplies had been transported to and from the flat iceberg by planes flying out of Alaska and Greenland bases. However, from June to September, softening of the ice and snow runways limits delivery of supplies to these men to air drops.

Purpose of *USS Staten Island's* visit was to deliver a scientist from Navy's Underwater Sound Laboratory to help conduct coordinated under-water acoustic tests of the area. On departing, the icebreaker brought back two members of the island's staff who had completed five months' work there.

The ice island, named after an Air Force officer who was one of its first inhabitants, is a flat-surfaced iceberg

four by 10 miles in size and 150 feet thick. Since its occupation for scientific studies in 1957 it has floated over 800 miles southwesterly and is now about 100 miles north of Canada's MacKenzie River delta.

Top: Island station is photographed from copter. *Right:* Navy scientist is flown aboard icebreaker. *Below:* *USS Staten Island* (AGB 5) moors at ice island.



SERVICSCOPE

Brief news items about other branches of the armed services.

THE U.S. AIR FORCE'S new Air Police Shield, worn on the left breast pocket, will replace the AP arm band.

The new AP badge is a 2½-inch long, 1½-inch wide metal shield. It is made of oxidized silver, and is oval in shape, has a blue and white baked enamel Air Force shield in the center and is surmounted by a spread eagle with a cloud bank background.

Each shield will have a serial number and will be assigned to a specific individual who must return it to the installation Provost Marshal when his tour of duty ends.

There are more than 35,000 Air Policemen and about 1000 Air Police officers in the USAF throughout the world. Each will be issued one of the new shields.

★ ★ ★

A CONTRACT has been awarded for production of a new quarter-ton utility truck that will succeed the jeep as the Army's tactical, commercial and reconnaissance vehicle.

It is lighter than the jeep and rugged enough to be dropped from an airplane. Among its other features are cross-country mobility, low fuel consumption and economy in maintenance.

The vehicle was developed under contract with the Army Ordnance Corps and pilot models have been under test since July 1954.

★ ★ ★

THE NATION'S FIRST PLANE designed for carrying man into outer space, the X-15, has successfully completed its first powered test flight. The X-15 has been under development for the past five years. It is a joint project sponsored by the civilian National Aeronautics and Space Administration, the Air Force and the Navy.

The rocket-powered piloted projectile was released from the wing of a B-52 bomber at an altitude of seven miles. It then soared up to a height of 10 miles above California's Mojave Desert at 1400 miles per hour—which is about twice the speed of sound at that altitude.



NYLON PRINTS—Army has developed three dimensional finger printing, using nylon compound spray to cast.

The hybrid airplane and rocket roared around a 100-mile circle for three minutes. Then it coasted to a landing at the Edwards Air Force Base.

The X-15 is designed to reach speeds as high as 3600 miles per hour and zoom to an altitude of 125 miles—far beyond the reaches of the earth's atmosphere.

The initial test flight was conducted by the builders of the 50 foot X-15. These powered-flight tests will gradually be increased in altitude and speed and the rocket ship will be turned over to the Air Force, perhaps next year.

Before this initial powered-test flight, X-15 had undergone "captive flights" attached to the B-52, and a single free flight. The latter was a glide, without power, from a high altitude to the ground.

The space ship is now powered by an interim power plant consisting of two XLP engines which burn liquid oxygen and a water-alcohol compound. Ultimately, the X-15 will be equipped with a single XLR-99 engine that burns anhydrous ammonia and is several times more powerful than its present power plant.

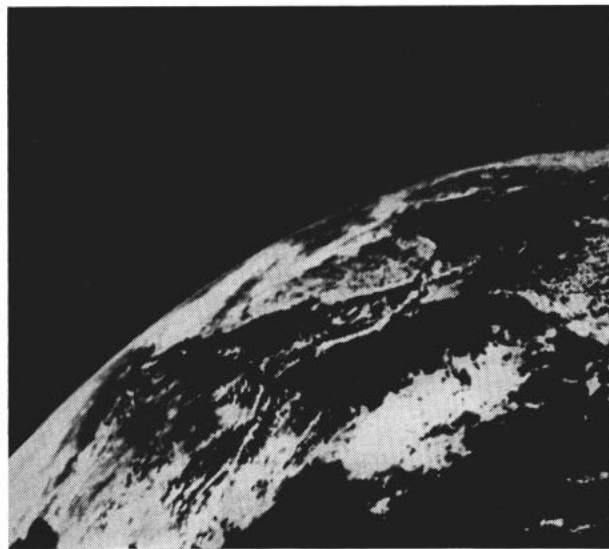

ON HIGH—USAF Atlas photographed earth at 200 miles (left) with main stage dropping, and at 700 miles.

THE ARMY HAS TAKEN THE WRAPS off its newest and largest ship, the 338-foot discharge lighter *Lt. Colonel John U. D. Page*.

Highly maneuverable, this radically new discharge lighter can sail sideways as well as forward and in reverse. It is especially adept in navigating shallow rivers and coastal waters.

Page is the result of years of research in the field of amphibious operations and with an eye to future combat concepts. It was designed to fulfill a need for moving vehicles from ship to shore over unprepared beaches.

This ship has no rudder and is propelled by two six-bladed variable axis propellers. They provide thrust as well as steerage.

★ ★ ★

A CENTRAL LABORATORY TO TEST and evaluate missile inertial guidance systems and components is scheduled to be built for the Air Force's Air Research and Development Command.

This laboratory will be built at the Air Force Missile Development Center at Alamogordo, N.M. When completed in 1963, nearly 350 engineers and technicians will be assigned to the lab.

The individual mechanisms which comprise missile guidance systems will be subjected to intensive examination and testing. These systems depend upon highly accurate instruments which measure the pitch, roll and yaw movements and other factors important to steering aircraft or missiles.

Besides the static lab facilities, the installation will use the 35,000-foot high-speed captive track, the stratosphere chamber and other equipment at the New Mexico Missile Development site to support the missile-systems testing program.

★ ★ ★

A 50,000-WATT NUCLEAR ENERGY REACTOR for biological research and medical treatment is scheduled for installation next summer at Walter Reed Army Medical Center, Washington, D.C.

The reactor, which weighs 450 tons, will be used for biological research and for treatment of patients at the Army hospital. It will be the largest atomic reactor available for treatment of general hospital patients and will produce gamma rays, neutrons, and radioisotopes.

The reactor's fuel solution of uranyl sulphate, highly enriched in Uranium 235, is contained in a 16-inch diameter, stainless steel sphere or core. The reactor core will be installed inside an eight-by-five-by-five-foot stack of graphite "logs" shielded by five feet of high density concrete. Over-all, the reactor will be about 20 feet long, 16 feet wide, and 26 feet high.

It will be self-contained with no harmful particles, fumes or smoke being exhausted into the atmosphere or public disposal systems.

★ ★ ★

HOW DOES IT FEEL TO BE CONFINED in a space capsule less than five feet high and three feet wide?

There are 40 Air Force officers, at the Wright-Patterson Air Force Base in Ohio, who can tell you



STRAIGHT UP—An Air Force Bomarc, long-range air defense interceptor guided missile, goes after target.

just what's what. They recently completed a series of tests to see how man can withstand confinement in a tiny space capsule.

During these tests, the officers worked with psychologists and nutritionists at the Wright Air Development Center to help establish food requirements for space flights and to determine the effects of confined living on humans.

Each of the 40 volunteers spent 48 hours in the capsule, eating prescribed diets and taking various psychological tests.

Some of them lived on a "space diet," consisting mostly of liquids, semi-solids, and bite-size foods, while others dined on a conventional diet of everything from hamburger, baked pork chops, sandwiches, to broiled steak.

The tests enabled psychologists to get a chance to see how a man reacts to the closeness of the tiny capsule.

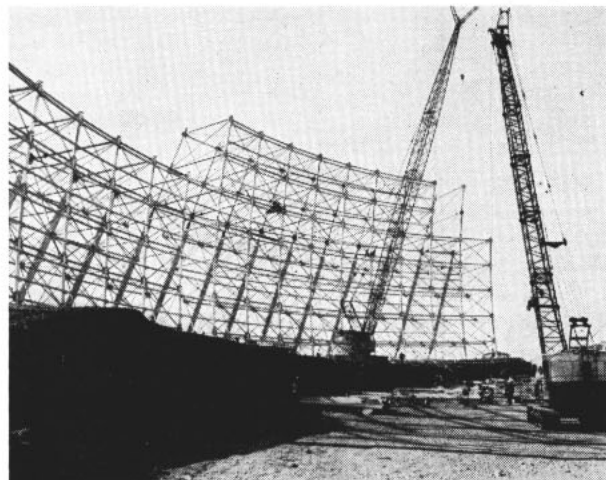

COOL CONSTRUCTION—Army Engineers are building Ballistic Missile Early Warning System for Air Force.

THE WORD

Frank, Authentic Advance Information On Policy—Straight From Headquarters

• **INITIAL SUBMARINE TRAINING** is now available to Machinist's Mates in all pay grades. Other rates needed for basic submarine training include Electrician's Mates, Enginemen, Electronics Technicians, Interior Communications Electricians, Sonar-men and Torpedoman's Mates in all pay grades.

Men in the EN, MM, IC, ET and EM ratings are needed particularly for basic and advanced training leading to eventual assignment in nuclear submarines.

These changes were announced in a memorandum change to the Enlisted Transfer Manual. They are the result of the expansion of the Navy's Nuclear Power and Fleet Ballistic Missile Submarine Programs that are now under way.

• **SKY DIVING, ANYONE?** — If you're a sky diving enthusiast, interested in forming a club to help popularize the spread of this exciting sport at your base, you'll get plenty of official backing.

Before you rush out to price used parachutes, or start badgering the operations department for the use of a plane, there's one important visit you should make—to your Base Administrative Office for a copy of SecNav Inst. 1700.6.

This instruction authorizes and encourages Navy participation in sky diving—or competitive parachute jumping, to give it its official designation—so long as it is properly planned and supervised.

It outlines extensive rules and regulations governing eligibility, establishment of clubs, use of Navy equipment and aircraft, safety pre-

cautions as well as the command responsibility.

• **DRAFTSMAN, SURVEYOR RATINGS** are being streamlined to bring them more in line with the demands of today's Navy.

Draftsman, which was a general service rating, has been changed to Illustrator Draftsman (DM) and is now a general rating for all pay grades. Under this revision, all five of the DM emergency ratings have been dropped.

In the new Illustrator Draftsman (DM) rating, emphasis will be placed on illustrative skill and knowledge as well as the previously required working know-how of basic mechanical and electrical drafting.

The general rating of Surveyor (SV) has been changed to Engineering Aide (EA) for pay grades E-6 through E-9, while two new service ratings—Engineering Aide D (Draftsman)—EAD, and Engineering Aide S (Surveyor)—EAS, have been established for pay grades E-4 and E-5.

The new EA ratings will include those skills and knowledges related to surveying, as well as those that concern structural, topographical, and construction drafting; materials testing, and materials estimating.

The initial input into the new EA ratings will come from personnel now in the SV rating and those of the DM rating that are experienced and assigned to activities of the Naval Construction Force.

The normal path of advancement for Illustrator Draftsmen from enlisted to officer status will be to Limited Duty Officer, Administra-

tion; while the Engineering Aides will go to LDO in the Civil Engineering Corps.

• **FEBRUARY EXAMS**—Before you make any big plans for February 1960, chances are you'll want to check the dates of the service-wide examinations for advancement in rating. So—just in case you haven't already marked your calendar—here is the schedule:

For Advancement

to:	Day	Date
CPO	Tuesday	2 Feb
PO3	Thursday	4 Feb
PO2	Thursday	9 Feb
PO1	Thursday	11 Feb

The exam dates were announced in BuPers Notice 1418 of 27 Oct 1959. According to that directive the February exams will involve a number of changes in such administrative matters as the ordering of examinations, processing and the submission of returns. Most of these changes are associated with the adoption of punched card examination materials and the installation of electronic computers at the Naval Examining Center to process exams more accurately and rapidly.

Inaugurated in August 1959, the punched card system enabled the Examining Center to announce the results of the August exams a month earlier than had been possible with previous methods.

Besides calling for changes in administrative procedures, BuPers Notice 1418 contains three items of particular interest to Navymen in the ratings mentioned below.

The first concerns service school requirements for advancement, which will be as follows for these rates:

PR3—Parachute Riggers Survivalman, Class A, or Parachute Riggers, Class A.

PT (all grades)—Photographic Interpretation School, or Photo Reader Course at a Fleet Air Intelligence Training Center.



"YOU CAN BE Santa Claus to nine other Navymen by passing ALL HANDS on to those who are waiting for it."



"Our new hand bomb has just been proven successful."

HM3—Hospital Corps School, Class A.

DT3—Dental Technician School, Class A.

MUCA—Advanced Music, Class B.

AGCA—Aerographer's Mate, Class B.

The second item is a reminder that these service rates within the Sonarman rating were established under BuPers Notice 1440 or 20 Mar 1959—SOG (Sonarman, Surface); SOS (Sonarman, Submarine); SOA (Sonarman, Airborne); and SOO (Sonarman, Oceanographer). Only seaman are eligible to compete for advancement to SOG3, SOS3 and SOO3. However, both seaman and airman may compete for SOA3.

● **LONGER SHORE DUTY TOURS FOR SOME RATINGS**—Eleven ratings in Seavey Segment One (1960) will get longer shore duty tours under a recent readjustment of shore tours.

Segment One ratings will start to receive orders to shore duty in Feb 1960 (see ALL HANDS, Nov 1959, page 45.)

Ratings affected by the readjustment are:

Rating	Old Tour (Mos.)	New Tour (Mos.)
NWC	24	30
MNC, 1	36	42
GSC, 1, 2	30	42
ETC	30	36
RMC	24	30
DMC, 1, 2	36	48

Increases in normal tours of shore duty are effective for all personnel in the above listed ratings whose current shore tours expire 1 May 1960 or later, or who report for a normal tour of shore duty after 31 Aug 1959.

Continuing readjustments of normal tours in all ratings are contemplated until tours ashore support the average minimum sea tour of approximately three years.

Present normal tours of shore duty in all ratings are:

Rating	(Mos.)	Tour Length	Rating	(Mos.)	Tour Length
BMC	30		PMC	30	
BM1, 2, 3	24		PM1, 2, 3	24	
QMC	30		MLC	30	
QM1, 2, 3	24		ML1, 2, 3	24	
SMC	30		CEC	30	
SM1, 2, 3	24		CE1, 2, 3	24	
RDC	30		EOC, 1, 2	30	
RD1, 2, 3	24		EO3	24	
SOC	30		CMC, 1	30	
SO1, 2, 3	24		CM2, 3	24	
TMC	30		BUC	30	
TM1, 2, 3	24		BU1, 2, 3	24	
NWC	30		SWC	30	
NW1, 2, 3	24		SW1, 2, 3	24	
MNC, 1	42		UTC	30	
MN2	36		UT1, 2, 3	24	
MN3	42		ADC, 1, 2	36	
GSC, 1, 2	24		AD3	24	
GS3	24		ATC, 1, 2	30	
ETC	36		AT3	24	
ET1, 2	30		AOC	30	
ET3	24		AO1, 2, 3	24	
IMC	30		ACC, 1, 2	36	
IM1, 2, 3	24		AC3	24	
OMC	30		ABC	36	
OM1, 2, 3	24		AB1	30	
RMC	30		AB2, 3	24	
RM1, 2, 3	24		AEC	30	
YNC, 1, 2	48		AEL, 2, 3	24	
YN3	24		GF1, 2	36	
PNC, 1, 2	48		GF3	24	
PN3	24		AMC, 1, 2	30	
SKC	30		AM3	24	
SK1, 2, 3	24		PRC	36	
DKC, 1	36		PR1, 2	30	
DK2, 3	24		PR3	24	
CSC	30		AG1, 2	36	
CS1, 2, 3	24		AG3	24	
SHC	30		TDC, 1, 2	36	
SH1, 2, 3	24		TD3	24	
JOC, 1, 2	48		AKC, 1, 2	36	
JO3	24		AK3	24	
DMC, 1, 2	48		PHC, 1, 2	36	
DM3	24		PH3	24	
ENC	30		HMC, 1	42	
EN1, 2, 3	24		HM2	30	
MRC	30		HM3	24	
MR1, 2, 3	24		DTC, 1	48	
ICC	30		DT2	30	
IC1, 2, 3	24		DT3	24	
DCC	30		SDC	30	
DC1, 2, 3	24		SD1, 2, 3	24	

The change to the *Enlisted Transfer Manual* which announces the readjustment of shore duty tours, also reminds commanding officers that it is necessary to prepare diary entries for all personnel eligible for readjusted tours.

Failure to include a corrected shore tour completion date into the manpower information system will result in men receiving orders at the completion of their old tour date.

For further information on the February exams, see BuPers Notice 1418 of 27 Oct.

If you saw the uniforms in last month's issue and reviewed the 1959 issue of *Uniform Regulations*, you should have no trouble answering the first two questions in this month's quiz.

1. Large medals are worn with (a) service dress uniforms, (b) full dress uniforms, (c) evening dress.

2. Ribbons may be worn instead of medals with (a) service dress uniforms, (b) full dress uniforms, (c) tropical white long uniforms.



3. This team of Navy men is ready to "stream gear." The float they are putting over the side is called a/an (a) "oscar," (b) "pig," (c) "banana float."

4. They are preparing to (a) moor their boat, (b) recover torpedoes, (c) sweep mines.



5. The insignia shown above is that of an Air Force staff sergeant which is in the same pay grade as a Navy (a) PO1, (b) PO2, (c) PO3.



6. The Marine Corps is represented by the insignia shown here. It denotes (a) staff sergeant, (b) gunnery sergeant, (c) first sergeant.

You'll find the answers to this month's Quiz Aweigh on page 57.



THE BULLETIN BOARD

How to Request Duty to New Construction and Conversion Ships

THE NAVY CURRENTLY has approximately 70 new ships, exclusive of submarines, that are actually under construction, 15 more being converted to other types or for special duties and many more authorized to be built or scheduled for conversion.

These ships range from tiny coastal minesweepers to nuclear-powered guided missile frigates and destroyers, to gigantic atomic aircraft carriers. And before too long, these new and converted ships will need crews to man them.

In this respect, have you ever wondered just how a new or converted ship gets its crew or how you would go about requesting assignment to one of them?

Well, whether you have thought about it or not, here's the scoop.

The officer and enlisted personnel who comprise the crews of new construction/conversion ships are nor-

All Navy Cartoon Contest
A. B. Castro, SA, USN

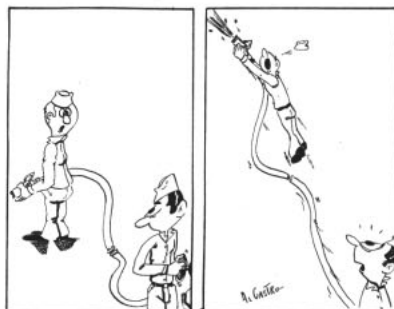

mally ordered in two general groups—the nucleus crews reporting to the building or conversion yard and the balance of the crew to a Fleet training center for precommissioning training.

The nucleus crew of key petty officers (approximately 20 per cent

of the ship's allowance) normally reports to the naval activity in the vicinity of the shipyard some 10 weeks in advance of the completion or commissioning date. A large percentage of supply and engineering personnel are usually included as part of the nucleus crew.

During the precommissioning period, these men assist in assembling the precommissioning outfit and witness tests of machinery and equipment. They learn the techniques of reactivation if their ship is to be reactivated. They also become familiar with the details of operation of the ship and its equipment and they serve as on-the-job instructors for the balance of the crew as it reports.

The rest of the crew is usually ordered to a Fleet training center for precommissioning training of approximately four weeks or 20 days of instruction. This is normally scheduled to permit them to report aboard one week before commissioning date.

(Precommissioning training is officially defined as "the organizing and training of crews for ships scheduled to be activated, converted, or newly constructed, so that they may satisfactorily undergo shakedown training after commissioning. Peacetime precommissioning training serves the additional purpose of establishing the procedures that will be used in times of national emergency.")

The entire crew for new construction and conversion ships are detailed by the Fleet commanders from Fleet sources. However, the Chief of Naval Personnel coordinates these assignments. Approximately seven months before the actual commissioning date, the Chief of Naval Personnel issues a directive to EPDOLANT or EPDOPAC as appropriate.

All this is very fine, but just how do you go about getting assigned to a new or converted ship?

If you are now serving ashore, you may indicate your preference for a specific new ship or one that is being converted when you fill out your Shorvey data card. However, in doing so, you must consider the

Ships Undergoing Conversion and New Construction

Here's a list of new ships (exclusive of submarines), as well as those being converted that are currently scheduled to be commissioned within the next year. If you are interested in being assigned to any one of them, see story above for further information.

NAME AND TYPE OF SHIP	LOCATION OF BUILDING YARD	
NEW CONSTRUCTION:		
USS Long Beach, CG(N) 9	East Coast	September 1960
USS Kitty Hawk (CVA 63)	East Coast	November 1960
USS Charles F. Adams (DDG 2)	East Coast	September 1960
USS John King (DDG 3)	East Coast	December 1960
USS Lawrence (DDG 4)	East Coast	November 1960
USS Henry B. Wilson (DDG 7)	East Coast	November 1960
USS McMorris (DE 1036)	East Coast	March 1960
USS Farragut (DLG 6)	East Coast	April 1960
USS Luce (DLG 7)	East Coast	August 1960
USS Macdonough (DLG 8)	East Coast	November 1960
USS Coontz (DLG 9)	West Coast	July 1960
USS King (DLG 10)	West Coast	November 1960
USS Mahan (DLG 11)	West Coast	October 1960
USS Dewey (DLG 14)	East Coast	December 1959
USS Preble (DLG 15)	East Coast	May 1960
USS Albatross (MSC 289)	West Coast	July 1960
USS Gannet (MSC 290)	West Coast	September 1960
CONVERSIONS:		
USS Proteus (AS 19)	East Coast	June 1960
USS Currituck (AV 7)	East Coast	August 1960
USS Little Rock (CLG 4)	East Coast	March 1960
USS Oklahoma City (CLG 5)	West Coast	July 1960
USS Springfield (CLG 7)	East Coast	March 1960
USS Topeka (CLG 8)	East Coast	April 1960
USS Coral Sea (CVA 43)	West Coast	January 1960

prospective commissioning date of that particular ship in relation to your date of availability for transfer to sea duty.

If you are at sea, you can apply when your Force Commander calls for volunteers or nominations. When the Chief of Naval Personnel issues a directive to EPDOPAC or EPDOLANT, as described above, they in turn request the Force Commanders to provide the required personnel for the ship. The Type Commanders normally fill these billets from volunteers within their particular commands or from already established waiting lists.

As an example, let's take the case of the destroyer *USS Turner Joy* (DD 951), recently commissioned at Seattle, Wash. Last January, about seven months before her scheduled commissioning, the Chief of Naval Personnel issued a directive to EPDOPAC stating *Turner Joy* requirements. Upon receipt of this order, EPDOPAC in turn asked COMCRUDESPAC to provide the personnel needed to make up *Turner Joy's* crew. As *Joy* was built on the West Coast, it was EPDOPAC's responsibility to provide all ratings required for the nucleus and the balance of her crew except special detailed personnel furnished by the Bureau.

The crews of new constructions or conversions usually come from the Fleet depending upon the coast on which the ship is being built or converted. *Joy's* crew came from PACFLT because she was built on the West Coast; the attack aircraft carrier *Kitty Hawk* (CVA 63), being built at Camden, N. J., will receive her crew from the Atlantic Fleet even though she is ultimately scheduled to be assigned to the Pacific Fleet.

If you are interested in being assigned to a new ship now under construction or one that is being converted, check the listing (on page 00) of ships scheduled to be commissioned within the next year.

Scholarship Is Offered for Candidates Applying for USNA

The Naval Officers' Wives' Club of Washington, D. C., will award a self-aid scholarship grant in 1960 to a student between the ages of 16 and 20 years who wishes to prepare for entrance to the U. S. Naval Academy and become a career naval officer.

The grant of at least \$500 will be made on the basis of need, mental and physical superiority, qualities of leadership, and evidence of a sincere desire to make a career in the Navy.

The money must be used for the recipient's work during his senior year in secondary school (or for post graduate secondary school work) and for other expenses in connection with academic preparation for the Naval Academy. The school he attends must be recognized by the U. S. Navy as giving adequate preparation for a person's entrance to the Academy.

A doctor's certificate must be submitted that shows the applicant is fully qualified to pass the physical

examination for entrance to the U. S. Naval Academy.

The recipient will be selected by a Scholarship Selection Committee appointed by the Naval Officers' Wives' Club. Payment of the grant will be made directly to the approved school of the recipient's choice. It is a one-year grant and may not be renewed.

Applications are available from, and should be returned to, the Dependents Aid Section, Pers G221, Personal Affairs Division, Bureau of Naval Personnel, Washington 25, D. C.

Applications for the current award must be received by the scholarship committee before 20 Apr 1960.

WAY BACK WHEN

Naval Propellant Plant

The present U. S. Naval Propellant Plant at Indian Head, Md., had its origin as The Naval Powder Factory in 1898. The plant has remained in continuous operation since the first smokeless powder was produced there in June 1900.

In those early days, the Powder Factory was not the only facility at the Naval Station, Indian Head. In 1890 the Naval Proving Grounds had been moved there from Annapolis.

It wasn't long after production started at the Powder Factory that it became evident more space would be needed. In 1901, 1050 acres of adjoining land, known as Stump Neck, was added to the original 880 acres.

Five years later a sulfuric and nitric acid plant was added, and in 1907 a new powder reworking factory began operations.

Powder production and the testing of guns went their separate ways in 1921. The Naval Proving Grounds was moved to its present location at Dahlgren, Va. Eleven years later, in July 1932, the Naval Powder Factory became an independent command.

Just before the beginning of World War II, in 1940, the National Research Council established a Jet Propulsion Research Unit there. This group developed the now famous bazooka as an anti-tank weapon.

This was the beginning of the change from powder to propellants. In July 1943, the Ballistics Laboratory was opened to test ballistite grains.

Two years later, the million-dollar Research and Development Laboratory was completed. It was equipped with the most modern machinery for perfecting new explosives.

Patterson Pilot Plant, a factory for manu-

facturing experimental powder in small quantities, was added in 1949.

Later, four more plants began producing solid propellants:

- The *Cast Propellant Plant*, which began operating on 16 Nov 1953, is a large-scale unit which produces solid cast propellants for missiles.

- The *Biazzi Panel Nitroglycerin Plant* has been producing 'nitro' for double-base, multi-base, and cast-type solid propellants since 23 Apr 1954.

- On 23 June 1954 the *Nitroguanidine Plant*, which produces nitroguanidine for multi-base propellants, began operations.

- The *Cordite "N" Plant*, which makes cool-burning propellants, went into operation six weeks later. The plant is now being used to develop plastisol nitrocellulose propellants and nitropolymers.

To reflect its present products better, the name of the plant was changed in August 1958 to U. S. Naval Propellant Plant.



Here Are the Factors Deciding Whether You Will Draw Pro-Pay

YOU HAVE just finished competing for proficiency pay. Only time and the Naval Examining Center grading your exams can tell whether or not your pay will increase by \$30 a month starting 16 Jan 1960.

If you are a career third or second class petty officer in any one of 44 critical ratings, your chances are good. (See the table below for actual number in each rating that may be awarded proficiency pay. Remember, third and second class petty officers will get the biggest slice.)

Under a recent revision of the pro-pay regulations, career personnel who pass the test will be in line to get the extra money first. The remaining allocations will go to non-career men who pass. For proficiency pay purposes, career personnel are those who have served, or are obli-

gated to serve seven years' active duty.

Eighty-five per cent of all pro-pay will go to men in ratings which require long periods of specialized schooling or in-service training; require special technical or leadership aptitudes; have low first-term reenlistment rates; and have a shortage of career petty officers as related to requirements.

The table on this page will give you an indication of your chances of getting proficiency pay as a result of the examination you took in November.

This year, the pro-pay test was given in November for all ratings. In the future this will not be true. Men in pay grades E-4 and E-5 will compete annually on the first Tuesday in November, and those in pay

grades E-6 and E-7 on the first Tuesday in May.

The next time E-6 and E-7 personnel may compete, however, is May 1961. To compensate for this, those first class and chief petty officers who are awarded proficiency pay as a result of the November 1959 examination will receive it for 18, rather than 12, months.

Proficiency pay awards will be based on a proficiency pay multiple which includes your *performance factors* and the result of the *service-wide competitive examination*. Selection will be made from those who pass the examination by awarding the money to career men first (in order of their multiple) and then to non-career men in the same manner.

The numbers in each rate, as shown in the table, may be awarded the extra money, provided a sufficient number have passed the exam to fill the quota for their rate.

Besides being assigned to a billet which utilizes your rating skill, BuPers Inst. 1430.12A lists certain other circumstances under which proficiency pay may be awarded or, once awarded, retained. They include the following categories:

- Personnel assigned or transferred to a course of instruction for conversion to one of the critical ratings.

- Personnel assigned or transferred to billets where they are in training for, instructing in, or serving in a special military program such as the Nuclear Power Program; or the BuPers-controlled instructor billets where personnel are screened and selected on a Navy-wide basis.

- Additional duty assignments not materially interfering with performance of your principal duties.

- Temporary or special duty not exceeding 90 days.

- Temporary duty or temporary additional duty while attending courses of instruction.

- Personnel in a transient status.

- Personnel on authorized leave.

- Personnel hospitalized for disease or injury not the result of his own misconduct after the date of the proficiency pay award. These men may continue to draw proficiency pay to which otherwise entitled for the remainder of their eligibility

Table Shows Allocation of Pro-Pay by Ratings

RATE	APPROXIMATE NO. PETTY OFFICERS	NUMBER WHO MAY RECEIVE PRO-PAY	RATE	APPROXIMATE NO. PETTY OFFICERS	NUMBER WHO MAY RECEIVE PRO-PAY
BM	14,500	633	DC	3400	154
*QM	3700	574	*PM	110	36
*SM	2700	553	*ML	175	28
*RD	4700	3413	*SV	100	50
*SO	2800	1738	*CE	675	123
*TM	3200	386	EO	1550	66
GM	8200	384	CM	900	42
*GS	650	340	*BU	1400	350
*FT	4900	2103	*SW	500	58
*NW	400	229	*UT	650	94
MN	650	31	AD	21,200	845
*ET	7000	2908	*AT ³	10,000	2825
*IM	250	39	AO	4800	209
*OM	200	74	*AQ	1400	328
*RM ¹	10,700	3769	*GF	650	102
*CT	4500	869	*AC	3000	402
YN ²	12,700	588	AB	2700	124
PN	4500	207	*AE	6500	1015
*MA	850	119	*AM	10,600	1378
SK	8100	374	PR	1300	60
DK	1900	92	*AG	1500	456
CS	10,800	470	*TD	1300	268
SH	4800	213	AK	2600	116
*JO	350	130	*PH	2150	252
*LI	380	70	*PT	50	29
*DM	450	72	HM	14,300	619
*MU	1000	301	*DT	1800	206
*MM	12,500	2907	SD	7500	312
EN	10,500	510	Total:	271,600	40,893
*MR	1900	431	TARs	10,500	645
*BT	9200	1260	Recruiters	2000	87
*BR	110	61	Grand Totals	284,100	41,625
*EM	10,500	2244			
*IC	2800	1260			
*SF	6600	994			

¹ Includes TE/RM

² Includes TE/YN

³ Includes AL

* Critical rate

period, but in any event, for no longer than 12 months.

(If you are undergoing treatment at a hospital or other medical facility on the effective date of the proficiency pay award, you *are not* eligible to receive proficiency pay until returned to duty. If, however, you are returned to duty before the limiting date specified in the Naval Examining Center Proficiency Rating Letter, you may be awarded proficiency pay on the effective date listed in the letter—but even then, only if you are in all respects still eligible for such award.)

(If you are returned to duty after the limiting date specified in the Proficiency Rating Letter, authority to award proficiency pay must be requested from the Chief of Naval Personnel, Pers B223.)

- NEC 990 series (men in programs such as UDT) personnel who are serving in or instructing in such special skills.

- Members advanced in pay grade as the result of an advancement test given before the pro-pay test, or who are advanced during the period they are receiving pro-pay, may continue to draw the extra money for the normal period.

- Personnel assigned recruiting duty (exclusive of YN, PN, SK, DK and HM filling recruiting support billets) will compete for proficiency pay based on their special qualifications and outstanding performance as recruiters. Those selected will be designated R-1 rather than P-1.

BuPers Inst. 1430.12A also lists the conditions under which proficiency pay may be revoked. Your commanding officer may *revoke your pro-pay* under the following circumstances:

- If you fail to requalify on the next proficiency examination after you acquire proficiency pay. Revocation will be effective one year from the date that such pay was awarded. (The only exception to the one-year period is the 18 months of pro-pay which E-6 and E-7 personnel will get as a result of the last examination.)

- If, in the opinion of the commanding officer, you fail to maintain the required degree of proficiency.

- If you are receiving proficiency pay and are changed to a different rating, unless you are found to be eligible for pro-pay in the new rat-

ing. (Request for determination of eligibility shall be submitted to the Chief of Naval Personnel in each case.)

- If you are receiving proficiency pay and are appointed to commissioned or warrant status.

- If you fail to reenlist on board within 24 hours following discharge or to extend your enlistment. Proficiency pay will be revoked one day before the expiration of active-duty obligated service, or on the date of transfer for separation, whichever is earlier.

- If you are reduced in rating. However, proficiency pay may not in itself be revoked as a punitive measure.

- If you are reassigned to any duty not requiring the skill on which the proficiency pay is based, including permanent assignment to a course of instruction outside the skill, or not considered a special military program such as the Nuclear Power Program, as described above.

- Personnel advanced to pay grade E-8 shall have proficiency pay revoked on the day preceding the effective date of advancement.

- Personnel assigned to recruiting duty (except YN, PN, SK, DK and HM filling recruiting support billets) shall have proficiency pay revoked effective the day preceding the date of transfer to such duty.

- Personnel detached from recruiting duty (except YN, PN, SK, DK and HM filling recruiting support billets) shall have proficiency pay revoked effective the day preceding date of transfer.

Proficiency pay can not be used

All Navy Cartoon Contest L. Murdock, SMSN, USN

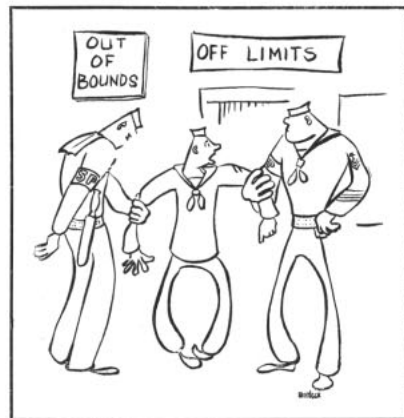

"But I have an out of bounds pass."

as part of your pay when you reenlist. BuPers Inst. 1430.12A says "Any proficiency pay step held when discharged for reenlistment shall be continued, however, reenlistment bonus and payment for unused leave shall be paid according to pay grade held at discharge, excluding pro-pay."

Latest List of Motion Pictures Scheduled for Distribution To Ships and Overseas Bases

The latest list of 16-mm. feature movies available from the Navy Motion Picture Service, Bldg. 311, Naval Base, Brooklyn 1, N. Y., is published here for the convenience of ships and overseas bases. The title of each picture is followed by the program number.

Those in color are designated by (C) and those in wide-screen processes by (WS). Distribution began in October.

The Alligator People (1387)(WS): Melodrama; Beverly Garland, Bruce Bennett.

The Nun's Story (1388) (C): Drama; Audrey Hepburn, Peter Finch.

Born to Be Loved (1389): Drama; Carol Morris, Vera Vague.

Don't Give Up the Ship (1390): Comedy; Jerry Lewis, Dina Merrill.

John Paul Jones (1391) (C) (WS): Drama; Robert Stack, Marisa Pavan.

Face of a Fugitive (1392) (C): Western; Fred MacMurray, Lin McCarthy.

Gideon of Scotland Yard (1393): Melodrama; Jack Hawkins, Dianne Foster.

Ten Days to Tulara (1394): Melodrama; Sterling Hayden, Grace Raynor.

South Pacific (1395) (C) (WS): Musical; Rossano Brazzi, Mitzi Gaynor.

Road Racers (1396): Melodrama; Joel Laurence, Sally Fraser.

The Legend of Tom Dooley (1397): Melodrama; Michael London, Jo Morrow.

The Hangman (1398): Western; Robert Taylor, Tina Louise.

The Big Circus (1399) (C) (WS): Drama; Victor Mature, Red Buttons.

Ten Seconds to Hell (1400): Drama; Jeff Chandler, Jack Palance.

Black Tent (1401) (C): Melodrama; Anthony Steel, Donald Sinden.

The Horse Soldiers (1402) (C): Drama; William Holden, J. Wayne.

If You're Eligible for Recruiting Duty This May Interest You

Are you a petty officer of extremely high caliber?

Have you been on sea duty for some time now, and are you looking forward to some "choice" shore duty?

Will your CO recommend you for recruiting duty?

If you can answer "yes" to all of these questions, then stop sweating. All you have to do is apply and, if qualified, your dreams will be fulfilled.

Your chances of being assigned to recruiting duty now, or in the near future, are very good. At present there is a shortage of qualified personnel desiring recruiting duty.

Although there is an immediate need for recruiters, it must be pointed out that openings are not available in all geographical areas. Recruiters are particularly needed for the 4th, 5th, 8th and 9th Naval Districts. Personnel requesting these districts normally receive orders faster than those requesting other districts.

A Navy recruiter must be a high-caliber individual because he is, in many instances, the Navy's sole representative in a community. As such, he must take part in many community activities. He has the opportunity to use his personal ingenuity and initiative in one of the most challenging and interesting billets in the Navy.

Recruiting is no easy job. Those who are inclined to take it easy and are looking for a "soft" billet should not request recruiting duty. (All persons assigned to recruiting duty are expected to maintain the high standards of the Navy and their conduct must be exemplary at all times.)

If you feel that you meet these standards and are willing to accept the unlimited challenges of recruiting duty, then here are the other qualifications that you must meet before you can apply:

- You must be on Seavey; that is, be eligible for shore duty.
- You must have a GCT score of 50 or above. (A waiver of five points will be considered by the Chief of Naval Personnel, if you are otherwise qualified and highly recommended.)
- You must hold a valid (Navy) motor vehicle operator's license.

- You must have a clear record and show evidence of financial stability and sobriety during current and last previous enlistment. (A clear record is interpreted as one which does not contain official entries indicating conviction by courts-martial or nonjudicial punishment awarded at captain's mast.) It should also be pointed out that your complete record — since you first enlisted — is checked in the Bureau to determine if you are qualified for recruiting duty.

- You must be above average in your individual character traits, sense of humor and forcefulness.

- You must be a career Navyman and provide positive evidence of being completely convinced of the advantages of a Navy career.

- You must have the ability to meet the public and have the personal qualifications for independent duty.

- You must be persuasive in conveying ideas and information, whether in personal contact or in writing.

- You must have a cooperative attitude, as indicated by helping others.

- You must have the ability to converse intelligently on Navy and general subjects.

- You must demonstrate your ability to deal successfully with problems involving ideas and people.

- You must have no speech defects or a marked foreign accent and you must make a presentable appearance.

Your commanding officer should interview and evaluate you on these personal-characteristic requirements before he recommends you for recruiting duty. If you get his unqualified endorsement, you may then apply for recruiting duty when you fill out your Seavey Rotation Data Card.

Your Seavey data card must be prepared and submitted in accordance with par. 4.3 of the *Enlisted Transfer Manual* (NavPers 15909). When you fill out your Seavey data card, be sure that you indicate Recruiting Duty (Code 1-6) as your broad duty preference. In selecting the locality of your choice, do not list two or more cities under the

same main station, as this actually wastes one of your choices. In this respect, you are encouraged to make use of the "anywhere" selection and thus increase your opportunity for selection to recruiting duty. Para. 25.6 of the *Enlisted Transfer Manual* gives a complete listing and code for the cities which have recruiting billets.

Complete instructions on filling out your Rotation Data Card can be found in Chapter III of the *Enlisted Transfer Manual*.

In the event your rotation data card has already been submitted and you have not as yet received orders to shore duty, you may still request recruiting duty. This can be done

Dedication of School

Weymouth, Mass., has named its newest public school after a retired Navyman who earned the Medal of Honor in 1900 as a seaman fighting in China during the Boxer Rebellion.

The dedication of the "William Seach School" now gives the town three public schools named for Weymouth men who have earned the nation's highest award for heroism in combat. Each of the three heroes served in a different branch of the armed forces and earned the medal in a different conflict.

LT William Seach, usn, Ret., is the only one of the group who lived to see the school named in his honor. The other two were Ralph Talbot, who earned the medal as a Marine in World War I and Elden Johnson, a World War II Army man.

The naming of the school for LT Seach is unique, since the by-laws of Weymouth forbid the naming of a public building for a living person. However, through a unanimous vote at the town meeting and the concurrence of the town officials and the school committee, the break with precedent was approved.

LT Seach was an ordinary seaman on board *uss Newark* at the turn of the century, when the wave of anti-foreign violence known as

through a speedletter from your command to the Chief of Naval Personnel (Attn: Pers B21s) requesting that your duty preferences be changed in accordance with para. 3.36 of the *Enlisted Transfer Manual*.

Personnel assigned to recruiting duty are divided into two categories—canvasser-type recruiters and support personnel.

Canvasser-Type Recruiters consist of CPOs and PO1s in all rates on the Seavey, except for a few critical ratings and YN, PN, SK, DK and HM. Personnel selected for duty as canvasser-type recruiters will be ordered by the Chief of Naval Personnel to report to NTC Bainbridge of San Diego for six weeks of temporary duty under instruction at the Recruiter's School. All canvasser-type

recruiters must attend this school even though they have been on recruiting duty before.

Upon successful completion of this school, a recruiter reports to a designated Navy Recruiting Station for temporary duty and further assignment by the officer in charge, since the Recruiting Service is organized on a district basis and each Navy Recruiting Station has sub and branch stations. All canvasser-type recruiters, however, usually receive their ultimate assignments while attending the Recruiter's School. This enables them to make necessary arrangements in connection with dependents and household effects before leaving school.

Support personnel are, as the name implies, those who ordinarily

do not perform duties of the canvasser-type recruiter. They usually do not attend school before being assigned to this duty. Support personnel include YNs and PNs in pay grade E-3 through E-9; SKs and DKs in pay grades E-6 through E-9; and HMs in grades E-5 through E-9.

Support personnel in these ratings are ordered to fill the allowances of Main Recruiting Stations, Class A Substations and Armed Forces Examining Stations.

All personnel—support and canvasser-type recruiters alike—ordered to recruiting duty are normally granted 30 days' delay in reporting.

Waves may also apply for recruiting duty in accordance with instructions contained in Chapter 14 of the *Enlisted Transfer Manual*.

Named for Navyman Recalls Career Packed With Action

the Boxer Rebellion swept China. At Peking the personnel of the foreign legations, along with their families and the legation guards from various nations, were besieged by the Chinese. So, an International Allied Expeditionary Force, composed of over 2000 Navymen and Marines from the warships of eight nations, was organized in June 1900 as the "Pekin Relief Expedition," commanded by British VADM Sir Edward Seymour. The force ran into such heavy fighting between Tientsin and Peking that it didn't get to the capital city until 14 August, and by then it had been made a part of an international army which totalled 18,600 men.

The inscription on the reverse side of the lieutenant's medal reads:

"For conspicuous conduct in the presence of the enemy, in battles of the 13th, 20th, 21st and 22nd of June 1900, while with the Relief Expedition under Vice Admiral Seymour—William Seach, Ordinary Seaman, USS Newark."

The lieutenant was born in London, England, on 23 May 1877. At the age of eight he worked from 0430 until school time on weekdays delivering milk on a pushcart route. On Saturdays and Sundays he worked until noon. When he was 11 years old he left school to work over 12 hours a day in a factory.

After that he spent a year in the school and training ship *Warspite*, an all-sail, line-of-battle ship captured from the French during the Napoleonic Wars. Then, he served two years as Ship's Boy at \$5.00 per month on the full-rigged ship, *Canada*, of Nova Scotia.

In 1898, when President McKinley called for men to serve during the war with Spain, Seach volunteered as an ordinary seaman in the United States Navy. During the war he served in USS *Lancaster*, the battleship *Oregon*, the cruiser *Newark* and several other ships. Besides China, his career took him to the Philippines, Central America and Africa.

During World War I he served in USS *Connecticut*, *McKean* and the troopship, *President Lincoln*. The troopship was sunk by the German submarine, U-90.

Three torpedoes exploded inside *President Lincoln's* hull, sending her to the bottom in 18 minutes. Although 26 members of her crew were lost, all the soldier passengers were saved. The survivors spent over 19 hours drifting about the cold Atlantic.

At one point, the sub surfaced and cruised among the rafts and boats. Seach was beckoned to the U-boat from his raft, and was partly on board when an officer of higher rank—LT Edouard V. M.

Izac—was taken from a nearby boat and made a prisoner of war. Then, Seach was pushed back off the sub and into his raft. Hours later U. S. destroyers rescued the survivors and took them to Brest, France.

[LT Izac, while a prisoner, obtained valuable information about the movements of German submarines. He risked death to escape and carry that information back to U. S. and Allied naval authorities—an action which brought him the Medal of Honor. See ALL HANDS, April 1953, p. 59.]

After his return to the United States LT Seach was hospitalized and later retired for disability incurred in the line of duty. He made his home in Weymouth, where his children and many of his grandchildren attended school.

A bronze plaque in the school named for him bears these words:

WILLIAM SEACH SCHOOL
this tablet erected in honor of
LIEUTENANT WILLIAM SEACH,
U. S. NAVY.
A Citizen of WEYMOUTH
who was awarded the
CONGRESSIONAL MEDAL OF HONOR
for outstanding heroism in CHINA
during
the BOXER REBELLION of 1900.
May the Glorious Deeds of Man
be an
Inspiration to our Children.

Ever Heard of Eleuthera? It's a Good Example of Island Duty

EVER SINCE WE TOLD YOU about living conditions in Chichi Jima (on pages 46-47 of the May 1959 issue), we couldn't help but daydream just a little bit about pulling duty in such a place.

Now, we've found another one—Eleuthera—in the Caribbean. We can only say it sounds good. The duty is up to you. This is what the people on the scene have to say about it:

Innumerable bays and inlets give the narrow 100-mile arc of Eleuthera a rather ragged profile from the air. The Atlantic on the east and the Caribbean on the west have worn away the coral to give the island its placid bays where pleasure boats from the United States and Nassau anchor. The most avid skindivers and fishermen would be unable to exhaust the possibilities these bays offer.

Temperatures range from 72-90 degrees. May through October is usually the warmest time, with high humidity and rain. The tourist from North America is the island's greatest asset.

Eleuthera is a British Crown Colony, with the London-appointed governor residing in Nassau. The island commissioner lives in Governor's Harbour, the 300-year old capital of the island. Other settlements include Hatchett Bay, a settlement where many Navy Facility and Hatchett Bay plantation personnel reside, Alicetown, Gregory Town, Palmetto Point and Rock Sound, a resort settlement.

Clothing—Light summer clothing is advisable for most of the year. Sweaters or light jackets and coats may be comfortable in the evening. Cotton sport shirts and slacks comprise off-base casual wear. Cotton and dacron garments are recommended owing to lack of dry cleaning facilities on the island. Civilian clothing is advisable for off-duty station hours.

Regulation uniform is required for military personnel. The enlisted working uniform is usually dungarees with the tropical uniform or white T-shirts and khaki shorts optional. Officers and chiefs wear wash khaki trousers and short-sleeved shirts. It is strongly advised

David J. Majchrzak, DN, USN



"Here you'll learn to cook food just like mother."

that military personnel have at least six sets of working uniforms and whites before coming to the island. Underwear and socks may be purchased at the ship's store.

Banking and Money—The English system of exchange is used on the island, although merchants readily accept United States currency. It is recommended that checking and saving accounts be maintained in the United States. Naval personnel are paid in U. S. currency.

The table below is listed for information and convenience. The pound fluctuates plus or minus a few pennies from day to day and the table below represents an average.

Sterling into Dollars		
3d	"Thrupence"	4¢
6d	Six pence	7¢
1/—	One shilling	14¢
1/3	One and three	18¢
1/6	One and six	21¢
2/—	Two shillings	28¢
2/6	Half a crown	35¢
5/—	Five shillings	70¢
7/6	Seven & six	\$ 1.07
10/—	Ten shillings	\$ 1.41
15/—	Fifteen shillings	\$ 2.12
17/6	Seventeen and six	\$ 2.47
£1	One pound	\$ 2.82
£5	Five pounds	\$14.10

Naval Facility—The facility was commissioned in October 1958. All buildings are constructed of cement block. The barracks have two decks and are partitioned into cubicles designed for occupancy of four men each. There are double rooms for CPOs. A laundry, a library of approximately 600 volumes and a day-room are included in the EM barracks.

Other buildings on the base include an administration building, a

garage, a ships building, an air-conditioned auditorium and movie hall, galley and mess hall, BOQ and a recreation hall which includes a soda fountain, EM club, barber shop, ship's store, and a commissary.

Dependent Travel—Dependents must travel to the island by commercial carrier under United States jurisdiction, where available. United States domestic airlines maintain schedules to Nassau. Transportation from Nassau to Eleuthera must be made on British Airlines or commercial boat. Failure to make use of United States domestic carriers to Nassau will void all travel claims made on foreign carriers, where domestic transportation was available.

Housing—Government housing for dependents is not available nor is such construction anticipated in the near future. Experience has shown that commercial housing is difficult to obtain, and a waiting period of three to four months can be expected. Housing and approval by the commanding officer must be obtained before dependents' entry is authorized.

Military personnel live in Hatchett Bay and Governor's Harbour. These towns are 15 and eight miles from the facility respectively. Rents run from \$80-150 per month. Most of the homes are furnished; however, personal household items such as linen, dishes and electrical appliances are usually brought. Some homes do not have electricity. Television reception is not worthwhile. Household effects are shipped from Commanding Officer, Army Terminal Unit, Port Canaveral, Fla., by LSMs.

Electricity and water are, in most cases, not included in the house rental. Cost for these utilities is approximately \$5.00 per month for water and \$10.00 to \$60.00 per month for electricity. Propane gas is available. Maids may be hired for \$1.00 to \$2.00 per day.

Purchasing Facilities—Food is sold on the base through commissary store sales with nearly all staple food items available. Local commercial stores carry a limited selection of American-brand items, but these items are generally quite expensive.

Some may be purchased from door-to-door vendors at reasonable prices. Locally grown pineapples and watermelons are delicious.

The ship's store carries toilet articles, limited uniform items, cigarettes, and liquor. Film and some gift items are also carried, and special orders can be placed. Dry cleaning facilities are not available on the island. However, facilities are available in Nassau and personal arrangements may be made with island boat captains to deliver and pick up.

Per Diem Allowance—Personnel with dependents living on the island receive station per diem to augment regular allotments. Enlisted men receive approximately \$2.00 per day, depending on their rating and number of dependents. Officers receive a per diem allowance of approximately \$2.50 per day, depending on their rank and number of dependents. Enlisted men also receive \$1.15 per day commuted rations. (Total of approximately \$3.15 per day.)

Health and Medical Facilities—Limited medical care is administered by a qualified Hospital Corpsman for service personnel and dependents. A small dispensary is maintained on the facility. Emergency medical and surgical first aid facilities are available. The facility has a portable resuscitator-inhalator-aspirator.

Dental care is not available at the facility. Military personnel requiring dental treatment are sent to the United States. A dentist is available three days a week at Governor's Harbour.

The Princess Margaret Hospital in Nassau is the nearest civilian hospital and can handle all types of surgery except brain surgery.

Pregnancy and post-pregnancy present certain problems owing to lack of medical facilities on the island for examination and consultations. Patients must go to Nassau for this care. You should not bring children to the island until they are at least three months old. Expectant mothers who are within three months of delivery are encouraged to return to the United States for delivery.

The following immunizations are required:

Smallpox Initial vaccination with a booster every three years.

Tetanus-Diphtheria. A basic series consisting of three intramuscular in-

jections of 0.5-1.0 cc. The second injection will be given one to two months after the first, and the third 12 months after the first with a booster every 4 years.

Influenza Vaccine. Annual stimulating dose beginning 1 October. All dependents under 15 years old are required to have a Schick negative status or be immunized against diphtheria.

Polio. All personnel under 40 years of age are required to have or begin taking series of three inoculations before transfer to overseas duty.

Typhoid-Paratyphoid. A basic series consisting of three subcutaneous injections of 0.5 cc administered at 7-28-day intervals, booster every three years.

Transportation—Air Force planes make daily flights from Monday through Saturday to the island with mail and personnel. Commercial air-

lines maintain daily schedules to the island from Nassau.

The island receives supplies from Cape Canaveral, Fla., via LSM approximately twice monthly. Commercial boats (passenger and freight) arrive at various ports in Eleuthera.

Commercial traffic on the island is limited to a few cabs and buses. The latter make one trip up and down the island five or six days a week. The schedule is somewhat undependable. Private vehicles are the only practical means of transportation on the island.

Automobile—You may bring your car to the island if you qualify under current regulations (*BuSanda Manual*, Para. 29200.1 a). Automobiles must be driven to Army Terminal Unit, Port Canaveral, Fla. Cars must be adequately insured before a base pass will be issued. Insurance required is \$10,000-\$20,000 liability and \$5,000 prop-

WHAT'S IN A NAME

Fuel Her Up

You may think you've got troubles keeping your finny monster in gas and oil. However, consider your plight if you were to own and operate USS *Ranger* (CVA 61). When the world's largest aircraft carrier said "fill 'er up" at NAS Alameda recently, some three million gallons of jet fuel, avgas and fuel oil were pumped aboard.

Based on current prices, if you gave such an order at a commercial gas station, you'd get a bill for just under \$249,000.

Supplying the fuel in this case was the Naval Supply Depot, Oakland. It was the biggest single delivery of fuel to a combatant ship in the depot's history.

Commercial tug and barge assistance normally hired for an operation of this scope was unavailable because of a strike. That threw the entire job of fueling the 60,000-ton super-carrier on the shoulders of five small Navy Yard oilers, and their 11-man crews.

The five oilers made 13 trips, involving more than 160 hours, hauling the fuel from storage areas at Pt. Molate across the bay to NAS Alameda, *Ranger's* home port.

Repair activity underway aboard *Ranger* would have made fueling operations hazardous during the working day. Thus, most of the transfer of fuel was accomplished during early morning hours.

In all, some 1,750,000 gallons of fuel oil, nearly a quarter of a million gallons of avgas, and about one million gallons of

jet fuel were pumped into *Ranger's* tanks.

The floating service stations delivered the fuel with a smile, but unlike many of their shore-bound counterparts, they didn't provide their customer with trading stamps.

We understand that these stamps are passed out at the rate of one for each 10 cents of the purchase. Sit back and dream. With 2,490,000 trading stamps (or 2075 books) you could get something you've always wanted. Like 231 coffee tables, for instance. Or 207 chrome plated toasters. Or maybe 260 electric razors.

Just 10 such refuelings and there'd be enough stamps to get nearly every crew member an electric razor. Or something.



erty damage. Bahamian out-island licenses must be obtained, and the registration fee is approximately \$10.00. Yearly Bahamian driver licenses must be obtained at a cost of approximately \$1.50.

There are approximately 100 miles of asphalt-paved roads on the island. The highway is rough, but adequate. Construction was planned with small cars in mind and, therefore, the roads are narrow as a general rule. Have the car undercoated and completely serviced before shipment. Servicing facilities are extremely limited and expensive. Service of American cars other than a few

leading makes is practically non-existent.

Gasoline may be purchased on the base for approximately half of the island price. Tires last about 10,000 to 15,000 miles. They must be ordered from the States.

Schools—A private school through the seventh grade is available on a quota basis in Hatchett Bay. Tuition charges are partially paid by the government. A native public school in Governor's Harbour is available from the first through the eighth grades. The academic level is somewhat lower than the U. S. standards. Many families utilize the Cal-

vert System. The cost is borne by the Navy.

Church Services—Church of England, Roman Catholic and Methodist denominations predominate. Roman Catholic Mass is said every Sunday on the facility and in the settlements. A visiting Protestant minister conducts services weekly at the facility.

Recreation—Movies, vintage 1938-1958, are shown nightly in the base auditorium. A recreation hall is outfitted with a beer bar, pin ball machine, skill pool, and shuffleboard. The day room of the barracks has a pool table. Weekly ball games are

It's Time to Get Hot on Your Deep Freeze Applications

It may not be too late for you to volunteer for duty with the Navy Deep Freeze units supporting the 1960-61 U. S. Antarctic Research Program.

The first call for volunteers went out in BuPers Notice 1300, of 18 Sep 1959, which set a November '59 deadline for receipt of applications by the Chief of Naval Personnel. However, since applications from enlisted men in certain ratings are still being accepted, you may yet be able to get in on the program.

Training for the program will begin in early 1960, and will be followed by deployment to the Antarctic in the fall of 1960. Summer support operations will be conducted during the fall of 1960 and in early 1961, while the wintering-over period will last from late February '61 to the fall of '61.

The first call for volunteers sought enlisted men in these ratings for the wintering-over party during calendar year 1961: ET, RM, YN, PN, SK, DK, CS, SH, SN, MR, EM, EN, DC, SF, CE, CM, EO, BU, SW, UT, CN, AB, AM, AT, AG, AD, PR, AC, PH, AE, AK, AN, DT and HM.

It also sought volunteers in these ratings for summer support operations with VX-6: AD, AM, AT and AE with experience in R7Vs, P2V-7s, R4D-8s, HUSs, R3Ys (or other turbo-propeller qualifications), and YN, PN, SK, DK, CS, SH, SN, AB, AG, AK, PR, PH, AN, HM, DT, SD and TN.

To qualify for the program you must:

- Be a volunteer.
- Have at least 28 months of obligated service, or agree to extend.
- Be found physically qualified and temperamentally adapted to withstand rigorous living and working conditions in Antarctica. A standard Form 88 and 89 should be completed on each individual and inserted in his health record. The standards for submarine personnel (as listed in Article 15-29 of the *Manual of the Medical Department*) shall be met, except that minimum visual acuity can be as low as 20/40 in one eye and 20/70 in the other, if both are corrected to 20/20 with glasses. Weight limits are the same as the minimums and maximums prescribed for officers.

A psychiatric interview will be conducted if possible. Candidates with a history or evidence of emotional disorder, chronic or recurrent illness for which they require treatment, and those currently in need of medical care will be disqualified. The physical exam and psychiatric interview will be conducted at a hospital if possible.

- Have a clear record and no history of domestic problems or indebtedness.
- Be recommended by your CO on the basis of performance, technical skill, resourcefulness, versatility and interest.

In submitting applications the

Enlisted Evaluation Report (NavPers 1339) must be used. Item 18 of that form must show whether or not a dislocation allowance has been paid this fiscal year, and it should include a positive recommendation from your CO. Under Item 10, men volunteering for the wintering-over party will include a signed statement: "I volunteer for Deep Freeze 61." Applications are to be forwarded to the Chief of Naval Personnel (Pers B-21212).

Those selected will be ordered to duty as follows:

- Administration and supply people for the wintering-over party will be directed, on permanent change of station orders, to report to Detachment Alfa, Antarctic Support Activities, Davisville, R. I., about 1 Mar 1960. The rest of the men for the wintering-over party will be ordered to report to Detachment Alfa about 1 May 1960 for indoctrination and training.

- Men in Group IX (Aviation) ratings, selected for the wintering-over party and summer support operations, will be directed on permanent change of station orders, to report to (VX-6), NAS Quonset Point, R. I., between 1 January and 1 March 1960.

- Men who winter over will be issued permanent change of station orders for deployment to the Antarctic.

- Men to replace any who are disqualified after training begins may be ordered at any time during the summer and fall of 1960.

played on a new ball diamond, and courts for volleyball and tennis are available. An organized athletic program also includes table tennis, horseshoes, and pool.

Sporting equipment is available from the Recreation Department. Waters of the Caribbean and the Atlantic provide exceptional opportunities for spear fishing, skin diving, and swimming. White coral beaches provide hunting grounds for colorful sea shells, sunning or just plain beach combing. Duck hunting is fairly good, but all firearms must be registered with the Bahamian authorities and kept in the base armory. A radio ham club is in the formative stages.

Pets—Pets may be brought to the island provided they have been examined and found free of contagious diseases within the previous 24 hours by a competent veterinarian. A certificate of such examination indicating shots given and health condition of the pet should be carried along for presentation in Nassau.

Pointers for the Career Man Planning to Use Korean G.I. Bill for Education

The Chief of Naval Personnel has revised the policy in regard to the "conditional" or unconditional nature of discharges as related to eligibility for educational benefits available under the Veterans Readjustment Assistance Act of 1952—commonly referred to as the Korean G. I. Bill.

The act authorizes education and training at government expense equal to one and one-half times your active service during the period 27 Jun 1950 to the date of your first separation after 31 Jan 1955, up to a maximum of 36 months of such education and training.

However, the regulations state that you must commence this education and training within three years following your first "unconditional" discharge or release after 31 Jan 1955. (The term "unconditional" discharge or release was the reason for the many misunderstandings.)

In the past, all persons separated within three months of expiration of enlistment were considered as having been unconditionally discharged. This decision was based on the premise that they were entitled to the full benefits of a completed enlistment. Three years later this would

result in the loss of educational benefits to those discharged within three months of expiration of enlistment for the purpose of immediate reenlistment, while individuals discharged more than three months early for the purpose of immediate reenlistment, having received "conditional" discharges, retained their rights to educational benefits.

In an attempt to correct this situation, the Chief of Naval Personnel revised this policy and established clear cut definitions for discharges of a "conditional" or "unconditional" nature in relation to deadlines under which veterans of the Korean conflict may begin education and training under the Veterans' Readjustment Assistance Act of 1952.

Here's how the Chief of Naval Personnel now defines the nature of discharges under this revised policy:

- "AN UNCONDITIONAL DISCHARGE or release is a discharge or release from active duty which relieves the recipient thereof from any obligation for further continued active service."

- "A CONDITIONAL DISCHARGE or release is a discharge or release from active duty which does not relieve the recipient thereof from any obligation for further continued active service."

Personnel on active duty discharged at any time before the normal date of expiration of their enlistment or the enlistment as voluntarily extended for the express purpose of immediate reenlistment or who cancel voluntary agreements to extend their enlistment earlier than its effective date for the specific purpose of immediate reenlistment are considered NOT to have been eligible for complete separation and the Navy and the Veterans Administration considers this to be a "conditional" discharge.

All other separations, including those which occur before the expiration of obligated service, such as those authorized under early separation programs implementing prescribed strength reductions, are considered "Unconditional" discharges.

Thus, if you served on active duty between the period of 27 Jun 1950 and 31 Jan 1955 and are eligible in all respects, you must begin your education or training within three years after discharge or separation. If you were still on active duty on

A navy doctor from the Naval Medical Research Laboratory, Submarine Base, New London, has been dunked in and under the sea innumerable times lately—and in the process he's proved that his theories concerning pilot escape from a sinking aircraft are far from being all wet.

CDR George F. Bond, NMRL's officer-in-charge, used the submarine USS Sea Cat (SS 399) and a jet aircraft cockpit to conduct a series of underwater tests off Key West, Fla., recent'y.

With the cockpit securely lashed to Sea Cat's afterdeck, and himself equally securely strapped inside the cockpit, Dr. Bond made more than 30 successful escapes from depths of 60 feet, and at speeds up to seven knots (10 feet per second)—the maximum sink rate of two types of Navy carrier planes tested.

Dr. Bond wasn't just out for a swim or a submarine ride. He wanted to

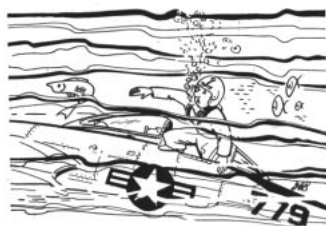

prove a point—that waterflow patterns past the cockpit of a sinking plane will not tend to trap the pilot.

The cockpit's nose faced aft, so that by alternating Sea Cat's bow angle up or down, it was possible to simulate the action of a plane sinking either nose first or tail first. It was found that when the nose sinks first, the pilot is literally swept clear of the aircraft. In the case of a plane sinking tail down, water action forces the canopy open wide enough for the pilot to crawl through.

Dr. Bond feels that the tests demonstrated that a pilot's greatest danger comes not when he hits the water and goes under, but after he clears the cockpit. The concentration now, he thinks, should be placed on teaching carrier pilots what to do after they escape the plane.

A partial cure, the doctor says, would be to train pilots in the buoyant ascent technique taught all submariners. This method of rapid ascent involves exhaling air continuously on the way to the surface, thus equalizing diminishing pressure and avoiding serious and often fatal air embolism.

Among other conclusions drawn from the tests were the need for a free-flooding cockpit, a foolproof canopy lock release and an automatic detaching mechanism for the canopy.

31 Jan 1955, the three-year period begins on the date of your first "unconditional" discharge or release from active duty after that date.

If you were separated on or before 31 Jan 1955 your education and training will terminate on 31 Jan 1963.

If you were separated after 31 Jan 1955, the deadline for finishing your education or training is 31 Jan 1965 or eight years from the date of separation, whichever comes first.

If you are a career man who is planning to apply for the educational and training benefits at the end of your naval career, you must bear in mind that it is definitely to your advantage to request discharge before the expiration of your obligated service for reasons of immediate reenlistment in accordance with the provisions of BuPers Inst. 1133.4A (Subj: Discharge and reenlistment of Regular Navy enlisted personnel within one year of expiration of enlistment date).

It is to your disadvantage to wait until your enlistment is completed before reenlisting, since the three-year period begins on the date of this discharge, at which time there is no obligation for further service even though it is your intention to reenlist. For example, if your enlistment expires on 15 Dec 1959, you should request discharge to be effective no later than 14 Dec 1959 in order to reenlist on board without being penalized by the eligibility requirements.

If you have been discharged since 31 Jan 1955, reenlisted on board your present duty station, and are in doubt as to where you stand, you may submit a request to the Chief of Naval Personnel (Attn: Pers-B222) via your C.O. for clarification of your status relative to the nature of your discharge with respect to educational or training benefits under the Veterans' Readjustment Assistance Act of 1952 in accordance with the provisions of BuPers Inst. 1760.17.

When you have finally been separated from the Navy, and apply to the VA for educational or training benefits, the VA will request a determination from the Chief of Naval Personnel as to the "conditional" or "unconditional" nature of your discharges since 31 Jan 1955. The

All Navy Cartoon Contest
R. S. Dwinell, EN1 (SS), USN



"Well, yes, some people do consider the skipper to be a little old fashioned."

answer given to the VA will be as indicated in the above policy.

Rules on Transfer Of Naval Reservists To Regular Navy

Qualified Reservists in open rates, who began their current tours of active duty before 1 Sep 1958, no longer have to wait until their Reserve enlistments are up to go Regular. Instead, an open-rate Reservist in this category, who is not a TAR, can now enlist in the Regular Navy in his current rate upon completion of his active duty obligation.

As under previous regulations, an active-duty, non-TAR Reservist in the pre-September-58 group can still become a Regular at his current rate (regardless of whether it's an open one) by remaining on active duty until his enlistment or extension of enlistment in the Reserves expires. Then he enlists in the U. S. Navy within 24 hours of his discharge, on

All Navy Cartoon Contest
R. C. Shuman, QMC, USN

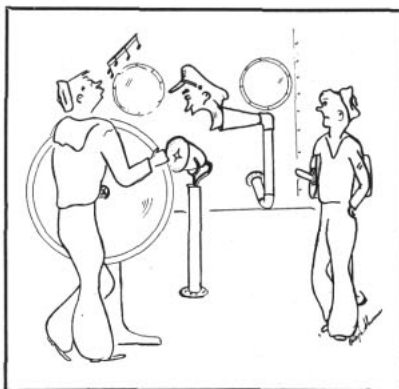

"I said right full rudder!"

board the activity from which he is discharged. If he does not wish to enlist in the Regular Navy, he will still be released from active duty upon completion of his active duty obligation.

Latest information on Regular Navy enlistment by Reservists who began their current tours of active duty before 1 Sep 58 is contained in Enclosure Two, of BuPers Inst. 1130.4F, as amended by Change Two. Under the revised enclosure, a Reservist is considered to be in an open rate if he is one of these categories:

- He is now serving in, or has passed an examination for one of the petty officer open rates listed in Enclosure Four, (Change One), of BuPers Inst. 1130.4F.
- He has qualified in all respects, including passing an examination, for a change in rating to a petty officer open rate.
- He is serving in Pay Grade E-3, and is a designated striker for a petty officer open rate.

In cases where open-rate Reservists have already executed agreements to extend their obligated active duty to coincide with the expiration of their Reserve enlistments, immediate discharge for the purpose of enlisting in the Regular Navy is now authorized. Article C-10306(1) (c) of the *BuPers Manual* (1959) and BuPers Inst. 1130.4F are to be cited as authority for discharge and enlistment on page 14 of the closed-out service records of open-rate Reservists who go Regular.

The regulations on Regular Navy enlistment by pre-September-58 TARs under the cognizance of district commandants remain unchanged by the revision of Enclosure Two.

They may, if qualified, enlist in the Regular Navy, in current rate, at the expiration of their current Reserve enlistment or extension of enlistment, if they do so within 24 hours of discharge on board the activity from which they are discharged.

If not enlisted in the Regular Navy, they will be released from active duty upon completion of their current Reserve enlistment or extension of enlistment, unless they have been on continuous active duty since 1 Jan 1952 and have 15 years or more of active duty as of 1 Jul 1958. In that case, they may either enlist

in the Regular Navy within 24 hours of discharge, or they may reenlist in the Reserves and be retained on board as TARs. Those who decide to reenlist in the Reserves and remain TARs will not be eligible for later enlistment in the Regular Navy.

As to extensions of enlistment in the Naval Reserve, Enclosure Two specifies that active-duty Reservists in the pre-September-58 category, not serving as TARs, may agree to extend their enlistments in accordance with Article C-1407 of the *BuPers Manual*, so as to have enough obligated service to attend schools or be assigned to specific types of duty. Those agreeing to such extensions may only cancel these agreements in accordance with the provisions of Article C-1407. Other agreements to extend will not be granted without prior approval by the Chief of Naval Personnel.

Reservists covered by Enclosure Two may be permitted to extend their obligated active duty to coincide with the expiration of their current enlistments or extensions of enlistment by executing agreements to such extensions on page 10 of their service records. The agreement must be signed by the individual and his commanding officer or his CO's designated representative. Such individuals must be physically qualified for sea duty.

USNR "obligors" (either six- or eight-year obligated duty), not serving as TARs, may be permitted to extend their active duty within the period of their military obligation. Agreements to such extensions as these should be made on page 10 of the service record following the reasons and terms set forth in subparagraphs (2) (a) and (2) (b) of Article C-1407 in the *BuPers Manual*.

Extensions of enlistment or of active duty obligations, which conflict with the provisions of Article C-10318 in the *BuPers Manual* or BuPers Instructions of the 1133.12 series, cannot be granted.

ANSWERS TO QUIZ AWEIGH

1. (b) Full dress uniforms.
2. (c) Tropical white long uniforms.
3. (b) "Pig."
4. (c) Sweep mines.
5. (b) PO2.
6. (b) Staff sergeant.

Quiz Aweigh is on page 45.

HOW DID IT START

Banshee

Nearly 15 years ago the Navy awarded a contract to design, construct, and test the XF2H-1. That plane has since been recorded in naval aviation history as the F2H Banshee jet.

During the years since 1945 the Navy has taken delivery of over 800 Banshees. The F2H has been used in almost every type mission available to a single-seat, carrier-based aircraft.

The F2H-2, similar to the F2H-1, with the tanks added, saw action in Korea as both a fighter plane and as a light attack aircraft.

The F2H-2P, photographic version, was the first Navy jet photo plane ever developed. It was used extensively in the early Fifties.

The F2H-3 and 4 were the latest Banshees developed and are considerably larger than their predecessors. They have an attack radar system incorporated which gives them all-weather capabilities.

This year, 1959, marks the final chapter for one of the Navy's most popular aircraft in recent years. VAW-11, Detachment Papa, recently deployed in WESTPAC aboard

USS *Hornet* (CVS 12), flew the last operational Banshees in the Pacific. Detachment Papa, with 53 men and six officers, used the F2H-4 all-weather Banshee to provide fighter cover for antisubmarine operations.

Detachment Papa now back at NAS North Island, San Diego, Calif., has swapped their F2Hs for larger and higher performance aircraft. For many Navy pilots, only fond memories of the Banshee are left. The planes are outdated and out of service.



Electronic System Will Keep Inventory of Navy Weapons

The Navy has turned to a transistorized electronic data processing system to keep track of the weapons and ammunition it has ashore and afloat around the world.

The new "501" system was devised by the Bureau of Ordnance and developed by private industry. It will become an important logistics aid to the newly established Bureau of Naval Weapons by providing a worldwide daily inventory of all Navy weapons—from the time they start through the production line until they are expended in training exercises or actual conflict.

Latest List of Appointments To Rank of Warrant Officer

Three first class and 26 chief petty officers have been issued temporary appointments to Warrant Officer, W-1.

These appointments are from an eligibility list established by a selection board convened last February.

Regular Navy appointments were broken down into the following desig-

nators: boatswain (7132), three; aviation ordnance technician (7212), four; ordnance control technician (7242), one; aviation maintenance technician (7412), one; machinist (7432), three; electrician (7542), three; communications technician (7642), one; electronics technician (7662), five; ship repair technician (7742), one; ship's clerk (7822), one; supply clerk (7982), four; dental technician (8182), one; photographer (8312), one.

David J. Majchrzak, DN, USN



"I think something's wrong, I'm not sick."

DECORATIONS & CITATIONS

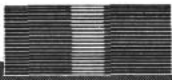

DISTINGUISHED SERVICE MEDAL

"For exceptionally meritorious service to the Government of the United States in a duty of great responsibility . . ."

Gold Star in lieu of Second Award

★ PRIDE, Alfred M., VADM, USN, for exceptionally meritorious service to the government of the United States in a duty of great responsibility as Commander Naval Air Force, U. S. Pacific Fleet, from 30 Jan 1958 to 1 Oct 1959.



LEGION OF MERIT

"For exceptionally meritorious conduct in the performance of outstanding service to the Government of the United States . . ."

★ BROOKS, Daniel P., CDR, USN, for exceptionally meritorious conduct in the performance of outstanding services as commanding officer of *USS Sargo*, SS(N) 583. Under Commander Brooks' excellent leadership and supervision, *Sargo* successfully completed an operation of great value to the government of the United States.

★ FREITAG, Robert F., CDR, USN, for exceptionally meritorious conduct in the performance of outstanding services to the government of the United States from 1949 to 1959, in connection with the Naval and National Guided Missile Programs. Exercising unusual technical ability, Commander Freitag has achieved a national reputation as a leader in the fields of guided missiles, rocketry, ranges and space technology. Possessing an extraordinary ability to conceive and execute large problems, he succeeded in developing and 'selling' the Fleet Ballistic Missile concept and program to the Navy and the Secretary of Defense, and participated in the establishment of this weapon system and the Pacific Missile Range.

★ VAN HEUSEN, Lewis J., MRCM, USN, for exceptionally meritorious conduct in the performance of outstanding services while serving on board *USS Sperry* (AS 12) from September 1957 to 15 Nov 1958. Realizing that formation of ice on submarine snorkel valves has long been known as a factor limiting submarine cold-water operations, Van Heusen, on his own initiative, worked untiringly to perfect an electrically heated water-

proof blanket encasing the snorkel head valve. This device solved the head valve icing problem, but did not prevent the formation of ice in the snorkel mast. Persevering in the attainment of a better remedy, he succeeded in devising a warm salt-water spray which has given excellent results in the most rigorous laboratory tests and in service at sea.

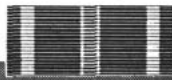

DISTINGUISHED FLYING CROSS

"For heroism or extraordinary achievement in aerial flight . . ."

★ LEWIS, Morton L., LCDR, USN, (posthumously) for extraordinary achievement in aerial flight as pilot and observer of a two-man, Navy Strato-Lab balloon and gondola during a daring and hazardous ascent into the upper stratosphere on 26-27 Jul 1958. Testing aloft, under actual operating conditions, a new-type, sealed environment in the gondola, LCDR Lewis, determined the maximum effectiveness of this entirely new system, voluntarily removing his helmet and oxygen mask, except for take-off and landing, for the duration of the flight at pressure altitudes ranging from 79,500 feet to 82,000 feet and thus risking his life in the event of decompression. Contributing an unofficial world endurance record for sustained flight in the stratosphere of 34 hours and 39 minutes, he also participated in approximately 27 other scientific experiments.

★ ROSS, Malcolm D., CDR, USNR, for extraordinary achievement in aerial flight as Command Pilot of a two-man Navy balloon and gondola during a daring and hazardous ascent into the upper stratosphere on 26-27 Jul 1958. Testing aloft, under actual operating conditions, a new-type, sealed environment in the gondola, which contained a completely artificial atmosphere comparable to that at sea level, Commander Ross removed his helmet and oxygen mask, except for take-off and landing, for the duration of the flight at pressure altitudes ranging from 79,500 feet to 82,000 feet, thereby risking instant death in the event of decompression. In addition to setting a new, unofficial world endurance record for sustained flight into the stratosphere of thirty-four hours and thirty-nine minutes, he successfully completed approximately 27 other scientific experiments.

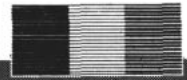

NAVY AND MARINE CORPS MEDAL

"For heroic conduct not involving actual conflict with an enemy . . ."

★ BEHNKE, Albert R. Jr., CAPT, MC, USN, for heroic conduct while serving with Radiological Defense Laboratory, San Francisco Naval Shipyard, from 31 Jan to 2 Feb 1959. Summoned to treat a civilian skin-diver for an acute and potentially fatal case of decompression sickness, Captain Behnke voluntarily entered a pressure chamber and began administering medical aid and comfort to his patient. He remained under continuous pressure for a period of 48 hours until the victim had responded successfully and was removed from the chamber.

★ HARDER, Kenneth E., MN1, USN, for heroism while serving on board the United States Naval Harbor Defense Unit, San Francisco, Calif., on the afternoon of 8 Jun 1959. Hearing cries for help while he was working in a building adjacent to the dock, Harder immediately rushed out onto the pier and observed two people in the water being swept to sea by the swift current. Quickly removing his clothes, he snatched a life ring, plunged into the treacherous waters and swam a distance of approximately 200 yards to the side of the victims, a father and his three-year-old son. Despite the strong current and cold and choppy waters, Harder managed to keep all of them above water until a rescue craft arrived.

★ STANNUS, Robert D., ENS, USN, (posthumously) for heroism in sacrificing his own life in an attempt to save the life of another, while serving as Officer of the Deck on board the *USS Bexar* (APA 237) on 9 Aug 1959. When a shipmate was swept overboard from the *Bexar* into the heavy seas by a huge wave, Ensign Stannus voluntarily entered the hazardous waters in a daring attempt to effect a rescue. After a safety line had been passed to the victim, Ensign Stannus swam toward the ship, but was dragged beneath the surface of the water by a heavy roll of the vessel and was drowned.

★ PETTIGREW, Daniel, SK1, USN, for heroic conduct in the face of great danger to himself and his party while on an assigned mission during June 1959.



George Washington Meets French

Seapower turns the tide -1781

"To Americans," says famed naval historian Alfred Thayer Mahan, "the chief interest of [the Revolutionary] war is found upon the land; but to naval [personnel the chief interest is] upon the sea, for it was essentially a sea war."

The author of "The Influence of Sea Power upon History" looked at the American Revolutionary War from what was then a new viewpoint (see the special supplement of ALL HANDS, April 1952, p. 59), but it is one that is still not widely known.

FRENCH and British route to Chesapeake shown on chart.

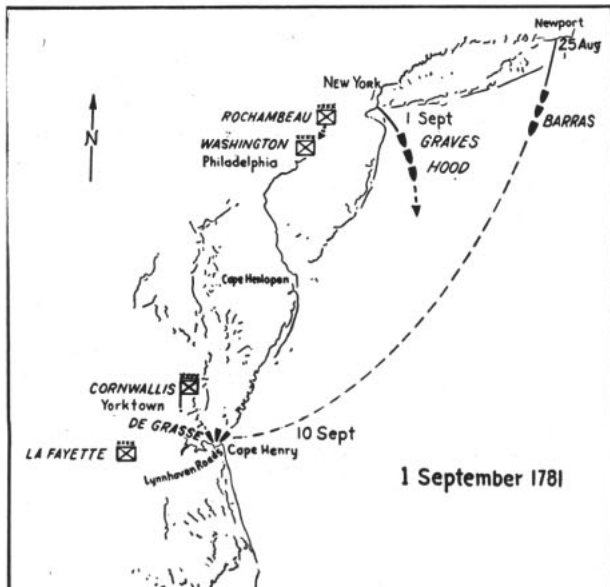

General George Washington himself had emphasized the vital importance of sea power to help win the freedom of the new states. In a memorandum to a special mission sent to France, he had said:

"Next to a loan of money, a constant naval superiority upon these coasts is the object most interesting. This would instantly reduce the enemy to a difficult defensive. . . . This superiority, with an aid in money, would enable us to convert the war into a vigorous offensive. With respect to us it seems to be one of two deciding points."

A graphic account of the decisive naval action of the Revolutionary War, written by Dr. William J. Morgan, head of the Historical Research Section, Naval History Division, Navy Department, was published recently. You don't have to be a student of history to read it and enjoy it.

GENERAL WASHINGTON was at Chester in Pennsylvania on September 5, 1781, moving ahead of his southward-marching Allied army when the great news he had been longing to hear reached him. Admiral Francois Joseph Paul, Comte de Grasse, commanding the French Navy in America, had arrived in Chesapeake Bay six days earlier with a powerful fleet of 28 ships-of-the-line and 3000 troops embarked.

The usually taciturn Washington embraced Rocham-

From "The Pivot Upon Which Everything Turned," by William J. Morgan, appearing in the Spring, 1958 issue of "The Iron Worker," copyright 1958 by Lynchburg Foundry Co., Lynchburg, Va. Reprinted with permission of the copyright owners.



FRENCH FRIEND—Admiral de Grasse brought 28 ships to Chesapeake taking control of the seas from British.

beau and waved his hat furiously in unrestrained joy. At last the naval superiority for which the American commander in chief had pleaded unceasingly, and which he termed "the pivot upon which everything turned," was a reality.

Since the opening months of the Revolution in 1775, while Washington watched the steady flow of supply ships and the King's men-of-war into Boston harbor, the patriotic cause had been hamstrung by Britain's absolute control of the seas. Naval power enabled the British to occupy New York, Philadelphia, Savannah, Charleston, and to strike at will anywhere along the coast. At the same time, Washington's ragged men were obliged to endure long forced marches and one dismal defensive campaign after another to keep the flame of resistance flickering.

The French-American Alliance of 1778 held out the bright prospect of a friendly naval force appearing to challenge the British stranglehold. French squadrons began operating on this side of the Atlantic immediately after the Alliance was formed, but for several disappointing years they were of insufficient strength, and for one reason or another nothing decisive was achieved. Nevertheless, Washington did not swerve from what was to him a fundamental principle—"whatever efforts are made by the Land Armies, the Navy must have the casting vote in the present contest."

He sought every opportunity to urge a true naval superiority.

TOWARD THE LATTER PART of March 1781, Admiral de Grasse and 20 ships-of-the-line sailed from Brest, France, for the West Indian cruising grounds. On May

22 the Generals, Washington and Rochambeau, opened an all-important planning conference at Wethersfield, Connecticut. Whether or not de Grasse intended to come in force to the American theatre was not known to the military leaders.

Washington informed Rochambeau of his preference for a coordinated Allied land and naval attack against New York, seat of British administration in America. General Sir Henry Clinton's defensive capabilities at New York had been reduced by the diversion of troops and ships to the campaign in the Southern states.

Although the Wethersfield conferees set New York as the first objective "in present circumstances," they also agreed that the assault "may be directed against the enemy in some other quarter, as circumstances shall dictate." The "other quarter" to which the door was left open was, of course, the South, where at this time neither Washington nor Rochambeau could foresee that Lord Cornwallis would obligingly place his army on a narrow peninsula with its back to the water.

While preparations pointed at New York went forward along the Hudson after the Wethersfield meeting, the pieces leading to the drama of Yorktown began falling into place. By mid-June of 1781, Rochambeau had definite word, which he immediately passed on to Washington, that the French government had ordered de Grasse to bring the greater part of his fleet to North America.

WHERE AND WHEN the French naval force would appear off the coast was de Grasse's decision to make. However, in spite of Washington's known predilection for New York, Rochambeau helped shape the Admiral's thinking when he wrote: "There are two points at which to act offensively against the enemy: the Chesapeake and New York. The southeast winds and the distress of Virginia will probably cause you to prefer the Chesapeake Bay, and it is there where we think you can render the greatest service; besides, it would take you only two days to come to New York."

The swift and elusive frigate *Concorde*, acting as a courier, reached Newport on August 12 with dispatches making known de Grasse's intention to sail from Cape Haitien on August 3 (actually it was not until the 5th that he got underway) for the Chesapeake. De Grasse stressed that time was of the essence since a commitment to act with the Spanish in the West Indies precluded his remaining in American waters after October 15.

This was it. De Grasse was bringing a naval superiority to the Chesapeake, a "circumstance" provided for at Wethersfield, and which now dictated that the New York campaign be abandoned for the "other quarter." The French-American army broke camp and hastily started southward.

MEANWHILE, unaware of the grand design taking shape against them, what moves were the British making? Cornwallis invaded Virginia from North Carolina in May 1781, and moved about the state while Lafayette and Wayne's small force snapped at his heels. By late August Cornwallis was encamped at Yorktown and fortifying that place as well as Gloucester on the opposite bank of the York River.

Lest we write off the English lord as a complete fool for putting his army in what proved to be an impossible position, let us record several salient facts. In the first place Cornwallis had been ordered by Sir Henry Clinton, his superior in New York, to occupy a naval station site

in the Old Point Comfort-Yorktown area. Further, he was confident that Lafayette did not have the strength to contain him if he desired to move out, and he had no way of divining that Washington and Rochambeau were converging on him from the north. And lastly, but most significantly, he never for one moment entertained the thought that the Royal Navy would be forced to yield and abandon him. In short, there seemed to be nothing in the Yorktown situation which spelled "trap" to Cornwallis.

As soon as reliable intelligence established de Grasse's impending move to the American coast, Admiral Sir George Rodney, senior British naval officer on the West Indian station, detached a 14-ship squadron under Rear Admiral Samuel Hood as a reinforcement for New York. At this juncture, Rodney made a fatal miscalculation in estimating the size of the fleet de Grasse would bring to America. Consequently, he did not allow Hood a sufficient number of ships.

Admiral Hood departed Antigua in the West Indies on August 10, five days after de Grasse had sailed from Haiti. Both fleet's took more or less parallel courses but did not fall in with each other on the northward passage. The coopered bottoms of the British ships made them faster sailers than the French. Hood reached the Capes of the Chesapeake August 25, took a look inside, found nothing amiss, and continued on to New York, where the squadron passed under the command of the senior flag officer, Rear Admiral of the Red Sir Thomas Graves.

THIS THEN WAS THE situation on August 30, 1781, when de Grasse's 28 ships entered Chesapeake Bay and came to anchor in Lynnhaven Roads. Cornwallis was digging in at Yorktown, and the British fleet numbering 19 line-of-battle ships was at New York. Washington and Rochambeau's combined armies had reached Philadelphia, while Lafayette waited in position to contest any attempt by Cornwallis to retreat into North Carolina. A French squadron, comprising eight ships-of-the-line under Admiral de Barras, was at sea after clearing Newport for the Chesapeake on August 25 with heavy siege guns on board.

De Barras' direction made it clear to the British command that the major Allied effort was being aimed against Cornwallis. Admiral Graves' fleet weighed from

Sandy Hook on the first of September hoping to snare de Barras en route and still reach the Chesapeake before de Grasse. The French squadron out of Newport was not found, and the British held their southerly heading without incident to the mouth of the Chesapeake. On Wednesday morning September 5, the scout frigate *Solebay* signaled the presence of a fleet inside the Bay at anchor from Cape Henry to the Middle Ground Shoal. Standing on the quarterdeck of his 98-gun flagship *London*, Admiral Graves had only to scan a long glass rapidly over the forest of tall masts to recognize at once that this was not de Barras, but de Grasse with the main French body. The supreme moment was at hand.

If the Frenchman elected to come out and fight, as most assuredly he would, Graves held the tactical whip hand oft discussed over wardroom pipe and glass but seldom realized. The English ships were in open water bearing down before the wind. On the other hand, de Grasse's lumbering fleet had to gather up crewmen scattered around the harbor on various duties, take in their boats, prepare to get underway, and, when ready, beat out through a narrow channel a few ships at a time.

Graves could fall on the disordered French van in force as it straggled out; that is, "gang-up" on the first ships to clear the Bay. In this manner, de Grasse's superiority in ship numbers and weight of metal would have been nullified, and to use the language of military science, the French fleet might well have been destroyed "in detail," i.e., piece by piece.

A Rodney or a Nelson would not have muffed such a golden opening to land the knockout blow, but fortunate it was for American independence that Thomas Graves was neither. His tactical precepts were those of the Royal Navy's venerable and encrusted "Fighting Instructions," based on the classic concept of two opposing lines of battle with ship against ship slugging it out broadside to broadside in the manner of jousting knights. And this is how Graves would fight de Grasse. From *London* went the Admiral's signal to form the "line of battle ahead," distance between ships one cable length (608 feet in the British Navy).

ABOUT NOON the French fleet began standing out on the ebb tide. By two o'clock, the van and center, 16 ships including the huge 104-gun *Ville de Paris* in which de Grasse flew his flag, were well outside the Bay on an

BRITISH BRASS—Top British Navymen in 1781 sea fight were (left to right) ADM Hood, ADM Graves, ADM Rodney.



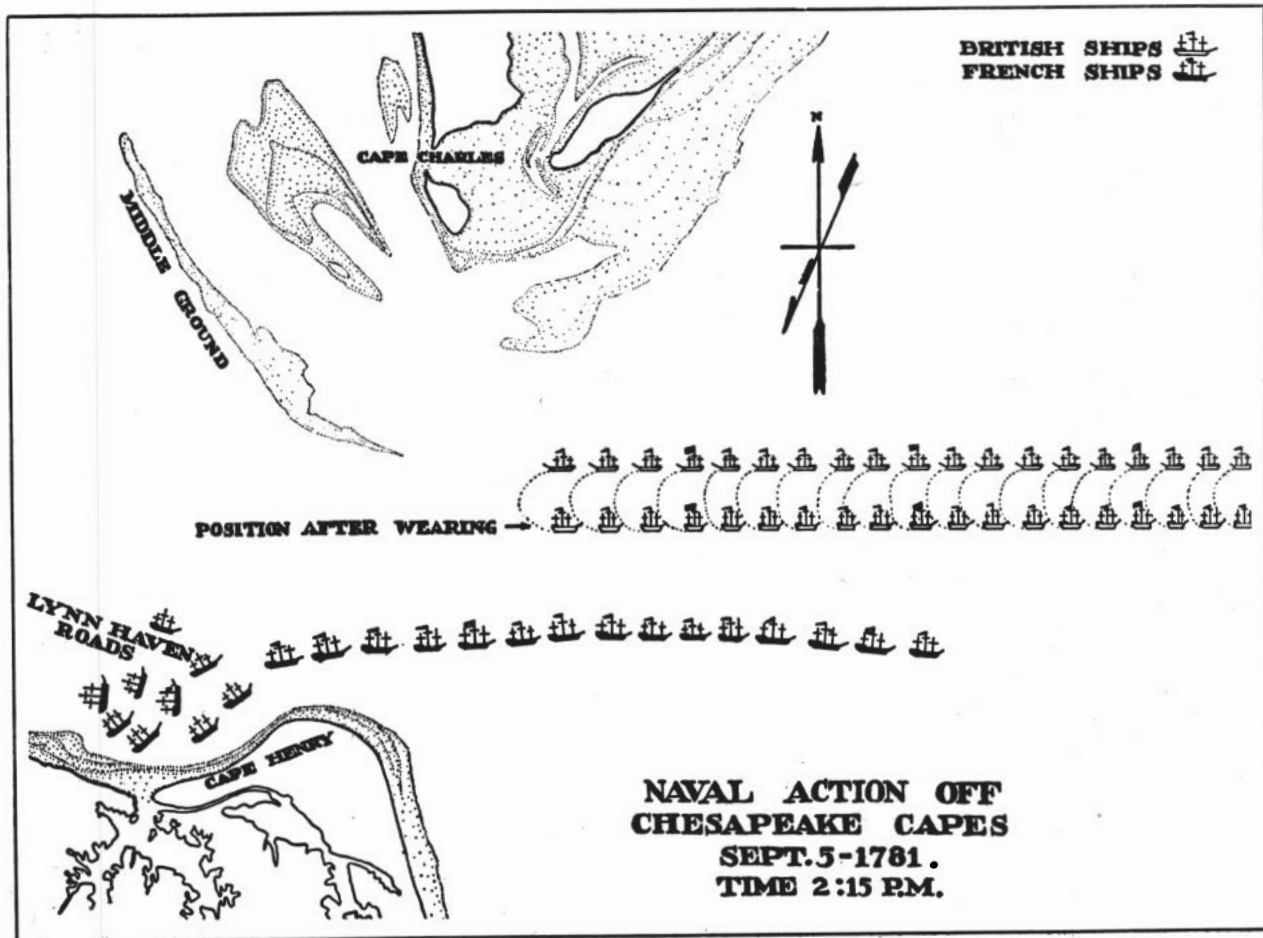

TURNING POINT—Chart shows how Admiral Graves lined up for battle with French ships of Admiral de Grasse.

easterly course. Graves, still holding the weather gage, ordered his ships to wear, thus bringing the English line parallel to the French and on the same heading. De Grasse's lead ships were then opposite the English center, and Graves did not break the signal "bear down and engage the enemy" until the French line had advanced to a position where van opposed van.

The French ships were all out and formed up at four o'clock when the cannonade opened on both sides. Graves hoisted conflicting signals which utterly baffled the English division commanders and captains as to whether it was the Admiral's intention to maintain the strict line ahead or release ships to seek targets of opportunity. Therefore, the action never became general. Only the van ships were closely engaged, the centers partially

at long range, and the rears not at all.

Darkness broke off the fight. Both fleets drifted with wind and water to the south taking stock of damages and casualties. Killed or wounded numbered several hundred on each side. No ships had been taken or sunk, although several were cut up severely, and a British 74, *Terrible*, was in such distress that Graves ordered her to be destroyed by burning.

THE DAY FOLLOWING the battle, the antagonists lay becalmed licking their wounds within sight of each other. For two more days de Grasse and Graves exchanged the weather advantage, yet neither showed any disposition to renew the engagement.

The French and British commanders alike during this

DE GRASSE RETURNS—French cruiser de Grasse brings famous name to Chesapeake at international naval review.



period seem to have suffered mental lapses regarding their primary missions which were, of course, for the one to hem in Cornwallis and for the other to rescue him if need be.

This realization returned to de Grasse first. He crowded on sail and took the wind for the Chesapeake where he arrived on September 11 to find himself happily strengthened by de Barras' squadron.

Graves was shackled by indecision and, much to the disgust of his second in command (Admiral Hood), he delayed some forty-eight hours before following de Grasse. Once it was firmly established that the French had reentered the Chesapeake, a Council of War among the senior British officers considered "the position of the Enemy, the present condition of the British Fleet, the season of the year so near the Equinox, and the impracticability of giving any effectual succour to General Earl Cornwallis in the Chesapeake" and unanimously resolved to return to New York. From the hour of this decision, Cornwallis was lost.

AS A NAVAL ENGAGEMENT, the action of September 5 off the Virginia Capes was a mere brush rather than a head-on clash. *Yet, in its results it has been called, and with good reason, one of the most decisive battles in world history—fought for the prize of a continent.* Command of the sea, albeit local and temporary, passed to the French and American Allies. Neptune smiled on the Americans with a light that was to bring independence.

Washington hastened from Williamsburg, where he had joined Lafayette on September 14, to *Ville de Paris* with warm personal congratulations for de Grasse. During the shipboard visit he extracted an agreement from the Admiral to remain in the Chesapeake until the end of October to prevent their quarry from making an eleventh hour escape.

Cornwallis found it hard to accept the fact that the stout wooden wall at his back was not the heretofore omnipotent Royal Navy and that he had been left irrevocably to his fate. "Nothing," he said dolefully, "but the hope of relief would have induced me to attempt its [Yorktown's] defense." So the land siege with the thundering artillery bombardments, the digging of earthwork "parallels," customary sorties, and gallant storming of redoubts was played out to the inevitable conclusion. But this was anticlimatic, for as the British historian Captain W. M. James states: "the victory in the end was to the holder of the sea line of communications." Lord Cornwallis surrendered over seven thousand men on October 19, 1781.

When the last red-coated British trooper had stacked his arms, and the final drum beats of the melancholy march, "The World Turned Upside Down," had died on the crisp fall air, Washington gratefully wrote de Grasse to thank him "in the name of America, for the glorious event for which she is indebted to you. . . ." The Admiral responded with a masterful understatement: "I consider myself infinitely happy to have been of some service to the United States."

CONTEMPORARY painting shows British fleet attacking French during battle off the Chesapeake Capes in 1781.

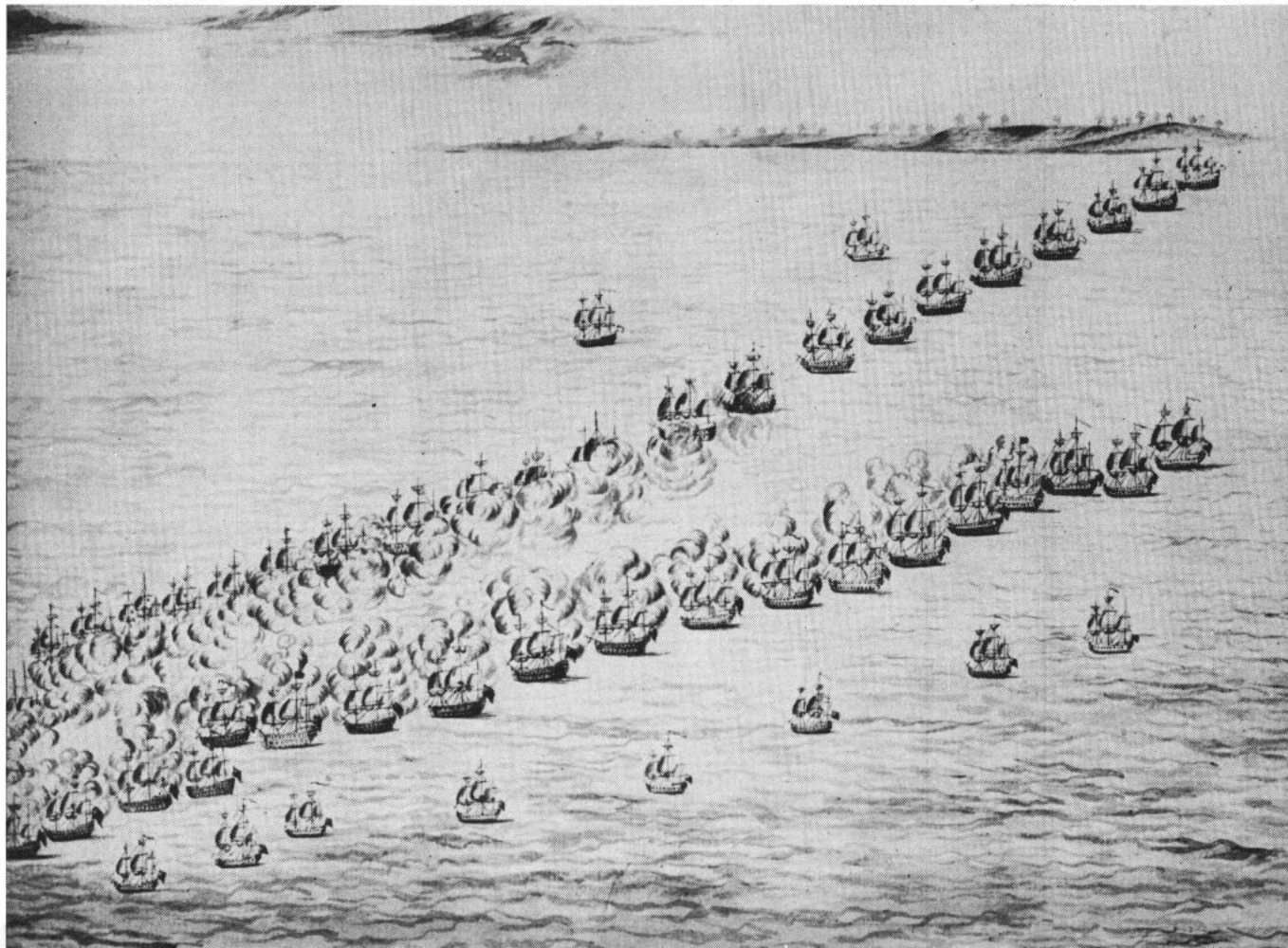

WE'RE ALWAYS EAGER to hear how our fellow journalists are making out. That's why we were willing to give our editor-in-charge-of-not-so-vital-statistics (who, of late, has not been highly popular around the office), a reasonably fair hearing.

After intensive study of the *Directory of Ship and Station Newspapers*, our burbling editor-in-charge-etc. informs us that:

There are now current some 437 Navy newspapers with a circulation of 731,509. The largest of these is "Shipworker," published by the N. Y. Naval Shipyard, with a 15,000 public. The smallest is the "Barrier Sentinel," of the picket ship *uss Hissem* (DER 400), with a press run of 15.

The papers are printed with just about every known method of reproduction with the possible exception of pen and ink. Editors are of every pay grade and rank and from all fields and specialties. This includes writing. However, we are not willing to vouch for this statement.

Future researchers will undoubtedly find important clues as to contemporary Navy thought in the titles of many of the publications. The conservative trend is indicated by the 25 "News," 15 "Newsletters," and 8 "Bulletins" to be found in the *Directory*.

Other types are represented by four "Rockets," three "Jets," three "Missiles," and four "Air Scoops."

The eggheads are adequately represented by *Independence's* "Declaration," by *Sturtevant's* "Fiddler's Green," *Graham County's* "Graham Cracker," and *Gen. W. A. Mann's* "Mann-U-Script."

★ ★ ★

Our miscellaneous-facts-editor has been busy too. He insists upon telling us of new weapons in his arsenal. In this day of the .5 terabuck economy, says he, we can well afford to spend several gigadollars on any number of megapound-thrust rockets. Dig it?

It seems that he has the National Bureau of Standards to thank for this contribution. NBS has threatened to use four new prefixes to designate extremely large and extremely small numbers in the metric system. The prefixes are "tera" meaning one trillion (or a million million); "giga," meaning one billion; "nano," meaning one-billionth; and "pico," meaning one-trillionth.

★ ★ ★

That season has come and gone again. But there has been an upset in the Bean Soup Derby—a shattering of tradition from which the Navy may not sufficiently recover in time for next year's competition.

Third place has been captured by the Army Engineers. This may very well mark the end of Operation Bean Soup, the annual contest to find the best Navy bean soup and bean soup cook in the Navy and, of course, the entire world.

Here are the unhappy details: First place was won—as might be expected—by a Navy commissaryman first class, Edwin H. Busbee, from NAS Norfolk. Second place was won—as might be expected—by PacFlt's *uss Philip* (DDE 498). Third place was won—Oh! Perish the sad day when these words see the light!—by the Army. Our faith in human nature and the validity of publicity campaigns has been shattered.

The All Hands Staff

The United States Navy

Guardian of our Country

The United States Navy is responsible for maintaining control of the sea and is a ready force on watch at home and overseas, capable of strong action to preserve the peace or of instant offensive action to win in war.

It is upon the maintenance of this control that our country's glorious future depends. The United States Navy exists to make it so.

We Serve with Honor

Tradition, valor and victory are the Navy's heritage from the past. To these may be added dedication, discipline and vigilance as the watchwords of the present and future. At home or on distant stations, we serve with pride, confident in the respect of our country, our shipmates, and our families. Our responsibilities sober us; our adversities strengthen us.

Service to God and Country is our special privilege. We serve with honor.

The Future of the Navy

The Navy will always employ new weapons, new techniques and greater power to protect and defend the United States on the sea, under the sea, and in the air.

Now and in the future, control of the sea gives the United States her greatest advantage for the maintenance of peace and for victory in war. Mobility, surprise, dispersal and offensive power are the keystones of the new Navy. The roots of the Navy lie in a strong belief in the future, in continued dedication to our tasks, and in reflection on our heritage from the past. Never have our opportunities and our responsibilities been greater.

ALL HANDS the Bureau of Naval Personnel Information Bulletin, is published monthly by the Bureau of Naval Personnel for the information and interest of the naval service as a whole. Use of funds for printing of this publication is approved by the Director of the Bureau of the Budget 25 June 1958. Opinions expressed are not necessarily those of the Navy Department. Reference to regulations, orders and directives is for information only and does not by publication herein constitute authority for action. All original material may be reprinted as desired if proper credit is given ALL HANDS. Original articles of general interest may be forwarded to the Editor.

DISTRIBUTION: By Section B-3203 of the Bureau of Naval Personnel Manual, the Bureau directs that appropriate steps be taken to insure that all hands have quick and convenient access to this magazine, and indicates that distribution should be effected on the basis of one copy for each 10 officers and enlisted personnel to accomplish the purpose of the magazine.

The Bureau invites requests for additional copies as necessary to comply with the basic directive. This magazine is intended for all hands and commanding officers should take necessary steps to make it available accordingly. The Bureau should be kept informed of changes in the number of copies required.

The Bureau should also be advised if the full number of copies is not received regularly.

Normally copies for Navy activities are distributed only to those on the Standard Navy Distribution List in the expectation that such activities will make further distribution as necessary; where special circumstances warrant sending direct to sub-activities the Bureau should be informed.

Distribution to Marine Corps personnel is effected by the Commandant U. S. Marine Corps. Request from Marine Activities should be addressed to the Commandant.

PERSONAL COPIES: This magazine is for sale by Superintendent of Documents, U. S. Government Printing Office, Washington 25, D. C. The rate for ALL HANDS is 25 cents per copy; subscription price \$2.50 a year, domestic (including FPO and APO addresses for overseas mail); \$3.50 foreign. Remittances should be made to the Superintendent of Documents. Subscriptions are accepted for one year only.

• AT RIGHT: LADY KILLER — One of the best photos ever taken of a hurricane was snapped on radarscope by Navy photographer, B. J. Dalma, PH2. Dark circular area near center is Gracie's eye.



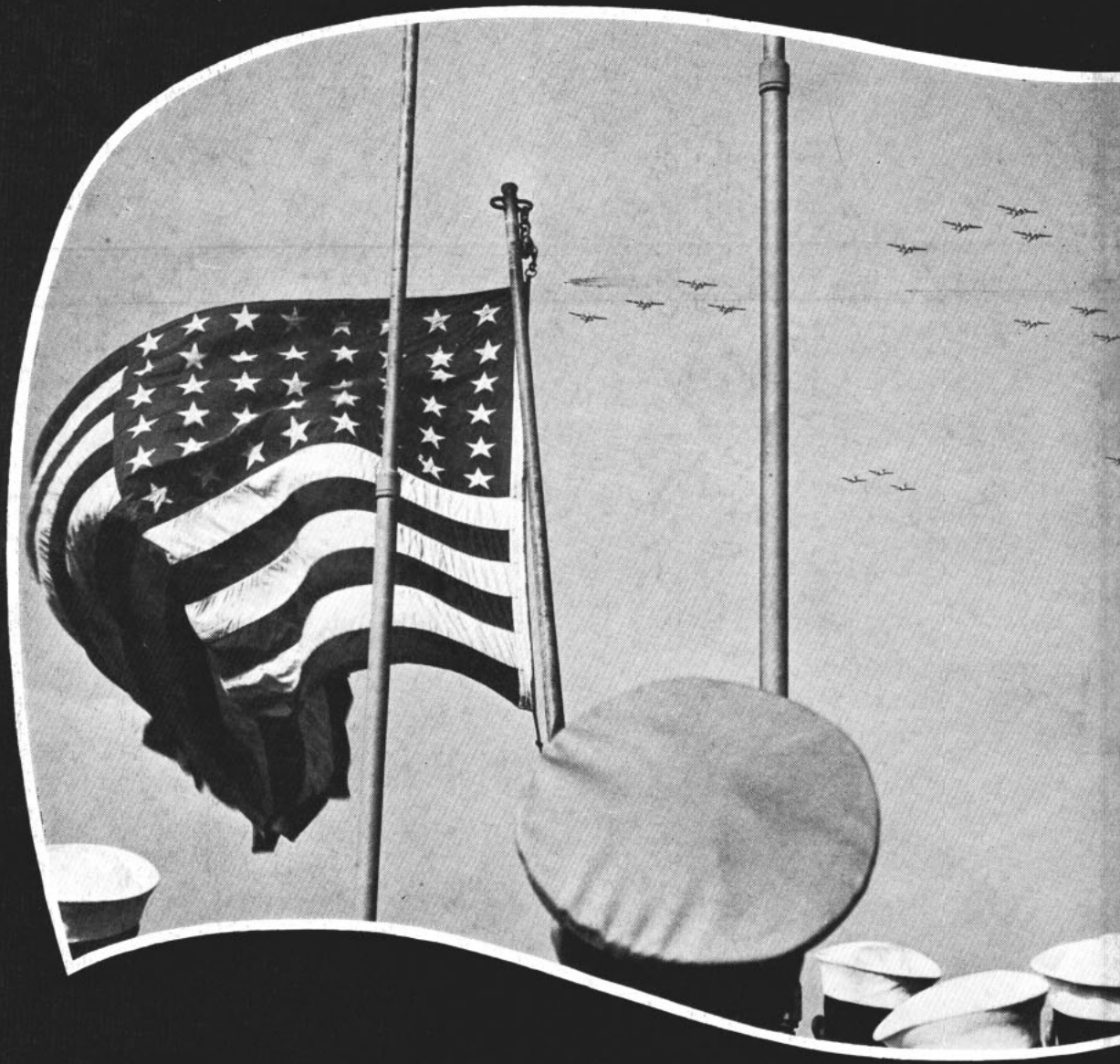

TEAMWORK