

# **PAINT and COLOR MANUAL**



**CG-263**

**REVISED EDITION, 1965**

**U. S. COAST GUARD**

**TREASURY DEPARTMENT**



### COAST GUARD SEAL

The U. S. Coast Guard Seal as shown on this cover sheet is that which the President adopted by Executive Order 10707 of 6 May 1957.

Reproduction of the official seal of the United States Coast Guard is authorized for use on decalcomanias, letterhead stationery, covers of manuals and booklets and otherwise as approved by the Commandant. Reproduction for the above purposes is authorized in the five color combinations or in any two contrasting color combinations as appropriate.

At present all the colors for the seal are described in fabric cable numbers. Federal Standard Color Numbers will be specified as obtainable. Cable number colors are described as follows:

<i>Description</i>	<i>Cable No.</i>	<i>Use</i>
White -----	65005	Stripes, disc, border
Scarlet -----	65006	Red Stripes, motto
Ultramarine ---	65010	Blue letters, chief of shield
Grotto Blue ---	70022	Blue background
Gold -----	-----	Anchors, border



### COAST GUARD EMBLEM

Coast Guard General Order No. 7 of 3 April 1957 prescribes the emblem of the Coast Guard which replaced the emblem adopted in 1927.

The emblem in full color is as shown on the opposite side of this cover page.

The emblem, in the color combinations illustrated above, is authorized for use on the

Coast Guard Ensign and on official flags and pennants in accordance with specifications for each particular flag or pennant. Reproduction of the emblem in full color or two color combinations of blue and white or black and white is authorized for use on decalcomanias, printed recruiting material, or as approved by the Commandant.

# GENERAL CONTENTS

## CHAPTER 1 — GENERAL INFORMATION

General information concerning the purpose of painting, composition and storage of paint materials, preparation of surfaces for painting, and instructions for proper application of paint materials.

## CHAPTER 2 — COATING SYSTEMS

Coating systems (complete paint films from substrate to topcoat) are prescribed for practically all types of surfaces and exposure conditions found in the Coast Guard.

## CHAPTER 3 — COLOR PRACTICE

Color specifications, marking and safety color codes are described and illustrated for shore establishments, vehicles, vessels, aircraft and miscellaneous items.

## CHAPTER 4 — MATERIALS

Information on individual materials concerning their use, instructions for application and means of procurement.

## GLOSSARY

## GENERAL INDEX

For quick and convenient location of the contents of this Manual, the Index should be freely consulted for references and cross-references.

### HOW TO USE THIS MANUAL

- (A) Chapter 1 should be read by all supervisory personnel and used as a reference for problems concerning surface preparation and paint application.
- (B) Selection of color is made by reference to Chapter 3, referring to Section 3-1 and to Section covering unit or equipment concerned.
- (C) Selection of coating systems (types of materials) for different items is next made by reference to pertinent Sections of Chapter 2.
- (D) Selection of individual paint items is accomplished by reference to Chapter 4 where stock numbers are given for colors and types of materials. Sections 1-11-3 and 1-11-7 contain information to assist in arriving at quantities of each item to be ordered.

REVISED EDITION, 1965





TREASURY DEPARTMENT  
UNITED STATES COAST GUARD

Address reply to:  
COMMANDANT  
U.S. COAST GUARD  
WASHINGTON, D.C. 20226

1 October 1965

LETTER OF PROMULGATION

CG-263

1. Purpose. This letter promulgates a revised edition of the Paint and Color Manual, CG-263. The Manual incorporates the latest essential information on paint technology and contains the basic Coast Guard instructions on color, paint materials, and painting methods.
2. Directives Affected. The Paint and Color Manual, CG-263 (1952 edition) is hereby canceled. Commandant's Instruction No. 10360.1 and its Supplement have been incorporated in the Manual and are also canceled.
3. Applicability. The Paint and Color Manual is issued for guidance of Coast Guard personnel concerned with the use of color and paints. The scientific use of color to reduce accidents and to improve working and living environments is a prime consideration of the text. The Manual prescribes the best available materials and coating systems for ships, structures, buoys, and aircraft. A substantial reduction in the total costs to paint Coast Guard Units should result from use of more durable materials, standardization of colors and materials, and stocking a limited variety of materials.
4. Action. This Manual is effective upon receipt, but painting solely for the purpose of changing to standard color schemes shall be accomplished in accordance with the existing need for repainting, present schedules for repainting, and the availability of regularly allotted funds for the purpose.
5. Amendments. Changes to this Manual will be made by consecutively numbered amendments.

  
E. J. ROLAND

Admiral, U. S. Coast Guard  
Commandant

Dist: (SDL No. 80)

A: a, b, c, d, e, w(3); f, h, m, n, v(2); remainder (1)  
B: f(10); g(8); c(7); j(5); e, i, n(4); d, h, k, (3); b, m, p, q(1)  
C: a(3); d, g(2); b, e, f, h, i, j, l, q, r, s, u, v, w, x(1)  
D: v(2); a, b, d, e, f, s, w(1)  
E: None  
F: None  
C: o (Houston only) (2); (Los Angeles-Long Beach) (1)  
D: m (No. 1) only (1)



*Keep Freedom in Your Future With U.S. Savings Bonds*





DEPARTMENT OF TRANSPORTATION  
UNITED STATES COAST GUARD  
PAINT AND COLOR MANUAL  
CG-263

Address reply to:  
COMMANDANT (ETD)  
U.S. COAST GUARD  
WASHINGTON, D.C.  
20591

AMENDMENT NO. 1

24 JUL 1968

1. Amendment 1 consists of pen and ink corrections, replacement pages, and additional pages in order to bring the Paint and Color Manual up to date. A number of new illustrations reflecting the implementation of the visual identification program will be issued as Amendment 2.

a. Make the following pen and ink corrections:

- X SECTION 1-3-17 First paragraph, add: "The heavy body mastic, "Insulmastic," is also hazardous during application. The spray gun should be grounded to guard against explosion of flammable vapors."
- X SECTION 1-11-7 Delete last paragraph. Add: "Defective paints should be reported as instructed in 1-3-15."
- X SECTION 2-2-2(M) Page 11, last sentence of 2nd paragraph, Add: "or epoxy conforming to MIL-C-23236, Class 1."
- X SECTION 2-3-2(A) Page 18, 3rd paragraph, Add to first sentence: "Unless otherwise authorized by the Commandant".....
- X SECTION 2-3-2(D) Page 18, step (d), Add the words, "or Vinyl Antifouling Paint, 2 coats."
- X SECTION 2-3-2(E) Add to (b), "For areas of high industrial pollution, topcoat with either vinyl or epoxy."
- X SECTION 2-3-6 Page 23 first sentence, after the words "Deck and Floor Enamel," add "or Epoxy Enamel where authorized." Second sentence, after "beach sand" add "or 60 mesh garnet"
- X SECTION 2-3-8 Page 24 FUEL OIL TANKS, Add to second sentence: "or apply other approved epoxy coating system conforming to MIL-C-23236, Class 1. Roughen the surface before application."
- SECTION 2-3-10 Page 24 CHAIN LOCKER, Delete and substitute the following:
  - (A) Apply to clean bare steel 1 full coat of zinc silicate conforming to MIL-C-23236, Class 3.

Note: For touch up, always use the same generic type but not necessarily the same brand name. For existing systems of either coal tar epoxy or asphalt varnish repair with similar coating.
- SECTION 2-6-1 Page 35, Third line, Delete "painting" insert "coating systems". Fourth line, Delete, "Bulletin", insert, painting and marking drawings and the related Aviation ~~and~~ Technical Note.

- SECTION 3-13-1(A) Page 91, 2nd paragraph, Add the following: "Details for the new visual identification markings are shown in the detail drawing for each individual class vessel."
- SECTION 3-13-1(A) Page 91, under column, "Class of Vessel". Delete "WAG"; Substitute "WHEC" for "WAVP", "WPG"; substitute "WMEC" for "WPC, WSC, WAT, WATF, WATA".
- SECTION 3-13-1(E) Page 93, After the words, "NO. 24 Spar" ADD: "unless otherwise authorized by the Commandant."
- SECTION 3-13-1(H) Page 93, ADD: "Do not paint the surfaces of winches and capstan drums that contact the line. If such surfaces are steel they may be coated with a light preservative."
- SECTION 3-13-1(I) Last sentence of 3rd paragraph, ADD: "Unless otherwise specified in the detailed plan."
- SECTION 3-13-2(B) Pages 113, 114; Principles No. 8 and No. 9 ADD: Heads, showers, washrooms (Alternate to Principle 5).
- SECTION 3-13-2(C) Page 114, Delete "the red color of Quick Drying Red Lead Primer". Insert, "a close match to #26, Tile Red."
- SECTION 3-14 Page 121, Add the following to 1st paragraph: "VISUAL IDENTIFICATION MARKINGS shall be in accordance with the detailed plan for the specific class vessel."
- SECTION 3-14-1(B) Page 121, Second sentence, delete the words, "No. 32 Blue Gray if steel and ~~if~~ if of wood, plastic or canvas".
- SECTION 3-14-1(C) Page 122, Delete the words, "44 ft. cargo boats and steel utility boats which shall have No. 32 Blue Gray decks."
- SECTION 3-14-1(D) Page 122, Lines, 13 and 14, delete in entirety "40 ft. Utility Boats shall have No. 32 Blue Gray cockpit decks."
- SECTION 3-16 First paragraph, delete, "American Standards Association," insert, "USA Standards Institute"
- SECTION 3-16-2 Second paragraph, after the word "boxes", insert, "transmitting antennae hardware"
- SECTION 3-16-5 Second paragraph, first sentence, after the word, "mechanisms", insert the words, "receiving antennae hardware."
- SECTION 3-21 Page 165, Helmet Illustration, delete, "SECURITY POLICE"
- SECTION 3-21-4(K) Page 166, Delete (c) in entirety. Paragraph (d), delete "just above the words, SECURITY POLICE."
- SECTION 3-23-1 Second Line, delete "all", insert "most"



SECTION 3-24

Page 177, COLOR SPECIFICATIONS, Add the following new colors at the bottom of the list:

"40 RED (Visual Identification) \_\_\_\_\_"  
"41 BLUE (Visual Identification) \_\_\_\_\_"

SECTION 4-8-3

Page 42, Left hand column, Under ORDERING INFORMATION, delete, "Pittsburgh Chemical Company, Protective Coatings Division," insert: "USS Chemicals Div., United States Steel, Pittsburgh, Pa. 15230."

SECTION 4-8-4

Page 42, Right hand column, GENERAL APPLICATION INSTRUCTIONS, 3rd paragraph, Following the last sentence, Add: "The spray gun should be grounded to guard against explosion of flammable vapors by static electricity."

Page 43, Left hand column, Under ORDERING INFORMATION, Delete "Pittsburgh Chemical Company, Protective Coatings Division" Insert: "USS Chemicals Div., United States Steel, Pittsburgh, Pa. 15230."

SECTION 4-8-5

Page 43, Right hand column, GENERAL APPLICATION INSTRUCTIONS, 1st paragraph, after 4th sentence insert, "The mixture in the paint pot must also be agitated during application to prevent settling."

- b. Enclosure (1) to this amendment contains replacement pages in lieu of the former practice of "cut-outs" pasted in place by the user. Remove the old page and insert the new page. EXCEPTION: If a new page number is followed by a letter, i.e., 174a, retain page 174.



D. B. HENDERSON  
Chief, Office of Engineering

Encl: (1) Replacement pages

Dist: (SDL No. 87)

A: a, b, c, d, e, w(3); f, h, m, n, v(2); remainder (1)  
B: f(10); g(8); c(7); j(5); e, i, n(50); d, h, k(3); b, m, p, q(1)  
C: a(3); d, g(2); b, e, f, h, i, j, l, q, r, s, u, v, w, x(1)  
D: v(2); a, b, d, e, f, s, w(1)  
E: None  
F: None  
C: o (Houston only) (2); (Los Angeles-Long Beach) (1)  
D: m (No. 1) only (1)











# CHAPTER 1, GENERAL INFORMATION

## TABLE OF CONTENTS

Section	Title
1-1,	INTRODUCTION
1-2,	THE PURPOSE OF PAINTING
1-2-1,	PROTECTION
1-2-2,	DECORATION
1-2-3,	FUNCTIONAL USES
1-2-4,	THE NEED FOR SAFETY
1-3,	THE COMPOSITION OF PAINT
1-3-1,	WHITE PIGMENTS
1-3-2,	COLOR PIGMENTS
1-3-3,	EXTENDER PIGMENTS
1-3-4,	SPECIAL PURPOSE PIGMENTS
1-3-5,	OIL VEHICLES
1-3-6,	OLEORESINOUS VEHICLES
1-3-7,	ALKYD VEHICLES
1-3-8,	PHENOLIC RESIN VEHICLES
1-3-9,	VINYL RESIN VEHICLES
1-3-10,	CHLORINATED RUBBER VEHICLES
1-3-11,	SILICONE VEHICLES
1-3-12,	EMULSION VEHICLES
1-3-13,	EPOXY VEHICLES
1-3-14,	SOLVENTS AND THINNERS
1-3-15,	JOB-MIXED PAINTS PROHIBITED
1-3-16,	THE MANUFACTURE OF PAINT
1-3-17,	HAZARDOUS PAINT MATERIALS
1-4,	STORAGE OF PAINT MATERIALS AND RELATED ITEMS
1-4-1,	GENERAL
1-4-2,	FIRE AND HEALTH HAZARDS IN PAINT STORAGE AND MIXING
1-4-3,	PAINT STORAGE AT SHORE STATIONS
1-4-4,	SHIPBOARD STORAGE OF PAINTS
1-5,	SURFACE PREPARATION
1-5-1,	PREPARATION OF METALLIC SURFACES (EXCEPT ALUMINUM AND GALVANIZED STEEL)
1-5-2,	PREPARATION OF ALUMINUM SURFACES
1-5-3,	PREPARATION OF GALVANIZED STEEL SURFACES
1-5-4,	PREPARATION OF WOOD SURFACES
1-5-5,	PREPARATION OF MASONRY SURFACES
1-5-6,	CLEANING PAINTED SURFACES
1-5-7,	ABRASIVE PAPER GRADING
1-5-8,	SAFETY PRECAUTIONS IN ABRASIVE CLEANING
1-6,	PAINT MIXING

Section	Title
1-7,	<b>BRUSH PAINTING</b>
1-7-1,	BRUSH CONSTRUCTION
1-7-2,	TYPES OF BRUSHES
1-7-3,	BREAKING IN A NEW BRUSH
1-7-4,	BRUSHING TECHNIQUE
1-7-5,	CARE OF BRUSHES AFTER USE
1-7-6,	STRIPING
1-7-7,	SKIN IRRITATIONS DUE TO PAINTING
1-8,	<b>ROLLER COATING</b>
1-8-1,	ROLLER CONSTRUCTION
1-8-2,	TYPES OF ROLLERS
1-8-3,	DIP TYPE PAINT PANS
1-8-4,	PAINT APPLICATION AND CARE OF ROLLERS
1-9,	<b>SPRAY PAINTING</b>
1-9-1,	TYPES OF SPRAY EQUIPMENT
1-9-2,	PARTS OF CONVENTIONAL SPRAY SYSTEMS
1-9-3,	THE CONVENTIONAL PAINT SPRAY GUN
1-9-4,	OPERATION OF SPRAY EQUIPMENT
1-9-5,	CARE OF SPRAY EQUIPMENT AFTER USE
1-9-6,	SAFETY PRECAUTIONS FOR SPRAY PAINTING — GENERAL
1-9-7,	SPECIAL PRECAUTIONS FOR INTERIOR SPRAY PAINTING
1-9-8,	FIRE AND EXPLOSION DATA ON ORGANIC SOLVENTS AND DILUENTS PERTAINING TO ORGANIC COATINGS
1-10,	<b>PAINT FAILURES</b>
1-10-1,	CHALKING
1-10-2,	ALLIGATORING
1-10-3,	FLAKING, CRACKING AND SCALING
1-10-4,	BLISTERING
1-10-5,	GAS DISCOLORATION
1-10-6,	MILDEW
1-10-7,	SUCTION SPOTTING
1-10-8,	DIRT COLLECTION
1-10-9,	PEELING
1-11,	<b>SUPERVISION OF PAINTING</b>
1-11-1,	FREQUENCY OF PAINTING
1-11-2,	WEATHER CONDITIONS FOR PAINTING
1-11-3,	ORDERING PAINTS
1-11-4,	ORGANIZING FOR THE JOB
1-11-5,	SCAFFOLDING
1-11-6,	CONTROL OF FILM THICKNESS
1-11-7,	PAINT RECORDS
1-11-8,	CONTRACT PAINTING



## SECTION 1-1, INTRODUCTION

Chapter 1 of the Manual is informational in character and is designed to acquaint personnel and broaden their knowledge of the many different types of protective coatings, composition and general properties; also how to prepare the surface properly and the necessary techniques for proper application. A brief resume' of new materials still in the testing stage is included. These have shown potential for future use.

According to reliable sources, the Federal Government will purchase upwards of \$50 million worth of 2300 organic coatings and related items during the current year. Every attempt will be made to insure that these products reflect the best quality that industry can produce at a reasonable cost. Maximum service will be achieved if the correct coating is selected and the surface properly prepared. The Coast Guard expects to use \$1 million worth

of organic coatings during the current annual year. The oil/pigment type of paint has rapidly been replaced by more complex coatings which utilize synthetic resins unknown to the consumer a few years ago. These coatings have come to the fore through constant research by the raw material manufacturer in cooperation with the paint manufacturer and Government laboratories. In order to take advantage of the newer coatings, proprietary purchasing has been authorized to a limited extent. Federal and Military specifications covering these items are being developed.

From a supply standpoint, procedures have been changed to insure the receipt of freshly manufactured paints. Paints are now being shipped direct from the manufacturer to the supply centers or depots, and in some instances, direct to the bases.



## SECTION 1-2

### THE PURPOSE OF PAINTING

Painting is an expensive procedure. Not only are paints, paint brushes and other paint materials expensive, but the many man-hours consumed each year in painting Coast Guard vessels and stations could well be used for other maintenance work. In order to employ paint materials and painting man-hours effectively and economically, the fundamental purposes of painting must be borne in mind. The importance of each of these purposes depends, of course, on the particular surface which is to be painted. Following is a brief discussion of each of these fundamental purposes of painting.

#### 1-2-1, PROTECTION

Resistance to moisture from rain, snow, ice, salt spray and condensation constitutes perhaps the greatest single protective characteristic requirement of paint. All things made of metal corrode. Moisture causes wood to swell, warp and rot. Interior wall finishes of buildings are ruined by soiling, age or neglect. Paint films must, therefore, be as impervious to moisture as possible in order to provide a protective water resistant film over the surface to which applied. Paint can also act as a protective film against attack by acids, alkalies, or marine organisms.

#### 1-2-2, DECORATION

The word "paint" comes from Sanskrit, the oldest known written language, and means "to adorn." Painted color as a decorative medium, long recognized as an art, has now moved into the realm of science. Tests prove that, correct-

ly used, painted color on interior surfaces has a soothing effect on the nervous system, while uniform brightness in the field of view will aid seeing and reduce fatigue. A compartment or room painted in pastel tints is easy to live in, but a room painted a brilliant red or orange would offer far too much stimulation. It can be readily seen that the selection of color involves more than just the decorative function.

#### 1-2-3, FUNCTIONAL USES

Painting is used as a sanitary measure. A smooth, washable, painted surface, which can be cleaned easily, helps produce a clean and healthful atmosphere. Therefore, a painted compartment is a more healthful place to live in than one that is unfinished and unpainted.

Another purpose of paint is to reflect light. Used in the interior of a ship, light-colored paints reflect and distribute both natural and artificial light better, and thus help secure maximum efficiency from the ship's lighting system. Correct illumination helps you do your job better and easier.

Still another function of colored paint is the identification of objects. Red is used to identify fire-fighting equipment. Yellow means caution. Green means safety. Colors are used to identify compressed gas cylinders, highway traffic lanes, signs of all types and for many other applications. One of the most important uses of color as an identifying medium in the Coast Guard is in Aids to Navigation. Without buoy colors, the effectiveness of our buoy system would be reduced.

### 1-2-4, THE NEED FOR SAFETY

There are many hazards involved in surface preparation and painting. These will be discussed, together with precautionary measures, in applicable Sections and Articles of this Manual. For a complete list and review of hazards and safety practices, consult Article 3-16-1.

Over two-thirds of injuries in surface preparation and painting are due to falls. Much equipment is used, such as ladders, scaffolding, platforms, rolling towers and stages, boat-swains' chairs and the like, and there is much moving about at hazardous elevations above ground or water. Protection here demands proper and safe working equipment, careful supervision, intelligent safety habits, and safeguards afforded by strong supports, ropes and cables, side railings, barricades, plus lifelines, safety belts and life jackets.

Further injuries are often caused by falling objects, and here safety helmets are mandatory. If underfoot surfaces are slick, proper shoes must be worn.

The paint crew is frequently expected to work in or about machinery and tanks. All such devices should be fully guarded.

Fire is a constant danger. Protection here requires safe practices in material handling, adequate ventilation, quick access to extinguishers, the absolute avoidance of flames, sparks or excessive heat in the area or space being painted.

There may be air contamination due to fumes and smoke. Face masks, respirators, air-fed masks and hoods may be imperative.

There may be chemical poisoning caused by liquids or fumes touching the eyes or skin or being ingested through the mouth. Hands must be kept cleaned and coated with a protective cream. The eyes and the body must be protected by suitable clothing, gloves, masks, hoods, goggles.

Skin irritations and allergies will likewise be minimized by keeping the body covered.

Also, supervision should check on worker attitudes and personality traits. Medical examinations and adequate safety training are desirable. Here is a suggested safety check list.

- Are ladders, scaffolding and staging in good condition?
- Are all ropes and cables in good shape?
- Is there adequate ventilation if painting is done in confined spaces?
- Is the area or interior to be painted set apart by barricades?
- Are NO FIRE and NO SMOKING signs in clear view?
- Are fire extinguishers within handy reach?
- Are proper safety helmets, clothing, gloves, masks and respirators available?
- Is the worker equipped with lifeline, safety belt and life jacket—if he is to work at a height or above water?
- Is there protection against hazardous machinery, exposed electric wires, hot pipes or surfaces?
- Is the worker rightly oriented and trained, aware of his task and surroundings, his equipment and materials? Is supervision near?



## SECTION 1-3

### THE COMPOSITION OF PAINT

While the majority of protective coatings used in the Coast Guard are ready-mixed, a general discussion of composition is presented for general background information and to provide personnel with a better understanding of the potentialities and limitations of coatings.

In a broad general sense, paint is made essentially of 2 components—the pigment and the vehicle.

The *pigment* is a chemical compound in fine particle form which imparts color and opacity to a paint and, to a limited degree, determines its consistency and general characteristics such as durability, flexibility, fungus resistance, ease of application and, in special cases, fire retardancy and corrosion resistance. The pigment component of a paint may be a single pigment, but generally is a combination of two or more pigments.

The *vehicle* is the liquid component of a paint. The pigment is suspended in or carried by the vehicle. The vehicle is made up of a non-volatile and a volatile portion. The function of the non-volatile portion is to bind the pigment particles together and for this reason is often referred to as the “binder” by paint technologists. After evaporation of the volatiles, a continuous solid film is formed having the required characteristics of adhesion, durability, color retention, gloss and gloss retention, and, in metal primers, corrosion resistance. The function of the volatile portion is to thin the paint to the proper consistency for application as received. However, further thinning may be necessary in some cases. The volatile portion of the vehicle evaporates shortly after the paint is applied, the rate increasing with the tem-

perature of the surrounding air. Small amounts of driers are incorporated in the vehicle to accelerate the drying process which converts the non-volatile vehicle to a solid. They are usually compounds of lead, manganese, or cobalt naphthenates and act as catalysts in the oxidation and polymerization of the vehicle.

A factor which plays an important part in the characteristics of the dried paint film is the ratio by volume of the pigment to the non-volatile vehicle. In the dry paint film this determines the proportion of the pigment to the binder. Paints with a relatively large proportion of pigment have a flat or semigloss finish. Paints with a relatively large proportion of properly selected non-volatile vehicle are generally tough, durable, weather-resistant, and have a gloss finish.

The proper selection of raw materials and the quantities used of each depends upon the end use and is a job for a well trained paint technologist only.

#### 1-3-1, WHITE PIGMENTS

##### (A) TITANIUM DIOXIDE

Titanium dioxide is the most opaque and whitest of all pigments. Practically all white and light tinted paints contain titanium dioxide in varying amounts.  $TiO_2$  exists in 2 forms—*Rutile* and *Anatase*. Rutile is surface-treated with small amounts of aluminum oxide and resists chalking. Anatase tends to chalk more readily and it is, therefore, blended with Rutile in exterior house paints to obtain the desired self-cleaning properties. Most of the pigment produced is the Rutile type. Both types of

titanium dioxide are covered by Federal Specification, TT-P-442.

#### (B) ZINC OXIDE

Zinc oxide is a white pigment of relatively low opacity, but does add important properties such as hardness, mildew resistance, and color retention to a paint film. There are many grades of zinc oxide but the 2 major types for use in coatings are acicular (needle-like) and nodular.

#### (C) BASIC CARBONATE WHITE LEAD

Primarily used in combination with other pigments. Has low hiding power but in oleoresinous vehicles it forms metallic soaps which impart flexibility to the film.

Other white pigments used in paints are basic silicate white lead, basic sulphate white lead, antimony oxide, lithopone, zinc sulfide, and titanium-calcium.

### 1-3-2, COLOR PIGMENTS

There are 2 large classes of color pigments: inorganic and organic.

#### INORGANIC:

##### (A) LEAD CHROMATES—Yellows

##### LEAD MOLYBDATES—Orange

Both chromates and molybdates have good hiding power but tend to darken on outdoor exposure.

##### (B) IRON BLUES

Iron blues are chemical compounds resulting from the reaction of iron salts. Sodium or potassium ferri-ferro-cyanide, is deep blue in color. This group has fairly good durability and color retention when used as the major portion of the pigment in a paint.

##### (C) IRON OXIDE

Iron oxide pigments range in color from yellow to reds, browns and blacks. They possess very good opacity and durability and are comparatively inexpensive. The ores that occur naturally are commonly called earth colors. The manufactured types are termed synthetics and are used in automotive primers, roof paints and barn paints.

##### (D) CHROME YELLOW

Chrome yellow pigments range in color from light yellow to deep orange and may vary in composition from normal lead chromate ( $PbCrO_4$ ) to basic lead chromate  $PbCrO_4 \cdot PbO$ . They have good opacity, good durability, and reasonably good color retention.

##### (E) CHROME GREEN

Chrome greens are a combination of zinc yellow and iron blues and range in color from light shades of green to very deep greens. Due to their lack of chemical resistance, these pigments are not used in paints intended for use in corrosive locations. They also have poor color retention.

##### (F) CHROMIUM OXIDE AND CHROMIUM HYDROXIDE

Chromium oxide and chromium hydroxide pigments are green in color and are exceptionally durable and permanent. Chromium oxide has a somewhat dirty hue but has good opacity. Chromium hydroxide is a very clean light green with low opacity. These pigments are employed in the Spruce Green color used widely at shore establishments.

##### (G) LAMPBLACK

Lampblack, one of the most widely used pigments, is composed of fine carbon particles. It is made by burning oil under carefully controlled conditions. Lampblack is used for darkening the color of a paint and is used extensively in the various gray and black paints. Heavy concentrations of lampblack sometimes reduce drying properties of the paint when stored too long.

#### ORGANIC:

##### (A) TOLUIDINE RED TONERS

Organic pigments are often referred to as toners by paint chemists. Toluidine red toners are a group of organic red compounds covering a fairly wide range of red. They are durable and permanent when not diluted with white pigment, but possess low hiding power. They are cleaner and brighter in color than the iron oxides and are used extensively in paints where

### 1-3-3

brilliant color is an important factor. The most widespread single use of toluidine red toner in the Coast Guard is in the red enamel, Vinyl-Alkyd for Buoys. Toluidine red which cannot be used in amine-cured epoxies has been used satisfactorily in the polyamide epoxy type.

Numerous other organic pigments are used in the paint industry but space limitations preclude a detailed listing.

#### 1-3-3, EXTENDER PIGMENTS

Extender pigments are filler materials with little or no opacity. They are used primarily in limited quantities to increase the pigment portion of paints in order to control gloss, to diffuse or dilute other colored pigments, to retard settling and reinforce the film.

##### (A) MAGNESIUM SILICATE

Magnesium silicate is a fibrous-type talc in which the particle shape is a long needle-shaped crystal. When used in paint it tends to reinforce and strengthen the film. It also retards settling of the pigment. It is widely used in primers for metal surfaces.

##### (B) CALCIUM CARBONATE

Calcium carbonate is an extender used mainly to control the amount of pigment required in a coating in excess of that needed for hiding power and color. Commonly called whiting, it is also widely used in putty and calking compounds.

#### 1-3-4, SPECIAL PURPOSE PIGMENTS

The purpose served by the preceding pigments is primarily that of adding color hiding power and solids to the paint. The following pigments serve various special purposes as discussed below.

##### (A) RED LEAD ( $Pb_3O_4 + PbO$ )

Red lead has for many years been used to protect iron and steel against corrosion. The ability of red lead to inhibit corrosion is considered to be partly due to its slight alkaline nature. Steel and iron corrode less rapidly in an alkaline environment and it is believed that corrosion under a red lead film is suppressed because any moisture penetrating a red lead film is rendered alkaline by the red lead.

When used in conjunction with linseed oil or other paint vehicle, red lead has the property of penetrating into pits and crevices forming a tough, elastic adhesive paint film. Thus, red lead paints afford physical and chemical protection to iron and steel surfaces.

Red lead being low in the electromotive series may have some slight reaction when in direct contact with aluminum, zinc and magnesium-aluminum alloys. While the extent of this reaction is open to question it is considered better practice to use a zinc chromate primer for priming these metals.

##### (B) ZINC CHROMATE

The electrolytic theory of the corrosion of steel has created a special interest in chromium compounds. Because of the soluble chromate and mildly basic nature of zinc chromate, attention was focused on it as a corrosion-inhibiting pigment, and it became the subject of extensive investigations in primers for steel. Its use in conjunction with linseed oil has met with only moderate success because of the sensitivity of the binder to the water soluble portion of the pigment. Zinc chromate in an alkyd vehicle has given good performance when applied to very well prepared surfaces. Zinc chromate primers require excellent surface preparation for maximum performance.

##### (C) ZINC DUST

A possible explanation for the favorable results obtained in zinc dust pigmented primers for steel is the generally accepted theory that the finely divided zinc dust presents enough zinc surface to react with ingredients of the vehicle that would otherwise be free to attack and corrode the surface to be painted and disturb the bond between the metal and paint film. Another factor to consider is that the inhibiting qualities of metallic zinc and the mild neutralizing qualities of zinc oxide addition which tends to prevent an acidic condition, are both present in zinc dust. Zinc dust paint films are non-toxic. The combination of adherence, corrosion inhibition of steel, and non-toxic qualities is unique and has made zinc dust pigment suitable for use in coatings for the interior of metal potable water tanks.

#### (D) ALUMINUM PIGMENT

One of the most important properties of aluminum pigments is their ability to "leaf" when suspended in a properly formulated vehicle of oil or varnish. When aluminum paint is applied, some of the flakes are carried to the surface of the paint film and are held there by surface tension, forming an almost continuous metal leaf at the surface. The remainder of the flakes are distributed throughout the film in more or less parallel layers. Because of this arrangement it is difficult for air, light and moisture to penetrate the film. In order to promote "leafing" brush application should always be in one direction only.

Aluminum paint is more impermeable to moisture and oils than most interior or exterior enamels. Its hiding power is also extremely high. The combination of these two properties makes it an excellent sealer for wood treated with creosote or other petroleum preservatives and for sealing knots and resin pockets. It may also be used as a combined primer-sealer for overall application on wood surfaces, although products formulated for this particular function are generally preferred.

Its thermal emissivity is relatively low. This property makes it particularly valuable as a coating for boiler fronts and other heated surfaces where it is desired to reduce the amount of heat radiated.

Aluminum paint is sometimes used to reflect light, although its use for this purpose is declining. While the initial reflectance may approach that of ivory colored paints, discoloration of the surface through oxidation greatly reduces its reflectance. Also since its reflectance is high in specular reflectance, producing highlights, and low in diffuse reflectance, producing dark areas which contrast with the highlights, it is unsuitable for interior use as a high reflectance paint. White paint will reflect more light and heat than aluminum paint.

#### (E) COPPER AND MERCURY COMPOUNDS

These compounds have proved to be the most effective toxic ingredients for use in antifouling paints for both steel and wooden hulls. Cuprous oxide is the least expensive of the compounds and is the principal toxic constituent in most antifouling paints.

Mercuric oxide or mercuric chloride is frequently combined with cuprous oxide since the mercury compounds are more toxic to grass fouling. Antifouling paints used on wooden boats should not contain the mercury compounds since they may react with and destroy boat fastenings made of brass or bronze.

#### (F) ORGANO-METALLIC-TIN (TBTO)

This compound has shown some promise as an antifouling material, particularly over aluminum hulls. More testing and evaluation needs to be done before adoption. A coal tar epoxy antifouling paint using TBTO is now under study and evaluation. Other organo-metallic compounds are being developed for possible use as toxicants in antifouling paints.

### 1-3-5, OIL VEHICLES

Oil vehicles consist of a drying oil (an oil which dries to a hard non-tacky film), volatile solvent and drier. A combination of drying oils is sometimes used to obtain certain properties. All or a portion of the oil may be specially treated to improve gloss and leveling or to control penetration. Refined oil vehicles are used mainly in exterior paints for wood surfaces. Some of the more important oils used in paint formulations follow:

#### (A) LINSEED OIL

This oil is obtained from flax seed and has the ability to absorb oxygen from the air and eventually to dry, forming a tough hard film.

Linseed oil is of two basic types, i.e., raw and boiled. The raw or untreated linseed oil dries very slowly and has the ability to penetrate into the surface upon which it is applied. This material is used as the principal ingredient in the vehicle of "old-fashioned" slow drying red lead primers. These primers may take several weeks to dry thoroughly.

Boiled linseed oil is made by heating the raw linseed oil in the presence of air and driers to carry out a partial oxidation and polymerization of the oil, thus accelerating its drying.

Linseed oil is also frequently heat bodied by treating with heat to carry out a partial polymerization and produce a more viscous liquid. These treated oils (boiled and heat bodied) are often used as all or part of the vehicle in oil type house paints.

**(B) TUNG (CHINA WOOD) OIL**

This oil is obtained from the nut of the tung tree and must be heat treated before it is suitable for use in paints. It is often used in combination with resins to form an oleoresinous vehicle. This oil is less flexible than linseed oil but is more water resistant and chemical resistant. This oil is used in conjunction with linseed oil and phenolic resins in the formulation of many excellent spar varnishes and ready-mixed aluminum paints.

**(C) SOYBEAN OIL**

This oil is obtained by crushing soybeans. It is relatively inexpensive and has very good retention of color and elasticity. It is used extensively in modifying alkyd resin vehicles to impart non-yellowing properties to the finished paint. Its slow-drying properties are used to advantage in retaining the plasticity of calking compounds. Tends to lose drying properties under long-term storage.

**(D) FISH OIL**

An oil extracted from fish (usually menhaden) which has the property of withstanding high temperatures and is used in heat-resisting paints. It has rather poor drying properties and poor water resistance, but does impart good wetting characteristics. This oil is usually used in combination with other oils and resins in the production of oleoresinous coatings.

**(E) CASTOR OIL**

This is a non-oxidizing oil obtained from the castor bean and is used as a plasticizer in lacquer and other coatings. It can be converted into a drying oil by dehydration. Dehydrated castor oil has very good water and chemical resistance and is widely used in combination with resins to form oleoresinous vehicles. It is also used to some extent in synthetic alkyd finishes.

**1-3-6, OLEORESINOUS VEHICLES**

Oleoresinous vehicles consist of oils and natural resins cooked and blended together in various proportions. Vehicles can be formulated for either interior or exterior use, depending on the kind of resin and oil used and their proportions.

Oleoresinous vehicles are usually classified as short, medium or long oil varnishes, according to the proportions of oil and resin. A short vehicle contains less oil in proportion to resin than a medium or long oil vehicle. Short oil vehicles have high abrasion resistance but low resistance to moisture and hence are used primarily in interior paints. Conversely, long oil vehicles have low abrasion resistance but relatively high water resistance and are, therefore, used primarily in exterior paints.

**1-3-7, ALKYD VEHICLES**

Alkyd vehicles are made by the reaction of a polybasic acid, such as phthalic, isophthalic, maleic or succinic with polyhydric alcohol, such as glycerine or penterthritol, and vegetable oils or fatty acids from such vegetable oils as linseed oil, soybean oil, dehydrated castor oil and to a lesser extent, tung oil. The properties of this type of vehicle can be varied through a wide range depending on the type of polybasic acid, polyhydric alcohol and vegetable oil or fatty acid used.

The reaction of these components must be carried out in a closed reactor under controlled conditions in order to produce a uniform vehicle. When the reaction has been completed, the volatile portion is added to give the viscosity and solids content desired.

Pigments, driers, and thinners as used in straight oil paints are usually used in enamels formulated with alkyd resin vehicles. Straight alkyd resin vehicles should not be confused with vinyl-alkyd resin vehicles which require special thinners. Alkyd resin paints may be thinned with synthetic enamel thinner, Fed. Spec. TT-T-306.

The choice of alkyd vehicle to use in a given paint is controlled by the film properties and performance expected of the product. Many alkyd vehicles are compatible with oils and oleoresinous vehicles and are often used in this manner to give improved durability and service characteristics to the finished coating. Alkyd paints, properly formulated, have excellent durability, water and chemical resistance, and generally give better performance than the older drying oil vehicles.



### 1-3-8, PHENOLIC RESIN VEHICLES

Phenolic resins are made by condensing phenol with formaldehyde or similar aldehydes. These resins are commonly used in combination with one of the oils to produce a vehicle which has excellent water and chemical resistance. Phenolic resins have a marked effect on the polymerization of oils which is evidenced by a more rapid drying of the film. They also have an inhibiting effect upon the oxidation of the oil after the initial drying cycle. This tends to prolong the life of a film, since all paint films ultimately fail due to a long slow oxidation period. An example of phenolic resin vehicle is Spar Varnish which is formulated of phenolic resin, linseed oil, tung oil, petroleum spirits, xylene, and driers. This formulation shows excellent durability on exposure, good abrasion resistance and gloss retention.

### 1-3-9, VINYL RESIN VEHICLES

The term "vinyl resin" is usually employed to define a class of synthetic resins derived from a vinyl ester, such as vinyl acetate, vinyl chloride, vinylidene chloride, etc. by polymerization of the monomeric compounds under conditions which are controlled to yield products of the desired characteristics. In contrast to the preparation of phenolic, urea and alkyd resins, which are formed by a condensation process, the vinyls are formed by polymerization. As a result, each polyvinyl resin molecule consists of a linear chain in which the monomers have reacted with one another to form high molecular weight polymers.

The characteristics of the vinyl resins are closely associated with their molecular weights. Certain properties of the vinyl resins vary with the molecular weight, while others seem to be completely independent of it. For example, tensile and impact strength, abrasion resistance and solution viscosity increase with the molecular weight of the polymer, whereas water absorption, refractive index, hardness, and electrical properties are practically independent of molecular size. The solubility of the resins in organic solvents varies inversely with the molecular weight.

There are six types of vinyl resins which find applications in the plastics and coatings fields: (1) polyvinyl acetate, (2) polyvinyl alcohol, (3) polyvinyl chloride, (4) copolymers of vinyl chloride and vinyl acetate, (5) polyvinyl butyral, and (6) polyvinylidene chloride and copolymers with vinyl chloride.

Pretreatment-Wash Primer is formulated from the polyvinyl butyral which is alcohol soluble. Cleaning brush and spray equipment and thinning when necessary requires denatured ethyl alcohol or isopropyl alcohol.

Vinyl anticorrosive paint and vinyl alkyd topcoat paints are formulated from the vinyl chloride-vinyl acetate copolymer. Cleaning brush and spray equipment, and thinning when necessary, requires methyl isobutyl ketone and toluene. These solvents are conveniently combined in one container listed in the catalog as Vinyl Paint Thinner.

Vinyl paints form an exceedingly tough and durable film. They are more resistant to alkalis than most paints and may be scrubbed with highly alkaline cleaners. Vinyl paints must have a chemically clean surface and surface pretreatment of wash primer for proper adhesion.

### 1-3-10, CHLORINATED RUBBER VEHICLES

Chlorinated rubber resin is a rubber solution vehicle obtained by dissolving milled rubber in toluene and introducing chlorine gas. The chlorinated product is then precipitated by discharging the solution into water which produces a white granular solid. The precipitate is then dissolved in coal tar or chlorinated solvents and necessary plasticizers added. Coatings made with chlorinated rubber vehicles are quick drying and resistant to water and most chemicals, particularly alkalis. For this reason they find application to concrete surfaces. Chlorinated rubber base paint may be thinned when necessary with aromatic petroleum naphtha.

### 1-3-11, SILICONE VEHICLES

Silicone vehicles are synthetically produced from siloxane intermediates and a wide range of silicone vehicles can be produced by varying

the molecular properties of the various intermediates. The chief value in silicone paints lies in their unusual resistance to high and low temperatures. Due to high cost, the use of silicone paints is limited to application where severe conditions of corrosion and high temperature are present. Protective coatings formulated of this vehicle require the use of coal tar solvents, such as toluene, if thinning is necessary for proper application consistency. Properly formulated silicone vehicle insulating varnishes exhibit remarkable electrical insulating properties at high temperatures. They have, however, poor package stability.

### 1-3-12, EMULSION VEHICLES

Emulsion vehicles consist of oils, resins, nitrocellulose or other organic binders emulsified in water. The vehicle is dispersed throughout the emulsion in fine droplets and is called the dispersed phase—the water being called the continuous phase.

Emulsion paints may have the following components, some of which are briefly discussed in the following paragraphs:

- Hiding Pigment
- Extender Pigment
- Resin
- Emulsifying Agent
- Preservative
- Thickener
- Antifoam Agent
- Fungicide\*
- Freeze-thaw Stabilizer\*
- Water
- pH Buffer

\* Optional, depends on end use

Pigments used depend upon the end use of the paint. In general, most pigments used in oil paints are suitable for use in emulsion paints.

The choice of resin for use in emulsion paint is governed by costs, availability and performance requirements. Resins are generally used without organic solvents to avoid odor and fire hazard.

The purpose of the emulsifying agent is to prevent the coalescence of the droplets of the dispersed phase. They are principally soaps and may be added as such or formed during the emulsification. A film of the agent is formed around each droplet of the dispersed phase

only a few molecules thick. The emulsifying agent must, therefore, be resistant to physical and chemical changes.

The stabilizer is used to reduce consistency change or actual breaking of the emulsion caused by variations in temperature, mechanical working or other abnormal conditions. Stabilizers used include casein, soya protein, methyl cellulose, starches and others.

Antifoaming agents are required to reduce the large quantity of foaming produced by agitation in the manufacturing process. A similar condition exists when the painter brushes the paint on a wall. The brushing action may produce considerable air bubbles which do not break until the film is partly set. This produces a pitted surface in the dry film and is undesirable.

Metallic driers are necessary in emulsion paints which contain oxidizable oils and resins for the same reasons that they are necessary in oil paints.

The volatile material in emulsion paints is principally water; although volatile emulsifying agents are frequently used and there may be small amounts of organic solvents derived from driers or antifoaming agents present.

A properly formulated emulsion paint is stable over the normal temperature ranges, but the emulsion may be broken by freezing or by temperatures in excess of 160° F. Obviously if the continuous phase (water) is frozen, the condition at the interface changes from a liquid to a solid which upsets the balanced film of emulsifying agent concentrated there. Sometimes the emulsion may be reformed by sufficient agitation but this is not always possible. When the temperature is raised above 160°F., the viscosity and interfacial tension changes, and again the balanced film of emulsifying agent is destroyed. A proper balance of stabilizers improves heat stability but there are definite limitations in this direction.

Emulsion paints produce excellent flat finishes with very low sheen. They are easy brushing, fast drying, have good dry hiding power, lack objectionable paint odor and present no fire hazard during storage or application. Brushes and equipment are easily cleaned after use. Emulsion paints should not be applied over a chalky surface.

### 1-3-13, EPOXY VEHICLES

A relatively recent synthetic resin which can be dissolved in a proper solvent (ketones, esters, nitroparaffins) to form a vehicle. Epoxy resins are derived from a coal tar derivative called bisphenol A and an anhydride substituted product formed from glycerine called epichlorohydrin. The key reactive portion of the resin,

as its name implies, is an epoxy group  $\begin{array}{c} | \quad | \\ \text{---C---C---} \\ | \quad | \\ \text{O} \end{array}$ .

Just prior to application a curing agent or hardener is added which reacts with the epoxy resin to form a hard and tough compound. The curing agents most commonly used are of two general types:

- (a) An organic amine
- (b) A polyamide

Catalyzed epoxies are outstanding for their chemical resistance and solvent resistance. One disadvantage is their tendency to chalk rapidly which affects adversely the color retention and appearance of pastel colors. Where self cleaning action is desired this property is helpful.

The most commonly used solvent for catalyzed epoxies is methyl isobutyl ketone. Ketones also have a high tolerance for aromatic diluents. Other active solvents include alcohols, esters, ethers, nitroparaffins and chlorinated hydrocarbons. Aromatic solvents such as xylene are weak solvents and are used primarily as diluents.

Another type of epoxy vehicle which should be mentioned is the epoxy ester type. This is a one-package material and does not require the addition of a curing agent. The epoxy esters are often referred to as modified epoxies.

The epoxy ester is produced by heat reacting the epoxy resin with vegetable or fatty acids. The resultant compound can be thinned with xylene and mineral spirits and dries by solvent evaporation and oxidation of the linseed, soya or tall oil modifier. The rate of dry is accelerated by the use of cobalt naphthenate.

The air dry epoxy ester coatings are less resistant to chemicals and solvents than the 2-component epoxy coating and should not be accepted as a substitute.

Other uses of epoxies include adhesives, flooring compounds, potting compounds, laminates, foams, body solders and patching compounds.

### 1-3-14, SOLVENTS AND THINNERS

In the manufacture of paints and varnishes, solvents which have the ability to dissolve the resin and oil combinations and to achieve the proper consistency for application must be used. Since the solvents evaporate when the paint is applied, the proportion of solvent to solid used in a paint determines the thickness of the dry film per coat. In order to obtain satisfactory dry film thickness, solvents should be used only in such quantities as are required to render the proper consistency for application. Excess thinning of paint reduces its dry film thickness per coat, resulting in lower ultimate life, especially so if the finish is exposed to the elements.

Oil, oleoresinous, alkyd and phenolic vehicle paints are compatible with petroleum distilled solvents such as naphtha and mineral spirits. A solvent of this type is stocked under the name of Paint Thinner. Turpentine has been considered a general all-purpose thinner for many years. However, due to its high cost, its use is not justified since mineral spirits, a mixture of straight chain hydrocarbons will satisfactorily thin most paints used in the Coast Guard and the cost is considerably less. In addition, turpentine is a vegetable derivative as contrasted to petroleum solvents which are mineral oils. Turpentine is, therefore, more of a fire hazard due to the danger of spontaneous combustion as discussed in Section 1-4, Storage of Paint Materials.

Many coatings formulated from synthetic vehicles are not compatible with petroleum distillates and therefore require thinners of higher solvent power such as the coal tar distillates—toluene, xylene, and solvent naphtha or the hydrogenated naphthas which are made from petroleum distillates by chemical treatment. These distillates are sometimes used in combinations to obtain varying power of solvency. An example of this type is Synthetic Enamel Thinner which has intermediate solvent powers, and Vinyl Paint Thinner which has high solvent powers.

**1-3-15, JOB-MIXED PAINTS PROHIBITED**

As previously stated, this discussion of raw materials used in the manufacture of paints is purely for informational purposes and shall not be construed as authority for mixing paints "on the job" from raw materials.

The correct formulation of protective coatings is a job for a paint technologist and requires a great deal of experience and a thorough knowledge of the properties of the basic materials used in the coatings. There are a large number of pigments, oils, resins, solvents, and driers and an infinite number of combinations of these constituents. Only experienced formulators can produce coatings with the properties required to give best results. Furthermore, mixing is only one step in the process of paint manufacturing. Proper dispersion of the pigment is necessary, requiring the use of paint mills and other equipment designed especially for the purpose. For these reasons, USE OF "JOB-MIXED" PAINTS IN THE COAST GUARD IS PROHIBITED.

In the event an inferior paint is received from a Coast Guard supply source, all pertinent information including the name, stock number, manufacturer's name, contract number as stenciled on the exterior of the container together with details of the method of application and nature of the paint failure should be furnished to the Commandant (FS).

Inferior paints received from General Services Administration sources should be reported to the supplier, Regional Office of GSA, with a request to return the paint for credit or exchange.

In the event an appropriate type of paint for a particular application is not available through GSA or Coast Guard supply channels, the Commandant (FS) should be informed of this situation, also giving the details of the purpose for which the paint is to be used.

**1-3-16, THE MANUFACTURE OF PAINT**

The majority of Coast Guard paints are manufactured to Federal, Military or Coast Guard specifications. These specifications are written around formulations made by experienced paint technologists. Since paint formulation is not an exact science, many trial formulations are prepared and subjected to laboratory tests. The

most promising of these are then service tested for several years before a final selection is made of the best formulation for a particular job.

Specifications are then written which set forth the formulation and/or the physical properties of the paint, the requirements for the raw materials and test methods for determining whether the materials meet these requirements. These specifications are furnished to the paint manufacturer with an "invitation to bid" on the paint involved.

The first step in the manufacturing process consists of the blending of the required pigments, oils, resins, driers and solvents in a mixing tank. The liquid ingredients are pumped from supply tanks at ground level up to the mixing tank which is generally located on the highest floor of the plant. There they are introduced into the mixing tank. Not all of the liquid ingredients are put in the mix at this time. Generally speaking, the more volatile liquids such as some of the solvents are added at a later stage to prevent their loss by evaporation during the manufacturing process. The pigments are then weighed out to get the proper amounts of each and added to the liquids in the mixing tank. The mixture is then mechanically agitated to form a homogenous mix about the consistency of syrup.

This mix is then fed down to the next level in the plant where it is placed in the "mills." Mills of two types, i.e., pebble (ball) mills and roller mills, are widely used. Pebble mills are large cylinders about 1/3 filled with pebbles or steel balls approximately the size of marbles. The mix is fed into the pebble mill where it is "ground" by revolving the mill for a period of from 8 to 24 hours. Grinding is necessary to insure thorough wetting and complete dispersion of the pigment.

Roller mills achieve the same grinding result by running the mix between steel rollers which are rotating at different speeds and in opposite directions. The lower rotating cylinder picks up the paste on its surface and carries it around to where it is squeezed or ground between the upper and lower cylinders. This paste is run through 3 to 5 such sets of rollers. Each pair of rollers is set successively closer together. Roller mills are used for very fine grinds.

Other grinding equipment types used by the paint industry includes the high speed mixer and the sand mill grinder.

After the paste is ground it is fed to the next lower level where the remaining solvents are added to achieve the desired consistency of the finished paint. This is done in a mechanically agitated mixing tank. When all the ingredients have been mixed together the paint is tinted to the proper color by adding small portions of liquid tinting material.

The finished paint is then piped to the ground level of the plant where it is packaged for delivery. Either prior to or immediately after delivery random samples of the paint may be selected by a Government inspector and subjected to a series of rigorous chemical and physical tests in the laboratory to determine if they have been formulated in accordance with the specification. If the paint passes all requirements it is accepted and placed in stock for issue. In other instances all tests are made by the manufacturer and certified by him that the paint conforms to the specification.

### 1-3-17, HAZARDOUS PAINT MATERIALS

Many paints and solvents are hazardous. They may be highly flammable, injurious to the eyes and skin, dangerous for their vapors, dangerous if swallowed. Examples here would be vinyl solvent coatings and epoxy coatings—among several others. To be on the safe side at all times, the following rules and precautions should be observed.\*

(a) Store materials in well ventilated areas, away from heating equipment and open flames, and away from direct sunlight.

\* THE HEAVY BODY MASTIC, INSULMASTIC IS ALSO HAZARDOUS DURING APPLICATION. THE SPRAY GUN SHOULD BE GROUNDED TO GUARD AGAINST EXPLOSION OF FLAMMABLE VAPORS.

(b) Keep containers tightly closed at all times. Check stored containers frequently for seeping or bulging. Containers which are bulged from inside pressure shall be disposed of.

(c) Avoid sparks or open flames near open containers. Extinguish all pilot lights on water heaters, furnaces, or other equipment, on all levels. *Do not smoke* while mixing or applying these materials. No welding, grinding, cutting shall be allowed in close proximity to painting operations.

(d) Do not work in any area or enclosure when air is not clear and free of excessive solvent odor. Exhaust air from lowest level, where possible.

(e) Use Bureau of Mines approved type chemical respirator during outdoor spraying operations or when applying coatings by brush or roller in confined areas. Air-supplied respirators shall be used during spraying operations in any confined area.

(f) Use only vapor-proof and explosion-proof electrical equipment in confined areas.

(g) Wear only rubber soled shoes and clothing free of ferrous metal parts when working in confined areas.

(h) Always use drop cloths under materials supply cans, spray pumps, and pots and avoid dropping of cans or equipment in metallic or concrete enclosures.

(i) Avoid contact of coatings or compounds with the skin for prolonged periods. Wash face, hands, arms, and other exposed areas of the body at least every two hours, using soap and water. Trust commercial protective creams for short periods of time only. Wash clothing regularly. Personal hygiene is highly important when working with epoxies.



## SECTION 1-4

### STORAGE OF PAINT MATERIAL AND RELATED ITEMS

#### 1-4-1, GENERAL

When paint is stored—whether aboard ship or at a shore station—it should always be placed in a paint locker. The cans should be marked with the name of the paint, the formula or specification number, and the date of manufacture—and kept tightly sealed. To prevent settling, all cans should be turned “bottoms-up” at least once every three months. Be sure the lids are tightly sealed before turning. (Note: This does not apply to Supply Center or Depots; special directives have been issued for these Activities.)

When new stocks of paint are received, they should be stored so that the oldest stock is used first. Reduce the paint stores to the lowest practical limit and maintain only necessary stock. All paints received which are over 15 months old, and which do not carry a notation of inspection within the past 12 months, shall be examined by opening 2 to 3% of the cans in each manufacturer's batch and determining whether the paint is usable. “Usable” paint is that in which the pigment and vehicle can be thoroughly mixed by mechanical paint shakers, motor driven stirrers, or hand stirring, to a smooth consistency in a reasonable time. The fact that the pigment has settled into a mass and requires loosening by hand scraping does not, alone, mean that the paint is not in satisfactory condition. Information on unusable paint received from a Coast Guard source of supply shall be referred to Commandant (FS) for disposition instructions. All paint received from Navy or GSA sources should have a notation on the containers indicating the time and place of an examination within the past 12

months if the material is over 2 years old. Navy or GSA supplied paint which does not have this notation or which is found to be in unusable condition shall be brought to the attention of the supplier with a view toward returning the paint for credit or replacement. Unusable paint received from other sources shall be handled in the same manner.

#### 1-4-2, FIRE AND HEALTH HAZARDS IN PAINT STORAGE AND MIXING

Particular caution must be exercised in the storage and mixing of paint to reduce personnel health and fire hazards. Paint stored in a tightly closed container is not extremely hazardous; the hazard occurs when the top is left off the can, or when the lid is not tightly closed. Volatile liquids of the paints will vaporize when exposed to the air, and vapors escape into the paint locker where they may be ignited and explode when they come into contact with a spark, open flame, or other source of heat. The principal hazard exists therefore in the area in which the paint is being mixed. It is desirable to limit the amount of paint in this area and to store the bulk of the paint in the area separated from the mixing. Only that paint which is to be mixed during the day should be present. These volatile liquids may also cause asphyxiation of personnel working with or in the immediate area of paints being poured or mixed or from any leaky container in any confined area. Paint left over from the day's work shall be tightly closed and returned to the paint storage room. Rags, rope, and other combustible material shall be kept clear of the

paint mixing room. Wet brush stowage tanks (see Article 1-7-5) shall be provided with sheet metal covers to prevent evaporation of volatile solvents. Used rags and empty paint containers shall be disposed of, since they constitute a fire hazard.

Spontaneous combustion must be guarded against in paint lockers. Oils of vegetable origin dry by oxidation, and the oxidation process gives off heat. If this heat cannot escape, as when the oxidation takes place in the center of a pile of rags, it accumulates to the point of igniting the organic materials, and fire results. Linseed oil, turpentine, and fish oils are of organic origin and rags soaked in these oils are fire hazards. Rags soaked in oils of organic origin should be stored in closed non-combustible containers, away from any combustible material, or be disposed of by safe means. The high fire hazard of organic or vegetable oils is one of the reasons leading to the replacement of turpentine by mineral spirits as a solvent. Mineral spirits evaporate rather than oxidize, and the vapors are carried away in the atmosphere. The evaporation process soaks up heat rather than accumulating it as does the oxidation process. Thus, no spontaneous combustion will be caused by evaporation of mineral spirits. However, ventilation is important to rid the area of the vapors, which are highly explosive when in the proper mixtures with oxygen of the air. In any case, containers of paints, paint thinners, paint removers, and all associated or similar materials, must be kept sealed, and all rags or organic solid materials removed from the area, and protected from any possible sources of ignition. **SMOKING IN PAINT LOCKERS OR IN PAINT MIXING AREAS IS ABSOLUTELY PROHIBITED.**

### **1-4-3, PAINT STORAGE AT SHORE STATIONS**

#### **(A) UNOPENED PAINT**

At shore stations, unopened paint can be kept in a general station storage room subject to the following conditions:

(a) Ambient high and low temperatures of the general storage area must be well within the temperature tolerances required for safe protection of the paints involved.

(b) Storage of the unopened paint in the general storage room shall be accomplished so as to preclude damage to the paint containers by movement of paint or other material stored in the room.

(c) No operation shall be conducted in the general storage room which will produce heat, spark, open flame or other abnormal sources of heat.

(d) Absolutely no paint will be opened or mixed in the general storage room.

(e) No paint container which has been opened for any reason shall be stored in a general station storage room.

Separate paint storage buildings are not required. Existing small buildings or areas of buildings can be used for paint storage when suitably prepared for the purpose.

#### **(B) OPENED PAINT**

Storage areas for paint containers which have been opened must meet specific applicable requirements, whether stored in a separate small building or a part of a larger building.

General requirements for storage of paint containers which have been opened include:

(a) The paint storage room should be located where the ambient temperature will be kept as low as possible during the summer months, and where adequate natural ventilation will be available. Where the ambient temperature exceeds 90°F. in the storage room, paints may vaporize sufficiently to cause pressure to build up in the can and escape into the storage room.

(b) The paint storage areas shall be isolated from heat sources such as furnaces, forges, and welding activities, and protected from areas of other combustible material and hazards. Fixed louvered ventilators shall be provided at the ceiling and at the floor of the paint storage area to the outside of the building to allow lighter and heavier-than-air gases to escape. Precautions should be taken to assure that escaping gases dissipate to the outside air and do not re-enter the building or become trapped under the eaves. No paint mixing or open cans will be permitted in the paint storage area. Water emulsion and other non-flammable paints shall be stored in a frost-proof storage, apart from the flammable paint storage, if necessary, to provide protection against freezing temperatures.

Specific requirements for opened paint container storage rooms which are part of a larger building include:

(a) The walls, ceiling and floors shall be of fire-resistant material, or paint shall be stored in special lockers designed for the purpose, and as approved by the Commandant. At small stations, National Fire Protection Association approved storage cabinets manufactured by the Protectoseal Company or equal are acceptable where paint storage and thinners will not exceed 45 gallons. Access to the paint storage room should be from the outside of the building only, with no connection to other rooms in the structure.

(b) Paint storage rooms shall not be located in basements or where vapors heavier than air cannot escape from the ventilated room.

At large shore stations where painting is a major function of the unit or a large maintenance item, paint mixing shall be done in existing paint spray booths with forced draft ventilation systems in operation, or shall be done outdoors. During inclement weather and in the absence of other acceptable mixing areas, paint mixing may be done indoors in well-ventilated areas.

At small shore stations where paint booths or shelter are not provided or warranted, paint mixing shall be outdoors, or during inclement weather, in well-ventilated areas. Adequate ventilation must be provided in rooms where paint is mixed to prevent the concentration of explosive volatile vapors. Precautions should be taken to prevent escaping gases from re-entering the structure.

Paint lockers are sometimes equipped with automatic or remote controlled carbon dioxide (CO<sub>2</sub>) extinguishing systems, coupled with fire alarms. Another protection for paint lockers at shore stations is a sprinkler system, which will usually extinguish the fire, or at least control it until personnel can apply other means of extinguishment. Automatic sprinkler systems will further provide a cooling effect to paint containers exposed to possible combustion, and prevent their involvement. The water will not affect paints in cans which have not ruptured, and will protect them while controlling the fire. A sprinkler system should be installed in paint storage lockers at major units

where large paint storage requirements exist. The preferred first aid extinguisher for all sprinklered or non-sprinklered paint storage rooms is the dry chemical type, of adequate size to cope with the maximum potential Class B fire hazard. (See current Engineering Instructions.) The recommended minimum size dry chemical fire extinguisher for this use is the ten-pound capacity unit. However, any hand portable fire extinguisher should be backed up by adequate supplies of water. Although the use of the carbon dioxide (CO<sub>2</sub>) flooding type system is acceptable, it is expensive in original cost as well as in personnel time and work requirements for maintenance purposes. The replacement of existing hand portable carbon dioxide extinguishers with dry chemical type extinguishers is strongly recommended. Also, the use of sprinkler systems is generally preferred to the use of the fixed carbon dioxide flooding systems. Inspection and maintenance requirements for fire protection facilities are covered by Coast Guard Regulations and existing directives.

#### 1-4-4, SHIPBOARD STORAGE OF PAINTS

Proper stowage of paint on shelves and in racks is even more important aboard ship than ashore. Only those containers actually being used should be left on the deck and the battens provided should be kept installed at all times except for the brief periods when their removal is actually required. Cans of paint, open or closed, should not be left out of their proper stowage, unattended, particularly when the vessel is at sea. Shipboard personnel shall have complete knowledge of the safety precautions defined in Article 1-3-17.

The paint lockers and paint storage spaces, if separate compartments, are normally equipped with a fixed-flooding type of CO<sub>2</sub> installation. The larger installations are equipped with a CO<sub>2</sub> release alarm system to warn by visible and audible alarms that the system has been discharged. The fixed-flooding system is also connected to a switch which secures the ventilation to these spaces as the CO<sub>2</sub> is released. On smaller vessels, paint storage areas are protected by the CO<sub>2</sub> and/or dry chemical type portable extinguishers.



All shipboard personnel, but in particular paint locker personnel, should be thoroughly familiar with the operation of the fire fighting equipment installed on their particular vessel. Chapter 93 of the Bureau of Ships Technical Manual gives instructions for the operation and testing of both the installed and portable fire fighting systems. 15 lb. CO<sub>2</sub> cylinders must be weighed monthly, and recharged when the weight drops to 13½ lbs. Cylinders of 35 and 50 lbs. must be weighed semi-annually, and

replaced if the weight has dropped to 31½ lbs. or 45 lbs. respectively.

Remote control devices shall be tested whenever the CO<sub>2</sub> cylinders are disconnected from the system for weighing. Upon being discharged, an extinguisher shall be replaced with a full one immediately and the discharged one recharged at the first opportunity. Never return an empty or partially empty extinguisher to its rack.



## SECTION 1-5

### SURFACE

### PREPARATION

The proper preparation of the surface to be painted is the most important single factor in securing good paint performance. Time spent in careful surface preparation will be more than repaid by the additional life of the paint film.

#### 1-5-1, PREPARATION OF METALLIC SURFACES (Except Aluminum and Galvanized Steel)

Metallic surfaces other than aluminum and galvanized steel should be cleaned by dry sandblasting wherever possible. This removes all mill scale, rust, oil and foreign matter and leaves a chemically clean surface which will insure best paint performance. Immediately upon the completion of the sandblasting 1 liberal coat (at least 0.5 mil film thickness) of Pretreatment-Wash Primer shall be applied. If the bare sandblasted surface is allowed to stand overnight a thin film of rust, often invisible, will form on the metal nullifying to a large extent the advantages of the sandblasting. If the surface cannot be coated with Pretreatment-Wash Primer the same day it is sandblasted, it shall be washed with a rust inhibitor solution consisting of a mixture of 4/5 qt. of dry diammonium phosphate, 1/5 qt. of dry sodium nitrite and 40 gals. of water. The Pretreatment-Wash Primer shall be applied as soon thereafter as possible.

Wet sandblasting shall be used where dry sandblasting is impracticable, and where the volume of metal cleaning makes manual methods uneconomical. It is particularly well suited to use at bases and depots not having

an area remote from docks or shops available for dry sandblasting. A rust inhibitor solution shall be used in both the sandblasting slurry and the final water wash. The rust inhibited slurry shall consist of 1/5 qt. sodium nitrite, 4/5 qt. diammonium phosphate, 15 gals. of water and 300 lbs. of sand. In the final operation of washing down the sand from the blasted area the water wash shall consist of 1/5 qt. sodium nitrite, 4/5 qt. diammonium phosphate and 40 gals. of water. One liberal coat (at least 0.5 mil film thickness) Pretreatment-Wash Primer should be applied as soon as the water-washed surface has begun to dry. It may be satisfactorily applied to damp but not thoroughly wet surfaces.

Where sandblasting methods are not practicable, manual methods may be used. The surface should first be roughened by the use of roughing tools such as chipping hammers and scrapers. In the use of these tools care must be taken to prevent nicking, denting or scratching of the surface. Nicks, dents and scratches provide ideal starting points for early failure of paint films. The low portion of such surface irregularities are difficult to clean and become a source of corrosion. On the sharp edged high points only a thin film of paint will adhere causing early paint failure. Chipping hammers should never have a chisel sharp edge. Thin plate (under 3/16 in.) should never be chipped but should be scraped and wire-brushed.

When the bulk of rust and old paint has been removed by roughing tools, finishing tools shall be used to complete the job. The principal finishing tools in use are hand wirebrush, electric and pneumatic wirebrushes, power driven

abrasive wheels, discs, or belts, and sandpaper. The use of finishing tools without prior use of roughing tools usually results in low productivity in terms of area finished per unit time, or in the case of power wirebrushing, in poor surface preparation due to "glazing" rather than removing particles of rust and old paint. The hand scraper is used on small jobs where power tools are impractical and on flat surfaces, crevices and corners. The hand wirebrush is a useful tool for light rust and for brushing around welds and in places not accessible to the power wirebrush. Sandpaper and sanding discs are used where a particularly smooth, clean surface is desired. Also where old paint is removed only in spots, the edge of the remaining paint film should be sanded so that it tapers down to the bare metal. This will give a uniform appearance to the new paint film. Steel wool should not be used as a substitute for sandpaper since small steel particles become embedded in the paint and form a source of corrosion. After the finishing operation is completed brush the surface to remove paint chips, dirt and dust and immediately apply 1 liberal coat (at least 0.5 mil film thickness) of Pretreatment-Wash Primer.

No rust inhibiting treatment other than the above shall be used. Specifically, phosphoric acid inhibitors are no longer authorized for Coast Guard use because of the following factors: (a) the erratic performance of water solutions of phosphoric acid, (b) the necessity for careful control of more complex phosphoric acid solutions to obtain consistently favorable results, (c) phosphoric acid inhibitors reduce effectiveness of Pretreatment-Wash Primer, and (d) use of phosphoric acid seldom produces detectable improvement in the paint performance of all paint systems.

All ungalvanized steel surfaces to be painted shall be treated as above with the exception of potable water and feed water tanks. In the case of these tanks omit the use of the Pretreatment-Wash Primer. For information pertaining to interior painting of potable water tanks, see Article 2-3-7.

**CAUTION.** When applying Pretreatment-Wash Primer on interior surfaces, care must be taken to assure adequate ventilation and fire precautions must be strictly enforced.

### 1-5-2, PREPARATION OF ALUMINUM SURFACES

Sandblasting and wirebrushing aluminum surfaces are not recommended except in cases of severe corrosion. Solvent cleaning is usually all that is necessary and may be accomplished by washing the surface with Paint Thinner after brushing off dirt and dust. Follow the Paint Thinner wash by washing with Paint Cleaner and water. Rinse with fresh water.

On exterior previously painted surfaces, old defective paint coatings may be removed with Paint and Varnish Remover. Since Paint Remover contains wax, the surface, after removing the old paint, must be washed with Paint Thinner, followed by Paint Cleaner and water. Paint Remover is not recommended for use on interior surfaces.

On interior previously painted surfaces, old firmly adhering paint coatings should not be removed. Flaking, scaling or peeling patches may be removed with hand scrapers, but great care must be taken not to damage the aluminum surface. Dulling the corners of scrapers will help prevent nicking the aluminum. The edges of firmly adhering paint around cleaned patches may be faired with fine sandpaper. Do not sandpaper the aluminum surface. After scraping and sanding, wash the entire surface with Paint Thinner followed by washing with Paint Cleaner and water and a fresh water rinse.

### 1-5-3, PREPARATION OF GALVANIZED STEEL SURFACES

Heavy blast cleaning of galvanized steel shall be avoided. However, it is frequently necessary to blast clean these surfaces to remove corrosion products and to roughen the galvanize in order to obtain good paint adherence. In doing this, the nozzle of the hose should be held at a greater distance from the surface and the abrasive sprayed more rapidly over the surface than is normally done. With adequate care, the galvanize coating will not be removed from the surface during this light cleaning. Immediately after this cleaning, sweep or blow the dust off of the surfaces and apply 1 liberal coat of Pretreatment-Wash Primer.

Chipping hammers shall not be used on galvanized surfaces. Old paint shall normally be removed by means of a hand scraper and/or hand or power wirebrushes if blast cleaning equipment is not available.

After scraping and/or wirebrushing a galvanized surface, it shall be wiped with Paint Thinner to remove residual paint and contamination. As soon as the surface is dry, apply 1 liberal coat of Pretreatment-Wash Primer.

#### 1-5-4, PREPARATION OF WOOD SURFACES

##### (A) BARE WOOD

Bare wood surfaces shall be planed or sanded to a smooth surface. The degree of smoothness is determined by the use to which the surface will be placed.

Plastic wood shall be used to fill cracks and holes. If the wood is to be subsequently varnished or lacquered the plastic wood can be stained to match the color of the wood. The plastic wood will harden sufficiently within four hours to withstand ordinary handling and the use to which it will normally be subjected. When dry it can be cut, sawed, bored, reamed, filed and will withstand, without cracking, the driving of nails into it.

Putty may be used for filling nail holes, worm holes, dents and cracks where no strength is required. Putty should never be applied to bare wood because the oil in the putty will be absorbed by the wood and cause the putty to dry out, crack and eventually fall out. Holes to be puttied must first be primed with either a regular primer or with paint.

Wood which will be subjected to moist conditions, placed in or close to the ground and all exterior wood shall be treated with wood preservative. Pressure treated wood shall be used where severe conditions are encountered. Where a moderate amount of protection will suffice treat the wood with 2 coats of Copper Naphthenate Wood Preservative. The preservative shall be swabbed or brushed on, applying as much of the preservative as the wood will absorb. Joints and end grain surfaces shall be thoroughly soaked with the preservative. The preservative shall be allowed to dry 72 hours before application of paint to avoid bleeding.

In cases where the structure is of a temporary nature or where periodic treatment is necessary due to causes other than decay, preservative treatment may be omitted.

On interior surfaces where appearance is not important, such as wooden boat bilges, the wood shall not be painted. Painting tends to prevent the normal ventilation from reaching the wood thereby increasing the opportunity for the wood to rot. It also makes it impossible to renew wood preservative until the paint has peeled off or been removed. By omitting the paint, the surfaces may be inspected to ascertain whether or not the wood should be retreated. As long as the green color of preservative is clearly visible, the material is effective. When the green color is no longer visible, danger of rot exists. The wood shall be retreated at such intervals as to maintain a clearly visible green coloration.

Wood which is to be placed in soil or submerged in water shall be pressure treated with coal tar creosote in accordance with the current edition of Federal Specification TT-W-571. Creosoted wood which is to be subsequently painted shall be weathered for 90 days and given 1 coat of Ready-Mixed Aluminum Paint.

Subsequent to preservative treatment, if used, knots and resin pockets shall be sealed to prevent the resin from bleeding through the paint. Remove all excess resin by scraping and coat the affected areas with Ready-Mixed Aluminum Paint.

##### (B) PREVIOUSLY PAINTED WOOD SURFACES

Previously painted wood surfaces shall be thoroughly washed and cleaned of all foreign matter. The use of alkaline solution such as lye or trisodium phosphate is prohibited. Paint Cleaner, a synthetic detergent formulated especially for washing painted surfaces, shall be used. Oil and grease not removed by the washing operation may be removed by wiping with Paint Thinner. The Paint Thinner should then be washed off and the surface given a fresh water rinse. Allow the surface to dry thoroughly before applying any paint.

##### (C) BURNING OFF

Should the removal of old paint from wood

surfaces become necessary due to scaling, blistering, peeling, checking, cracking or excessively built-up thickness, it may be removed by burning. The technique is to blister the paint with a portable gasoline blow torch, without scorching the wood, and then to scrape it off with a hand scraper while it is hot and soft. Start at the bottom of the job and work toward the top. A good job of burning off will result in a surface reasonably free from scorching and the paint so completely removed that only a slight sandpaper rub will be necessary before painting.

When burning paint off an old building, care must be taken to prevent flames entering between cracks in the siding and igniting cobwebs, litter within the wall, or the framing members themselves. Always have a fire extinguisher handy in case of a fire.

Burning off should never be done in a closed compartment because the gases and fumes are toxic.

Note:

(a) When work is to be done by contract: If removal of old paint by burning is to be permitted, the contract specification shall specifically include a description of the method outlined above.

(b) When work is to be done by Coast Guard personnel: No burning off of old paint shall be done without the prior approval of the District Commander or the Commanding Officer of Headquarters Units.

#### (D) USE OF PAINT REMOVER

Paint remover may be used to advantage on furniture and on inside jobs where burning off cannot be accomplished. Apply the remover liberally with a full brush without brushing out any more than is necessary. Do not break the wax film which forms over the remover after it has been applied because this would allow the gases to escape without acting on the paint film. Due to the toxic nature of the volatiles in paint remover, adequate ventilation is necessary.

Let the remover stand until the old paint or varnish begins to blister or wrinkle. This takes from ten to twenty minutes depending upon the type and thickness of the old finish. Sometimes a second coat of remover will be necessary. After the old finish begins to wrinkle or

blister, lift it off with a broad putty knife or hand scraper. Apply another coat of remover and rub in the direction of the grain with steel wool to remove any last traces of the old finish. Wash the surface with Paint Thinner or alcohol to get rid of any wax or acids left by the remover.

Paint remover will work faster and better on horizontal surfaces. Doors and other pieces which can be moved should be placed in a horizontal position on a bench or sawhorses to facilitate the operation.

Wood surfaces to be varnished or lacquered will probably require some sanding to obtain a fine smooth surface and reveal the grain of the wood to best advantage. The surface must be dry before the application of the coating material.

#### (E) CALKING WOODEN BOATS

Prior to painting, hulls of wooden boats shall be thoroughly inspected and any defective calking shall be renewed. Before applying seam compound but after calking with oakum, the seam and oakum shall be saturated with Copper Naphthenate Wood Preservative. After the preservative has soaked into the wood and oakum, pay hull seams with Oil Type Calking Compound, applied with a putty knife. Finish seams with a hollow or concave surface to prevent forcing the compound out of the seam when the planking swells. Deck planking seams are sealed by paying with Marine Glue. In those cases when proprietary seam sealers are authorized, manufacturer's instructions shall be closely followed.

#### (F) CALKING CRACKS ON BUILDINGS

Calking material may be used to fill holes and cracks which are too large to be filled with putty or plastic wood. Cracks between ends of siding boards, which occur due to shrinkage of the lumber, may be filled with Plastic Calking Compound prior to painting. Some cracks such as those under blind stops on windows or doors, which exist when window casing is nailed over siding boards or shingles, may be filled by calking with oakum up to about  $\frac{1}{2}$  in. of the outer edge of the blind stop. The remainder of the crack should be filled with calking compound which can be smoothed off to present a neat

## 1-5-5

appearance. Split or loose boards should be replaced or railed securely. Calking compound should never be used as a substitute for adequate repairs.

### 1-5-5, PREPARATION OF MASONRY SURFACES

Masonry surfaces are prepared for painting by cleaning, repairing and sealing the surface. In some cases a pretreatment must be given the surface prior to paint application. These steps are discussed in greater detail in the following paragraphs.

#### (A) CLEANING THE SURFACE

The procedure for cleaning masonry surfaces for painting will depend upon the type of paint previously applied and the type of paint which is to be used. Specifically, oil paints and acrylic emulsion paints may be applied over old, firmly adhering, non-chalky coatings of oil paint or cement-water paint. Rubber solution paints require the complete removal of old coatings of oil paint since the solvents in rubber solution paint will lift undercoats of oil paint.

In cases where new paint is not compatible with old coatings or where the old coating is flaking and scaling, complete removal of the old coating will be necessary. This can be accomplished by scraping and wirebrushing. Sandblasting is the most effective method if equipment is available.

Where new and old paints are compatible and the old coating is in good condition, surface preparation will consist of removing dust, dirt, efflorescence, oil and grease. Dust and dirt can be removed by wirebrushing. All old paint should be lightly wirebrushed to make the surface uniform. Oil and grease can be effectively removed by washing with Paint Thinner followed by soap and water and a fresh water rinse.

#### (B) REPAIR OF MASONRY SURFACES

After the surface has been thoroughly cleaned, loose mortar between masonry courses shall be chipped and picked out, and the joint brushed thoroughly to remove all dust and loose particles. The cleaned surface shall be dampened before new mortar is applied to prevent absorption of water from the mixture.

To make repairs, a mixture of 1 part cement to 2½ parts sand, or 1 cement to 3 sand is recommended in ordinary cases. However, a 1:2 mixture is recommended for damp basements or masonry exposed to very moist conditions. A 1:2 mixture represents 1 part Portland cement to 2 parts sand, measured by volume. The proportion to be used will depend entirely upon conditions, a larger proportion of cement being necessary in cases where excessive moisture prevails.

Enough water should be used to make a fairly dry mortar about the consistency of putty. It should be thoroughly mixed and worked to insure best results. In filling cracks, the mortar should be used like calking material, that is, it should be well tamped to form a complete bond. When the crack has been tightly packed the surface should be smoothed with a trowel. In pointing up joints in masonry, the mortar may be applied with a trowel and the surface finished to conform to the old mortar.

After the material has hardened, the new work should be kept wet for several days to increase the strength of the mortar. If work has been done on outside walls, they should be covered by tarpaulins to protect them from direct exposure to the sun and drying winds.

#### (C) REPAIR OF PLASTER SURFACES

Cracks, holes and other defects in plaster surfaces must be repaired prior to repainting if a good finished job is to be achieved.

Small cracks, holes and indentations can easily be repaired with spackling compound. This material is applied with a putty knife or, in the case of hairline cracks, merely rubbed in with the fingers. Spackling compound is available through GSA under Stock Number 5610-550-6137.

Large holes in plaster surfaces or areas where large sections of plaster have fallen out must be replastered. Remove all loose plaster around the edges of holes. Edges of firmly adhering plaster should be dovetailed so that the hole is wider next to the lath than on the surface. This will provide an anchor for the new patch material. Old, firmly adhering plaster adjacent to the hole should be wetted to prevent the absorption of water from the new plaster. Apply new plaster described as Calcined

Gypsum (Plaster of Paris) Retarded. This material sets in 40 minutes. Therefore, the job must be done as quickly as is consistent with good workmanship. Follow directions for mixing and applying which are printed on containers. The surface should be kept damp for about 24 hours after the new plaster has set.

After the new plaster has dried about 7 days, sandpaper to smoothness. The work should be scheduled to allow the new plaster to age as long as possible, allowing 2 weeks at least prior to application of Latex Emulsion Paint, and 1 month before application of Interior Gloss Enamel. Longer aging periods are recommended if at all practicable.

#### (D) SEALING THE SURFACE

New plaster and porous masonry must be sealed to prevent suction spots and saponification (the action of alkalies in the masonry on oils in the paint). Modern sealers are a combination of sealer and primer and are listed in Chapter 4. However, in the case of oil paints, where mortar-filled joints are new, a minimum of 1 month drying time should elapse before the application of the paint.

On old surfaces where minor repairs are made prior to painting and 1 month drying time is impractical, calking compound rather than cement mortar should be used as a crack filler.

#### (E) PRETREATMENT OF MASONRY SURFACES

Emulsion paints and rubber solution paints may be applied on dry or damp masonry. In very hot weather it is advisable to dampen the surface prior to the application of emulsion paints.

#### 1-5-6, CLEANING PAINTED SURFACES

Painted surfaces to be cleaned shall be washed with Paint Cleaner, a synthetic detergent, which is listed in Chapter 4. Where Paint Cleaner is not readily available, household detergents such as Soilax, Fab, Tide or equal may be used.

The use of free alkalies is extremely harmful to most organic coatings. These alkalies

attack the film, break it down and cause early failure. The use of lye, trisodium phosphate or other strong alkali solutions for the purpose of washing painted surfaces is therefore prohibited.

It will be found that a weak mixture of Paint Cleaner or equal synthetic detergent is entirely adequate for washing paint work and only such cleaners are authorized.

Vinyl Paints and epoxy enamels are an exception to the above, due to their exceptional alkali and abrasion resistance and may be scrubbed with the more alkaline cleaners.

#### 1-5-7, ABRASIVE PAPER GRADING

Abrasive paper is graded by two systems, i.e., grit number symbols and commercial grit size.

The grit number symbol system (1, 1/0, 6/0, etc.) is based on the size of grit that will pass through a screen of a given mesh. The grit symbol number corresponds to the gauge of the screen. Thus, a number 3/0 abrasive paper contains grit which will pass through a number 3 gauge screen. This was the earliest system developed but is rapidly being replaced by the commercial grit size system.

The commercial grit size system is based on the number of pieces of grit of uniform size that can be placed in a single layer in an area of one square inch. The comparative grading chart on the next page will provide information for relative comparisons. Products of individual manufacturers may vary slightly.

#### 1-5-8, SAFETY PRECAUTIONS IN ABRASIVE CLEANING

##### (A) PROTECTIVE CLOTHING

Abrasive cleaning, conducted mostly at shore units, involves a number of hazards. The chief dangers to personnel are bodily contact with the abrasive stream, surges in the air pressure lines, the breathing of abrasive materials, explosion, electric shock.

Protective equipment and clothing for abrasive blasting and cleaning must be worn. Mandatory equipment consists of hoods, masks or air helmets, steel-toe boots or shoes, rubber

## ABRASIVE PAPER GRADING CHART

Grade	Com'l		Grit Number Symbol			
	Grit Size	Silicon Carbide	Aluminum Oxide	Garnet	Flint*	Emery*
Very Fine	600	12/0	—	—	—	—
	500	11/0	11/0	—	—	—
	400	10/0	10/0	—	—	—
	360	—	—	—	—	—
	320	9/0	9/0	—	7/0	—
	280	8/0	8/0	8/0	6/0	—
	240	7/0	7/0	7/0	5/0	—
Fine	220	6/0	6/0	6/0	4/0	—
	—	—	—	—	3/0	—
	180	5/0	5/0	5/0	—	3/0
	150	4/0	4/0	4/0	2/0	2/0
	120	3/0	3/0	3/0	—	1/0
	—	—	—	—	1/0	—
	100	2/0	2/0	2/0	—	—
Medium	—	—	—	—	1/2	1/2
	80	1/0	1/0	1/0	—	1
	—	—	—	—	1	—
	60	1/2	1/2	1/2	—	1 1/2
	50	1	1	1	1 1/2	2
	—	—	—	—	2	2 1/2
	40	1 1/2	1 1/2	1 1/2	—	—
Coarse	—	—	—	—	2 1/2	—
	36	2	2	2	—	3
	30	2 1/2	2 1/2	2 1/2	3	—
	24	3	3	3	3 1/2	—
	20	3 1/2	3 1/2	3 1/2	—	—
Very Coarse	16	4	4	—	—	—
	12	4 1/2	4 1/2	—	—	—

\*Commercial Grit Size not applicable.

or leather gauntlets, durable clothing, safety helmets, goggles. For proper equipment consult FSC Groups 42 and 84 of current catalogs.

#### (B) SAFETY RULES FOR DRYBLAST

Use sandblast or abrasive hose equipment constructed with activated carbon to prevent electric shock to the operator. Be sure hose is kept dry when stored.

When hose is in use, be sure it is kept in a straight or widely arced curve. Avoid sharp bends which may cause rapid wear and blow-out.

Never point a nozzle at any part of the body, including your own. Make absolutely sure that

masks, hoods or air helmets will not admit dust. The danger of silicosis must be avoided. Air-fed respirators or hoods will not offer full protection against dust and fumes unless a separate air purifier or a special ring-free compressor is used to assure pure air.

#### (C) SAFETY RULES FOR WETBLAST

An automatic deadman safety control at the nozzle is imperative. Water hose must be of proper quality to suit the equipment and must be tested to withstand 4 times the regular working pressure. Fittings must also be tested to withstand 4 times normal pressure. By-pass



valves must be equipped with safety relief valves.

The nozzle must never be aimed at any person. Care should be taken to avoid breakage or damage to surfaces and materials such as glass, wood, thin metal, piping, cable, machinery, etc.

High pressure hose must be firmly secured near the operator—not more than 10 ft. away. The operator should wear safety rubber gloves, safety rubber suit, safety shoes, helmet, goggles, to afford full protection to the face, body, arms, legs, hands, feet. Face shields of heavy plastic are necessary for high pressure blasting; safety goggles may be worn when cleaning is done at low pressure.



Protective clothing for abrasive cleaning.



## SECTION 1-6 PAINT MIXING

All paints should be vigorously and thoroughly mixed before application. Settled paint in a can contains too much oil or vehicle at the top, while the pigment has settled at the bottom. Paint mixing is best achieved by power shakers or power mixers. Figure 1 shows a power shaker. This shakes the can vigorously while it is closed and effects a thorough blending of pigment and vehicle. Such items are expensive and are warranted only at large paint volume establishments. Figure 2 shows a portable electric paint mixer which stirs the paint. For this type, and for less intricate mixers, the can of paint to be mixed should be open. Lids should be removed in such a way as to not deform the lid so it can be used to reclose the can. This is to

be done by using a flat tool such as a screw driver to pry up the lid only enough to loosen it. Do this all around the lid as in Figure 3



Fig. 2. Portable electric paint mixer.



Fig. 1. Power paint shaker.



Fig. 3. Correct way to open can.

and no damage will be done to either can or lid.

Satisfactory paint mixing can be achieved by using a Paint Mixing Attachment, Stock number GSA5130-310-2140. This consists of a dual propeller shaft which can be attached to a portable power drill and inserted in paint cans for thorough mixing. However, due to the danger of sparks from electrical equipment igniting the paint fumes, only such electric drills as are certified non-sparking or are totally enclosed shall be used inside compartments and other enclosed or poorly ventilated areas. If such equipment is not available, use mechanical paint shakers, pneumatic drills, or stir by hand. See Figure 4.

When power shakers or mixers are not available, it is necessary to mix the paint by hand. To do this, pour off most of the clear liquid at the top of the container as in Figure 5 and mix the remainder thoroughly with a broad paddle.

Add a small amount of the clear liquid and stir well, using a figure 8 motion with the paddle. Repeat the process, adding a small amount of liquid at a time, until all of the liquid has been added and the paint is



Fig. 4. Paint mixing attachment for electric hand drill.



Fig. 5. Pouring off the top liquid.

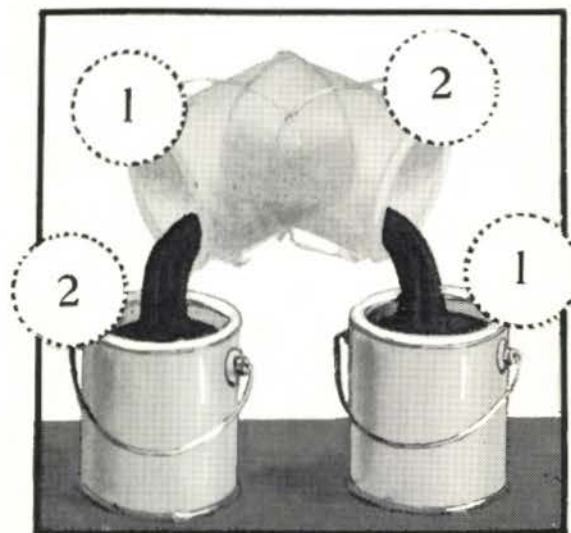

Fig. 6. The steps in "boxing."

uniform. Next, "box" the paint. Boxing is performed by pouring the paint back and forth between two containers as in Figure 6. This insures a homogenous mixture.

After the paint has been thoroughly mixed, all particles of pigment, dirt and skin should be removed by straining through a wire screen or cheesecloth. Any paint left over from a job should be strained before storing.

Turning paint containers, which are in storage, "bottoms up" periodically (at least once every 90 days) will greatly reduce the labor involved in mixing paint. See Article 1-4-1.



## SECTION 1-7

### BRUSH PAINTING

Many types of brushes are carried in stock listed under the letters FSC Class 8020 and are generally available from General Services Administration. Each brush is made for a particular purpose and, for best results from brush painting, the right brush for the job must be used. Quality brushes are hand made and are costly. Properly used, they will give good results and have a long life. In general the care of brushes is not accorded the attention it is due. The following paragraphs describe brush constructions, brush types, use of brushes and care of brushes.

#### 1-7-1, BRUSH CONSTRUCTION

The quality of a paint brush is dependent upon five factors:

(a) The texture of the bristle which determines the paint spreading properties of the brush. Textures refer to the blending of stiff and soft bristles in the right proportion.

(b) The weight content of the bristles which determines the degree of paint retention. The longer the bristle the more the weight in the brush and the more costly it becomes.

(c) The solidity of the bristle which determines the degree of paint absorption. Proper solidity is the result of the right proportion of long and short bristles.

(d) The setting of the bristle which determines the degree of shedding of the bristle.

(e) The construction of the brush which determines the smoothness of the paint application.

From examination of the above factors it can be seen that the quality of the bristle determines, to a large extent, the quality of

the brush. Both natural and synthetic bristles are used for paint brushes. Brushes with synthetic bristles should have "flag" ends such as nylon bristles to assure smooth application of paint.

Natural bristles are thick at the butt end and they taper to the flag or splayed end. Synthetic bristles like nylon are splayed during process of manufacture. Bristles of horse hair do not taper and have no flag ends. See Figure 7.

In the manufacturing operation, bristles are sorted into bundles. Butt ends are placed in the same direction and each bundle receives the proper proportion of soft and hard bristles, while the curvature of the bristles is made to lie in the same direction.

The component parts of a brush are generally as follows:

The handle is made of hardwood or plastic and is shaped to fit the hand for the specific type of work the brush is designed to perform.



Fig. 7. Comparison of hog bristle, nylon bristle and horse hair.

The setting of the handle holds the bristles in the proper formation.

The ferrule, which is the connecting link between the handle and the stock (bristles), must be correctly and sturdily constructed so the handle and the stock will not come apart. Ferrules are generally made of steel, nickel, tinplate, or aluminum.

The stock is the working part of the brush and generally contains natural (hog) bristles or synthetic bristles. See Figure 8.

### 1-7-2, TYPES OF BRUSHES

#### (A) FLAT WALL BRUSHES

Flat brushes have a narrow rectangular cross section. They are available in widths from 2 in. to 5 in. and the bristles vary in length according to the width of the brush. The 4 in. brush with 4½ in. bristles is suitable for many kinds of general painting.

#### (B) OVAL AND SEMI-OVAL PAINT AND VARNISH BRUSHES

These brushes are available in 2½ in., 3 in., and 3½ in. sizes and are suitable for general painting and varnishing. The oval brush is mainly for heavy duty finishing work. The semi-oval is used for fine painting and varnishing work. These brushes pick up and retain more paint or varnish than the flat type brushes.

#### (C) FLAT VARNISH AND ENAMELING BRUSHES

These brushes come in sizes from 1½ in. to 4 in. They provide smooth application of varnish and enamel and are used for a wide variety of average purposes.

#### (D) FLAT AND ANGULAR SASH AND TRIM BRUSHES

These brushes are chiseled to provide the particular properties desired for trim and sash work. They come in sizes from 1 in. to 3 in. The angular brush is specifically designed for sash work and is suited for both paint and varnish.

#### (E) OVAL SASH BRUSHES

These brushes are sometimes preferred over the flat sash brushes and they come in sizes

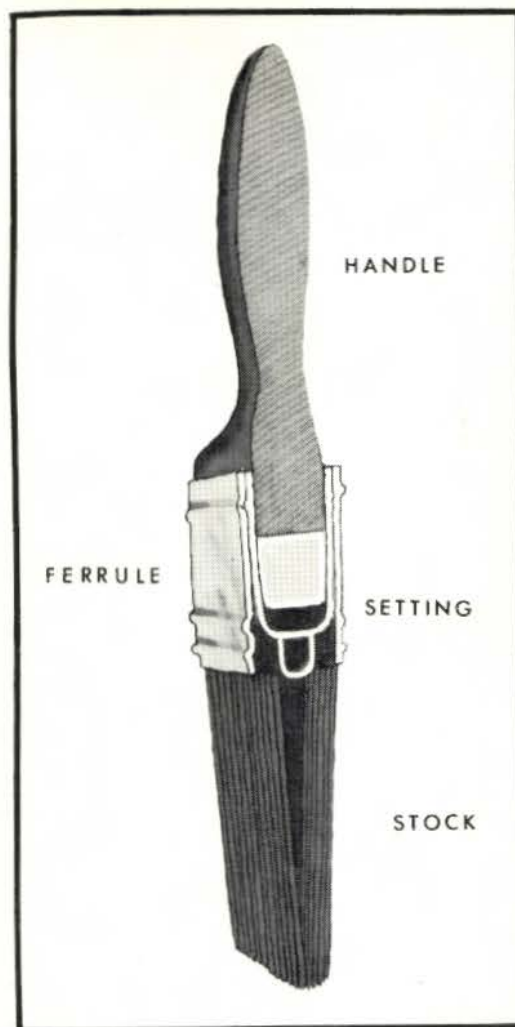

Fig. 8. Cross section of a quality paint brush.

from ½ in. to 1¾ in. They are good for paint application on moderately small surfaces, in corners and pockets and for other irregular surfaces.

#### (F) ARTIST'S MARKING AND LETTERING BRUSHES

These brushes are usually made of softer bristles and are used for extremely fine and lettering work. They are available in very small sizes such as 1/16 in. up to 1½ in.

#### (G) FLAT DUSTING BRUSHES

This type of brush is for brushing dirt and dust from surfaces to be painted. The duster is an essential and necessary part of the

### 1-7-3

painter's equipment. See Figure 9 for different types of brushes.

#### 1-7-3, BREAKING IN A NEW BRUSH

All new brushes, before being used, should be well shaken to remove loose particles and dust, and then carefully combed straight. A steel comb is recommended for this purpose. New brushes (particularly natural or hog bristle brushes) should be soaked in boiled linseed oil for about 48 hours. This will make the brush more flexible and easier to clean. When soaking in linseed oil, brushes should not rest on the bristles. This can be done by suspending brushes in a brush keeper (Figures 13, 14). After soaking, the surplus linseed oil should be pressed out. Then the bristles should be rinsed in Paint Thinner until all surplus oil is removed. The brush or brushes are now ready for use. Whenever a used clean brush has been stored in a dry condition for some time, it is advisable to soak it in linseed oil prior to use.

#### 1-7-4, BRUSHING TECHNIQUE

The life of any paint brush can be greatly extended and a better paint job will result from proper brush usage. Best results will be obtained by practicing good painting habits. Hold the brush as shown in Figure 10, firmly but lightly. The wrist and arm motions should be free and easy and not forced.

In holding the brush, the fingers should not go beyond the metal ferrule, or band, onto the bristles. This (fingers on bristles) may result in smearing and irritation to open cuts or sores. It will also tend to exert too much pressure on the center of the brush and wear it into a fish tail shape. See Figure 11.

A flat brush should not be used on its narrow edge. This practice will cause the bristles to spread, wear the corners down, and spoil the shape and efficiency of the brush. An oval brush should not be permitted to turn in the hand, but should be held firmly. Rotation of an oval brush will cause the bristles to wear into a pointed shape and become useless. Oversized brushes should not be poked or forced into areas too small for them. Flat wall and varnish brushes should

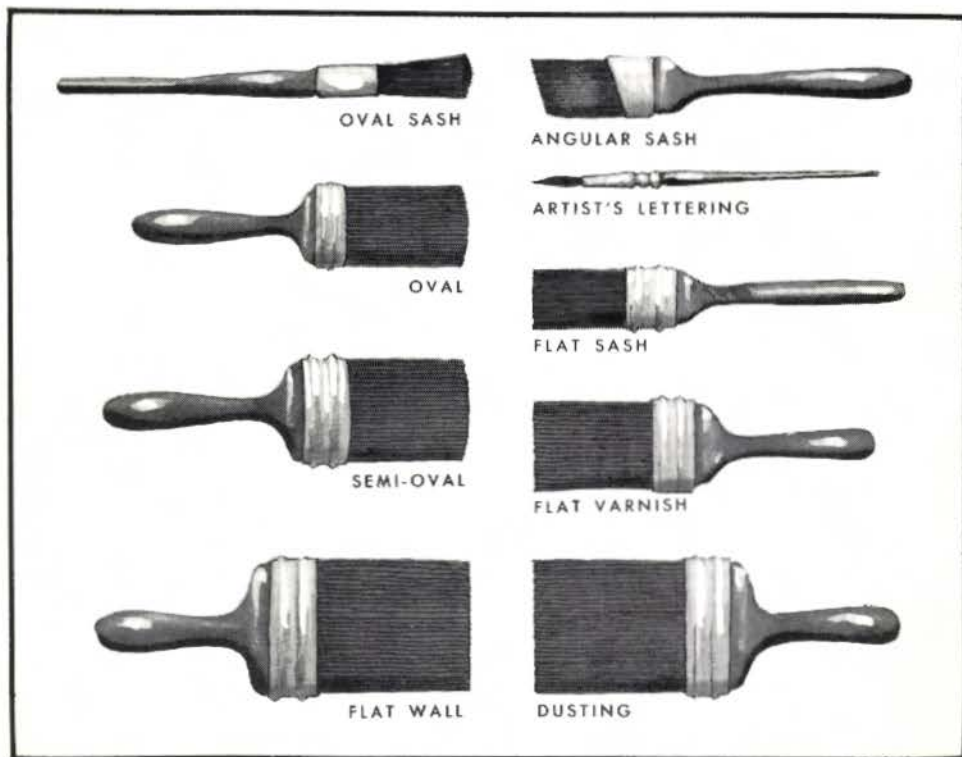

Fig. 9. Types of brushes.

not be jammed and squeezed into corners and around moldings and pipes. Smaller oval sash brushes should be employed for fitting into irregular and odd places.

Before starting to paint, work the paint well into the brush. This is done by holding a mixing paddle across the top of the paint container, dipping the brush into the paint, then wiping the flat sides of the brush clean across the edge of the paddle. Do this several times to insure filling the brush. Do not wipe the brush across the top edge of the paint can as its curved surface will distort the shape of the brush.

When painting a surface, dip only half the bristles into the paint. Tap the brush lightly against the inside of the can to remove excess paint, and then apply it to the surface. Any brush has a certain capacity, and if overfilled, paint will drip and run off around the work, particularly when working overhead.

Hold the brush at right angles to the surface being painted with the end of the brush just touching the surface. Lift it clear of the surface before starting the return stroke. If the brush is held obliquely and is not lifted, the finished job will be uneven and it will show lap spots giving a "daubed" appearance. Also a brush that is held at too great an angle will wear down at the ends. A properly used brush will wear down evenly all around.

Since paint films tend to draw thin on corners and edges, coat these areas before applying the overall coat. Apply the overall

coat immediately after this preliminary painting and without waiting for it to dry. Preliminary coatings of edges and corners are not counted as regular paint coats but are considered included in each total regular coat.

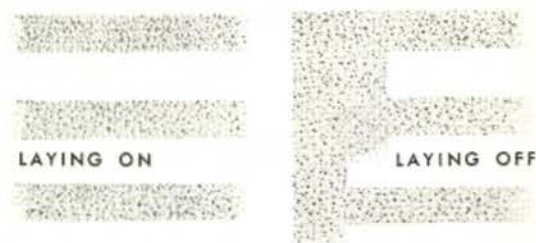

Fig. 12. Proper method of applying paint.

When applying the overall coat first "lay on", then "lay off". "Laying on" means applying the paint first in long horizontal strokes. "Laying off" means crossing the first stroke by working up and down. This method is shown in Figure 12 and insures even distribution and complete coverage with a minimum amount of paint. A good rule is to "lay on" the paint the shortest distance across the area and "lay off" the longest distance. When painting bulkheads, or any vertical surface, "lay on" in horizontal strokes and "lay off" vertically.

When two men work together on a bulkhead, the top stretch man should start at the bottom and "lay off" upward. This method results in the meeting of the wet edges which

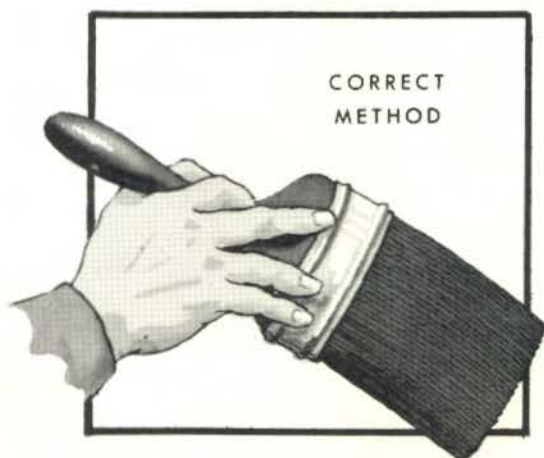

Fig. 10. Brush is held firmly as shown.

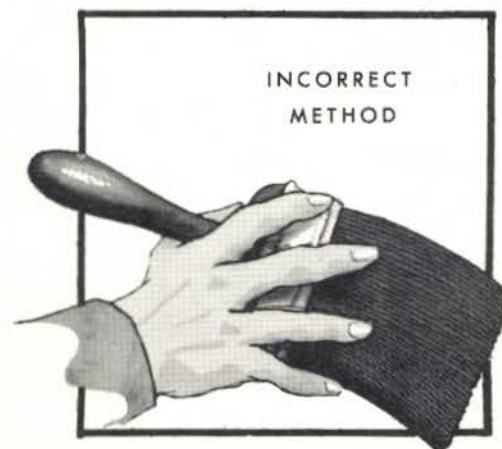

Fig. 11. Fingers are kept from bristles.

## 1-7-5

will blend into a perfect finish without showing where each man worked.

Bear in mind, however, that some of the fast drying paints will not permit "laying off," and in such cases the paint should be applied, spread rapidly, and left undisturbed.

To avoid brush marks when finishing up a square area, use strokes directed toward the last square finished, gradually lifting the brush near the end of the stroke while it is still in motion. Every time the brush touches the wet surface at the beginning of a stroke it leaves a mark. Therefore, always end up brushing backwards toward the area already painted.

Always paint overheads first, then bulkheads, then decks. All drippings should be wiped up immediately. Drops of paint are too thick to dry properly and when painted over become soft spots in the finished coat. They also look unsightly.

Wait until the first coat is thoroughly dry before applying a second. It cannot dry properly if covered too soon.

The paint in the can must be stirred frequently while painting. If the paint is left undisturbed the pigment will settle and you will be painting with oil or other vehicles (flowing and binding agent in paint).

Where practical, it is advisable to use brushes with nylon bristles in applying latex emulsion paints, as the nylon is immune to the damaging effects of the water and alkalis which are found in many latex paints.

### 1-7-5, CARE OF BRUSHES AFTER USE

Always clean a brush immediately after use. Use plenty of the thinner prescribed for the paint in which the brush was used. See that the thinner is worked well into the brush. Squeeze out as much thinner as possible and repeat the process two or three times. Finally, rinse in clean thinner. Do not throw away solvents and thinners used for cleaning brushes. Store them in closed containers for future brush cleaning. After setting in storage, paint particles will settle to the bottom and the clear portion of the liquid can be poured off and used for future brush cleaning.

If a brush is thoroughly cleaned and dried it should be stored suspended from the handle on a rack or wrapped in paper and stored flat.

However, if the brush is to be put to use again, perhaps within a few hours or a day, it may be stored temporarily as described below.

A simple brush keeper is shown in Figure 13. Drill a small hole through the brush handle and support the brush so that the ends of the bristles are allowed to soak in paint thinner. The keeper may be square or round, but it must have a tight lid to prevent evaporation and to avoid being a fire hazard.

A new type of "vapor action" paint brush conditioner is also useful. Figure 14 illustrates this item. With this type the brushes are held in a vapor solvent, not a liquid, such vaporization being accomplished by the use of a wick or line inside an airtight container. Vapor-conditioned brushes will remain soft and pliable with less danger of damage to bristles as a result of too much soaking in liquid.

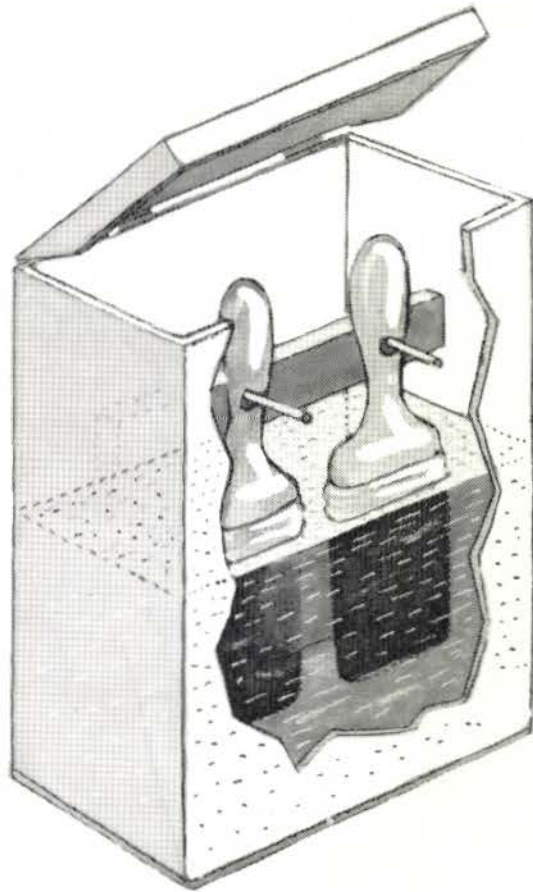

Fig. 13. Small brush keeper.



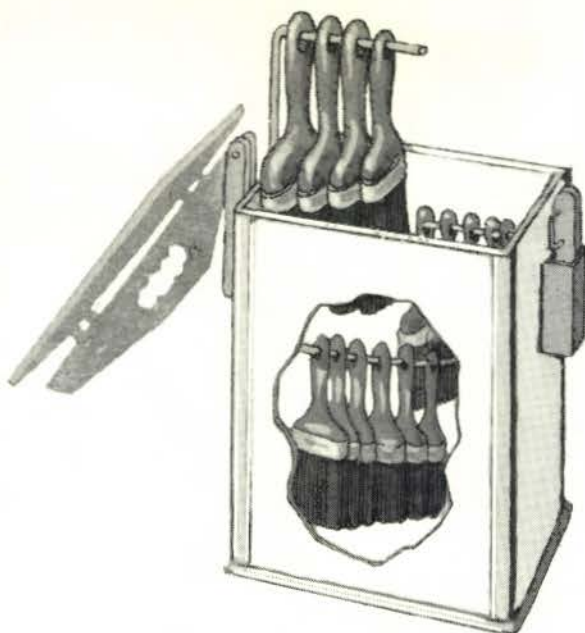

Fig. 14. Vapor brush conditioner.

A brush that has become hard with conventional type paint can be cleaned. Soak it in linseed oil for about 24 hours, then in paint thinner for the same period. A putty knife and wire brush will prove useful in scraping off loosened paint. Repeated soaking in paint thinner with scraping and cloth wiping should result in a workable brush. A brush that has been reclaimed cannot be expected to give the performance of a well cared for brush. However, it can be used for applying wood preservative, painting masonry, applying paint removers, and other rough jobs which would ruin a good brush.

Before starting to use a brush for painting, drain the liquid from it. Wipe the bristles clean and wash the brush in the paint thinner recommended for the paint to be used. You will find the bristles pliable and the brush easy to work with.

**CAUTION:** After using a brush, never leave it in an open can of paint or exposed to the air. Good brushes are expensive and hard to get. Clean them immediately after use and store them properly. Brushes used for epoxies should be cleaned immediately with special epoxy thinner, otherwise it is virtually impossible to clean the hardened residue remaining.

### 1-7-6, STRIPING

A craftsman-like job of striping with a brush is easy to accomplish by either of two methods. Both involve the use of masking tape which can be easily removed without damage to the surface.

The first method applies to surfaces which are finished and the striping is the only painting to be done. Mark the position and width of the stripe and apply masking tape to both sides of the stripe. The striping color is then brushed on. When the paint has set, remove the masking tape.

The second method applies to surfaces which are to receive a complete paint job. Mark the position of the stripe and apply the striping color overlapping the boundary marks slightly. After the striping color has dried, apply masking tape to the exact area of the stripe. Apply the finish coat to the entire area. When dry, remove the masking tape to expose the stripe.

When removing masking tape from a surface, pull it off somewhat diagonally and back upon itself. Do not pull the tape directly away from the surface at right angles.

### 1-7-7, SKIN IRRITATIONS DUE TO PAINTING

Paints, solvents and thinners are toxic to the skin. The degree of toxicity depends upon the person and the material being used. Persons not accustomed to continual contact with paint materials should wear clothing which protects their arms and should rub a protective cream into the hands and face before painting or paint mixing.

Mixing paint and working with paint thinner is hazardous in several categories. Splashes can cause eye injuries. Contact with the skin can cause dermatitis. Inhalation can cause respiratory injuries and damage other internal organs of the body as well. There is constant danger of fire and rigid precautions against fire should be enforced. (See Article 1-4-2.)

Many modern coatings and solvents are toxic to varying degrees. Excessive breathing of many solvents and paints may cause dizziness or nausea, drying or irritation of mucous membranes. In some cases there are allergic

### 1-7-7

reactions of the skin leading to rashes and swelling.

While many paints are irritating to the skin, the amines used in epoxy coatings and compounds may be particularly severe. Common reactions include swelling around the eyes or lips, rashes of the skin and adverse effects.

Because of all this, there must be full protection. While exposure in paint mixing may not be as great as in paint spraying,

none the less care should be taken. It is good practice to coat the hands with protective creams. Neoprene or rubber gloves should be worn. If mixing (or painting) is done indoors, goggles and respirators shall be required.

Care should be taken never to swallow paint. Strict adherence by painters to a system of good personal hygiene in washing with the proper type of soap or detergent, in eating and drinking, will practically eliminate the possibility of poisoning.

## SECTION 1-8

### ROLLER COATING



Rollers constitute another satisfactory method for paint application. New types of sleeves and covers, new sizes of equipment and other features have enabled rollers to perform a greater variety of paint application jobs. They still have limitations, to be sure, such as for small hard-to-get-at areas, and some irregular surfaces. However, where they can be used they offer a great advantage in speed.

#### 1-8-1, ROLLER CONSTRUCTION

The parts of a roller are:

(a) Handle. This is wood or plastic and has a variety of extension devices that can be attached to it. These can make hull painting easier, for work can be done from a raft or pier.

(b) Frame. The frame is usually  $\frac{1}{4}$  in. steel and is the axle for working parts of a roller.

(c) Cage. The tension type cage is most widely used today. The cages are easy to clean and they make cover changes a simple operation.

(d) Cover. The cover is the main working part of a roller because it applies the paint. There are several types and sizes. The standard size cover (for standard rollers) has a  $1\frac{1}{2}$  in. inside diameter. The main types and uses of covers are:

**Mohair.** Blends of wool, rayon, and mohair (angora goat's wool) are considered Mohair covers. This type cover is recommended for applying enamels to smooth surfaces.

**Lambswool.** This is one of the original materials employed for roller covers, and is widely used. It maintains its resilience and carries a greater amount of paint than many

other fabrics and is recommended in longer "nap" sizes for painting cyclone-type and other wire fences. "Nap" is the thickness of the cover. A general rule concerning nap in the selection of covers is the smoother the surface the shorter (thinner) the nap, and the rougher the surface the longer (thicker) the nap. Covers generally are available in  $\frac{1}{2}$  in.,  $\frac{3}{4}$  in., and  $1\frac{1}{4}$  in. nap thicknesses.

**Synthetic Covers.** Fibers, such as Dynel and Dacron are available for covers and can be used generally except for coatings which contain alcohols and ketones. A  $1\frac{1}{2}$  in. nap has been developed in a Dacron cover and can be used in exterior painting of chain link fence, cinder and cement block, and corrugated metal surfaces. Dynel is not recommended for cinder block painting.

All the above covers are applied to cores, which are made of plastic, wood, wire and

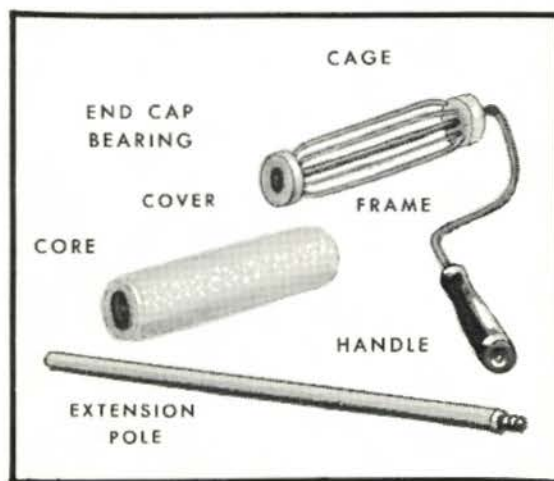

Fig. 15. Parts of a standard paint roller.

## 1-8-2

treated paper tubing. In quality covers (and cores) superior types of adhesives are used to bond the core and cover together so they remain firmly intact when cleaned in the most rugged solvents, including lacquer thinners. See Figure 15 for the parts of a standard roller.

### 1-8-2, TYPES OF ROLLERS

#### (A) STANDARD ROLLERS

The most widely used are the 7 in. and 9 in. standard rollers. The cage diameter dimension for both items is 1½ in. Many of these have handles with threaded holes for extension pole adaptation.

#### (B) TRIM ROLLERS

1½ in. and 3 in. (width) trim and edging rollers are available. They are used for window and door trim; with the smaller roller some molding can be covered.

#### (C) JUMBO ROLLERS

These 9 in. width rollers are similar to the standard roller except the cage has a 2¼ in. diameter. Jumbo roller covers can carry a greater amount of paint, and for the larger type jobs can cover more area per dip.

#### (D) HEAVY DUTY AND DOUBLE YOKE ROLLERS

There are 5/16 in. steel frame rollers with heavy duty tension cages for standard diameter covers. There are also 14 in. and 18 in. double yoke frames with long (54 in.) extension handles available. These are used for floor and large area painting. See Figure 16 for various types (other than standard) of rollers and covers.

### 1-8-3, DIP TYPE PAINT PANS

There are flat pans with a trough at one end into which paint is poured. The roller is dipped into the trough and rolled back and forth on the shallower section of the pan. In this manner the paint is evenly distributed throughout the cover. Also excess paint runs down to the deep end of the trough. Some pans have a hood over the deep end and brackets on the underside so the pan can hang from a ladder; paint will not spill out when the pan is in a vertical position. Another system is to attach a screen bucket grid inside a 5 gallon paint can. The roller can be dipped in the can and the excess removed by rolling back and forth on the screen grid. See Figure 17 for these types of pans and screen grid.

### 1-8-4, PAINT APPLICATION AND CARE OF ROLLERS

Roller coating is a simple procedure and the principles are much like brush painting. Paints can be "laid on" and "laid off" as with brushes to assure good even coverage. Also, always start on an unpainted area first and end up the last "roll" into the newest previously painted area. This will eliminate texture and lap marks of the roller. Rollers with extension poles can eliminate much work involved in rigging, staging and scaffolding. They are useful for painting hulls of vessels and other inaccessible areas such as high inside and outside walls.

Care should be taken in the roller painting of corners that the frame doesn't hit and mar freshly painted walls when applying paint on the adjacent wall. The smaller rollers should be used to prevent this.

Roller coaters should be cleaned immediately after use by washing thoroughly in the

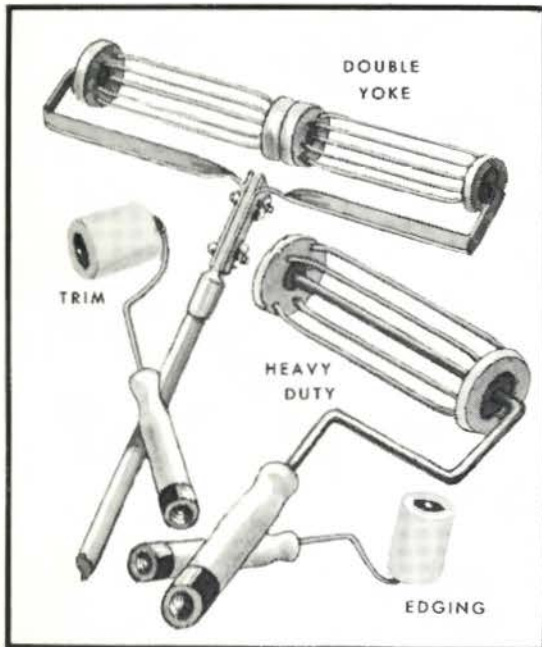

Fig. 16. Typical paint rollers.

thinner recommended for the paint which was used. After cleaning with thinner, the cover should be washed thoroughly with soap and water, rinsed and dried on the roller to prevent shrinkage. Combing lamb's wool and other thick nap covers while damp will prevent matting.

#### SPECIFIC PAINT ROLLERS AVAILABLE

Different types and sizes of rollers and separ-

ate covers are available from General Service Administration Class 8020, General Service Administration Catalog. The covers are of three types: Lamb's wool, Dynel and Mohair.

7 in. Paint Roller Applicator 8020-597-4760

9 in. Paint Roller Applicator 8020-551-6497

7 in. Replacement Cover (Dynel)

8020-291-0385

9 in. Replacement Cover (Dynel)

8020-291-0386

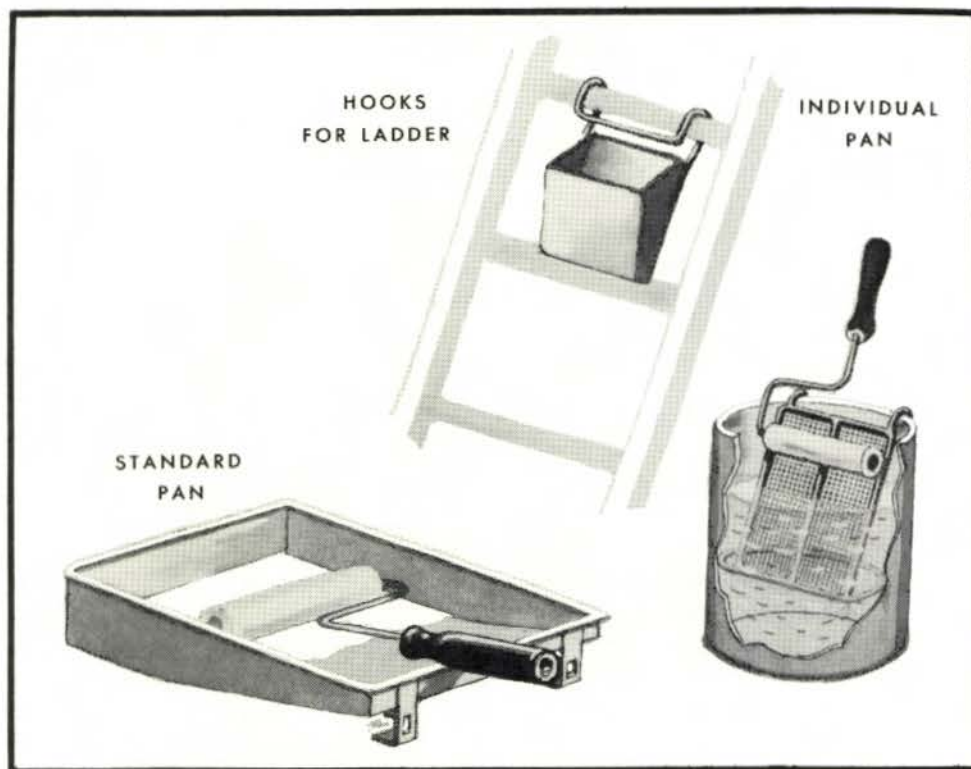

Fig. 17. Typical dip pans and screen grids for roller coating.



## SECTION 1-9

### SPRAY PAINTING

Spray painting is widely used throughout the Coast Guard. It can save many hours of labor as compared to brush painting. Spray application is particularly well adapted to painting overheads and areas where a large number of interferences are encountered, such as on vessels.

#### 1-9-1, TYPES OF SPRAY EQUIPMENT

There are three primary types of spraying equipment. While they are similar, each type has its own characteristic advantages. Certain kinds of jobs are best accomplished by one type and other jobs by another. Factors of speed, quality of finish, ease and flexibility of use, paint material characteristics and similar elements all have direct bearing on which system is best for the job. Following are the three types of brief explanations of their natures and advantages.

##### (A) CONVENTIONAL SPRAY

This is the most commonly used type of spray equipment. It employs compressed air

to atomize the paint at the nozzle of the gun and to feed the paint under pressure from the supply tank, pump, or cup to the gun nozzle. This type is simple and versatile. Many improvements over the past several years of its development have contributed to refinements of guns, nozzles, and regulating devices for practically every conceivable type of coating material and painting problem. Conventional spray is the basic system allowing the most diversity and, therefore, is a good all around method. Figure 18 shows a conventional spray system.

##### (B) HOT SPRAY

This method is primarily a modified form of conventional spray. It uses the same equipment as conventional units with one major addition which is a heating unit that heats the paint. This unit offers several benefits under certain operational conditions. With most organic paints which become less viscous at elevated temperatures, the hot spray system can apply higher solid content paints. This in turn produces greater film thickness

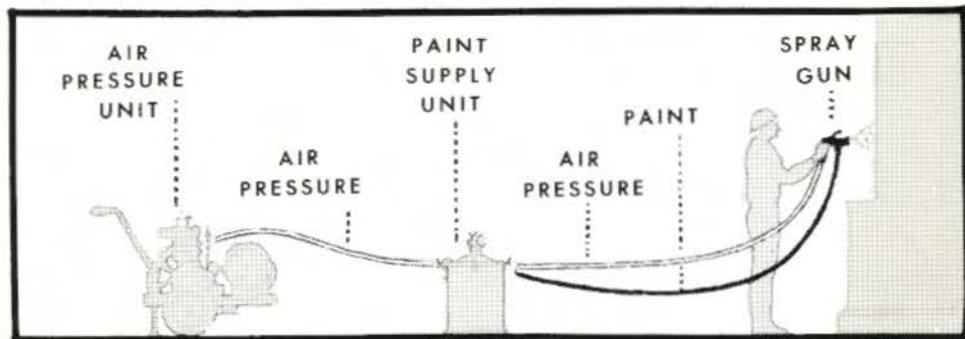

Fig. 18. Conventional spray system.

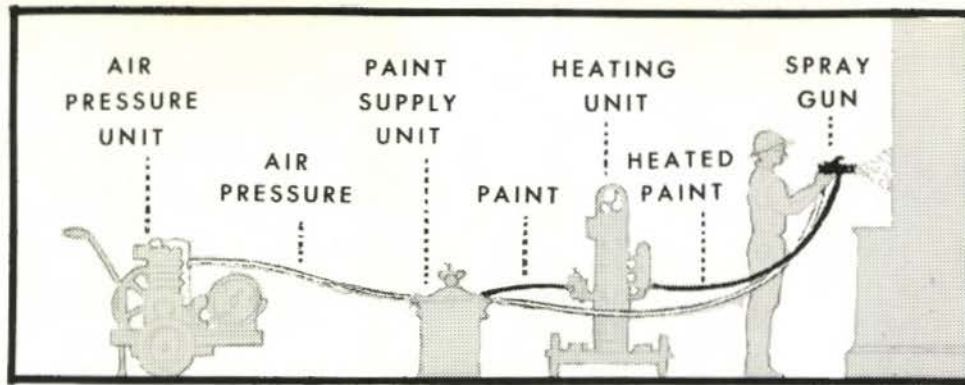

Fig. 19. Hot spray system.

and reduces the number of coats to achieve the desired film thickness. With heated paint, better atomization (spraying) is accomplished with lower air pressure (than conventional air pressure), and at the same time overspray is reduced. Hot spray also permits painting when atmospheric temperatures are well below the 70° F. optimum for conventional spray. Figure 19 shows a hot spray system.

#### (C) AIRLESS SPRAY

In an airless system the spray is created by the forcing of paint through a restricted orifice at very high pressure. Atomization of the paint occurs without the use of air jets (as with conventional and hot spray). Liquid pressures of 1900 p.s.i. and higher are developed in special air-operated high pressure pumps, and the paint under this high pressure is delivered to the gun through a single hose line. The airless system provides a very rapid means of covering large areas and surfaces with wide angle spray without overspray mist

or rebound. The single small diameter hose line makes gun handling easy. Airless spray produces a full jet pattern for quick film build and is good for dried, absorbent and weathered surfaces. Figure 20 shows a diagram of the airless system.

#### 1-9-2, PARTS OF CONVENTIONAL SPRAY SYSTEMS

The following paragraphs and diagrams generally refer to conventional spraying equipment since the hot spray system simply adds heated paint to the conventional method, and airless, as described above, substitutes high paint pressure for air pressure in the gun. Most methods described for spray painting techniques and procedures would apply to all three types of systems.

A spray painting outfit consists of an Air Compressor to supply air power to the Spray Gun; an Air Transformer which filters out dust and dirt, condenses moisture and oil,

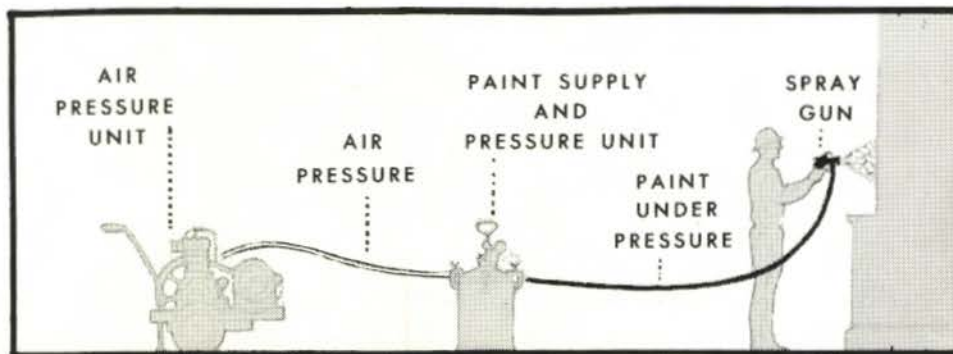

Fig. 20. Airless spray system.

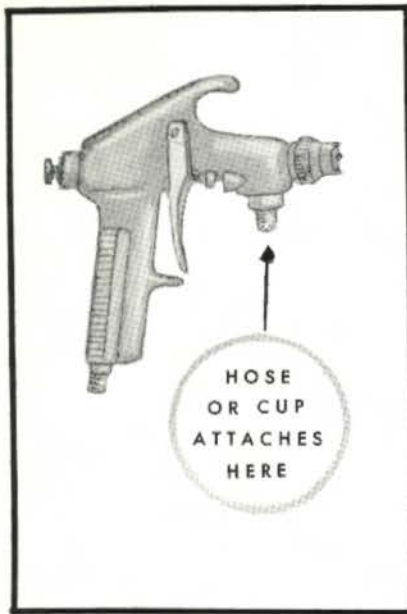

Fig. 21. Separate or tank container type.

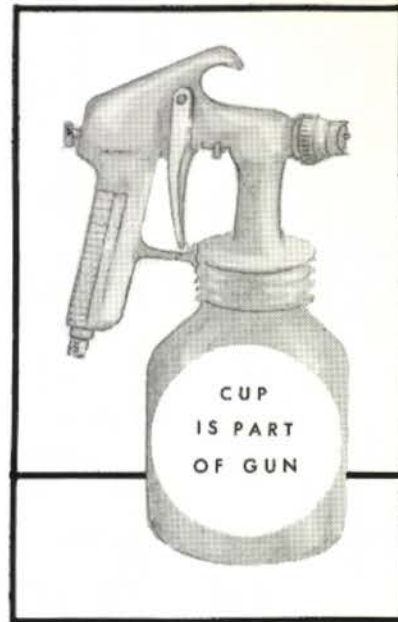

Fig. 22. Attached or cup container type.

and regulates the flow of air; Hoses to conduct both air and paint to the Spray Gun; a Paint Container, either Cup or Tank, to contain the material being applied and meter it out to the spray gun; and finally the Spray Gun itself.

Spray equipment is commonly classified according to the type of container used, i.e., it is usually called a Tank Type or a Cup Type. This classification is an indication of the size job the equipment is capable of doing,

but it gives no information about the Spray Gun which is, after all, the heart of the spraying operation, and therefore much more important than the container. See Figures 21 and 22.

Three factors determine the type of spray gun.

(a) Method of air supply pressure regulation, i.e., bleeder and non-bleeder.

(b) Method of atomization, i.e., internal mix or external mix.



Fig. 23. Bleeder type.

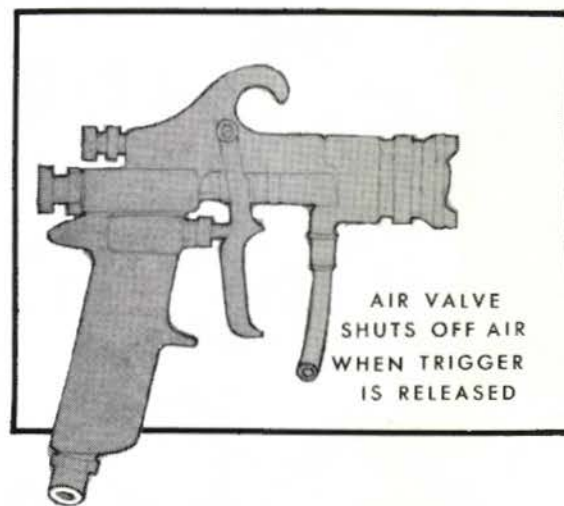

Fig. 24. Non-bleeder type.



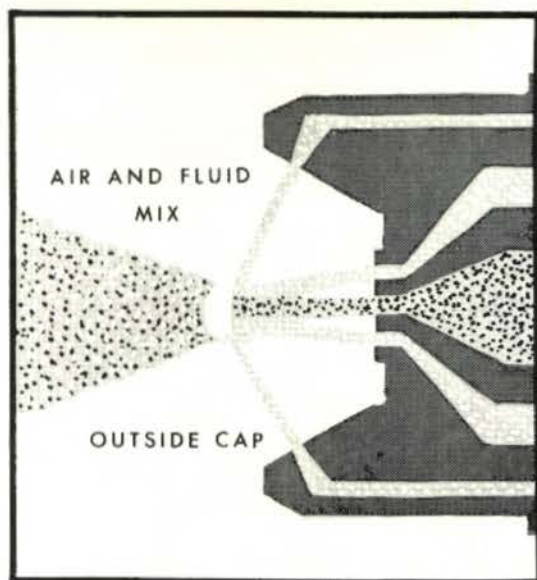

Fig. 25. External mix air cap.

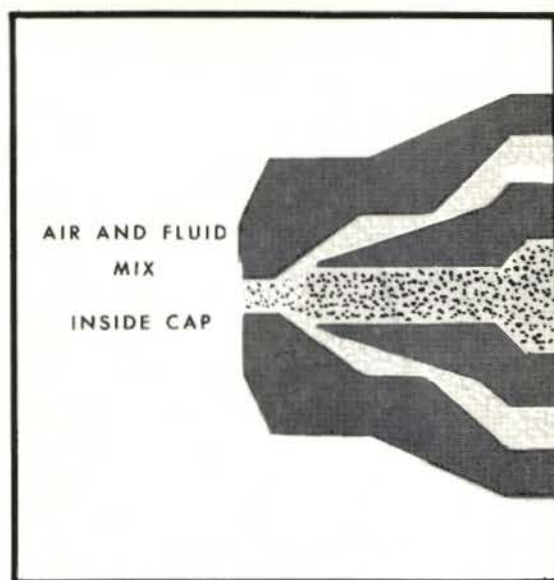

Fig. 26. Internal mix air cap.

(c) Method of fluid feed, i.e., suction or pressure.

#### (A) BLEEDER AND NON-BLEEDER GUNS

Bleeder guns (Figure 23) allow air to leak from some part of the gun when the Trigger is released. They are used with air compressing outfits having no pressure controlling device to eliminate excessive pressure build-up in the hose. Bleeder guns can also be used with compressor outfits having controlling devices. Non-bleeder guns (Figure 24) must always be used with air compressing outfits which have pressure controlling devices, since releasing the Trigger shuts off the flow of air and liquid completely. Air pressure is usually automatically regulated either by the compressor or by a pressure regulator on the tank.

#### (B) INTERNAL AND EXTERNAL MIX GUNS

External mix guns (Figure 25) mix the air and material outside the air cap.

Internal mix guns (Figure 26) mix the air and material inside the air cap.

#### (C) PRESSURE AND SUCTION FEED GUNS

A Pressure Fed Gun (Figure 27) uses air pressure on the fluid to force it from the

container to the gun. Either cup or tank containers are used. Pressure feed gives better results than suction feed since better control of air to fluid ratio can be obtained through separate controls for each. Either external mix or internal mix guns may be used with pressure feed and they may be of the bleeder or non-bleeder type depending upon whether pressure control is available.

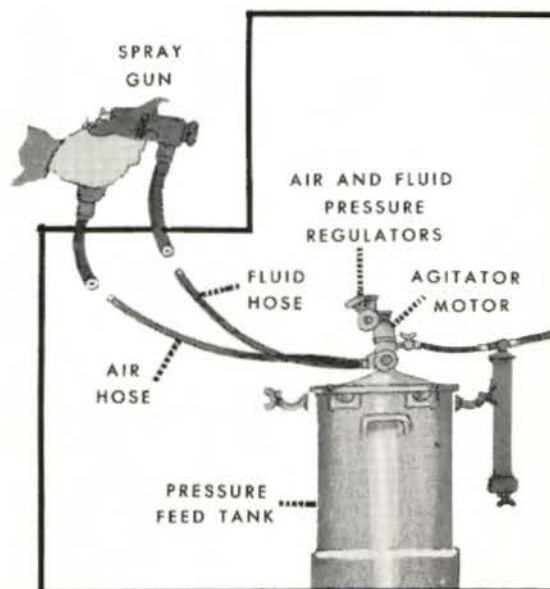

Fig. 27. Pressure fed gun.

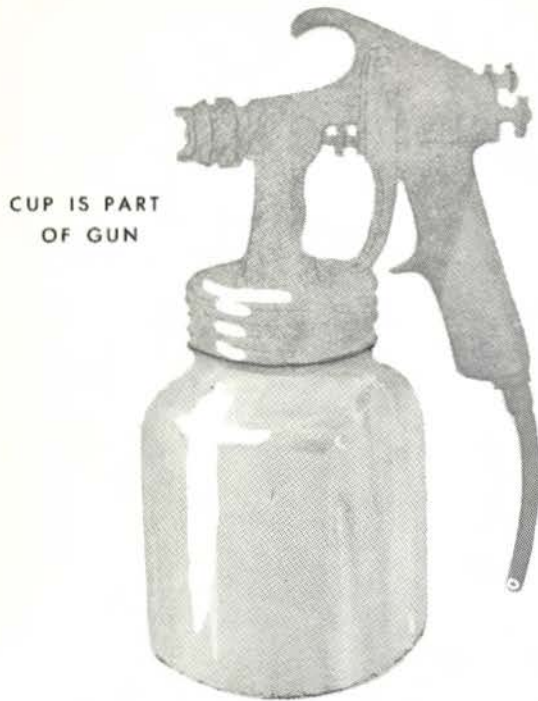

Fig. 28. Suction feed type.

Suction fed guns create a vacuum that pulls the paint from the container into the gun. The vacuum is created by the fluid tip pro-

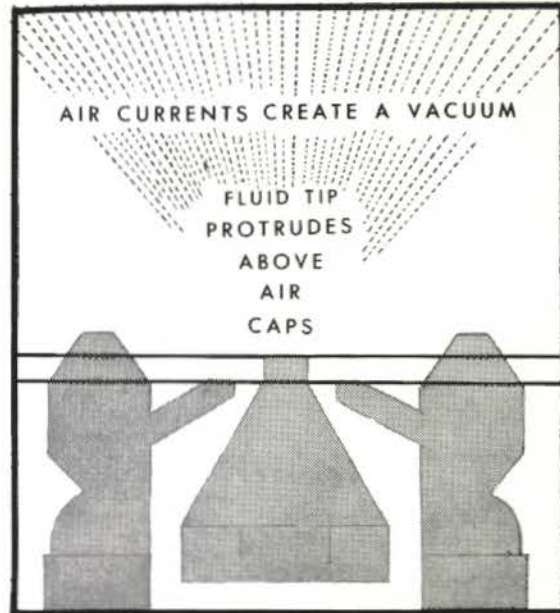

Fig. 29. Suction feed cap.

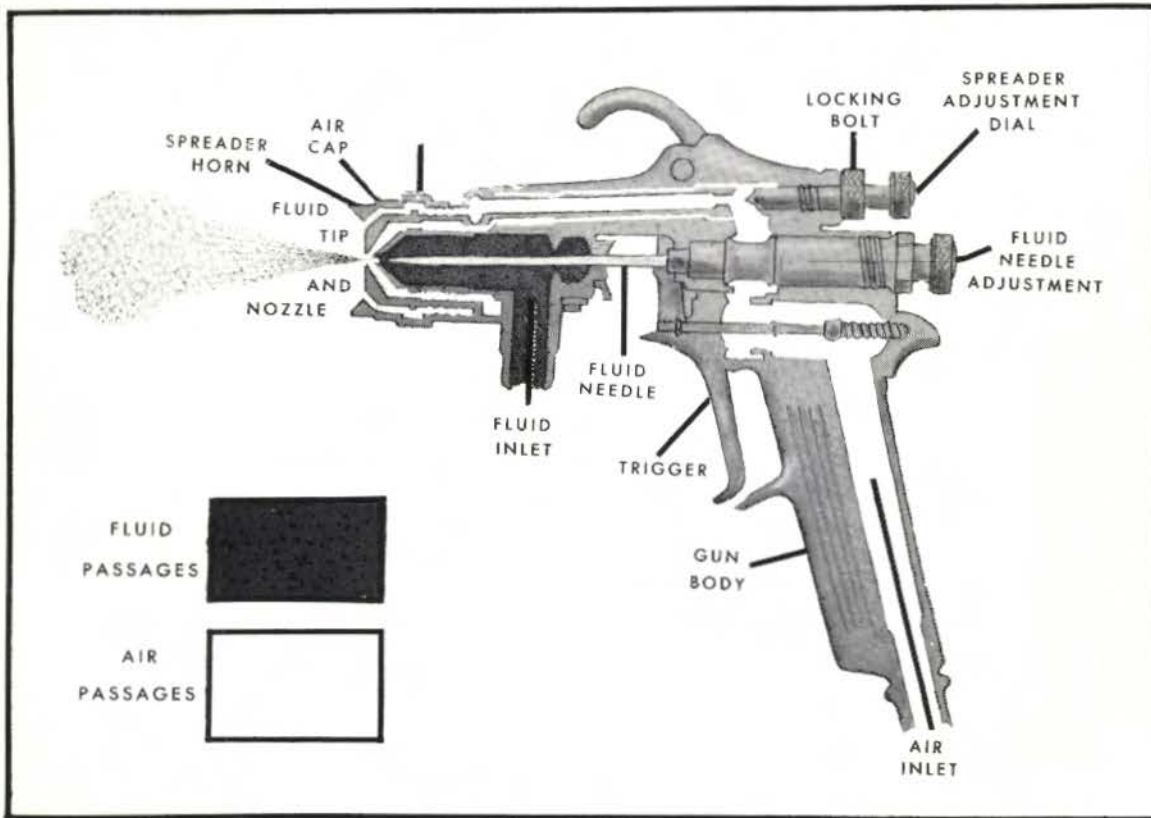

Fig. 30. Gun body assembly.

truding beyond the air cap on external mix guns. The air flow (past the tip) causes the vacuum and draws the paint into the gun. Suction fed containers (Figures 28 and 29) are usually attached to the gun and, due to weight, are necessarily small, usually one quart or less and are used for small paint jobs.

Paint spray equipment is available to the Coast Guard as listed in Section 4-9.

### 1-9-3, THE CONVENTIONAL PAINT SPRAY GUN

The principal parts of the Spray Gun used with both types of the aforementioned equipment are shown in Figure 30. Both the Air Valve and Fluid Valve are opened and closed by the pull and release of the Trigger. The fluid Needle Adjustment is a valve which allows more or less material through the Nozzle by controlling the movement of the Fluid Needle. The Spreader Adjustment Valve controls the air to the Spreader Horn Holes. This valve is equipped with a dial for facilitating settings. The Locking Bolt locks the removable Spray Head and Gun Body together. Various spray patterns are produced by changing the dial settings. See Figures 31 and 32.

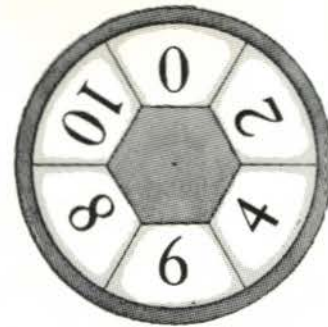

Fig. 31. Spreader adjustment dial.

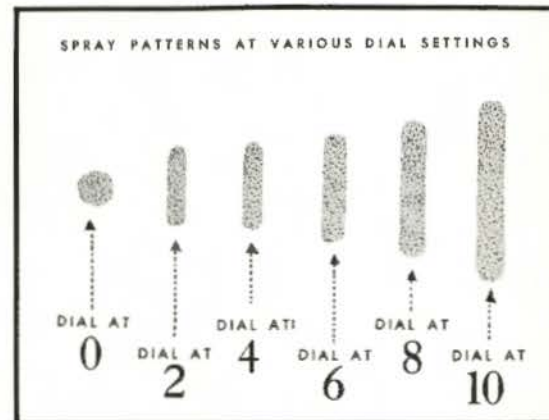

Fig. 32. Patterns at various dial settings.

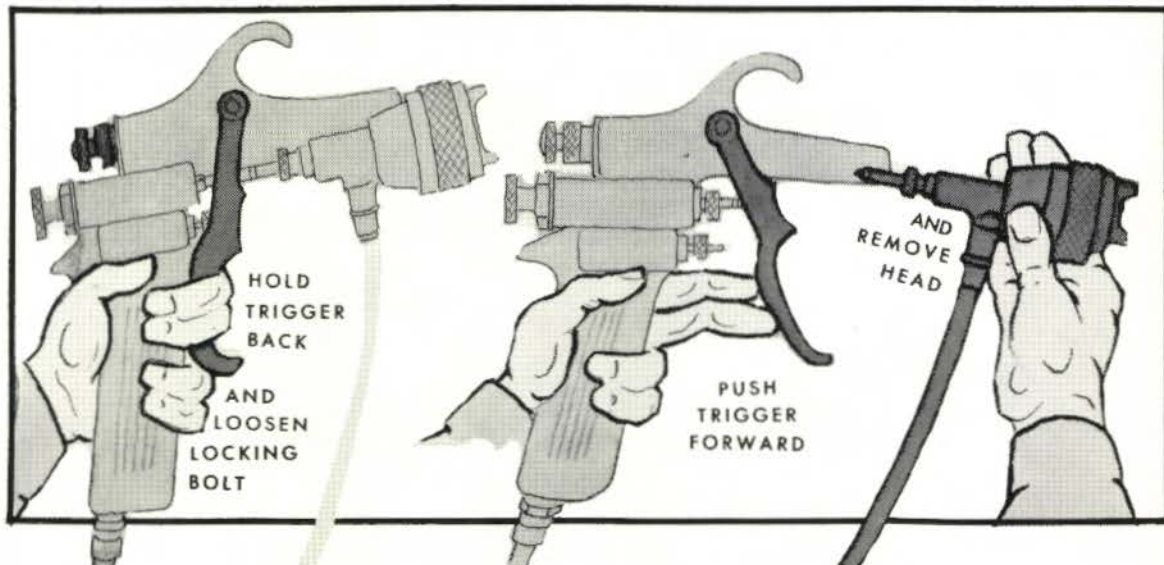

Fig. 33. Method of removing spray head from spray gun body.

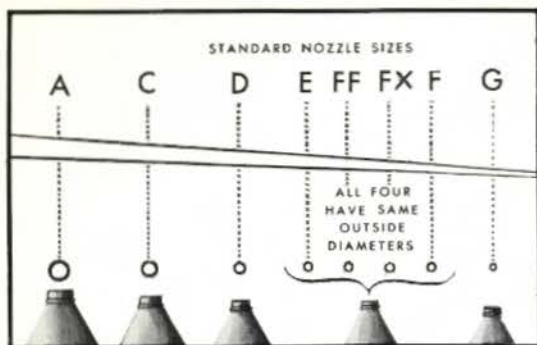

Fig. 34. Fluid tips come in different sizes.

The removable Spray Head Assembly consists of the Air Cap, Fluid Tip, Fluid Needle and Spray Head Barrel. It can be quickly removed from the Spray Gun Body (Figure 33). The principal advantages of removable spray heads are:

(a) Quick change from one material or color to another. One Spray Gun Body with several Heads will answer the purpose of what otherwise may require several guns.

(b) Ease of cleaning. The removable Spray Head is the only part of the gun which comes in contact with spraying material.

(c) In case of damage to front of gun, new Gun Body is not required.

(d) An extra Spray Head can be substituted for one being repaired or cleaned.

The Air Cap is that part at the front of the gun which directs the air into the material stream, atomizing the material and forming it into a suitable spray pattern. All Air Caps are of the Internal Mix or External Mix Types (Figures 25, 26) and may differ for suction fed guns (See Figure 29). The Fluid Needle is actuated by the Trigger and meters the fluid through the Fluid Tip into the air stream. The amount of movement of the Fluid Needle is controlled by the Fluid Needle Adjustment. When the Trigger is released the Fluid Needle cuts off the fluid flow. The Fluid Tip fits inside the Air Cap. It meters and directs the material into the air stream. It provides a self-aligning slot for the Air Cap and equalizes the air leaving the center orifice of the cap. The term "Nozzle" refers to the opening in the Fluid Tip. Nozzle sizes are shown in Figure 34. The Nozzle size letter is stamped on the collar of the Fluid Needle and on the outer edge of the Fluid Tip. Sizes

E-FF-FX-F are generally used. Size E is furnished with standard equipment.

#### 1-9-4, OPERATION OF SPRAY EQUIPMENT

##### (A) MASKING

Before starting to spray, all surfaces which are not to be painted shall be masked. Large surfaces may be covered with drop cloths or a combination of heavy kraft paper and masking tape. Do not use newspaper. The lapping of masking tape over onto bulkhead when objects such as switch boxes are sprayed will necessitate touch up by brush. Confine masking to the area to be masked and touching up will be eliminated.

##### (B) SPRAY PAINTING TECHNIQUE

The handling of a spray gun is best learned by practice. However, a few pointers on the subject are pertinent. At the beginning, make sure the spray gun is thoroughly clean. Strain paint through screen wire or cheese cloth as it is poured into the spray container. Air pressure to the gun should be adjusted to approximately 45 or 50 lbs. for lacquer and thin liquids and 60 to 70 lbs. for paint and enamel. Initially, adjust fluid pressure to 10 or 15 lbs. for lacquer and thin liquids and 15 to 20 lbs. for paint and enamel.

Having made the initial adjustments to air and liquid pressures, final adjustments are made by observation of spray patterns. Normal spray patterns will appear as illustrated in Figures 35 and 36.

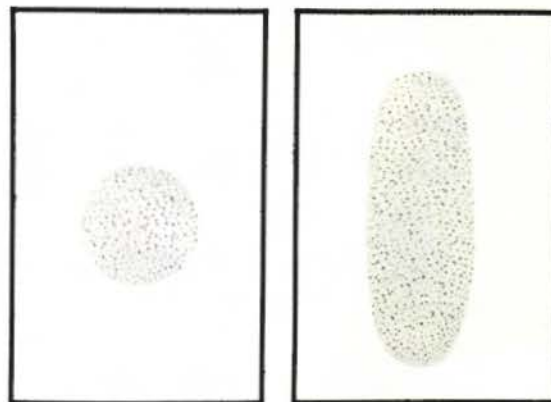

Figs. 35, 36. Normal spray patterns.

Imperfect spray patterns are due to one of two basic troubles, i.e., clogging of passages or improper balancing of air and fluid pressures.

Imperfect patterns due to clogged passages will take the following forms:

1. Heavy Top Pattern (Figure 37). Due to:
  - (a) Horn Holes partially plugged.
  - (b) Obstruction on top of Fluid Tip.
  - (c) Dirt on Air Cap Seat or Fluid Tip Seat.
2. Heavy Bottom Pattern (Figure 38). Due to:
  - (a) Horn Holes partially plugged.
  - (b) Obstruction on bottom side of Fluid Tip.
  - (c) Dirt on Air Cap Seat or Fluid Tip Seat.
3. Heavy Right Side Pattern (Figure 39). Due to:

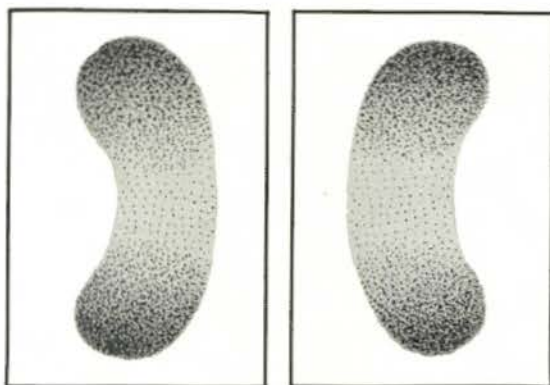

Figs. 39, 40. Imperfect spray patterns.

- (a) Right side of Horn Holes partially plugged.
- (b) Dirt on right side of Fluid Tip.
4. Heavy Left Side Pattern (Figure 40). Due to:
  - (a) Left side of Horn Holes partially plugged.
  - (b) Dirt on left side of Fluid Tip.

It should be remembered that the above troubles could be caused by burrs inside orifices. For this reason, care should be exercised in cleaning so as not to damage or alter the shape of orifices. Always use a piece of wood such as a toothpick for this job. Never use a wire or other hard instrument.

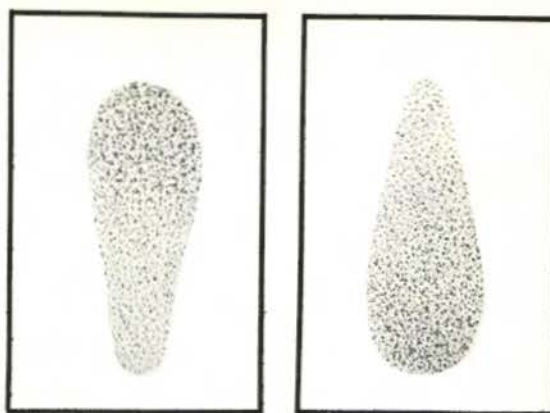

Figs. 37, 38. Imperfect spray patterns.

Imperfect spray patterns due to improper balance of air and fluid pressures will take one of the following forms:

1. Heavy Centered Pattern (Figure 41). Due to:
  - (a) Too low a setting of Spreader Adjustment Valve.
  - (b) Too high fluid pressure.
  - (c) Viscosity of material too great.

It will be noted that adjusting (a) or (b) will accomplish essentially the same thing, i.e., increase the pressure differential between air and fluid pressures. Lowering fluid pressure will decrease the rate of flow of the fluid thereby decreasing the rate of application. Increasing air pressure to the Horn Holes will increase the atomization rate. The choice of which adjustment to make will depend upon the rate of application desired. It is important that the spray gun manufacturer's

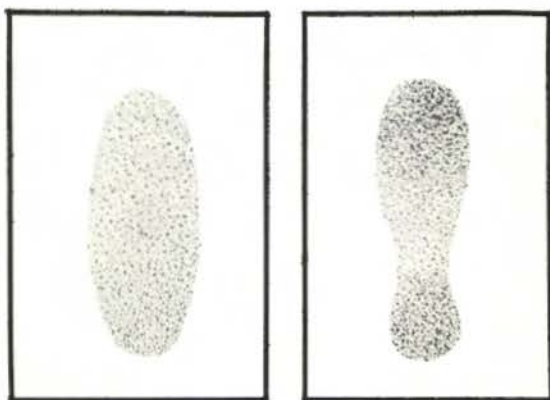

Figs. 41, 42. Imperfect spray patterns.

recommendations be followed both as to type of thinner and its proportion in the spraying material when making adjustment (c). To change a recommended viscosity merely to make it more sprayable is to invite trouble.

2. Split Spray Pattern (Figure 42). Due to:

- (a) Too high setting of the Spreader Adjustment Valve.
- (b) Too low fluid pressure.
- (c) Material too thin.

Here again adjusting (a) or (b) will accomplish the same purpose, i.e., decrease the air and fluid pressure differential. The choice of which adjustment to make again depends upon the application rate desired. Lowering air pressure to Horn Holes by turning the Spreader Adjustment Valve to a lower setting will decrease the atomization rate while increasing fluid pressure will increase the rate of application. Material should never be thinned beyond the manufacturer's recommended proportioning. However, if condition (c) exists, add enough paint as received to the thinned material to restore proper viscosity.

Another common defect in spraying is "Mist" or "Fog," (Figure 43). Due to:

1. Over atomization, caused by:
  - (a) Air Pressure to Gun too high.
  - (b) Fluid Pressure too low.

Again, the air to fluid balance is off. Reducing the differential as for the split spray pattern above will eliminate the mist unless it is caused by:

2. Improper use of the gun.
  - (a) Incorrect stroking.
  - (b) Gun held too far from surface.

Correcting these faults lies with the opera-

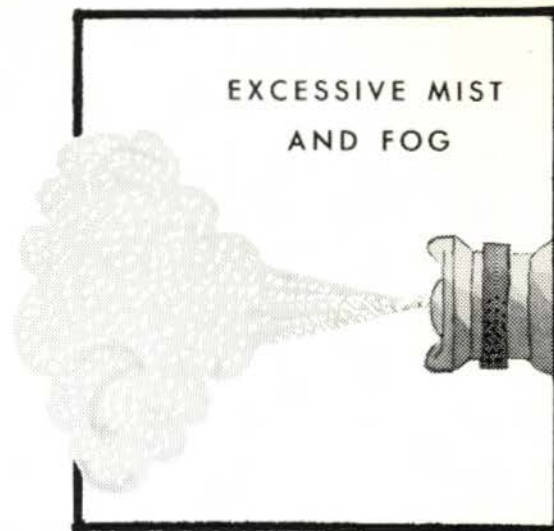

Fig. 43. Improper mist or fog.

tor of the gun. Carefully study Figure 44, which illustrates the correct method of stroking the gun and the correct distance between gun and surface. Improper stroking is shown in Figure 45.

#### (C) PAINT APPLICATION

A good finished paint film depends as much on proper handling of the gun as it does on correct adjustments of the equipment. In general hold the spray gun from 6 to 8 in. away from the surface being painted. This is about the distance of a normal hand spread. Begin the stroke before the Trigger is pulled and release the Trigger before the end of the stroke. This prevents "piling up" paint at the beginning and end of each stroke. Always keep the gun at right angles to the surface —

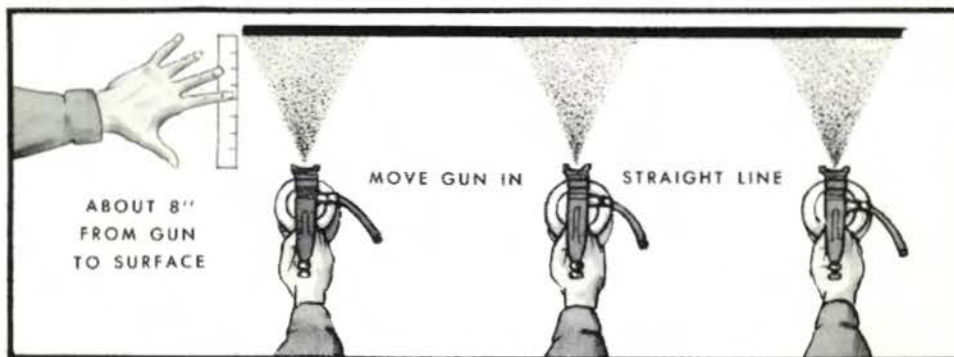

Fig. 44. Proper method of spraying.

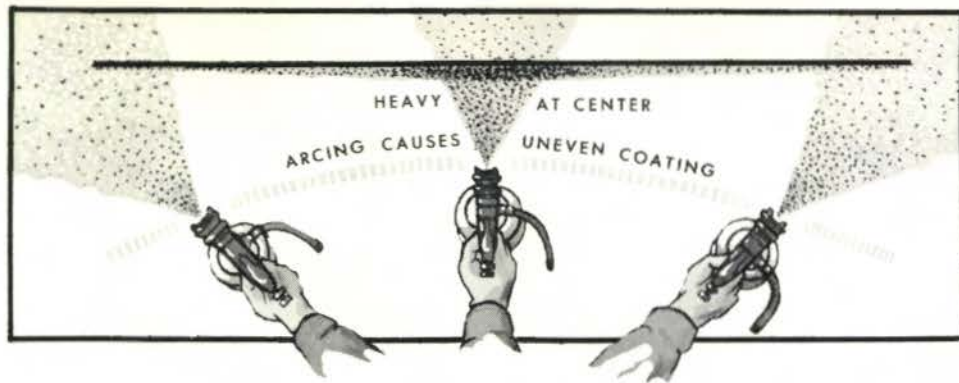

Fig. 45. Improper method of spraying.

never swing the stroke in an arc which would put too much paint in the center of the stroke and too little on the ends. The objective is to obtain adequate coverage with an even application and without runs and sags.

Before applying the overall coat, spray small protruding parts such as hatch casings, door casings, rivet heads and small built-in parts. This will insure adequate coverage and will eliminate bridging and touching up later.

When spraying corners, first spray up to within 1 or 2 in. of the corner; then, turn the gun on its side and hold gun at an angle to corner and, starting at the top, spray downward along the edge so that both sides of the corners are sprayed at once. See Figure 46.

#### (D) SPRAYED FILM DEFECTS

The most common defects in spray paint coatings are: "Orange Peel," Runs and Sags, Pinholes, Blushing, and Peeling. Orange Peel is a general term used to describe a painted surface which has dried with a pebbled texture resembling an orange peel. This may be caused by the use of improper thinners, insufficient atomization, holding the gun too far away from (or too close to) the surface, improper mixture of materials, or low humidity.

Runs usually result from using material which is too thin. Sags result from too much material. They can also be caused by allowing too big a lap in spraying strokes and by poor

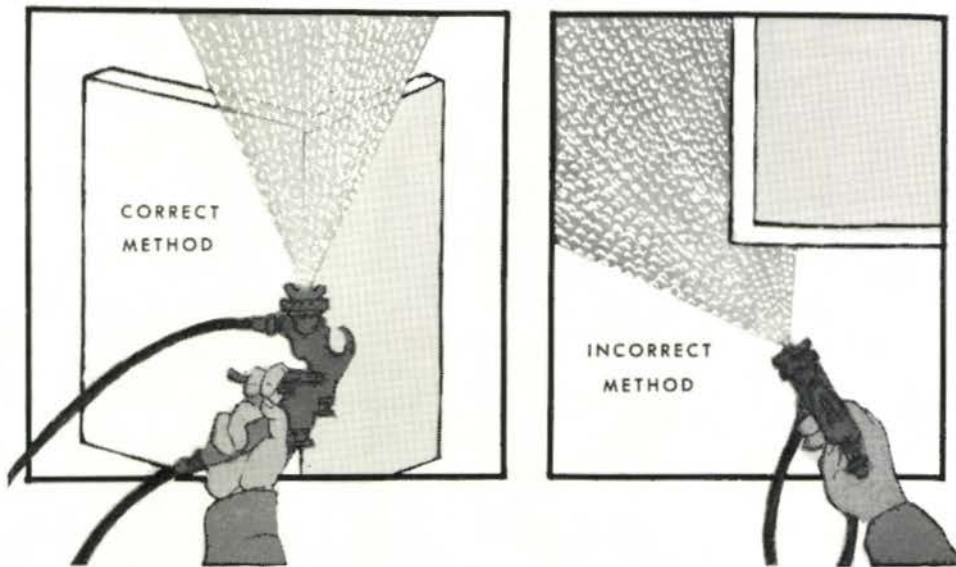

Fig. 46. Right and wrong ways to spray corners.

adjustment of the Spray Gun or Pressure Tank. Dirty or partially clogged passages for air or fluid will also cause uneven distribution.

Pinholes may be caused by the presence of water or excessive thinner in the paint; or by too heavy application of quick-drying paint. In either case, small bubbles form which break in drying, leaving small holes.

Blushing resembles a powdering of the applied coating. The cellulose material in the lacquer separates from its solvent and returns to its original powder form. Water is usually the cause of this — either moisture on the sprayed surface or excessive moisture in the air. When blushing occurs the entire defective area of the coating must be removed because the coating will have poor durability.

Peeling is almost invariably due to careless workmanship in not cleaning the surface properly or incompatibility of paint films. Before any spraying is attempted the surface must be absolutely clean.

#### 1-9-5, CARE OF SPRAY EQUIPMENT AFTER USE

Spray equipment should be cleaned immediately after use. First, back off the Fluid Needle Adjusting Screw and release the fluid pressure from the Pressure Tank by means of the Release Valve. Hold a cloth over the Air Cap and pull the Trigger. This forces the paint back into the Tank. Remove the Fluid Hose from the Gun and run the thinner prescribed for the paint through it. If Air Holes are clogged, use a toothpick to clean



Fig. 47. Steps in cleaning a container type gun.

them out. Put all clean parts back in place, and the Gun is ready for use again.

To clean an Attached-Container Type Gun, first remove the Container. Place the Pick-Up Tube over a waste bucket. Hold a cloth over the Air Cap and pull the Trigger clearing the gun of paint. Empty the Container and spray in the usual way. This process cleans out all passageways. Clean the Air Cap by soaking in a solvent, then replace. Never immerse the entire Spray Gun in thinner or solvent because all lubricating oil and grease will be removed and the Packing will subsequently dry out hard. See Figure 47.

Spray Guns require an occasional lubrication. This is a small job but one that is well worthwhile. The Fluid Needle Packing should be removed and softened with oil. The Fluid Needle should be coated with grease or petroleum. All moving and rubbing parts should get a few drops of light oil. Most Spray Guns are provided with Oil Holes for these parts.

For cleaning or repair, or when changing the color of paint used, the Spray Head may have to be changed. Remove the Gun from the Liquid and Air Hose Lines. Hold the Gun in the left hand, pull the Trigger all the way back and loosen the Locking Bolt with a wrench. Push the Trigger forward as far as possible. Then pull the Spray Head forward. To replace the Spray Head, push the Trigger forward and insert the Spray Head. Then hold the Trigger back and tighten the Locking Bolt. See Figure 48.

#### 1-9-6, SAFETY PRECAUTIONS FOR SPRAY PAINTING — GENERAL

##### (A) FIRE AND EXPLOSION PRECAUTIONS

Most paints, formulated solvents and thinners other than water are volatile and flammable and can create an explosive atmosphere in the work area when sprayed. The possibility of an explosion occurring varies in accordance with the flash point of the material and the ambient temperature of the air in which the spraying is being done. The hazards for outside painting and in semi-enclosed spaces are less severe and are essentially limited to the fire hazard in the immediate vicinity of the



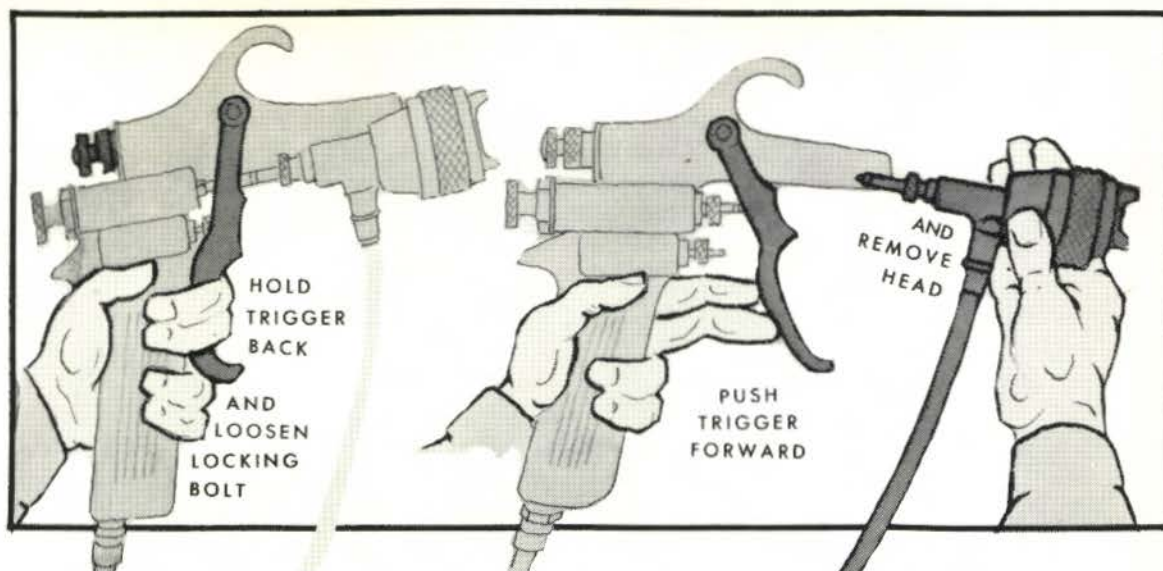

Fig. 48. Removing the spray head.

spraying. No cutting, welding, burning is allowed in the immediate area during painting operations.

In any case where interior spray painting is being done with low flash point materials (flash point below 100° F.), ventilation shall be provided to keep vapor concentrations below the explosive range in all parts of the enclosure. This will require roughly 1500 cu. ft. of fresh air per minute for each spray operator. Blower exhausts and intakes must be sufficiently separated to guard against recirculating fumes. The vapors of most paint solvents and thinners, other than water, are heavier than air and tend to accumulate in the lowest portion of a compartment. Ventilation must reach all parts of the tanks or compartments to avoid such accumulations. Blowers should be located outside the area being sprayed. If they are located within the hazardous area, they must be powered by air or explosion-proof electric motors in safe working condition. Ventilation must continue after spraying is completed until all explosive fumes are purged from the enclosure.

No smoking, welding, burning, or other flame or spark-producing operations such as chipping, grinding, etc., shall be allowed within a work area while spraying is going on or for at least one hour after spraying has ceased.

#### (B) AIRLESS SPRAY EQUIPMENT

Airless Spray equipment will generate exceedingly high air pressures which are quite dangerous. All connections and hoses must be kept tight. The gun may spray at a rate up to 80 ounces per minute through a fine point. Such high pressures will pierce human flesh and tissue if the spray cap on the gun head is held too close to the human body. It is equally dangerous to operate an airless gun when the cap has been removed. This could release a large volume of liquid, and great bodily harm could result. The following precautions should be observed.

1. Check all hose connections and fittings for leaks. Be sure that all parts used are specifically for high pressure use.
2. Keep a constant check on the hose to make sure it is free of worn spots, breaks, cracks, etc. Keep the hose away from moving parts of machinery, sharp edges, chemicals.
3. When holding the airless spray gun keep fingers off the trigger except when gun is in actual use.
4. Never point the gun at anyone — including yourself or any parts of your body.
5. Be sure pump pressure is released before the gun or any parts are disconnected.
6. If materials used are highly flammable, the object or surface being sprayed, as well

as the spray gun, motor and pump should be grounded. This is highly important since the spray gun may accumulate a high voltage electrostatic charge. Watch for all sources of possible ignition.

### (C) HEALTH PRECAUTIONS— RESPIRATORS

Spray painting breaks up the paint into a fine spray in which fumes, pigment and vehicle are released in the air. Breathing these fumes and particles or otherwise absorbing them into the body can cause injury. Always wear a respirator when spraying or when in the vicinity of spray work. The most common types are:

1. The filter respirator, equipped with filter pads, can be used in spraying, grinding, or dust blowing work when dust and fumes are not too severe. See Figure 49.

2. The cartridge respirator, designed for more severe conditions than the filter respirator, is equipped with a large purifying cartridge made of chemically treated charcoal, in addition to a filtering pad. Stock No. G4240-276-8935.

3. The dust respirator contains a replaceable cartridge and is easy to wear due to its light weight. This respirator may be used for surface preparation operations but it is relatively ineffective for paint spraying and shall not be used for this purpose.

4. The air supply respirator provides complete protection when working in holds and tanks. This type is supplied with fresh air by a compressed air line, purified by a charcoal cartridge, and then fed to the breathing compartment of the respirator. Stock No.

G4240-275-3178 (half mask), or G4240-275-3177 (full face piece). See Figure 50.

5. The hood respirator consists of a flame-proof cloth hood, a fiber headgear, a metal eye-piece, an air filter, and an air hose. The neck cloth at the bottom of the hood ties snugly around the neck. The opening in front of the hood is the only outlet for a constant flow of air entering through a hose at back of the hood. Foul air cannot enter because pressure inside the hood is slightly greater than pressure outside.

If air for supplied-air masks or hoods is taken from a central source, its purity must be safeguarded by a carbon monoxide alarm on each compressor and no anti-freeze shall be used in the lines.

### (D) SKIN AND EYE CARE

To reduce the danger of absorbing chemicals through the skin when spray painting, keep well covered. Apply a light coating of protective cream on exposed areas of skin, such as the hands, and wear gloves. This will provide protection and will aid in cleaning up afterwards. Wear goggles when spray painting. Getting paint in the eyes can cause a great deal of suffering and may permanently impair eyesight. See Figure 51 for typical clothing and protective devices used in spray painting.

## 1-9-7, SPECIAL PRECAUTIONS FOR INTERIOR SPRAY PAINTING

### (A) INTRODUCTION

The following safety practices should be followed explicitly.

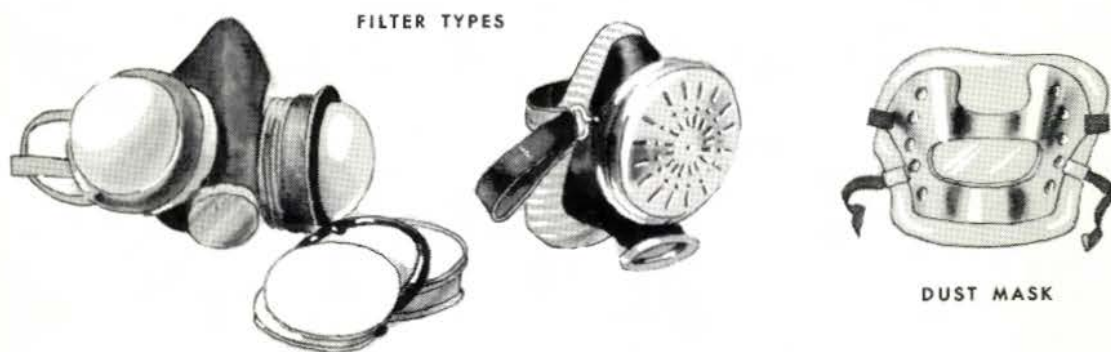

Fig. 49. Typical filter respirators.

LOWER EXPLOSIVE LIMITS OF SOME  
SOLVENTS AND DILUENTS



Fig. 50. Air supply or air fed respirator.

Because of the accumulation of combustible gases in interior painting, a great deal of care must be taken to avoid explosions. Thus the points of this article must be read with care. The safety practices given are mandatory and must be followed as set forth.

An explosion is a rapid combustion of gas

FLASH POINTS \* OF VARIOUS  
SOLVENTS AND DILUENTS

Ethyl Alcohol	68
Acetone	16
MEK (methyl ethyl Ketone)	30
Toluene	56
MIBK	81
n-Butyl Acetate	92
Cellosolve	126
Isophorone	202
Mineral Spirits	100†
Xylene	80†
Iso propyl Alcohol	70
Naphtha, Coal Tar	100 to 110†

\* °F Tag Open Cup

† Tag Closed Cup

(% by Volume  
in Air)

MIBK	0.9
Xylene	1.0
Toluene	1.27
n-Butyl Acetate	1.7
MEK (Methyl ethyl Ketone)	1.8
Acetone	2.55
2-Nitropropane	2.6
Cellosolve	2.6
Methyl Alcohol	6.7
Ethyl Alcohol	3.3
Propyl Alcohol	2.5
Iso propyl Alcohol	2.5

The values listed above may vary slightly depending upon purity of sample. Also the closed cup yields a lower value than the open cup method.

(vapor), usually in an enclosure. For an explosion to take place, there must be a certain vapor/air ratio present. The higher the ambient temperature, the more rapid is the generation of vapor from the solvent.

The principal measure of the explosive hazard for interior application is the flash point temperature of the paint solvents. At temperatures above the flash point, a fire or explosion may occur if an open flame or spark is present. The flash points of typical solvents used in coatings are given in an accompanying Table.

A notice of precaution and directions for safe application is marked on most containers of paints possessing low flash points when procured under Coast Guard specifications.

Explosions occur principally for the following reason: solvent vapor concentration is higher than allowable. If the vapor concentration is kept below the lower explosive limit and is actually determined to be so by *careful* and *consistent* explosimeter readings, no explosion will occur during painting with even the most volatile solvents irrespective of sparks or flames which may be present.

*Maintenance of an explosive free atmosphere is more important in the prevention*

*of explosions than all other safety precautions combined.*

Many of the safety instructions appear to be established to prevent a fire or explosion from occurring by reason of vapor-laden air being discharged into the area around the work. By providing proper ventilation and measuring explosive concentrations, many safety precautions now regarded as essential become less critical.

#### (B) TO PREVENT EXPLOSIONS

The safety instructions herein are based not only on a recognition of the explosive hazard of paint solvents but the need to carry out painting by both experienced painters with all necessary safety equipment and inexperienced personnel who are assigned to painting with limited equipment.

These instructions will give some understanding of the kinds of safety precautions needed and the reasoning behind them. As already explained, ample ventilation is the most important safety precaution. The figure established herein (no more than one gallon of paint applied per hour for every 500 cubic feet of fresh air per minute supplied to the compartment) provides a safe concentration of solvents in most of the Coast Guard paints. This is a safety factor of approximately 20 to take care of unequal air distribution. If this figure is uniformly maintained all other safety precautions may be regarded as truly secondary in contributing to the prevention of an explosion. If it is not maintained and air concentrations are not measured in the manner to be specified, all other precautions however elaborate may not prevent explosions.

#### (C) MANDATORY REQUIREMENTS FOR SAFETY

The following precautions concerning ventilation, gas-free testing, and ignition are **MANDATORY** when painting at working temperatures at or above the flash point temperature of the paint.

1. Ventilation. No more than one gallon of paint shall be applied per hour for every 500 cubic feet of fresh air supplied per minute.

Portable type ventilator. Use weather air-exhaust or supply.

When there are openings in the top and

bottom of a compartment, draw air in through the bottom and exhaust through the top.

When there are openings in the top only, extend work duct to a point near the bottom of the tank and exhaust from this area.

When there are openings in the bottom only, extend work duct to a point midway between the top of the tank and the center of the tank in a vertical plane and at about the center of the tank in the horizontal plane, and exhaust from this area. In areas where pocket vapors are not moved by regular ventilation, add small blowers to agitate air.

2. Ignition. Portable lights shall be explosion proof and adequately secured.

All portable blowers shall be equipped with explosion proof motors.

No changing bulbs or repairing any lights within the painting area shall be carried out during painting operations.

All lights and cords shall be completely and properly assembled and in good condition. Acceptable standards are contained in Article 500 and 501, National Electrical Code — MFC #70.

No smoking, welding, cutting, or open flames shall be permitted in the space in which painting is being done. Personnel engaged in painting operations shall not carry matches or cigarette lighters.

Welding or burning in the immediately adjacent compartments or within 50 feet of out-of-door places where coatings are being applied is not allowed.

Painting operations shall be suspended during electrical storms.

#### 1-9-8, FIRE AND EXPLOSION DATA ORGANIC SOLVENTS AND DILUENTS PERTAINING TO ORGANIC COATINGS

The tables on flash point and explosive limits should be consulted for essential information on explosion hazards due to the concentration of organic vapors in the area.

For additional information consult the following: CG-388; NAVEXOS P-422 dated 1954; and National Fire Protection Association Handbook, 12th Edition.

Definitions. Flash point is the temperature to which a liquid must be heated before its vapors will "flash" or burn momentarily when a small flame is applied.

The minimum concentration of a vapor which, if ignited in air propagates flame independently of an external source of heat, is known as the lower explosive limit.

Threshold limit refers to the maximum allowable concentrations of toxic contaminants to which personnel may be exposed during an 8-hour work day over a prolonged period without adverse effects.



Fig. 51. Protective clothing for spray painting.

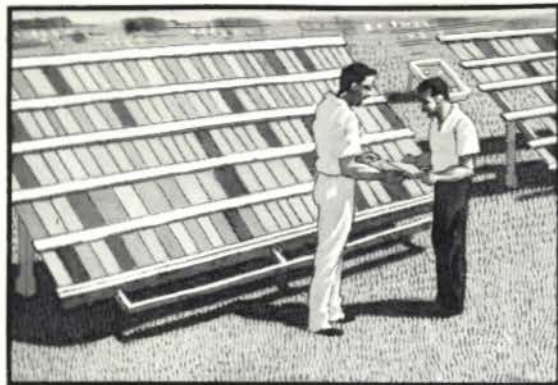

## SECTION 1-10

### PAINT FAILURES

All paints can fail, sometimes badly, due chiefly to four reasons: improper preparation of the surface prior to painting; improper application of the material — which includes selection of the wrong type of coating for a given surface; use of poor quality paint — not a problem if standard Coast Guard or Navy paints are used; and neglecting to determine if a surface is suitable for the application of paint — for example, the moisture content of wood may be too high. The following is a list of the more common paint film defects and failures with notes on how to avoid or remedy the condition.

#### 1-10-1, CHALKING

Chalking is caused primarily by the action of sunlight on a paint film. The non-volatile vehicle (binder) at the surface of a paint film is degraded by the ultraviolet rays in sunlight. This leaves loosely bound particles of paint on the surface which wash off during rain. Slight chalking is desirable because it makes the surface self cleaning. Heavy chalking is highly undesirable as it washes away rapidly, leaving the surface unprotected. Heavy chalking on wood usually occurs on wood surfaces which were not properly primed and did not receive an adequate number of finish coats. The porous wood sucks the oil out of the paint thus promoting early, heavy chalking. This condition can be avoided by properly applying a primer-sealer followed by a sufficient number of finish coats (usually 2). To remedy the condition, remove the heavy chalk by scrubbing or wirebrushing, then repaint.

Chalking which occurs on metal surfaces is generally due to excessive pigment to vehicle ratio or an inferior type vehicle (binder). Scrub the surface until free of chalk, and recoat.

#### 1-10-2, ALLIGATORING

Alligatoring and checking of a paint film exists when the outer layer of paint cracks and presents a pattern similar to alligator leather. The condition occurs when relatively hard finishing coats are applied over relatively soft priming or underlying coats. Undercoats which are too rich in oil, or which have been allowed insufficient drying time, cause this softness. Expansion and contraction of the painted surface where paint coats have unequal flexibility due to soft undercoats and hard outer coats causes alligatoring and checking. To avoid this failure, allow undercoats to dry sufficiently hard before applying the next coat. Undercoat materials should dry harder than top coat materials. Do not add too much oil to priming materials. To remedy this condition, scrape and wirebrush to remove loose scale, sand to smoothness and repaint.

#### 1-10-3, FLAKING, CRACKING AND SCALING

Flaking, cracking and scaling are conditions caused by either painting over wood which is saturated with water (over 25% moisture) or by painting over resin pockets and knots in pine wood. In the former case, adhesion is poor and shrinkage of the wood, upon drying out, causes the paint film to crack and flake off. Wait until the weather is dry

— at least a week after a rainy period — before attempting to paint exterior wood. In the latter case, resin in the wood bleeds into the paint, making the film too hard and brittle. When this occurs, the paint film lacks the flexibility necessary to withstand expansion and contraction of the wood due to temperature changes. To prevent this condition, seal resin pockets with Ready-Mixed Aluminum Paint and prime bare wood surfaces with Exterior Wood White Primer.

#### 1-10-4, BLISTERING

Blistering is a term applied to a paint failure where large blisters appear in the paint film — usually the top coats lift, leaving the prime coat intact. This condition is the result of moisture being absorbed by the wood. Moisture may come from steamy kitchens or bathrooms, leaks in roofing or plumbing, or leaks around window and door casings. Exposure to heat from the sun causes this moisture to migrate to the surface of the wood and collect under the paint film to form blisters. This condition can be alleviated by either reducing humidity inside the building to safe limits or preventing the moisture from reaching the siding. Humidity inside the building can best be controlled by proper ventilation, repairing leaks in walls, roofs and plumbing, and by operating humidifiers at lower settings. Moisture can be prevented from reaching siding by installing vapor barriers between plaster and insulation in new construction or by the application of moisture-resistant paint to interior sides of exterior walls and ceilings of existing buildings. After the cause has been rectified, scrape and sandpaper blistered areas, then repaint.

#### 1-10-5, GAS DISCOLORATION

Gas discoloration sometimes occurs in white or light-tinted paint films in areas where industrial fumes or sewer gases are prevalent. Hydrogen sulfide reacts with lead compounds in the paint to form gray or black lead sulfide which resembles graphite. This condition is usually found on newly applied soft paint films (3 to 6 months old) which are permeable to the hydrogen sulfide gas. Affected paint films may lighten up during periods of gas-free air. If it is necessary to remove

the deposits of lead sulfide immediately, sponge with hydrogen peroxide or a weak solution of acetic acid or muriatic acid, avoiding contact of acid solutions with the skin. Flush the area with fresh water to remove chemicals. Where gas discoloration persists, wash the surface and repaint, using a fume-resistant paint. (Federal Specification TT-P-103.)

#### 1-10-6, MILDEW

Mildew affects paint films oftenest in southern localities where humidity and warm temperatures are suitable for its growth. Mildew grows to produce a black (*aspergillus niger*) or green (*penicillium glaucum*) discoloration. Mildew spores in the air stick to tacky paint films and grow in colonies. Mildew does not grow any better on painted surfaces than on many other surfaces. Use a powerful magnifying glass to determine if mildew is actually present. The soiled appearance may be dirt rather than mildew. A simple test for mildew would be to apply a dilute bleach solution to the affected area, such as Clorox in water. Loss of color on the surface would indicate the presence of mildew. Dirt would not be affected. Dirt washes off much easier than mildew. Badly mildewed surfaces must be thoroughly scrubbed with soap and water before repainting. Rinse with fresh water and allow a day or two for drying. Add a prepared mildewcide to new paint and mix thoroughly. These compounds may be purchased at paint stores and very small amounts of the order of  $\frac{1}{2}$  oz. to 1 gal. of paint are needed. The use of mercury compounds is prohibited, due to their toxicity.

#### 1-10-7, SUCTION SPOTTING

Suction spotting is a curious light spotting which occurs usually within 3 to 6 months of application, on light gray and other light tints. This condition is caused by porous areas in the surface of wood which absorb oil from paint, leaving insufficient binder in the paint film to resist weathering. This condition is generally observed in 2 coat systems on wood. Properly applied primer-sealer with a sufficient number of finish coats (usually 2) will prevent such spotting.

1-10-9

### 1-10-8, DIRT COLLECTION

Dirt collection on a painted surface indicates that either there is excessive dirt in the atmosphere or that the paint film is not chalking properly, or both. In industrial areas where dirt content of air is high, delay new painting until time when minimum winds prevail. Addition of oil to paint cuts down the ratio of pigment to vehicle and aggravates the condition. To alleviate the condition, scrub with soap and water. Rinse with fresh water. Any new painting should be done with a chalking paint. Thin with paint thinner, if necessary, but do not add oil which inhibits chalking.

### 1-10-9, PEELING

Peeling is a condition in which a loose edge of coating, perhaps where a blister has been broken, can be grasped and pulled loose progressively beyond the margin of the blister. Sometimes long strips of paint coating can thus be peeled off. As a rule, the condition lasts only as long as wood and coating remain wet. When dry, the coating becomes too brittle to be peeled off, but on weathering the coating comes loose and curls progressively in what is more properly called scaling. Peeling and flaking on metal surfaces results, in many instances, from loss of adhesion due to poor surface preparation.



Failure of high quality coating due to application over dirt contaminated surface. Official Coast Guard photograph.



## SECTION 1-11

### SUPERVISION OF PAINTING



#### 1-11-1, FREQUENCY OF PAINTING

It is of paramount importance to bear in mind that the cost of painting is relatively high. For example, during the calendar year, the value of paint materials used in the Coast Guard approximated \$1,000,000. The cost of application is approximately five times the cost of paint materials. When the labor is taken into account, the painting costs to the Coast Guard are in excess of \$6,000,000.

##### (A) INTERIOR SURFACES

Interior surfaces, other than those exposed to sweating, are generally painted more frequently than necessary, the painting being more often done for appearance than for protection. It must be borne in mind that too frequent repainting results in paint film failure due to films which are too thick or to films which are incompatible.

Since interior paint films are generally renewed due to yellowing or staining rather than mechanical film failure, the interior paints which have been selected for Coast Guard use are designed to have good scrubability to permit repeated washing. Scrubbing the surface with Paint Cleaner and water will usually result in a reasonably clean, fresh appearance.

Don't waste paint materials on interior surfaces where the paint film is intact and can be cleaned. Eventually, of course, dirt and grease stains will work their way into paint films too deep for removal. When the surface becomes unsightly by reason of these stains, it must be repainted. As a check against too frequent repainting, adequate

painting records should be kept and the date of painting stencilled on the surface as described in Article 1-11-7. Interior painting should normally not be done oftener than every three years.

##### (B) EXTERIOR SURFACES

In exterior painting the most economical practice is to establish a painting schedule. The frequency of painting should be such as to repaint prior to failure of the paint film. Exterior wood surfaces ashore normally will not need painting oftener than every three years. Exterior steel surfaces ashore and those on vessels above the main deck should not normally be painted oftener than every two years. Exteriors of hulls except boot-topping should not be painted more frequently than every year. With these generalizations in mind and taking into account previous practice at individual units, each unit should establish and adhere to a painting schedule. Touch-up painting between the scheduled periods will be all that is necessary to protect the surface and impart a satisfactory appearance.

#### 1-11-2, WEATHER CONDITIONS FOR PAINTING

Painting shall only be done under such weather conditions as will insure a dry surface and no precipitation.

In order to insure a dry surface the temperature of the surface must be above the temperature of the dew point. If the temperature of the surface to be painted is at or below the dew point temperature, conden-

sation will occur on the surface. Visual examination of the surface for condensation cannot be relied upon since condensation, although it exists, cannot be detected until it is in an advanced stage. The dew point, of course, depends upon the relative humidity and the air temperature. Below is a table showing the temperature of the dew point corresponding to any given wet and dry-bulb temperature.

After selecting the dew point from the table compare it with the temperature of the surface obtained by taping a thermometer to the surface (in a location where it will not be damaged) for a period of five minutes. *If the temperature is at or below the dew point do not paint.* It is best to paint only when the temperature of the surface is several degrees above the dew point.

In general, do not paint when either the temperature of the surface or the air temperature falls to 50° F. or below. Paints dry by the combination of three totally different reactions, i.e., evaporation, oxidation, and polymerization. These reactions must proceed at a given rate with respect to one another in order to obtain a dry film with

#### TEMPERATURE OF THE DEW-POINT

*Temperature Difference  
(Dry Bulb—Wet Bulb)*

<i>Dry Bulb Temp.</i>	1	2	3	4	5	6	7	8	10	12	14
90	89	87	86	85	83	82	81	79	76	73	70
85	84	82	81	80	78	77	75	74	71	68	64
80	79	77	76	74	73	72	70	68	65	62	58
75	74	72	71	69	68	66	64	63	59	55	51
70	69	67	65	64	62	61	59	57	53	49	44
65	63	62	60	59	57	55	53	51	47	42	37
60	58	57	55	53	51	49	47	45	40	35	
55	53	51	50	49	47	44	42	40	33		
50	48	46	44	42	40	37	34	32			
45	43	41	38	36	34	31					

To use the table enter the row corresponding to the Dry-bulb thermometer temperature and locate the Dew Point temperature under the column heading which is equal to the difference between Dry and Wet-Bulb temperatures.

optimum characteristics. Paints are so formulated that at approximately 70° F. these three drying actions are in balance with one another. The greater the temperature difference between 70° F. and the temperature at which the paint is applied, the poorer performance the paint will give. While no definite demarcation exists between a temperature at which painting can be satisfactorily applied and a temperature at which it cannot be applied, 50° F. is generally accepted by painting authorities as the lower limit at which paint should be applied. Vinyl paints are an exception and since they dry by solvent evaporation only, they may be successfully applied by spray in temperatures as low as 5° F. Epoxy Coatings are also an exception since they are of the chemical conversion type. They may be applied at 45° F. and in some cases (see instructions for the specific coating) at 32° F.

During winter, spring and fall the days are short. This delays the start of the painting day until dew and frost have disappeared and the temperature of the surface is above the dew point. The painting day is further shortened by having to stop the work at least two hours before the temperature of the surface is expected to drop below the dew point to allow the paint time to set before being exposed to moisture.

Regardless of the season or temperature, painting should not be done when fog, mist, drizzle, or rain is expected or occurring.

#### 1-11-3, ORDERING PAINTS

Most vessels and shore establishments maintain paint lockers and keep an allowance of paint on hand. These allowances are necessarily low due to the fact that paint deteriorates in the container. Therefore, only enough paint for routine maintenance should normally be kept in the paint locker. Prior to the painting season, larger stocks should be obtained.

In order to prevent overage paints, always use the oldest paints first when undertaking a paint job.

When ordering paint, first check Chapter 4 of this Manual to determine what paint is authorized for the intended purpose. State correct name, stock number and amount of

the material on requisition and submit to your supply support activity. For large jobs such as the exterior of buildings or ships, requisitions should be made well in advance of the contemplated accomplishment date. At least 30 days should be allowed to insure receipt of the material in time for the job. It should be pointed out that lack of foresight in procurement of paint materials, resulting in so-called "emergency" open market procurement, increases material costs by as much as 300% and usually results in the application of inferior materials. The best guide for determining the amount of paint to order is previous experience. If paint records are properly maintained in accordance with Article 1-11-7, information will be readily available to permit accurate estimation of paint quantities needed for a particular job. Where information is not available, paint quantity needed must be estimated.

Estimating the proper amount of paint for a particular job takes a great deal of experience. The coverage of a paint for a particular job depends upon (a) the type of paint—some paints are absorbed more easily than others and some paints are more viscous than others leaving a thicker surfacing film; (b) the material to which it is applied—there is a wide variation in the degree of absorption by different materials; and (c) the degree of surface irregularity.

In order to take the above three factors into consideration, it is necessary first to estimate the coverage of a flat surface in terms of sq. ft. per gal. These data appear in an accompanying table.

Having obtained the coverage on a flat surface from the table, multiply the flat surface coverage by an arbitrary factor to account for surface irregularity. The result-

#### COVERAGE IN SQ. FT. PER GALLON ON A FLAT SURFACE

<i>Surface and Material</i>	<i>1st or Primer Coat</i>	<i>2nd Coat</i>	<i>3rd Coat</i>
Siding and Trim Exterior Oil Paint	350	400	450
Porch Floors and Steps Deck Paint	300	400	450
Asbestos Wall Shingles Exterior Paint	150	300	
Shingle Siding Exterior Oil Paint	250	300	
Shingle Roofs Roof Paint	100	200	
Brick Exterior Exterior Oil Paint	150	300	
Interior Doors and Windows Interior Gloss Enamel	350	400	450
Walls, Smooth Finish, Plaster Interior Gloss or Semi-Gloss Oil Paint	350	400	450
Interior Latex Emulsion Paint	450	500	
Plasterboard (Sheetrock) Interior Gloss or Semi-Gloss Oil Paint		400	450
Interior Latex Emulsion Paint		450	500
Metal Pretreatment-Wash Primer	300		
Quick Drying Red Lead Primer		300	
Exterior Enamel			350

## 1-11-4

ing coverage figure should be a reasonably accurate estimate of the amount of projected surface area that a gallon of paint will cover. Sample irregularity factors are given herewith.

<i>Surface</i>	<i>Irregularity Factor</i>
Vessel, Overheads	.50
Bulkheads	.70
Building, Ceilings	.90
Walls	.80

### 1-11-4, ORGANIZING FOR THE JOB

Organization is absolutely necessary. It helps save time and material. It has a good effect on the men because they know what is expected of them. Whatever system is used, it should be carefully planned. No system will work equally well throughout the service. The best system for a particular unit can only be determined by experience. However, the following points will apply universally:

1. Insist on a clean, well conducted paint mixing room and paint locker.

2. Develop a full knowledge of various surfaces and how to prepare them for painting.

3. Gain an understanding of weather conditions and how to avoid dangers of painting when conditions are unfavorable.

4. Learn to gauge the number of man-hours a job will take.

5. Let the men know that you have a personal interest in the job by keeping a close check on them and their work. Insofar as practicable inspect each phase of the work as it is completed, i.e., surface preparation, priming and finish coat.

6. Instill in the men a sense of personal responsibility in doing the job well.

7. Know the capabilities of your men. Put the right man in the right place.

8. Promote a spirit of carefulness. Impress upon them the importance of keeping their equipment clean and stress the dangers of smoking on the job or storing oily rags or cloths where spontaneous combustion can occur.

9. See that the best painters do not have to waste time delivering paint, preparing materials, or moving equipment. Let someone else do these tasks.

10. Arrange for paint locker personnel to have an early breakfast and to "turn to"  $\frac{1}{2}$  hour before the painting crew in order to have all paints mixed, brushes prepared, etc. They should also remain on the job after the paint crew has finished its work in order to clean brushes and leave the paint locker properly secured. Compensatory time off may be allowed paint locker personnel during the day when the workload in the paint locker is light and on rainy days.

11. Arrange for petty officers and leading seamen to also "turn to" prior to scheduled working hours when staging or scaffolding is to be rigged. Paints, paint brushes, spray guns, mechanical and hand cleaning tools, staging and scaffolding should be ready and waiting by scheduled "turn to" time. Painting should not be secured more than 10 minutes prior to the close of scheduled working hours. This will be adequate time for returning materials to the paint mixing room. Generally speaking, too much time is lost in "standing by to stand by."

By applying these principles in conjunction with practicing painting economy, a supervisor can earn his pay many times over.

### 1-11-5, SCAFFOLDING

In order to paint high and low places which are normally out of reach, various types of ladders, scaffolds, and staging are used. The boatswain's chair is frequently used and is essentially a one-man stage. The swinging stage is used when two or more men are working. It is suspended by block and tackle and can be raised or lowered as required. Where staging or boatswain's chairs cannot be suspended from above, ladders and scaffolding are employed. Ladders are used at shore establishments where only one workman is required and where the height is relatively low (20 ft.). Where more than one workman is required, scaffolds are constructed of sound structural timbers, well shored, with wide horizontal boards having a minimum width of 20 in., supported at intervals not exceeding 8 ft. from which to work. The working platform shall be secured to the bearers. Top and center guard rails will be provided on staging 8 ft. or more in height.

Workmen on any type of scaffold or stage should be constantly tended by someone on deck. Each man over the side of a vessel shall wear a lifejacket and shall have a life-line looped around his chest under his arms and secured on deck. These lines will require tending whenever the stage is raised or lowered; also the men will need paint materials at intervals. Scaffolds should be kept clean of loose materials such as tools, scraps of material, and other stumbling hazards. Portable electric wire and lines which may trip or throw a man are also dangerous. Loose clothing such as long sleeves and trousers which are too long or which have loose cuffs are extremely dangerous to wear on staging. Other hazards are improper rigging, falling objects, taking unnecessary risks, and daydreaming.

When working aloft or over the side, all tools shall be secured by a lanyard to either a substantial part of the ship or to the worker, depending on the size and weight of the tool. There is no excuse for dropping tools on people below or for dropping tools over the side. Portable electric tools used for preparing surfaces to be painted shall be checked for grounds at least once each week and shall be grounded while in use.

Ladders, boatswain's chairs, stages and scaffolding materials shall never be painted. Painting such equipment covers any existing defects such as cracks, breaks, and dry rot. Paint drippings should be cleaned up while still wet and shall not be allowed to accumulate. Ladders, boatswain's chairs and stages shall be cleaned to bare wood and coated with boiled linseed oil for protection. Careful inspection of all such equipment before use is mandatory.

Where metal ladders are used they shall be considered the same as any other metal tool and precautions established accordingly. All ladder side rails and other supporting legs shall be equipped with safety feet of a non-conductive material fastened so that no metal is exposed on the bottom.

#### 1-11-6, CONTROL OF FILM THICKNESS

The protection afforded by a paint film is, within certain limits, directly proportional to the thickness of the film. It is believed that

the dry paint film thickness is more important than the number of coats, since after the paint has dried only the dry film remains to protect the surface. The number of coats is of concern only in minimizing the possibility of holidays. It is difficult to estimate just how thick the paint film on a particular surface should be without being cognizant of prevailing conditions. However, with the view in mind that the most economical thickness which will afford the desired protection is the one to use, it has been determined that dry paint films on exterior steel such as ships' hulls and superstructure should be at least 8 mils thick and for interior steel on ships 5 mils. Proper application of the painting system specified in Chapter 2 for these surfaces will yield paint films having these minimum thicknesses.

Film thicknesses are criteria for service life of coatings only when the film thickness is built up from the bare surface as a system. Theoretically, once a surface is properly prepared and adequate film thickness is built up as a system, this expensive operation need not be repeated provided a definite inspection and touch-up system is established and that local wirebrushing, spot priming and cover coating is done as soon as inspection shows the slightest indication of localized failures. While this theory may not be one hundred per cent true, it is a fact that the frequency of surface preparation and complete repainting can in most cases be greatly reduced by application of the above principles.

The importance of applying the entire prescribed coating system at one time rather than applying only part of the system, such as applying only one finish coat where two are prescribed, cannot be too strongly emphasized. Applying less than the minimum film thickness at one time and then applying subsequent coats at a later date is an uneconomical practice. Films thinner than the minimum film thickness are too permeable to moisture for the conditions to which they are exposed. The sub-surface will be attacked and breakdown of the paint film will have commenced, even though it appears to be in good condition, before the application of additional coats of paint increases the film thickness to the prescribed minimum for

adequate protection. Frequent repainting indicates previous films were too thin for adequate protection and covering failure spots with another thin film is not the answer to the problem. Frequent repainting is also expensive due to the fact that the surface must be prepared to receive the paint prior to each coat. It is estimated that surface preparation constitutes approximately half the cost of a paint job. Therefore, it is of the utmost importance that the job be done properly in the beginning. Prepare the surface properly; build up the minimum film thickness as a system by applying the prescribed number of coats of the specified material; establish a definite inspection system; wirebrush, spot prime and build up film thickness on localized failure spots as soon as the slightest failure is evidenced.

Generally, the first indication of paint film failure will be found over edges, welds and projections. To insure adequate coverage when applying the paint by brush, first coat all edges and sharp corners as a preliminary to applying the overall coat. Apply the overall coat without waiting for the preliminary coat to dry. Follow the system of "laying on" and "laying off" as described in Article 1-7-4, Brushing Technique. The preliminary coating of edges and corners is not counted as a paint coat, but is considered a part of each regular coat. On spray painting the same preliminary treatment of coating edges and corners should be applied. It will be found that a double pass spray coat is about the equivalent of one brush coat. In some cases coverage can be insured by using alternate color coats of the same material, for example, anticorrosive bottom paints which are available in red and brown, to eliminate holidays.

Film thickness on steel can be checked with film thickness gauges after the film has dried. Film thickness gauges are relatively simple devices which measure the strength of a magnetic field which passes from one pole of a permanent magnet through the paint film, across the painted steel surface and back through the paint film to the other pole of the magnet. The strength of this magnetic field which is proportional to the thickness of the paint film, is measured by a meter calibrated in mils of paint film thickness.

While these devices act on a very simple principle, they are delicate precision instruments and must be handled with care. These instruments are not available to the field in general but are available to buoy depots, district offices and inspectors.

The "Elcometer" and "Mikrotest" are two examples of such instruments in wide usage.

### 1-11-7, PAINT RECORDS

In order to eliminate substandard materials, records must be kept which will identify the particular paints that were applied to a surface where early paint failure was experienced. Therefore, records shall be kept on each paint job other than minor touch-up work. Aboard ship this information shall be entered in the Hull History. At shore establishments, a Painting Log shall be kept. These records shall have separate pages for each compartment or room and for the exterior of superstructures or buildings. The following information is to be recorded whenever complete repainting is done.

1. Date of application.

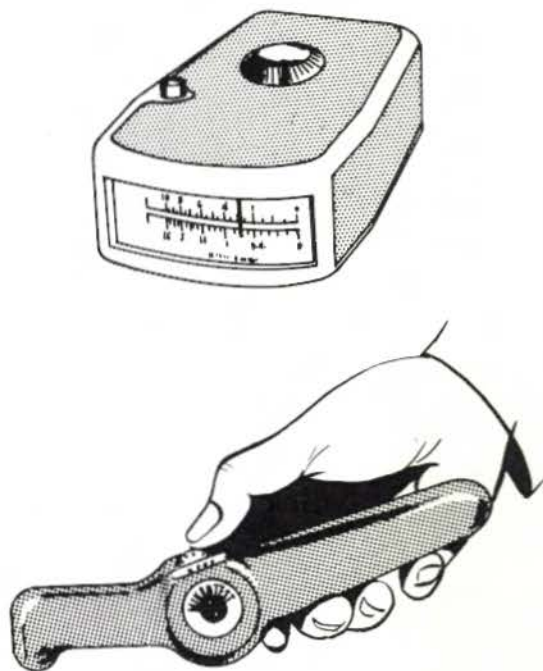

Film thickness gauges, Elcometer (above) and Mikrotest.

2. Area painted.

3. Name of each finish material used, number of coats. Specification number, name of manufacturer, date of manufacture and manufacturer's lot number.

4. Number of gals. of each type paint used.

5. Temperature ° F.

In addition to recording the above information, the date of application shall be stencilled on the painted area in an inconspicuous location. This practice will aid in planning future workloads and future material needs by giving visual evidence of how a paint film is holding up. It should also prevent the waste of materials through unnecessary and frequent repainting, since it is a constant reminder of the time interval since the last painting. The stencil will also give a cross-check on the Hull History or Painting Log.

"Defective paints should be reported as instructed in 1-3-15

### 1-11-8, CONTRACT PAINTING

In any case where contract painting is done, specifications shall be written to guard against inferior workmanship, materials and other detrimental factors which would shorten the service life of the paint film.

Painting specifications shall be based upon instructions promulgated in the Coast Guard Paint and Color Manual and shall contain all pertinent instructions applicable to the job including weather conditions suitable for painting, surface preparation, the painting systems to be used, paint materials to be used, methods of application, quality of the finished job and the general condition of the premises upon completion.

Repair and construction contracts may specify contractor furnished paint when the agreement specifies painting by the contractor and contains the paint specifications and requirements for surface preparation and coating applications required by the Paint and Color Manual.





# CHAPTER 2, COATING SYSTEMS

## TABLE OF CONTENTS

Section	Title
2-1,	INTRODUCTION: COATING SYSTEMS
2-2,	COATING SYSTEMS FOR SHORE ESTABLISHMENTS
2-2-1,	WOOD SURFACES
2-2-2,	METAL SURFACES
2-2-3,	MASONRY SURFACES
2-2-4,	COATING SYSTEM FOR DRY WALL CONSTRUCTION
2-2-5,	COATING SYSTEMS FOR ROOFS
2-2-6,	WOOD WATER TANKS
2-2-7,	WINDOW AND DOOR SCREEN FRAMES
2-2-8,	INTERIOR OF REFRIGERATION BOXES
2-2-9,	ROAD AND RUNWAY MARKINGS
2-2-10,	BRIGHTWORK
2-2-11,	SURFACES REQUIRING ACID RESISTANCE
2-2-12,	SURFACES NOT TO BE PAINTED
2-3,	COATING SYSTEMS FOR VESSELS
2-3-1,	PROTECTIVE COATINGS FOR CONSTRUCTION AND MAINTENANCE
2-3-2,	BOTTOM PAINTING
2-3-3,	BOOT-TOP PAINTING
2-3-4,	EXTERIOR OF VESSELS ABOVE THE BOOT-TOP
2-3-5,	INTERIOR OF VESSELS - GENERAL
2-3-6,	DECKS AND FLOOR PLATES
2-3-7,	WATER TANKS
2-3-8,	FUEL OIL TANKS
2-3-9,	VOIDS AND COFFERDAMS
2-3-10,	CHAIN LOCKER
2-3-11,	BILGES
2-3-12,	INACCESSIBLE SPACES
2-3-13,	SPACES SUBJECT TO HEAVY CONDENSATION
2-3-14,	PIPING
2-3-15,	MACHINERY
2-3-16,	FURNITURE AND EQUIPMENT
2-3-17,	ELECTRIC CABLE
2-3-18,	RADIO AND RADAR ANTENNAS
2-3-19,	ANCHOR CHAIN
2-3-20,	PROPELLERS
2-3-21,	PROPELLER SHAFTING
2-3-22,	WOOD MASTS AND SPARS
2-3-23,	WOOD LADDERS, GANGPLANKS, STAGING AND BOATSWAIN'S CHAIRS

Section	Title
2-3,	COATING SYSTEMS FOR VESSELS
2-3-24,	SMOKE STACKS
2-3-25,	ZINC ANODES
2-3-26,	SONAR DOMES AND TRANSDUCERS
2-3-27,	BRIGHTWORK
2-3-28,	SURFACES REQUIRING ACID RESISTANCE
2-3-29,	SURFACES NOT TO BE PAINTED
2-4,	COATING SYSTEMS FOR STEEL BUOYS
2-4-1,	EXTERIOR OF METAL BUOYS
2-4-2,	INTERIOR OF METAL BUOYS
2-4-3,	METAL BUOYS WITH HIGH LOSS PROBABILITY
2-4-4,	COLOR RENEWAL ON STATION
2-5,	COATING SYSTEMS FOR VEHICLES
2-5-1,	NEW VEHICLES
2-5-2,	REPAINTING OF VEHICLES
2-5-3,	UNDERCOATING
2-6,	COATING SYSTEMS FOR AIRCRAFT
2-6-1,	GENERAL REQUIREMENTS

## SECTION 2-1, INTRODUCTION: COATING SYSTEMS

Protective coating systems generally consist of a layer of two or more different types of paint such as an anticorrosive paint used with an exterior enamel. For any given surface there is a particular combination of types of paints and film thickness of each type which will produce optimum results. Some paints are incompatible with others. It is, therefore, necessary to treat painting from a coating system approach; i.e., one in which the materials, the number of coats of each material and the sequence in which the coats are applied are considered as a unit — the coating system.

While a coating system specifies the materials to be used for particular surfaces, it does not include the color of the material to be used nor does it include complete application instructions or ordering information. Where a question of color is involved, refer to Chapter 3, Color Practice. For ordering information and detailed application instructions, refer to Chapter 4, Materials.

The coating systems contained herein are written for coatings to be applied to properly prepared bare surfaces. The preparation for painting of the various types of surfaces normally encountered in the Coast Guard is discussed in Section 1-5, Surface Preparation.

Where painting is to be done to previously painted surfaces which are in good condition throughout, clean the surface thoroughly by wiping oil and grease spots with Paint Thin-

ner followed by washing the entire surface with Paint Cleaner. Surface irregularities are removed by sanding.

If a previously painted surface shows signs of paint failure, the deteriorated area should be "touched up" by removing the defective paint film down to the bare surface. The edges of adjoining areas of paint film should be sanded to fair the paint film into bare surface. Any surface irregularities will be apparent in the finished paint film. Recoat the bare areas with a complete paint system slightly overlapping onto the old paint. Sandpaper the overlap lightly before each subsequent coat to reduce surface irregularities. After completion of "touch-up" painting, a uniform appearance may be obtained by following with 1 coat of the finish paint over the entire surface. (On exterior wood surfaces 2 coats may be necessary.) When touching up or repainting over previously painted surfaces, be sure that touch-up material is compatible with the old paint. If doubt exists, test by applying a small amount of touch-up material over the old paint in an inconspicuous location.

Various modifications of the above practice may be necessary depending on the type and condition of the surface. In all cases the objective is to cover the entire surface with a dry paint film which is the equivalent of the recommended coating system.



## SECTION 2-2

# COATING SYSTEMS FOR SHORE ESTABLISHMENTS

### 2-2-1, WOOD SURFACES

#### (A) EXTERIOR WOOD, GENERAL

New exterior wood in general such as the exterior of wood buildings, trim, shutters, doors, balustrades, porch ceilings and posts, stair risers, guard rails, hand rails, fences, gates, lampposts, towers, water tanks, and similar surfaces shall receive the following paint system:

(a) Prepare the surface. Seal knots and resin pockets as necessary with Ready-Mixed Aluminum Paint.

(b) Apply 1 coat Exterior Wood White Primer.

(c) Apply 2 coats Exterior Oil Paint, General Purpose. (*In areas where discoloration occurs due to gases in atmosphere, such as industrial fumes and volcanic fumes, use Exterior Oil Paint, Special Fume-resistant.*)

NOTE: When recoating, apply 2 coats of Exterior Oil Paint. The application of 1 liberal coat of Pretreatment-Wash Primer to all bare wood surfaces (except those surfaces which are to be varnished) not only seals the wood but greatly improves the adherence of the top coats.

#### (B) EXTERIOR FLOORS, DECKS, STEPS, BLEACHERS

(a) Prepare the surface. Seal knots and resin pockets as necessary with Ready-Mixed Aluminum Paint.

(b) Apply 1 coat of Deck and Floor Enamel thinned by the addition of 1 qt. of thinning mixture to each gal. of paint. Thinning mixture is composed of  $\frac{2}{3}$  Boiled Linseed Oil and  $\frac{1}{3}$  Paint Thinner.

(c) Apply 2 coats of Deck and Floor Enamel as received.

#### (C) EXTERIOR WOOD SIGNS

Exterior wood signs of all types including aerial identification platforms shall receive the following paint system:

(a) Prepare the surface. Seal knots and resin pockets with knot sealer (MIL-S-12935), or aluminum paint.

(b) Apply 1 coat Exterior Gloss Enamel thinned by the addition of 1 pt. of Boiled Linseed Oil per gal. of paint.

(c) Apply 2 coats of Exterior Gloss Enamel.

#### (D) WOOD DOCKS, WHARVES, PIERS, RAMPS

Wood pilings, stringers and all structural members of wood docks, wharves and piers shall be pressure treated with Coal Tar Creosote (TT-C-650) prior to installation in accordance with the provisions of the current edition of Federal Specification TT-W-571. For details on standards of wood piling see COMDT. INST. 10321.1. Wood deck planking on docks, wharves and piers shall be treated with Tonalith (Wolman-Salt) in accordance with the current edition of Federal Specifications TT-W-571 and TT-W-573.

In cases where deck planking on docks has been previously painted, painting shall be continued, using the following system:

(a) Prepare the surface.

(b) Apply 1 coat of Deck and Floor Enamel thinned by the addition of 1 pt. of Boiled Linseed Oil to each gal. of paint.

(c) Apply 1 coat of Deck and Floor Enamel as received.

#### (E) CREOSOTED WOOD

Creosoted wood when required to be painted, such as supporting members of water tanks, shall be given the following paint system after aging for 6 months:

- (a) Clean the surface. Remove dirt, oil.
- (b) Apply 2 coats Aluminum Paint.
- (c) Apply 2 coats Exterior Gloss Enamel.

#### (F) PREVIOUSLY STAINED WOOD SHINGLES AND SIDING

Wood shingle roofs shall be maintained by staining. Wood shingle siding may also continue to be stained. However, when stained wood siding is to be painted, the surface shall first be given 1 coat of Aluminum Paint to seal in the stain. Finish Material shall have 2 coats of Exterior Oil Paint.

#### (G) INTERIOR WOOD WALLS AND WOOD WAINSCOTING

- (a) Prepare the surface.
- (b) Apply Enamel Undercoat. (Bare wood only.)
- (c) Apply 2 coats Flat Alkyd Paint, Federal Specification TT-P-30.

#### (H) INTERIOR WOOD TRIM

Interior wood trim including doors, door trim, windows, window trim, baseboards, molding, stair risers and balustrades, cabinets and built-in furniture which is to be painted shall be painted according to the following system:

- (a) Prepare the surface.
- (b) Seal knots and resin pockets with 1 coat of Aluminum Paint.
- (c) Apply 1 coat Interior White Enamel Undercoat as received.
- (d) Apply 1 coat Interior Gloss Enamel.

#### (I) INTERIOR WOOD FLOORS

Finished Floors —

New interior wood floors and stair treads that are to receive a natural finish shall be machine sanded to a smooth even surface and swept clean of dust. Open grain woods such as oak, chestnut, and ash require a filler coat. Omit the filler for close grain woods such

as pine, fir, maple and birch. Use transparent Paste Wood Filler thinned to brushing consistency with Paint Thinner. Apply a thick coat and rub it into the wood with a stiff bristle brush. After about 15 minutes, the excess filler should be removed, wiping across the grain with clean rags or burlap. Finish by wiping with a clean cloth. If filler dries hard before wiping can be accomplished, dampen wiping cloth with Paint Thinner. Care must be exercised not to remove the filler from the pores of the wood. Allow 24 hours drying time before proceeding.

After filler coat has dried, clean all dust from the floor, preferably with a vacuum cleaner. Apply 1 thin coat of Floor Sealer, allow it to dry, and buff it in. This will seal the pores of the wood, help to keep out dirt, and resist stains.

After floors have been filled and sealed, Liquid Floor Wax should be applied. A number of thin coats will be more satisfactory than 1 thick coat, because a heavy coat makes the floor greasy. Each layer of wax should be allowed to dry thoroughly and should be polished before adding the next layer. Finishing a floor in this manner will give an attractive, satin-like sheen to the wood and a finish that will not be greasy, will not mar, scratch, or flake off — one that can be touched up at worn spots or in heavy traffic lanes without completely refinishing the entire floor.

#### Gymnasium Floors —

New Gymnasium floors after being sanded and otherwise prepared for finishing should be given 2 coats of penetrating floor sealer of the lacquer type, followed by painting of floor markings and then followed by 2 coats of lacquer type sealer containing resins to reduce slipperiness. Since some of these materials are not available from Standard Stock, open market purchase is necessary. There are several well-known proprietary brands on the market for this purpose. This treatment produces a surface of good appearance which withstands hard usage, reduces slipperiness and readily permits the renewal of the finish whenever necessary. For application of the material, the directions of the manufacturer should be followed.

## 2-2-1

### Painted Floors —

Interior wood floors and stair treads which are to be painted shall be given the following paint system:

(a) Prepare the surface.

(b) Apply 1 coat of Deck and Floor Enamel thinned by the addition of 1 qt. of thinning mixture to each gal. of paint. Thinning mixture is composed of  $\frac{2}{3}$  Boiled Linseed Oil and  $\frac{1}{3}$  Paint Thinner.

(c) Apply 1 coat of Deck and Floor Enamel as received.

### (J) FURNITURE FINISHING

Natural wood finishing may be described as the application of transparent or semi-transparent coatings to wood with the object of accentuating the grain of the wood to bring out the natural beauty, or changing the color to make a less expensive wood appear to be a costlier type.

Mahogany, walnut, maple, birch, and oak are usually preferred in natural finishes, while softwoods such as fir, pine and cypress may be either finished natural or stained to resemble more expensive woods.

Furniture finishes may be either varnish or lacquer finishes, but lacquer is recommended for Coast Guard use. It dries dust free in a very short time (10 minutes). Rubbing or sanding between coats is necessary for best results. As each succeeding coat is applied it dissolves into the preceding coat and forms one continuous film from filler to finish coat.

The methods and materials of wood finishing are as numerous and varied as the finishes desired. Due to limited space, only one standard method is discussed.

#### Surface Preparation —

New wood will require very little surface preparation other than sanding. Use No. 3/0 or 4/0 sandpaper on a block of wood and sand with the grain. Remove all pencil marks, finger prints, etc. Sand until the surface is clean, smooth, and free of scratches. In the case of previously painted or varnished surfaces, the old finish must be completely removed in order to obtain a good new job. Follow directions as outlined in Article 1-5-4

(D), Use of Paint Remover. After the old finish is removed, treat the surface as outlined for new wood.

Nail or screw holes should be filled with Plastic Wood colored to match the desired finish since this material cannot be stained after it has hardened. When applying Plastic Wood, do not strike it off flush with the surface because it shrinks slightly upon drying. Leave a slight hump and sand it down smooth after it has hardened. Remove all dust from the surface and pores of the wood immediately before applying the stain coat by wiping with a "tack rag." (Tack rags are resin impregnated cloths made to pick up lint and dust and may be purchased on the open market.) Dampen the floor to reduce dust.

#### Stain Coat —

Stain application by the brushing method is common procedure and gives best results. A flat type, fine bristle brush is used. First apply stain to a sample of the wood to be stained. This is important because a stain will give a different result on different types of wood. For example, a walnut stain will produce a rich brown color on gum, while the same stain on white pine, basswood or poplar would appear nearly black. Non-grain raising stains shall be used whenever staining is to be done. Stains must dry thoroughly before proceeding. The application of a second coat may be necessary to obtain the desired color. Non-grain raising stains dry to permit filling 1 hour after application.

#### Filler Coat —

Paste Wood Filler is used to fill the open pores of wood surfaces to prevent undue absorption of lacquer by the wood. Filler is applied following complete drying of stain coat. For natural finish, omit the stain coat and apply Wood Filler directly to the wood.

Paste Wood Filler is thinned with Paint Thinner and applied by brushing across the grain. The filler is allowed to "flatten out" which is characterized by a surface drying appearance, after which it is wiped into the pores with a pad made of burlap or clean rags. A circular motion is used to insure filling the pores. The excess is cleaned from

the surface with a clean rag wiping across the grain. If filler sets up too hard for easy wiping, moisten the wiping rag with Paint Thinner. If the wiping is accomplished too soon, the filler will be pulled from the pores and the object will not be accomplished. After wiping clean, the filler is allowed to dry for 24 hours, after which the first coat of lacquer is applied.

#### Lacquer Coats —

Two coats of clear gloss lacquer shall be applied by spray as received in the can. Follow with 1 coat of clear flat lacquer. Sanding is recommended between coats. The flat last coat will greatly reduce the rubbing required to produce the desired luster. If flat lacquer is not available, clear lacquer may be used for this third coat. Allow 2 hours drying time between coats and at least 24 hours on last coat before rubbing. *Lacquer should be sprayed if possible.* If spray equipment is not available, a lacquer formulated especially for brushing must be used. Since the solvents used in lacquers are of a high solvent power, there is a tendency, when applying second and third coats, to lift previously applied coats. To overcome this do not brush out the lacquer as is done with varnish. Use as few strokes as possible to apply a thin even film and then allow the flowing and leveling properties of the lacquer to give you a mirror-like finish. Do not attempt to apply lacquer on a humid day since it may blush, causing the transparent film to become cloudy or opaque.

#### Rubbing —

The rubbing medium recommended is pumice stone and water. A felt pad about  $\frac{1}{2}$  in. thick, 2 in. wide and 4 in. long is used. This felt is mounted on a wood block with the ends turned and securely tacked in place. The rubbing pad should be thoroughly wet when in use.

Rubbing is executed with the grain. Straight and even strokes with the same exerted pressure throughout the stroke are desired. Care must be exercised on corners and edges that the rubbing does not cut through the coating. After rubbing to desired sheen, wash all pumice stone off the surface with clear water and dry with a clean cloth. When dry,

the surface should be polished with furniture polish or wax.

To summarize the above, the finishing system is as follows:

- (a) Prepare the surface.
- (b) Apply non-grain raising stain. (Omit stain if natural finish is desired.)
- (c) Apply 1 coat Paste Wood Filler. (Omit wood filler on close grain woods.)
- (d) Apply 2 coats clear gloss lacquer.
- (e) Apply 1 coat clear flat lacquer.
- (f) Rub and polish.

It will be noted that some of the specified materials for furniture finishing are not available from Standard Stock. As previously stated, the open market purchase of paint materials in general is prohibited. However, the open market purchase of the specified furniture materials is permissible. When procuring lacquers it is recommended that an acid, alcohol, and alkali-resistant type be used.

### (K) REPAIRING FURNITURE FINISHES

Repairing scratches and other damage to furniture finishes is not a difficult job. It will be noted that the quantities of materials needed are small.

There are two methods of patching damaged furniture finishes. "Burning-in" is the name given to the application of melted stick shellac to scratches and other indentations by means of a heated knife. "French polishing" is the application of a surface coating of refined and dewaxed shellac (French Polish) by rubbing with a cloth pad. These methods may be used independently or in conjunction depending upon the extent of the damage.

#### Burning-In —

Stick shellac is available in about seventy-five different colors, making it easy to match almost any finish. Use a translucent stick of the right color for shallow scratches where the stain color is intact. Use an opaque stick of the right color for deep scratches which go down to the bare wood.

To avoid the danger of burning the adjacent surface, the scratch should be masked with masking tape or cellulose tape.

## 2-2-1

The burning-in knife should be of flexible steel, ground square at the end. A kitchen paring knife makes an excellent tool when ground to shape. The knife is held in the flame of an alcohol lamp, the end of the blade being about an inch beyond the flame. The stick shellac is held in contact with the end of the knife, the shellac melting and running onto the knife. As soon as a sufficient quantity is melted to fill the scratch, the knife is removed from the flame and quickly drawn along the scratch to deposit the shellac.

After the masking tape is removed, the ridge of shellac is scraped down with a razor blade. When the patch is as level as the scraper can make it, take a small piece (about  $\frac{1}{8}$  sheet) of 6/0 finishing paper and back it with a small felt pad, or fold it in thirds and back it with the fingers. Dip the paper in alcohol and then in rubbing oil or water. Rub the patch quickly and firmly. Beware of rubbing through the finish around the patch. Dull the patch by rubbing lightly with 3/0 steel wool and the job is done.

Despite care in selecting the stick shellac color, you may find the patch a bit off color. In this case, mix a little alcohol soluble stain and apply it to the patch with a small water-color brush. Selection of the stick shellac color should lean toward a slightly lighter color rather than a darker one. The light shellac can always be stained dark, but dark shellac cannot be stained light.

If the finish around the patch is made thin by rubbing, or if the finish is worn in spots, it can be brought back by spraying a coat of clear flat lacquer on the spot, feathering the edges. If the scratch repaired with stick shellac is to be sprayed, water and not oil should be used for rubbing. After spraying spots, the entire surface must be rubbed with pumice and rubbing oil.

### (L) WOOD WINDOWS AND DOORS

Sliding surfaces of wood double-hung windows shall not be painted but shall be given 2 coats of Boiled Linseed Oil after fitting. Painting these surfaces will cause sticking and binding of the sash. Unsealed surfaces will swell in damp weather and cause the sash to bind.

All edges of wood doors shall be given the same treatment prescribed for the remainder

of the door. Particular attention should be given to top and bottom edges where end grain of the wood is exposed, to avoid swelling and subsequent binding of the door in damp weather.

## 2-2-2, METAL SURFACES

The following paint systems are designed to be applied to properly prepared bare metal surfaces. Methods of surface preparation for the various metals are discussed in the following articles:

- 1-5-1, Preparation of Metal Surfaces (Except Aluminum and Galvanized Steel).
- 1-5-2, Preparation of Aluminum Surfaces.
- 1-5-3, Preparation of Galvanized Steel Surfaces.

### (A) EXTERIOR UNGALVANIZED STEEL

Ungalvanized steel, except those surfaces to receive special treatment, as set forth in subsequent paragraphs, shall be painted as follows:

- (a) Prepare surface.
- (b) Apply 1 liberal coat of Pretreatment-Wash Primer.
- (c) Apply 2 coats of Quick Drying Red Lead Primer.
- (d) Apply 2 coats of Exterior Gloss Enamel. (Total paint film thickness should be over 6 mils.)

### (B) EXTERIOR GALVANIZED STEEL AND CORROSION-RESISTING METALS OTHER THAN ALUMINUM

Galvanized steel, corrosion-resisting steel, nickel-copper alloy, brass and other corrosion-resisting metals, except aluminum or those surfaces to receive special treatment as set forth in subsequent paragraphs, shall be painted as follows:

- (a) Prepare surface.
- (b) Apply 1 liberal coat of Pretreatment-Wash Primer.
- (c) Apply 1 coat of Zinc Chromate Alkyd Primer.
- (d) Apply 2 coats of Exterior Gloss Alkyd Enamel.



**(C) EXTERIOR ALUMINUM**

Exterior aluminum surfaces which are to be painted shall be treated as follows:

- (a) Prepare surface.
- (b) Apply 1 liberal coat of Pretreatment-Wash Primer.
- (c) Apply 1 coat of Yellow Zinc Chromate, Alkyd Type (TT-P-645).
- (d) Apply 2 coats of Exterior Gloss Enamel.

Aluminum shall be protected from contact with dissimilar metal by use of vinyl tape or the following Navy standard stock item as appropriate: Calking Compound, Oil Type, for Metal Seams and Airports (MIL-C-18969).

Watertight joints between aluminum parts shall be made tight by metal calking compound or vinyl tape.

Threaded parts of aluminum shall be coated, before assembly, with an antiseize mixture of 50% zinc dust and 50% petrolatum by volume.

**(D) INTERIOR UNGALVANIZED STEEL**

Interior ungalvanized steel, except those surfaces to receive special treatment as set forth in subsequent paragraphs, shall be painted as follows:

- (a) Prepare surface.
- (b) Apply 2 liberal coats of Pretreatment-Wash Primer.
- (c) Apply 1 coat of Interior Gloss Enamel, Federal Specification TT-E-506.

**(E) INTERIOR GALVANIZED STEEL AND CORROSION-RESISTING METALS**

Interior galvanized steel, corrosion-resisting steel, nickel-copper alloy, brass, aluminum and other corrosion-resisting metals, except those surfaces not to be painted or to receive special treatment as set forth in subsequent paragraphs, shall be painted as follows:

- (a) Prepare surface.
- (b) Apply 1 liberal coat of Pretreatment-Wash Primer.
- (c) Apply 1 coat of Interior Gloss Enamel. (In some cases 2 coats will be necessary to hide the primer.)

**(F) GUTTERS, DOWNSPOUTS AND FLASHING**

Gutters, downspouts, flashing, roof valleys, roof ridges and similar galvanized, copper bronze sheet, or aluminum metal surfaces built into or forming part of roofs or walls, if painted, shall be painted as follows:

- (a) Prepare surface.
- (b) Apply 1 liberal coat of Pretreatment-Wash Primer.
- (c) Apply 1 coat of Zinc Chromate Alkyd Primer.
- (d) Apply 2 coats of the finish material used on adjoining surfaces.

**(G) FURNITURE AND EQUIPMENT**

Metal (except aluminum) furniture, steel doors, switch boxes, controllers, switchboards, connection boxes, galley equipment, and miscellaneous equipment in general shall be painted in accordance with the following system:

- (a) Prepare surface.
- (b) Apply 1 liberal coat of Pretreatment-Wash Primer.
- (c) Apply 2 coats Equipment Enamel.

Aluminum furniture and interior aluminum equipment shall not be painted but shall be kept bright.

**(H) MACHINERY, SHORE UNITS**

Interior Machinery —

Uninsulated, ungalvanized metal surfaces, the operating temperatures of which are 300° F. or less, shall be painted according to the following system:

- (a) Prepare the surface.
- (b) Apply 1 liberal coat of Pretreatment-Wash Primer.
- (c) Apply 1 coat of Quick Drying Red Lead Primer.
- (d) Apply 2 coats of Gloss Enamel, Gray.

Uninsulated galvanized steel, corrosion-resisting steel, nickel-copper alloy or other corrosion-resisting surfaces, the operating temperatures of which are 300° F. or less, shall be painted according to the following systems:

- (a) Prepare surface.
- (b) Apply 1 liberal coat of Pretreatment-Wash Primer.

## 2-2-2

(c) Apply 2 coats of Gloss Enamel, Gray.

Uninsulated metallic surfaces, the operating temperature of which exceeds 300° F., shall be thoroughly cleaned and coated with 2 coats of Heat-Resisting Paint.

Fabric covered insulation or rough surfaces finished off with Smoothing Cement shall be given 2 coats of Gloss Enamel, Gray. Aluminum surfaces are not to be painted but shall be kept bright.

### Exterior Machinery —

The painting system for exterior machinery depends upon the metal used and shall be the same as that specified for general exterior use of the metal.

#### (I) METAL TRAFFIC AREAS

Metal ladders, catwalks, decks, etc. shall be given the coating system prescribed for the particular metal and exposure conditions under consideration, described in Articles 2-2-2(A) through 2-2-2(E), except that the finish coat shall be 2 coats of Deck and Floor Enamel in lieu of the regularly specified finish coat. Non-skid properties may be added to the Deck and Floor Enamel by sweeping washed beach sand on the surface while it is tacky. Sweep the sand well into the paint, allow to dry and sweep off loose sand particles. A final coat of Deck and Floor Enamel, thinned by the addition of 1 pt. of paint thinner per gal. of paint should then be applied over the sand.

#### (J) WATERFRONT AND UNDERGROUND METAL SURFACES

Underground metal piping, interior of floating drydocks, bulkheads, piers, offshore light stations, shall be coated and recoated as necessary with specialized coatings as originally specified unless directed otherwise. The coatings and types of structures are as follows:

Sheet and H beam piling	(I)
Offshore fixed steel structures	(I plus IV, or IV)
Offshore light station (fuel storage tanks)	(III)
Steel light structures	(I plus IV, or IV)
Underwater erosion and corrosion control	(I)
Dissimilar metal junctions	(I)
Interior steel insulation	(II)

#### Potable water tanks (interior) (VI)

NOTE: Roman numerals in parentheses refer to the coatings listed below and indicate the authorized system for use.

(I) Coal tar-epoxy, TARSET or Coast Guard approved equivalent.

(II) Mastic, fire retardant, Insulmastic 553, FR, or Coast Guard approved equivalent.

(III) Epoxy, 3 coat system, Devran 203.

(IV) Epoxy, 2 component coating, Devran 209.

(V) Epoxy primer, Devran 202, polyamide cured, 2 component coating for use with either Formula 203 or 209, or as a primer under coal tar-epoxy when specified.

(VI) Epoxy, 2 component coating, Devran 207; similar to other epoxies but has been approved by Public Health Service for use in potable water tanks. This water tank system consists of 3 coats of contrasting colors, the first of which is considered the primer.

In the case of piers, piling, bulkheads and other partially submerged structures, the economic feasibility of utilizing cathodic protection to protect the underwater surfaces should be investigated.

#### (K) HOT SURFACES

Hot surfaces (operating temperature above 300° F.) such as boiler fronts, heating furnaces, smoke pipes, hot piping, hot water tanks and hot water heaters shall be given the following paint system:

(a) Prepare surface.

(b) Apply 2 coats of Heat-Resisting Paint.

Where the surface is insulated, Heat-Resisting Paint shall not be used unless the outer surface of the insulation is above 300° F. See Article 2-2-2(H) for surfaces under 300° F.

#### (L) STEEL WATER TANKS (INTERIOR SURFACES)

(a) Zinc Dust paint system. Feed water tanks and potable water tanks shall be painted with 2 coats of Zinc Dust Paint, over bare metal. Pretreatment-Wash Primer shall not be used under the Zinc Dust Paint.

To apply the Zinc Dust Paint remove all former paint coatings by sandblasting, if

possible; power wirebrushing may be used where sandblasting is impractical. Following the cleaning and prior to painting, the Engineer Officer shall inspect the tank to insure that all dirt, sand and rags have been removed from the tank bottom, longitudinal frames and stringers, sounding tubes, vents, filling connections and suction. Apply first coat of Zinc Dust Paint. Following the first coat of Zinc Dust Paint, unheated air shall be circulated through the tank for 12 hours. The second coat shall then be applied and unheated air circulated through the tank for 12 hours. Tanks shall then be disinfected in accordance with current directives on Shipboard Water Purity.

**CAUTION:** Only enough Zinc Dust Paint shall be mixed for daily use. Mixed Zinc Dust Paint shall not be stored. After the material is mixed, a gas pressure may build up within closed containers.

(b) Epoxy system. Feed water or potable water tanks other than structures previously classified may, at the discretion of the District Commander, be painted with the Devran 207 system.

#### (M) INTERIOR OF STEEL FUEL AND LUBE OIL TANKS

The interior of steel tanks, such as fuel oil tanks, lube oil tanks and lube oil reservoirs, shall be left uncoated except for the oil film. When lube oil tanks or lube oil reservoirs are to be left empty for 30 days or more, the surface shall be coated with Thin-Film Rust Preventive, Grade II. When returning tanks to service, the preservative shall be removed in accordance with the instructions set forth in BuShips Technical Manual, Chapter 9.

Certain offshore light station fuel storage tanks are designed also to serve as basic structural members. The original construction contract requires the interior surfaces of these tanks to be painted with three coats of epoxy (Devran), the final coat to be white. Steel repair work on the inside of these tanks should be coated with the same system.\*

#### (N) INTERIOR PIPING

Metallic piping which is to be insulated shall be given 1 liberal coat of Pretreatment-Wash

Primer and 1 coat of Quick Drying Red Lead Primer on the exterior surface of the pipe. The fabric-covered insulation shall be given 2 coats of the same material used on adjoining surfaces.

Uninsulated pipe shall be given the same paint system as that prescribed for similar surfaces.

Where the normal operating temperature of the piping exceeds 300° F., 2 coats of Heat-Resisting Paint shall be used in lieu of the conventional system.

#### (O) FLAMMABLE LIQUID STORAGE TANKS

The exterior of large flammable liquid storage tanks shall normally be painted in accordance with Article 2-2-2(A). In tropical and semi-tropical areas such tanks may, at the discretion of the responsible District, be painted aluminum to reduce heat absorption. The aluminum system shall be as follows:

(a) Prepare surface by removing all rust and loose paint. Old, tightly adhering paint may be left on.

(b) Immediately apply 1 liberal coat of Pretreatment-Wash Primer to bare metal areas.

(c) Apply 2 coats of Yellow Zinc Chromate, Alkyd Type, to previously bare areas, then 1 more complete coat as a tie-coat for aluminum.

(d) Apply 2 coats of ready-mixed aluminum paint, Federal Specification TT-P-38.

NOTE: The complete zinc chromate tie-coat may be omitted when repainting tanks previously painted aluminum.

#### 2-2-3, MASONRY SURFACES

The type of paint used on masonry surfaces depends primarily upon whether the masonry is in a damp or dry location. Methods of cleaning, repairing, and pretreatment of masonry surfaces in preparation for painting are discussed in Article 1-5-5, Preparation for Masonry Surfaces.

#### (A) EXTERIOR WALLS ABOVE GRADE

The following system shall be used whenever the painting of exterior masonry walls is accomplished. The types of surfaces includes brick, stone, stucco, cement aggregate, cement-

\* EPOXY CONFORMING TO Chap. 2, Page 11  
MIL-C-23236, CLASS 1.

## 2-2-3

asbestos shingles and cinder block aggregate.

(a) Prepare the surface. Remove loosely adhering paint, chalk, and/or effluorescence from previously painted surfaces by scraping, wirebrushing or sandblasting. Sandblasting is the most effective method if the equipment is available. No wetting or dampening of the surface with water is necessary before application of the paint unless the atmosphere temperature is particularly high (90° F. or above).

(b) Directly apply two coats of acrylic emulsion paint, preferably by spray, to any of the surfaces listed in (A) with the exception of cinder block. See paragraph (c). Application by brush or roller is also acceptable. The acrylic emulsion paint will not perform satisfactorily over a chalky surface. If conditions prohibit complete removal of chalk, a primer-sealant conforming to MIL-V-1174 and slightly thinned with mineral spirits should be applied.

(c) On roughly textured surfaces such as cinder block, a fill coat or grout coat using formula below is applied prior to the application of the acrylic emulsion paint. The following formula shall prevail:

### FORMULA

White Portland Cement (SS-C-192, I or II Type)	16.5 lbs.
Washed Silica (30-50 mesh)	33.5 lbs.
Potable water	1.5 gals.
Acrylic emulsion paint of finish color	1.75 gals.

The above formula should be mixed in the following sequence: Cement and silica shall be dry-mixed so that uniform distribution and intermixing are obtained. Add 1 gal. of water gradually, stirring until homogeneous. To avoid excessive foaming and air entrapment, the mixture should not be agitated too vigorously. Add the exterior emulsion paint to the cement-silica slurry and stir until uniform. Add additional water to obtain a blend having a thick, creamy consistency if necessary.

NOTE: The above formula replaces paragraph 3.5, "Surface Preparation," contained in Specification TT-P-0019 (ARMY-CE), Acrylic Emulsion Paint.

## (B) EXTERIOR WALLS BELOW GRADE

### New Construction —

The exterior of masonry basement walls below grade which are subject to water penetration shall be waterproofed with a built-up membrane of felt and bituminous compounds constructed in accordance with Bureau of Yards and Docks Specification No. 7YJ.

In dry locations or where excellent soil drainage exists, dampproofing may be accomplished by the application of 2 coats of acrylic emulsion.

### Old Construction —

In most cases, it is impractical to excavate around buried walls for the purpose of waterproofing. Where seepage or leaks occur in basement walls, the causes should be located and rectified before attempting any type of waterproofing. Broken gutters and downspouts and a grade slope toward the building are invitations to leaky basements. Repair all cracks and loose mortar joints in the wall above grade. Treat interior of basement as discussed in paragraph (D) following.

## (C) INTERIOR WALLS ABOVE GRADE

### New Plaster —

New interior plaster shall be allowed to age at least 2 weeks and then painted as follows:

- (a) Prepare the surface.
- (b) Apply 2 coats Interior Latex Paint.

Where a glossy paint or a paint with extremely high washability is required, as for sanitary spaces, allow new plaster to age at least 1 month, 6 months if possible, and paint as follows:

- (a) Prepare the surface.
- (b) Apply 1 coat Interior Wall Primer Sealer.
- (c) Apply 1 coat Interior White Enamel Undercoat.
- (d) Apply 1 coat Interior Gloss Enamel.

### Interior Surfaces Other Than Plaster —

Extremely porous masonry, such as cinder block, shall be sealed (aging not necessary) with 1 fill or grout coat using the formula described in Article 2-2-3A(c). Follow with 1 coat of Acrylic Emulsion Paint. New masonry shall be allowed to age at least 2

weeks before the application of the below coating system. Previously painted masonry and wall board may be painted without aging.

(a) Prepare the surface.

(b) Apply 2 coats Acrylic Emulsion Paint.

(In sanitary spaces, apply 1 coat Interior White Enamel Undercoat followed by 1 coat Interior Gloss Enamel.)

#### (D) INTERIOR WALLS BELOW GRADE

Unpainted Basement Walls —

Unpainted basement walls shall be treated as follows.

(a) Prepare the surface.

(b) Apply 2 coats Acrylic Emulsion Paint. (Where dampness is present, rectify possible causes of dampness.)

Previously Painted Basement Walls —

Previously painted basement walls which remain dry shall be treated as follows:

(a) Prepare the surface.

(b) Apply 1 coat Acrylic Emulsion Paint.

#### (E) CONCRETE FLOORS BOTH ABOVE AND BELOW GRADE

Concrete floors shall not normally be painted.

#### (F) MASONRY SWIMMING POOLS

New concrete swimming pools shall age for at least 2 months before painting. The pool shall be filled with water during this period in order that the water-soluble salts will be leached out, thus eliminating subsequent blistering of the paint. Any grease or oil spots should be washed with a strong alkaline cleaner and rinsed. New swimming pools with hard slick surfaces should be acid etched by applying a mixture of 1 gal. of 36 per cent muriatic acid (hydrochloric) added to 3 gals. of water (1 gal. to 100 sq. ft.). After 15 minutes, hose off the acid thoroughly and allow to dry. Apply 3 coats of Paint, Rubber Base (For Swimming Pools), Federal Specification TT-P-95. The first coat shall be thinned with 1 part Xylene to 4 parts paint (by volume) and thoroughly brushed into the pores. The second and third coats shall be applied as received so as to present a surface free of pin-holes and other imperfections.

While the paint dries tack free within 1 hour, 48 hours drying time is recommended between coats. If the swimming pool is in the interior of a building, provide ventilation while applying paint and during drying time. If it is necessary to spray the final coat to insure a continuous film, it should be thinned to spraying consistency with Synthetic Enamel Thinner. The paint shall be allowed to dry for at least 7 days before filling the swimming pool with water.

While this paint is intended primarily for painting concrete swimming pools, it may also be used for interior and exterior masonry surfaces which are exposed to water, water vapor, or other severe conditions of moisture. Such structures may include shower rooms, water plants, reservoirs, filter basins, laundries, etc. It is not intended for use over conventional oleoresinous paint.

#### 2-2-4, COATING SYSTEM FOR DRY WALL CONSTRUCTION

All types of dry wall construction including sheetrock, gypsum board, fiberboard, prestwood, acoustical tile, etc., shall be given the following paint system:

(a) Clean the surface.

(b) Apply 1 coat of Interior Synthetic Rubber Emulsion Paint to seams preliminary to the overall coat, or apply 1 coat Latex Primer, Interior for Gypsum Wallboard, Federal Specification TT-P-650.

(c) Apply 1 overall coat of Interior Synthetic Rubber Emulsion Paint.

NOTE: On acoustical tile, apply the paint in a thin coat and brush it out to avoid bridging and clogging of the pores. A small amount of thinning with water is permissible if clogging of pores is experienced. Frequent repainting of acoustical tile should be avoided.

In sanitary spaces where a glossy paint is required with high scrubability, the following system shall be used.

(a) Clean the surface.

(b) Apply 1 coat of Interior Wall Primer-Sealer.

(c) Apply 1 coat of Interior White Enamel Undercoat.

(d) Apply 1 coat Interior Gloss Enamel.

## 2-2-5

### 2-2-5, COATING SYSTEMS FOR ROOFS

#### (A) WOOD ROOFS

Wood roofs shall be painted according to the following system:

- (a) Clean the surface.
- (b) Apply 1 coat Exterior White Wood Primer.
- (c) Apply 2 coats Tile Red Roof Paint.

#### (B) METAL ROOFS

Metal roofs shall be painted according to the following system:

- (a) Prepare the surface.
- (b) Apply 1 coat Pretreatment-Wash Primer.
- (c) Apply 1 coat Quick Drying Red Lead Primer.
- (d) Apply 2 coats Tile Red Roof Paint.

NOTE: Where roofs are used for drinking water, catchments, step (c) shall be omitted and 2 coats Exterior Gloss Enamel applied.

#### (C) COMPOSITION SHINGLE ROOFS

Composition shingle roofs on new construction should match the color of Tile Red Roof Paint as nearly as possible. Composition shingle roofs shall not be painted.

#### (D) SLATE ROOFS

Slate roofs shall not be painted.

### 2-2-6, WOOD WATER TANKS

Neither the interior nor exterior of wood water tanks shall be painted. Discoloration of water in new Redwood tanks can be avoided by adding Sal Soda to the first filling. Use 2 pounds of Sal Soda for each 1000 gals. of water. Dissolve the Sal Soda in a bucket of hot water and add the mixture to the tank as it is being filled to insure uniform dispersion of the mixture. Keep the Sal Soda in the tank for 2 days. Drain and rinse the tank prior to use.

### 2-2-7, WINDOW AND DOOR SCREEN FRAMES

Window screen frames and screen door frames after priming shall be painted with Trim and Trellis Enamel in the same color as the adjoining window or door trim.

### 2-2-8, INTERIOR OF REFRIGERATION BOXES

Interior surfaces of refrigeration boxes shall be painted according to the following system:

- (a) Clean the surface (surface must be dry and warm).
- (b) Galvanized Metal: Apply 1 liberal coat of Pretreatment-Wash Primer, follow with 1 coat of Zinc Chromate Primer. Wood: Apply 1 coat of Interior White Enamel Undercoat.
- (c) Apply 2 coats Exterior Gloss Enamel.

### 2-2-9, ROAD AND RUNWAY MARKINGS

Road and runway markings may be applied by hand and/or by striping machine. Apply 2 coats of Traffic Paint to dry, clean pavement. Paint Thinner may be used to remove grease and oil from the surface.

### 2-2-10, BRIGHTWORK

Brightwork shall be polished to a shiny surface with metal polish and shall not be painted or coated. Wipe off all polish.

### 2-2-11, SURFACES REQUIRING ACID RESISTANCE

Surfaces in darkrooms, battery lockers and laboratories which require acid-resisting protection shall be given the vinyl paint system specified below. (Applies to battery boxes, cans, racks, etc.)

#### (A) METAL SURFACES

- (a) Prepare the surface.
- (b) Apply 1 coat of Pretreatment-Wash Primer.
- (c) Apply 1 coat of Vinyl Red Lead Primer.
- (d) Apply 2 coats of Vinyl-Alkyd Paint.

#### (B) WOOD SURFACES

- (a) Prepare the surface.
- (b) Apply 1 coat of Wash-Primer.
- (c) Apply 2 coats of Vinyl-Alkyd Paint.

### 2-2-12, SURFACES NOT TO BE PAINTED

It is impractical to enumerate all of the surfaces which are not to be painted at shore establishments. However, the following examples are given as a guide.

## SURFACES NOT TO BE PAINTED

<i>Surface</i>	<i>Treatment</i>
Applicator Nozzles	Polish
Asbestos-Cement Siding	No Coating unless otherwise specified
Bells, Bronze	Polish and coat with clear plastic or lacquer
Boatswain's Chairs	2 coats of Boiled Linseed Oil
Bolts, Threaded Parts Exposed to Weather	Chain, Gear and Wire-Rope Lubricating Grease
Brick Walls	No Coating
Brightwork (all types)	Polish only
Canvas Covers, Removable	No Coating
Cedar Closet Linings	No Coating
Chain, Galvanized	No Coating
Concrete: Walls, Walks, Decks, Roads Previously Unpainted	No Coating unless otherwise directed
Creosoted Wood Where Appearance is not important, such as Telephone Poles, Antenna Masts, Dolphins, etc.	Creosoted only
Fire Hose	No Coating
Fire Hose Nozzles	Polish only
Floors, Industrial Shop, Marble and Terrazzo	No Coating
Floors, Resilient Tile or Linoleum	Waxed
Floor Treads, Non-Skid	No Coating
Gaskets, Rubber, for Joints	No Coating
Gears, Exposed	Chain, Gear and Wire-Rope Lubricating Grease
Glands, Packing	No Coating
Gratings, Wood	2 coats of Boiled Linseed Oil
Grease Cups	No Coating
Hose, All Types	No Coating
Insulators	No Coating
Ladders, Portable, Wood	2 coats of Boiled Linseed Oil
Leather Coverings	Treated with Leather Preservative, Neatsfoot
Mahogany and other fine wood paneling	Treat as before
Markers, U.S. Coast and Geodetic Survey Line Markers	Do not paint or disturb. Protect with guard posts or fence if necessary
Name Plates	No Coating
Oil Cups	No Coating
Oil Holes	No Coating

## SURFACES NOT TO BE PAINTED

<i>Surface</i>	<i>Treatment</i>
Ordnance, Working Parts of	Polished and/or Lubricated
Plaques	No Coating
Plumbing Fixtures, Plated	Polish
Porcelain Enamel Surfaces	No Coating
Spark Proof Floors	No Coating
Stages	2 coats Boiled Linseed Oil
Tile, Asphalt, Rubber, Linoleum, Cork	Waxed
Tile, Ceramic	No Coating
Tree Trunks	No Coating
Valves; stems, glands, threaded and machined parts	No Coating on interior valves. Exterior valves may be coated with Chain, Gear and Wire-Rope Lubricating Grease.





## SECTION 2-3

### COATING SYSTEMS

#### FOR VESSELS

Coating systems are based primarily on the location of the surface and the type of material. The following paint systems are designed to be applied to properly prepared bare surfaces. Methods of surface preparation for the various surfaces encountered are discussed in Section 1-5, Surface Preparation.

#### 2-3-1, PROTECTIVE COATINGS FOR CONSTRUCTION AND MAINTENANCE

##### (A) STEEL VESSELS

Rust and mill scale shall be removed and the steel thoroughly cleaned by acid-pickling, flame-descaling or by an approved blasting process.

Pickling and subsequent cleaning shall be in accordance with the Chapter 9190, Bureau of Ships Technical Manual.

Immediately after cleaning the steel, coat all surfaces with one of the following systems as applicable:

(a) 1 coat of Pretreatment-Wash Primer, followed by 1 coat of Quick Drying Red Lead Primer.

(b) 1 coat of Coal Tar Epoxy, MIL-C-23236.

(c) 1 coat of (Devran) Formula 202 or 208.

NOTE: For coatings (b) and (c) the temperature must be 50° F. or higher.

On steel vessels of welded construction the cleaning and coating with primer may be done either before or after fabricating to the ship's structure. When this treatment is given to the metal prior to its being welded into the ship's structure all welds and burned areas occurring in construction shall be cleaned to

bare metal and touched up with the primer specified.

Where riveted construction is used, apply the applicable system to all faying surfaces prior to assembly.

Interiors of tanks, galvanized steel and metals other than steel shall be treated in accordance with the detailed requirements in subsequent paragraphs.

##### (B) WOODEN BOATS AND DECKS

Wood boats under construction shall have all surfaces, except the wearing surfaces of deck planking and surfaces to be oiled or varnished, treated with Copper Naphthenate Wood Preservative. The treatment shall be applied after the structural members have been assembled and prior to planking or decking. Joints, faying surfaces and butt ends shall be thoroughly drenched and particular care shall be given to these surfaces in the bow and stern of the boat. After being planked and calked the hull planking shall be treated, working as much of the preservative into the seams and calking material as possible. Seams in hull planking shall be finished using either Oil Type Calking Compound or an approved commercial seam compound. Calking compound shall be worked well down into the seams and the seams filled nearly flush (slightly concave) with the surface of the planking to allow for swelling after vessel is waterborne.

Deck planking shall be calked with cotton and oakum. The seams shall be filled almost to overflowing with the wood preservative. Care must be taken immediately to wipe up

## 2-3-2

any preservative which is spilled on the wearing surface of the planking since it will stain. After the preservative has soaked in and allowed to dry, seams are to be payed with Marine Glue or an approved seam compound under MIL-C-18255C (Ships), Wooden Deck Seam Compound, Synthetic Rubber Base.

Countersunk bolt and screw holes in hull and deck planking shall be treated with preservative before plugging. Plugs shall be treated by soaking in the preservative for at least 5 minutes. Butt blocks shall be soaked at least 30 minutes.

### 2-3-2, BOTTOM PAINTING

#### (A) GENERAL

Bottom painting (from keel up to bottom edge of boot-topping or bottom edge of color coat if there is no boot-topping) of steel vessels regularly kept afloat in salt water shall be accomplished in either the Cold Plastic, Vinyl Paint, or Coal Tar Epoxy System at the discretion of the District Commander. However, it is recommended that the paint system applied at time of construction be continued if practical.

\*<sup>1</sup>For painting of sonar domes and transducers see Article 2-3-26, Sonar Domes and Transducers.

The bottoms of steel vessels over 40 ft. in length regularly kept afloat in fresh water shall be painted below the lower edge of the boot-topping with an inorganic zinc silicate coating or coal tar epoxy (see Articles 4-8-3, 4-8-5). Steel boats 40 ft. in length and under shall be painted in the Vinyl System.

#### (B) COLD PLASTIC SYSTEM

- (a) Prepare surface.
- (b) Apply 1 liberal coat of Pretreatment-Wash Primer.
- (c) Apply 3 coats Anti-corrosive Ship-bottom primer, in alternating coats of Formula 14N and 14ND.
- (d) Apply 3 coats of Cold Plastic Antifouling Paint, Formula 105.

NOTE: The only difference between formulas 14N and 14ND is one of color.

\*<sup>1</sup> UNLESS OTHERWISE AUTHORIZED BY COMMANDANT. ---

\*<sup>3</sup> FOR AREAS OF HIGH INDUSTRIAL POLLUTION, TOPCOAT WITH EITHER VINYL OR EPOXY.

#### (C) VINYL SYSTEM

- (a) Prepare surface.
- (b) Apply 1 liberal coat of Pretreatment-Wash Primer (0.5 mils dry film thickness).
- (c) Apply 4 coats Vinyl Red Lead Primer, alternating orange and brown to provide at least 6 mils combined dry film thickness — steps (b) and (c).
- (d) Apply 2 or more coats of Vinyl Antifouling Paint to attain a total dry film thickness of 10 mils — steps (b), (c), and (d).

NOTE: Steel 30-ft. and 40-ft. Utility Boats attached to the Second and Ninth District, omit step (d) above.

#### (D) COAL TAR EPOXY SYSTEM

- (a) Prepare surface.
- (b) Apply 1 coat of Devran 202 or 208 Primer.
- (c) Apply 2 coats of Coal Tar Epoxy to provide a minimum (not average) thickness of 16 mils.
- (d) Apply 3 coats (10 mils minimum) of Cold Plastic Antifouling Paint, Formula 105.\*<sup>2</sup>

#### (E) INORGANIC ZINC SILICATE

- (a) Prepare surface.
- (b) Apply 1 liberal coat of Inorganic Zinc Silicate in strict conformance with the manufacturer's directions.\*<sup>3</sup>

#### (F) WOODEN BOATS

The following instructions apply to the bottom painting of wooden boats regularly kept afloat in salt water. Wooden boats not regularly kept afloat, such as shipboard boats, in launchways at Rescue Stations, shall have their bottoms painted with the same paint system as is prescribed for the hull above the boot-top or waterline.

- (a) Prepare the surface. Treat with Copper Naphthenate Wood Preservative.
- (b) Apply 1 liberal coat of Pretreatment-Wash Primer.
- (c) Apply 2 coats of Vinyl Antifouling Paint.

NOTE: The Pretreatment-Wash Primer serves as a sealer and helps to prevent blistering of the Vinyl Antifouling Paint. The combined system of Copper Naphthenate treated wood with Pretreatment-Wash Primer and

\*<sup>2</sup> OR VINYL ANTIFOULING PAINT, 2 COATS.

Vinyl Antifouling Paint is resistant to marine borer attack.

#### Repainting of Wooden Boats —

Principal growth which will normally be present is grass and algae. These are to be removed by vigorous scrubbing with stiff fiber bristle brush such as a deck scrubber. Remove all oil and grease. Since vinyls are very resistant to alkalies and oils, strong non-abrasive detergent, kerosene or paint thinner may be used. After rinsing and allowing to dry thoroughly, wire brush any areas where paint appears to be peeling, blistering, or loosely adhering. Sand all such rough spots smooth. Examine bottom for marine borer attack. If found, localities or spots of entrance shall be treated by burning with torch or replacing destroyed material as necessary.

(a) Touch up base wood by treating with Copper Naphthenate Wood Preservative and 1 liberal coat of Pretreatment-Wash Primer.

(b) Apply 3 brush coats or 4 spray coats of Vinyl Antifouling Paint.

#### Boats With Sheathed Bottoms —

Boats with metal sheathed bottoms shall have their entire hull, including the area in way of sheathing, treated with Copper Naphthenate Wood Preservative. Copper sheathing of boats regularly kept afloat shall not be painted. Copper sheathing of boats not regularly kept afloat shall have their bottoms painted with the same paint system as is prescribed for the hull above the boot-top or waterline.

Boats sheathed with metal other than copper shall have the sheathing painted as described for bottoms of steel vessels.

Boats sheathed with plastic shall have the sheathing painted with 1 coat of Pretreatment-Wash Primer and 2 coats of Vinyl Antifouling Paint.

#### Marking —

In order readily to identify boats which have vinyl bottom paint, the date of application shall be marked in No. 14 Brilliant Yellow on the starboard quarter not less than 1 ft. below normal waterline.

#### Zincs —

Zincs shall not be used on wooden or plastic boats except where steel is used in shafts, rudders or other important exterior appendages and only when the steel is in vicinity of or coupled to bronze propellers or fittings. The use of zincs reduces the effectiveness of antifouling paints and causes accelerated fouling of bronze and copper materials.

#### Painting Schedule —

All wooden boats regularly kept afloat shall have their underwater bodies repainted with three brush coats or four spray coats of Vinyl Antifouling Paint as follows:

(a) Second and Ninth Coast Guard Districts, once every 2 years.

(b) All other Districts, once each year normally in March or April.

(c) In all Districts other than Second and Ninth, if boat has not been hauled for other reasons and touched up within 6 months after complete bottom painting, the boat shall be hauled for vinyl touch-up prior to being 200 days waterborne.

(d) In all Districts whenever a wood boat is hauled for any reason, bare and abraded areas shall be touched up by first saturating with Copper Naphthenate Wood Preservative then painting with one coat of Pretreatment-Wash Primer and two coats of Vinyl Antifouling Paint.

#### (G) PLASTIC BOATS

Bottom painting of plastic and plastic-sheathed boats regularly kept afloat shall be in the same paint system and at the same frequency as prescribed for wooden boats above, except that Copper Naphthenate shall not be used. For additional information on repair prior to painting see Coast Guard Maintenance and Repair Manual for Coast Guard Plastic Boats, T.P. 1625.

As an optional system for the underwater body of plastic boats, clean and scrub hull and let dry. Apply 2 coats of Formula 105, Cold Plastic Antifouling paint directly on the hull without any primer except as may be recommended by the plastic and/or coating manufacturer.

## 2-3-3

### 2-3-3, BOOT-TOP PAINTING

#### (A) STEEL VESSELS IN SALT WATER — COLD PLASTIC SYSTEM

- (a) Prepare surface.
- (b) Apply one liberal coat of Pretreatment-Wash Primer.
- (c) Apply three coats Anticorrosive Ship-bottom Primer in alternating coats of Formula 14N and 14ND.

(d) Apply three coats Cold Plastic Antifouling Paint. Use Formula 146/50, Black, for white hulled vessels. Use Formula 105, Red, for black hulled vessels.

#### (B) STEEL VESSELS IN SALT WATER — VINYL SYSTEM

- (a) Prepare surface.
- (b) Apply one liberal coat Pretreatment-Wash Primer.
- (c) Apply four coats Vinyl Red Lead Primer.
- (d) Apply three coats Vinyl Antifouling Paint. Use Formula 129, Black, MIL-P-16189, for white hulled vessels. Use Coast Guard Enamel, for black hulled vessels.

NOTE: No intermixing of Vinyl and Cold Plastic Systems for underwater body areas and boot-topping areas shall be permitted. Hence, the system selected shall be carried from the keel to the upper edge of the boot-topping.

#### (C) STEEL VESSELS IN SALT OR FRESH WATER — COAL TAR EPOXY SYSTEM

- (a) Prepare surface.
- (b) Apply one coat of Devran 202 or 208 Primer.
- (c) Apply two coats of Coal Tar Epoxy (16 mils minimum).
- (d) Apply three coats of Cold Plastic Antifouling Paint. Use Formula 146/50, Black, for white hulled vessels. Use Formula 105, Red, for black hulled vessels.

#### (D) STEEL VESSELS IN FRESH WATER — INORGANIC ZINC SILICATE SYSTEM

(a) Prepare surface in accordance with manufacturer's instructions.

(b) Apply 1 liberal coat of Inorganic Zinc Silicate.

(c) Apply 1 coat Devran 202.

(d) Apply 1 coat Devran 209; black for white hulled vessels; red for black hulled vessels.

NOTE: For areas of high industrial pollution, the coal tar epoxy system is recommended.

#### (E) WOODEN BOATS

These instructions apply to the painting of boot-topping areas on wooden boats regularly kept afloat. Wooden boats not regularly kept afloat shall have their boot-topping painted with same system as prescribed for the hull above the boot-topping.

(a) Prepare the surface. Treat with Copper Naphthenate Wood Preservative.

(b) Apply one liberal coat Pretreatment-Wash Primer.

(c) Apply two coats Vinyl Antifouling Paint (Red or Black commensurate with the hull color scheme).

### 2-3-4, EXTERIOR OF VESSELS ABOVE THE BOOT-TOP

#### (A) EXTERIOR STEEL — GENERAL

Ungalvanized steel, except those surfaces to receive special treatments as set forth in subsection paragraphs, shall be painted as follows:

(a) Prepare the surface.

(b) Apply one liberal coat of Pretreatment-Wash Primer.

(c) Apply three coats of Quick-Drying Red Lead Primer.

(d) Apply two coats of Exterior Gloss Enamel.

NOTE: For exterior galvanized steel and corrosion-resisting metals other than aluminum, utilize the same system except apply only two coats of Quick-Drying Red Lead Primer in step (c) above.

#### (B) EXTERIOR STEEL — VINYL

Steel vessels and boats 95 feet in length and under shall be painted as follows:

(a) Prepare surface.

(b) Apply one liberal coat of Pretreatment-Wash Primer.

(c) Apply four coats of Vinyl Red Lead Primer.

(d) Apply two coats of Vinyl Alkyd Paint.

#### (C) EXTERIOR STEEL — EPOXY

Those vessels with epoxy systems applied at time of construction, should continue this system if practical. Otherwise use Vinyl Alkyd on superstructure.

#### (D) EXTERIOR ALUMINUM

Exterior aluminum surfaces shall be painted as follows:

(a) Prepare the surface.

(b) Apply one liberal coat of Pretreatment-Wash Primer.

(c) Apply two coats of Yellow Zinc Chromate, Alkyd Type.

(d) Apply two coats Exterior Gloss Enamel.

The following procedure shall be used for isolating aluminum to steel faying surfaces exposed to weather:

(1) The steel coaming shall be sandblasted to clean metal and one coat of Coal Tar Epoxy shall be applied in a band one inch wider than the overlap of aluminum. The Coal Tar Epoxy shall be allowed to cure before installing the aluminum.

(2) The aluminum faying surface shall be coated with PRC seam compound (PR-391-HT) and left to cure.

(3) At assembly of the joint, apply a coat of PRC (PR-391-HT) to the Coal Tar Epoxy on the steel coaming and assemble the joint, wiping off the excess PRC compound from the weather side of the joint.

(4) After curing apply another coat of Coal Tar Epoxy to the coaming, including three inches of the aluminum deckhouse.

For protection of wood-to-aluminum joints use Calking Compound, for metal and wood enclosures, MIL-C-18969.

Watertight joints between aluminum parts shall be made tight by metal calking rather than the use of gaskets or packing.

Wood in contact with aluminum shall be given one coat of Spar Varnish, prior to assembly.

Asbestos paper or similar absorbent material shall not be used in contact with aluminum.

Threaded parts of aluminum shall be coated, before assembly, with anti-seize mixture of 50 per cent Zinc Dust and 50 per cent Petrolatum (by volume) or Coast Guard approved equivalent commercial product.

Label plates to be installed on aluminum structures or fittings shall be made of anodized aluminum or stainless steel and attached with adhesive, MIL SPEC MIL-A-22895.

#### (B) EXTERIOR WOOD

Wood which is to be painted, including hull planking, shall be treated as follows:

(a) Prepare surface.

(b) Apply two coats of Copper Naphthenate Wood Preservative. Allow 72 hours drying time, longer if possible, after each coat.

(c) Apply one coat of Exterior Gloss Enamel thinned by the addition of one pint of Boiled Linseed Oil to each gallon of paint.

(d) Apply two coats of Exterior Gloss Enamel as received.

Wood which is to be varnished such as accommodation ladders shall not be treated with preservative but shall be stained to the shade desired and given five coats of Spar Varnish. Undercoats shall be sanded to provide a suitable gripping surface for subsequent coats of varnish.

Wood surfaces where visual appearance is not important and where moist conditions tend to prevail shall be treated with Copper Naphthenate Wood Preservative, but not painted. The wood shall be re-treated periodically to maintain the green color in wood caused by the preservative.

Exterior wood surfaces exposed to view but not to be painted or varnished such as wood gratings shall be treated with three coats of Boiled Linseed Oil.

#### (F) EXTERIOR PLASTIC

Pigmented plastic may be freshened by rubbing down with a fine abrasive such as scouring powder or fine sandpaper to insure film adhesion and bonding. Unpigmented plastic shall be painted with one liberal coat of Pretreatment-Wash Primer and two coats of Vinyl Alkyd Paint. For further information refer to the "Maintenance and Repair Manual for Coast Guard Plastic Boats," T.P. 1625.

## 2-3-5

As an optional system for the exterior of plastic boats above the waterline when hull repair requires or condition of gel coat necessitates, clean and scrub hull and let dry. Apply Devran Exterior System Coating for Normal Service (or equivalent plastic paint system) in accordance with the manufacturer's instructions, using two coats as follows:

Formula 202, 2.0 mils dry film thickness.

Formula 209 or 219, 2.0 mils dry film in applicable color.

### 2-3-5, INTERIOR OF VESSELS—GENERAL

#### (A) UNINSULATED INTERIOR METAL SURFACES NOT SUBJECT TO MOISTURE

Interior metal surfaces (all types of metal) not subject to sweating, steam or moisture shall be painted with one of the following systems as applicable:

##### (1) CONVENTIONAL SYSTEM

- (a) Prepare the surface.
- (b) Apply 2 liberal coats of Pretreatment-Wash Primer.
- (c) Apply 1 coat of Interior Gloss Enamel.

##### (2) EPOXY SYSTEMS

- (a) Prepare the surface.
- (b) Apply 1 coat of Devran 202 or 208 Primer.
- (c) Apply 2 coats of Epoxy Enamel,  
or
- (a) Prepare the surface.
- (b) Apply 1 coat of Devran 202 or 208 Primer.
- (c) Apply 2 coats of (Chlorinated Alkyd Base) Navy Formula 124/58, MIL-E-17970.

#### (B) UNINSULATED INTERIOR METAL SURFACES SUBJECT TO MOISTURE

Interior metal surfaces subject to sweating, steam condensation, water leakage, or other forms of moisture shall be painted with one of the systems specified below as applicable. These systems shall be used for the interior of the skin of the ship, tank boundaries, pantries, galleys, heads and shower spaces:

##### (1) CONVENTIONAL SYSTEM

- (a) Prepare the surface.
- (b) Apply 1 coat of Pretreatment-Wash Primer.
- (c) Apply 1 coat of Quick-Drying Red Lead Primer.
- (d) Apply 2 coats of Interior Gloss Enamel.

##### (2) EPOXY SYSTEM

- (a) Prepare the surface.
- (b) Apply 1 coat of Devran 202 or 208 Primer.
- (c) Apply 2 coats of Devran 203.
- (d) Apply 1 color coat of Devran 209.

#### (C) INTERIOR WOOD

Interior wood surfaces which are to be painted shall be treated as follows:

- (a) Prepare the surface.
- (b) Apply 2 coats Copper Naphthenate Wood Preservative to all surfaces not coated during construction and subject to moist or humid conditions. Allow 72 hours drying time, longer if possible, after each coat.

(c) Apply 1 coat Interior White Enamel Undercoat.

(d) Apply 1 coat Interior Gloss Enamel. Wood which is to be varnished shall not be treated with preservative but shall be stained to the shade desired and given 3 coats of Spar Varnish. Undercoats shall be sanded and finish coat polished with pumice and water to give an acceptable finish.

Wood surfaces where visual appearance is not important and where moist conditions tend to prevail shall be thoroughly soaked with wood preservative and left unpainted. This includes such spaces as chain locker, tank compartments, voids, forepeaks, buoyancy spaces, lazarettes, bilges, lockers, etc. Those spaces near the transom and bow and in the area of the turn of the bilge shall be given particular attention. These spaces should be examined frequently and the wood retreated periodically in order to maintain the green color which indicates that adequate toxic material is present. It will be necessary to examine bilges more frequently than other spaces since the preservative will leach out rapidly due to the washing action of the bilge water.

Wood surfaces exposed to view but not to be either painted or varnished such as wood gratings, shall be treated with 2 coats of Boiled Linseed Oil.

#### (D) INTERIOR PLASTIC

Interior plastic surfaces should be cleaned, scrubbed and allowed to dry. Apply the same coating system as specified for Exterior Plastic, 2-3-4(F).

#### (E) INSULATION (THERMAL)

Fibrous glass board or glass cloth insulating surfaces shall be given 2 coats of Interior Gloss Enamel.

Insulmastic shall be given 1 sealing coat of aluminum Devran 209 and 1 color coat of Devran 209.

Closed cell polyvinyl chloride shall be given 2 coats of Devflex, MD2707.

### 2-3-6, DECKS AND FLOOR PLATES

Metal decks to be painted shall be treated in accordance with the foregoing general instructions for the particular location and the particular metal under consideration, except that the finish coat shall be Deck and Floor Enamel. Non-skid properties may be added to the deck paint by sweeping washed beach sand on the surface while it is tacky. Sweep the sand well into the paint, allow to dry and sweep off loose sand particles. A final coat of Deck and Floor Enamel, thinned by the addition of 1 pt. of Paint Thinner per gal. of paint, shall then be applied over the sand.

Decks to be covered by Mastic, tile or non-slip treads shall be cleaned to bare metal immediately before application of the deck covering.

The top surface of floor plates shall be wire-brushed to a bright surface and coated with a thin film of diesel oil renewed weekly. Edges and bottoms of floor plates shall be cleaned to bare metal, given a liberal coat of Pretreatment-Wash Primer and 2 coats of Quick-Drying Red Lead Primer.

Aluminum floor plates, if subjected to moisture, shall be painted on the bottom and edges with 1 coat of Pretreatment-Wash Primer and 2 coats of Yellow Zinc Chromate, Alkyd Type.

\*<sup>1</sup> OR EPOXY ENAMEL WHERE AUTHORIZED

\*<sup>2</sup> OR 60 MESH GARNET

Wooden decks shall be calked with oakum and cotton. The seams shall be filled almost to overflowing with Copper Naphthenate Wood Preservative. Care must be taken immediately to wipe up any preservative which is spilled on the wearing surface of the planking since it will stain. After the preservative has soaked in and allowed to dry, the seams shall be payed with Marine Glue or an approved seam compound.

In general, wooden decks are to be left unpainted with the exception of small work craft such as buoy boats, motor cargo boats and barges. Decks which are to be painted shall be treated as follows:

(a) Prepare the surface.

(b) Apply 1 coat of Deck and Floor Enamel thinned by the addition of 1 qt. of thinning mixture to each gal. of paint. Thinning mixture is composed of  $\frac{2}{3}$  Boiled Linseed Oil and  $\frac{1}{3}$  Paint Thinner.

(c) Apply 2 coats of Deck and Floor Enamel as received.

### 2-3-7, WATER TANKS

#### (A) ZINC DUST PAINT SYSTEM

Feed water tanks and potable water tanks shall be painted with 2 coats of Zinc Dust Paint over bare metal. Pretreatment-Wash Primer shall not be used under the Zinc Dust Paint.

To apply the Zinc Dust Paint remove all former paint coatings by sandblasting if possible; power wirebrushing may be used where sandblasting is impractical. Following the cleaning and prior to painting, the Engineering Officer shall inspect the tank to insure that all dirt, sand and rags have been removed from the tank bottom, longitudinal frames and stringers, sounding tubes, vents, filling connections and suction. Apply first coat of Zinc Dust Paint. Following the first coat of Zinc Dust Paint, unheated air shall be circulated through the tank for 12 hours. The second coat shall then be applied and unheated air circulated through the tank for 12 hours. Tanks shall then be disinfected in accordance with current directions on ship-board water purity.

CAUTION: Only enough Zinc Dust Paint shall be mixed for daily use. Mixed Zinc Dust

\*<sup>1</sup> OR APPLY OTHER APPROVED EPOXY COATING SYSTEM CONFORMING TO MIL-C-23236, CLASS 1. ROUGHEN THE SURFACE BEFORE APPLICATION.

## 2-3-8

Paint shall not be stored. After the material is mixed a gas pressure may build up within closed containers.

### (B) EPOXY COATING SYSTEM

Feed water tanks and potable water tanks may, at the discretion of the District Commander, be painted with an epoxy coating system as follows:

(a) Prepare the surface by commercial sandblasting.

(b) Apply the 3 coat Devran 207 system.

## 2-3-8, FUEL OIL TANKS

Uncoated fuel oil tanks whether fitted for ballasting or not shall be left uncoated except for the oil film.

New vessels having oil fuel tanks coated with the Devran 203 system at time of construction shall maintain this coating system as originally installed.\*<sup>1</sup>

## 2-3-9, VOIDS AND COFFERDAMS

(A) Clean to bare metal and treat with a liberal coat of Pretreatment-Wash Primer. Prime with 2 coats Quick Drying Red Lead Primer. Finish with 2 coats of Interior Gloss Enamel, White.

(B) At the discretion of the District Commander, these spaces may be coated with either the Devran 209 epoxy system (consisting of 1 coat of Devran 202 or 208 primer followed by 2 color coats of Devran 209); or with 2 coats of Coal Tar Epoxy (Tarsel or equivalent) and 1 color coat of Devran 209 after Coal Tar-Epoxy Coating is fully cured.

## 2-3-10, CHAIN LOCKER

Clean to bare metal. Apply wash primer (Formula 117). Follow with two coats of asphalt varnish, Federal Specification TT-V-51.

## 2-3-11, BILGES

(A) Clean to bare metal. Apply a liberal coat of Pretreatment-Wash Primer. Apply 2 coats of Quick Drying Red Lead Primer. Apply 2 coats of Tile Red Deck Enamel.

(B) At the discretion of the District Commander, these areas may be coated with the Devran 203 epoxy system or the Coal Tar Epoxy system provided a commercial blast can be obtained.

## 2-3-12, INACCESSIBLE SPACES

Inaccessible steel surfaces such as bilge wells, peak spaces, machinery and crane foundations, areas under built-in furniture and bulkheads behind switchboards shall be cleaned to bare metal and coated with one of the following systems for greater permanence as follows:

(a) Apply 1 liberal coat of Pretreatment-Wash Primer. Follow with 3 coats of Quick Drying Red Lead Primer.

(b) As an alternate where commercial blast can be accomplished, 2 coats of Coal Tar Epoxy may be applied to these surfaces.

Inaccessible steel surfaces such as the interiors of rudders, bilge keels, docking keels, and skegs shall be liberally coated with Thin-Film Rust Preventive, Grade 2, MIL-C-16173. The rust preventive may be applied by brush, spray or filling and draining, whichever process gives most thorough application in the particular case under consideration.

## 2-3-13, SPACE SUBJECT TO HEAVY CONDENSATION

Spaces subject to heavy condensation shall be given an antisweat treatment as follows:

(a) Clean to bare metal by commercial sandblasting if practical.

(b) Apply 1 coat of Pretreatment-Wash Primer.

(c) Apply 1 coat of Zinc Chromate Alkyd Primer, (Formula 84, Fed. Spec. TT-P-645).

(d) Apply 1 coat of Insulmastic to achieve not less than  $\frac{1}{4}$  in. thickness.

(e) Apply 1 coat of Devran 209, Aluminum.

(f) Apply 1 coat of Devran 209, color coat.

## 2-3-14, PIPING

### (A) INTERIOR PIPING

Interior uninsulated piping, the operating temperature of which is 300° F. or less, shall be thoroughly cleaned and coated as follows:

(a) 1 liberal coat of Pretreatment-Wash Primer.



(b) 2 coats Alkyd Red Lead Primer.

(c) 2 coats of Interior Gloss Enamel.

Piping below the level of the lower level floor plates shall be given an additional coat of Alkyd Red Lead Primer (3 coats total) in lieu of the Interior Gloss Enamel.

Insulated metallic piping, the operating temperature of which exceeds 300° F. shall be given 1 liberal coat of Pretreatment-Wash Primer and 1 coat of Quick Drying Red Lead Primer on the exterior surface of the pipes. The fiberglass fabric covered insulation shall be given 2 coats of Interior Gloss Enamel.

Closed cell polyvinyl chloride insulation shall be given 2 coats of Devflex, MD2707. Uninsulated metallic piping, the operating temperature of which exceeds 300° F. shall be given 2 coats of Heat-Resisting Paint, Aluminum.

#### (B) EXTERIOR PIPING

Exterior piping shall be painted in accordance with the preceding instructions for painting exterior surfaces.

### 2-3-15, MACHINERY, SHIPBOARD

#### (A) INTERIOR MACHINERY

Uninsulated metallic surfaces, other than aluminum surfaces, the operating temperature of which is 300° F. or less, shall be thoroughly cleaned and coated as follows:

(a) 1 liberal coat of Pretreatment-Wash Primer.

(b) 2 coats Quick Drying Red Lead Primer.

(c) 2 coats Light Gray Equipment Enamel.

Uninsulated aluminum surfaces, the operating temperature of which is 300° F. or less, shall be thoroughly cleaned and coated as follows:

(a) 1 liberal coat of Pretreatment-Wash Primer.

(b) 2 coats Yellow Zinc Chromate, Alkyd Type.

(c) 2 coats Light Gray Equipment Enamel.

Uninsulated metallic surfaces, the operating temperature of which exceeds 300° F. shall be thoroughly cleaned and coated with 2 coats of Heat-Resisting Paint, Aluminum.

Fabric covered insulated surfaces or rough surfaces finished with Smoothing Cement shall be given 2 coats Equipment Enamel.

Equipment presently installed having a lacquer or baked enamel finish in a color other than the prescribed color shall not be repainted for color purposes alone. When repainting is accomplished the above system shall be followed.

#### (B) EXTERIOR MACHINERY

Exterior Machinery shall be painted in accordance with the preceding instructions for painting interior surfaces.

### 2-3-16, FURNITURE AND EQUIPMENT

#### (A) INTERIOR

Furniture, joiner doors, switch boxes, controllers, switchboards, gauge boards, connection boxes, laundry machinery, galley equipment and miscellaneous equipment of all types shall be painted as follows:

(a) Prepare surface.

(b) Apply 1 liberal coat of Pretreatment-Wash Primer.

(c) Apply 1 coat Quick Drying Red Lead Primer.

(d) Apply 2 coats of Equipment Enamel.

Equipment presently installed having a lacquer or baked enamel finish in a color other than the prescribed color shall not be repainted for color purposes alone. When repainting is accomplished the above system shall be followed.

#### (B) EXTERIOR

Exterior equipment shall be painted in accordance with the preceding instructions for painting interior surfaces.

### 2-3-17, ELECTRIC CABLE

When installing new cables, interior or exterior, the support brackets shall be painted before installing cables. Cables shall be painted after they have been pulled but prior to being secured in position.

#### (A) INTERIOR CABLES

Armored cables shall be painted as follows:

(a) Apply 1 liberal coat of Pretreatment-Wash Primer.

(b) Apply 2 coats of Yellow Zinc Chromate, Alkyd Type.

(c) Apply 2 coats of Interior Gloss Enamel.

## 2-3-18

### (B) EXTERIOR CABLES

Exterior armored cable, except aluminum, shall be dip painted first in Pretreatment-Wash Primer, then in Quick Drying Red Lead Primer prior to pulling. After pulling, and prior to being secured in position, the primer shall be touched up as necessary. Two top coats of Exterior Gloss Enamel shall then be applied.

### 2-3-18, RADIO AND RADAR ANTENNAS

Radio direction finder loops, and housings and pedestals for other electronics equipment shall be painted as follows:

(a) Apply 1 liberal coat of Pretreatment-Wash Primer.

(b) Apply 3 coats of Yellow Zinc Chromate, Alkyd Type.

(c) Apply 2 coats of Exterior Gloss Enamel.

(d) Receiving antenna hardware and accessories should be painted bright blue. Transmitting antenna hardware and accessories should be painted fire red. (Except insulators, shields, ground straps and wires which should be left uncoated).

Care shall be taken to avoid painting the gasket on the direction finder antenna as well as all electrical contact points, ceramic insulators, rubber shock mounts, and other insulating material on electronic equipment, by properly masking all such parts before painting.

Instructions for painting radar antennas, radomes and similar electronic radiators are outlined in the Technical Manual.

Whip and wire antennas shall be left unpainted.

### 2-3-19, ANCHOR CHAIN

The painting of anchor chain serves no useful purpose in so far as prolonging the life of the chain is concerned. Regardless of the paint system employed it is impossible to keep paint on the points of wear. Thus, those areas which will fail first due to wear and corrosion cannot be protected by painting. Painting of anchor chain serves primarily to improve the appearance of the chain. For this reason the following low-cost paint systems shall be used on vessel anchor chain:

(a) Prepare the surface.

(b) Apply 1 liberal coat of Pretreatment-Wash Primer.

(c) Apply 1 coat of Asphalt Varnish.

Color markings shall be applied over the above coat. On light vessels that portion of the anchor chain which normally is below water when the vessel is on station shall not be painted.

### 2-3-20, PROPELLERS

Propellers, other than cast iron or cast steel, shall not be painted but shall be cleaned and polished bright.

Cast steel and cast iron propellers shall be thoroughly cleaned, and painted with the same coating system prescribed for steel hulls in either salt or fresh water as the case might be.

### 2-3-21, PROPELLER SHAFTING

#### (A) OUTBOARD

Refer to Commandant Instruction 9430.1 for coatings on exposed propeller shafting.

#### (B) INBOARD

Inboard shafting shall be thoroughly cleaned and painted as follows:

(a) Apply 1 liberal coat of Pretreatment-Wash Primer.

(b) Apply 2 coats of Quick Drying Red Lead Primer.

(c) Apply 2 coats of Light Gray Equipment Enamel.

### 2-3-22, WOOD MASTS AND SPARS

Wood masts and spars shall be treated as follows:

(a) Large checks shall be soaked with Copper Naphthenate Wood Preservative, calked with oakum (only enough material being used to provide a backer) and sealed with Oil-Type Calking Compound.

(b) Small checks and holes shall be soaked with Copper Naphthenate Wood Preservative for a period of 16 hours.

(c) Surfaces in way of fittings and partners shall be treated liberally with Copper Naphthenate Wood Preservative.

(d) Mast heel shall be soaked in Copper Naphthenate Wood Preservative for a period of 16 hours.

(e) Allow preservative to dry for 72 hours and apply 1 coat of Exterior Gloss Enamel thinned by the addition of 1 pt. of Boiled Linseed Oil per gal. of paint.

(f) Apply 2 coats of Exterior Gloss Enamel as received.

### **2-3-23, WOOD LADDERS, GANGPLANKS, STAGING AND BOATSWAIN'S CHAIRS**

Wood accommodation ladders shall be given 5 coats of Spar Varnish.

Wood pilot ladders, staging and boatswain's chairs, shall be given 3 coats of Boiled Linseed Oil. At least 24 hours drying time shall be allowed between coats.

Wood gangplanks and brows may be given either 3 coats of Boiled Linseed Oil or 5 coats of Spar Varnish.

None of the above items shall be painted in order that cracks and splits may be more easily detected.

### **2-3-24, SMOKE STACKS**

(A) The inside of the stack casings with un-insulated exhaust piping shall be cleaned to bare metal and given 2 coats of Heat-Resisting Paint, Aluminum. The inside of stack casings with insulated exhaust piping shall be cleaned to bare metal and given 2 coats of Pretreatment-Wash Primer and 1 coat of Interior White Gloss Enamel.

(B) The exterior surfaces at the top of the stack within the stack casing shall be cleaned to bare metal and given 1 coat of Pretreatment-Wash Primer, 2 coats of Red Lead Alkyd Primer followed by 2 coats of Exterior Gloss Enamel, Black.

### **2-3-25, ZINC ANODES**

The zinc anodes shall be installed over the steel surface previously coated with the complete anticorrosive system as specified for the hull.

Due to improved coatings and design of zinc anodes, it is now considered unnecessary to embed anodes in zinc oxide paste or over Coal Tar Epoxy as required previously. This will reduce labor and material without significant adverse effect on the hull surfaces.

Vessels operating exclusively in fresh water do not require zincs unless in areas of high industrial pollution.

Zinc anodes shall not be used on wooden boats except where steel is used in shafts, rudders or other important exterior appendages and only when the steel is in vicinity of, or coupled to, bronze propellers or fittings. The use of zincs reduces the effectiveness of antifouling paints and causes accelerated fouling of bronze and copper materials.

Zinc employed for protection against galvanic corrosion shall be at least 99.99% pure zinc with not over 0.0015% iron content by weight, conforming to MIL. SPEC. MIL-A-18001G.

### **2-3-26, SONAR DOMES AND TRANSDUCERS**

Section 9180.148 of the Bureau of Ships Technical Manual contains the basic instructions for the care and painting of sonar domes and transducers. The Officer responsible for the maintenance of sonar domes and transducers shall be familiar with both that portion of BuShips Manual, Section 9190.148 which relates to care of the equipment other than painting and with the instructions contained herein relative to the painting of the equipment.

#### **(A) INSPECTION AND FREQUENCY OF PAINTING**

All surfaces in contact with sea water should be inspected each time the vessel is dry-docked and treated as necessary. At each regularly scheduled availability all surfaces should be cleaned, damaged areas touched up and antifouling paint renewed. The number of antifouling coats to be applied will be dependent on the condition of the surfaces. The desired result is to reproduce the original paint film.

#### **(B) CLEANING AND PREPARING SOUND-TRANSPARENT SURFACES**

Instruction manuals should be consulted to determine the location of the various types of surfaces to be encountered in order that particular care may be taken in removing fouling from the critical areas, i.e., rubber and corrosion-resistant steel.

## 2-3-26

Remove the fouling with wooden scrapers and non-metallic non-abrasive brushes as soon after drydocking as practicable to take advantage of the soft, wet conditions of the fouling. Play a water hose on the wet sea growth to help keep it soft during the process of removal. Once the calcium encrustation arises and hardens it defies removal, which greatly increases the chances of injury to transducer diaphragm and sonar dome window.

Removal of fouling can be greatly facilitated by swabbing the affected parts with a solution of 1 volume of commercial nitric acid to 5 volumes of fresh water. Apply the solution with long-handled swabs. Allow the solution to soak a few minutes. Wipe with a rag or non-abrasive brush. Repeat the application if the surface retains some carbonate film. When satisfactorily cleaned, wash the swabbed areas with hot soapy water (on rubber surfaces use only hot water) and flush with fresh water. If the surface shows any traces of oil or grease residue after the soapy water washing, Paint Thinner may be used to dissolve and remove such persistent traces.

Inspect corrosion-resistant, sound-transparent window for pits and holes. Particular attention should be given to welded seams and spot welds. Solder such holes with a 50% lead and 50% tin solder. Commercial strength phosphoric acid may be used as a flux. Remove all excess solder and wash off all excess flux.

### (C) PAINTING OF CORROSION-RESISTANT, SOUND-TRANSPARENT WINDOWS

Exterior Surface —

(a) Apply 1 liberal coat of Pretreatment-Wash Primer.

(b) Apply sufficient coats of Vinyl Red Lead Primer (usually 5), alternating Orange and Brown coats, to obtain a film thickness of at least 6.0 mils, thus giving a total film thickness of at least 6.5 mils.

(c) Apply sufficient coats of Vinyl Anti-fouling Paint to obtain a film thickness of 3.5 mils, thus giving a total film thickness of at least 10.0 mils.

NOTE: Use scrapers and/or Paint Thinner and Paint Remover to clean surface prior to painting. Do not sandblast or chip.

Interior Surface —

Follow procedure set forth above for painting the exterior surface of corrosion-resistant, sound-transparent window except apply only 1 coat of antifouling paint.

### (D) PAINTING OF RUBBER SURFACES OF SONAR DOMES AND THE DIAPHRAGMS OF SOUND TRANSDUCERS

Clean the outside of the rubber dome with grease cleaning compound, MIL-C-20207 (GF-6850-249-8024), diluted with two to ten parts of fresh water. Wear clean oil resistant rubber gloves to avoid finger prints. Rinse thoroughly with fresh water and dry with an air blast. Apply two coats of Formula 133, MIL-P-22298, and two coats of Formula 134, MIL-P-22299. The latter is a rubber anti-fouling paint.

### (E) PAINTING OF NON-SOUND-TRANSPARENT SURFACES OF SONAR DOMES AND TRANSDUCERS

Non-sound-transparent surfaces shall be painted in the same manner as the bottom of steel hulls. Sound-transparent surfaces should be masked when shipbottom paint is applied.

## 2-3-27, BRIGHTWORK

Brightwork shall be polished and coated with lacquer. Polish the brightwork to a shiny surface with metal polish. Wipe off all polish. Remove grease film by wiping with Lacquer Thinner. Apply 1 coat of Clear Brushing Lacquer. This coating should protect exterior brightwork for several months. When the surface shows signs of tarnish, remove the old coating by wiping with Lacquer Thinner or Vinyl Paint Thinner then repeat the above procedure. Do not apply more than 1 thin coat of the Lacquer. This will facilitate its removal when necessary. Do not attempt to apply the plastic coating in humid weather as it will blush (turn a milky white).

### 2-3-28, SURFACES REQUIRING ACID RESISTANCE

Surfaces in darkroom, battery rooms and laboratories which require acid-resisting protection shall be given the vinyl paint system specified below:

#### (A) METAL SURFACES

- (a) Prepare the surface.
- (b) Apply 1 coat of Pretreatment-Wash Primer.

- (c) Apply 1 coat of Vinyl Red Lead Primer.
- (d) Apply 2 coats of Vinyl Alkyd Paint.

#### (B) WOOD SURFACES

- (a) Prepare the surface.
- (b) Apply wash primer.
- (c) Apply 2 coats of Vinyl Alkyd Paint.

### 2-3-29, SURFACES NOT TO BE PAINTED

It is impractical to enumerate all the surfaces which are not to be painted. *However, the following examples are given as a guide only.*

### SURFACES NOT TO BE PAINTED

#### *Surface*

Annunciators, Brass  
 Accomodation Ladders, Wood  
 Applicator Nozzles  
 Boat Hook Staffs  
 Boat Booms, Wood  
 Boatswain's Chairs  
 Brightwork  
 Bells, Bronze  
 Bell pulls, Brass  
 Bolts, Threaded Parts Exposed to Weather  
  
 Brows  
 Canvas Covers, Removable  
 Chain, Galvanized  
 Drain Holes  
 Deck Treads, Non-Skid  
 Decks, Stainless Steel  
 Decks, Wood  
 Decks, Resilient Tile or Linoleum  
 Dogs, for Watertight Doors, Working Surfaces  
 Fire Hose, Nozzles  
 Gaskets, Rubber, for Joints  
 Gaskets, Rubber for Watertight Doors,  
 Hatches and Airports  
 Gratings, Wood  
 Grease Cups  
 Gypsy-heads Whelps  
 Guns, Working Parts of  
 Glands, Packing  
 Gears  
 Gangplank  
 Hose, All Types  
 Heat Exchange Surfaces  
 Insulators, electrical or electronic

#### *Treatment*

Polish and coat with clear plastic or lacquer  
 5 coats Varnish (Spar)  
 Polish  
 3 coats Boiled Linseed Oil  
 5 coats Varnish  
 2 coats Boiled Linseed Oil  
 Polish and coat with clear plastic or lacquer  
 Polish and coat with clear plastic or lacquer  
 Polish and coat with clear plastic or lacquer  
 Chain, Gear and Wire-Rope Lubricating  
 Grease  
 5 coats Varnish or 3 coats Boiled Linseed Oil  
 No Coating  
 No Coating  
 No Coating  
 No Coating  
 Bright  
 No Coating  
 Wax with Liquid Floor Wax  
 No Coating; Grease working parts  
 Polish  
 No Coating  
 Pulverized graphite  
  
 3 coats Linseed Oil, Boiled  
 No Coating  
 No Coating  
 Polished and/or lubricated  
 No Coating  
 Lubricated  
 5 coats Varnish or 3 coats Boiled Linseed Oil  
 No Coating  
 No Coating  
 No Coating

## SURFACES NOT TO BE PAINTED

<i>Surface</i>	<i>Treatment</i>
Joint Faces	Uncoated or coated with suitable joint compounds
Knife-edges of WT Door and Hatches	Clean with aluminum oxide abrasive, cloth, grit #320
Ladders, Accomodation	5 coats Varnish
Ladders, Pilot	3 coats Boiled Linseed Oil
Lubrication Fittings	Uncoated
Leather Coverings	Oil with Leather Preservative, Neatsfoot Oil
Linoleum	Wax with Liquid Floor Wax
Masts, Wood	5 coats Varnish
Name Plates	No Coating
Oil Cups	No Coating
Oil Holes	No Coating
Ordnance, Working Parts of	Polished and/or lubricated
Plaques	No Coating
Railings, Wood	5 coats Varnish
Release Mechanisms	Chain, Gear and Wire-Rope Lubricating Grease
Searchlight Shutter	No Coating
Shoring, Damage Control	No Coating
Stages	2 coats Boiled Linseed Oil
Strong Backs, Wood	5 coats Varnish
Springs	No coating, or slosh with Chain, Gear and Wire-Rope Lubricating Grease
Strainers	No Coating
Threaded Parts	Chain, Gear and Wire-Rope Lubricating Grease
Valves; Stems, Glands, Threaded and Machined Parts	No coating on interior valves. Exterior valves may be coated with Chain, Gear and Wire-Rope Lubricating Grease
Zinc Anodes	No Coating



## SECTION 2-4

### COATING SYSTEMS

### FOR STEEL BUOYS

#### 2-4-1, EXTERIOR OF METAL BUOYS

Steel buoys shall normally be repainted every 3 to 5 years, depending upon whether the buoy is lighted or unlighted and upon experience gained from observations of fouling and corrosion rates in specific areas. When buoys are relieved for purposes other than repainting, consideration shall be given the need for repainting. The original and subsequent complete repainting of metal buoys, except those which have a high loss probability and those for use in the Second and Ninth Districts, shall be as follows:

##### (A) ABOVE WATERLINE

(a) Prepare the surface. Blast clean to bare metal. (Commercial blast.)

(b) Apply 1 liberal coat of Pretreatment-Wash Primer.

(c) Apply sufficient coats of Vinyl Red Lead Primer to give a total average dry film thickness of 6.5 mils. Alternate the coats between orange and brown colored primer.

(d) Apply 2 coats of Exterior Vinyl Alkyd Paint.

(e) Apply retro-reflective materials as required for identification marking.

(f) Stencil the day, month, and year of the paint application on a suitable horizontal surface.

##### (B) BELOW WATERLINE

Follow the system set forth in 2-4-1(A) above, except that in place of steps (d), (e), and (f), sufficient coats of Vinyl Antifouling Paint shall be applied to give an average dry film thickness of 3.5 mils. The total average

dry film thickness for the system below the waterline shall be 10 mils minimum.

##### (C) TOUCH-UP PAINTING

When the buoys are relieved and are to be returned to a base, the tender shall scrub down the entire buoy with deck scrubbers and pressure hoses to remove all the fouling, mud, and bird droppings possible before the surfaces dry. The following procedure shall then be followed at the base:

(a) Clean all surfaces by a light blasting to remove any residual fouling and dirt and to determine the adherence of the paint film to the metal. Areas from which the paint is missing or from which it is easily removed by this light blasting shall be given a normal blast cleaning. (Properly adhering vinyl paint is very difficult to remove by blast cleaning.)

(b) Apply 1 liberal coat of Pretreatment-Wash Primer to all bare metal areas.

(c) Apply sufficient coats of Vinyl Red Lead Primer to build up the total dry paint film thickness to 6.5 mils for the entire surface.

(d) Apply 2 coats of Exterior Vinyl Alkyd Paint to the above water area.

(e) Apply retro-reflective materials as required.

(f) Apply sufficient coats of Vinyl Antifouling Paint to the underwater area to give a total dry film thickness of 10 mils.

(g) Obliterate the date of the last painting (if necessary), and stencil the day, month, and year of the paint application on a suitable horizontal surface.

## 2-4-4

### 2-4-2, INTERIOR OF METAL BUOYS

The interior of buoys shall not be coated with paint, oil, or preservatives, except that done at the time of manufacture. Battery pockets are to be painted with the same system as the above the waterline portion of the exterior of the buoy.

### 2-4-3, METAL BUOYS WITH HIGH LOSS PROBABILITY

In some districts, particularly the Second, a high number of certain class buoys are lost each year. Whenever the expected loss of a given class of buoys exceeds 20% of the buoys of that class placed on station, the following low cost painting system shall apply to that class of buoys only:

- (a) Prepare the surface. Blast clean to bare metal.
- (b) Apply 1 liberal coat of Pretreatment-Wash Primer.
- (c) Apply 2 coats of Quick Drying Red Lead Primer on lighted buoys. Primer used

on lighted buoys to be painted black shall be tinted with 1 lb. of lamp black pigment paste (TT-P-381).

(d) Apply 1 coat of Quick Drying Red Lead Primer on unlighted buoys.

(e) Apply 2 coats of Exterior Gloss Enamel of appropriate color.

(f) The above system shall be followed above and below the waterline for lighted and unlighted buoys.

(g) Apply retro-reflective materials as required for identifying marking.

### 2-4-4, COLOR RENEWAL ON STATION

It is anticipated that some buoys may require renewal of identification color before the buoy needs repainting for protection. Such color renewal is to be accomplished on station by tenders without effort to remove bird guano or other discoloration. One coat of Exterior Vinyl Alkyd Paint applied by brush shall be used. This paint is brushable and will dry quickly enough to prevent discoloration or damage by water splashing on it. Apply retro-reflective materials as required.





## SECTION 2-5

### COATING SYSTEMS

### FOR VEHICLES

#### 2-5-1, NEW VEHICLES

New vehicles purchased by the Coast Guard shall be painted by the manufacturer using the manufacturer's enamel or lacquer in the color which most nearly matches the specified color for the vehicle.

#### 2-5-2, REPAINTING OF VEHICLES

When repainting is necessary it may be accomplished either by contract or Coast Guard Personnel. Since automotive painting requires some experience and special equipment for best results, it will generally be more economical to contract for such service. When painting is accomplished by contract, standard commercial materials may be used provided they meet Federal Specifications for the Materials Listed in the paint system below. See Article 1-11-8, Contract Painting. Colors shall match the Federal Color Numbers specified in Chapter 3.

When painting is accomplished by service personnel the following system shall be used.

(a) Prepare the surface in a manner similar to other metal surfaces. Particular care shall be taken not to nick or scratch the metal.

(b) Apply 1 liberal coat of Pretreatment-Wash Primer.

(c) Apply 1 coat of Quick Drying Red Lead Primer.

(d) Apply 2 coats Exterior Gloss Enamel.

In general the following procedure is used when painting vehicles. Surface preparation is the most difficult part of the job and will take approximately 2 days for 1 man. First, mask off all areas not to be painted. To do a good job of masking, the following sizes of

masking tape are necessary:  $\frac{1}{4}$  in.,  $\frac{1}{2}$  in.,  $\frac{3}{4}$  in., 1 in.,  $1\frac{1}{2}$  in. and 2 in. Large areas are masked with wrapping paper. Newspapers are not good for this purpose because they are easily torn and may have pin holes. Do not allow masking tape to lap over onto the surface to be painted because when it is removed, a strip of new paint may come with it. Any bright parts which are easily removed such as hub caps, hood ornaments and exterior rear-view mirrors should be removed from the vehicle. Be sure to remove the spare tire from the trunk of passenger vehicles before masking so that the spare wheel can be painted. Bright parts which cover areas to be painted such as wrap-around bumpers must be removed from the vehicle. All rust must be removed to bare metal. When machine sanding is done, numbers 60 to 80 sandpaper should be used on rust and rough places. For disc sanders use number 24 close regular sandpaper and smooth up with number 50 regular. For removing paint with a disc sander use numbers 24 to 36 open sandpaper to avoid clogging. For hand sanding never use sandpaper rougher than number 100 for dry sanding.

When all rust spots and rough places have been sanded down, wash the vehicle with Synthetic Enamel Thinner. Sand the entire surface with number 220 wet sandpaper followed with number 320 wet sandpaper fairing edges of old paint. Allow the paper to soak in water for several minutes before using. Hand wirebrush door edges and door frames to remove rust and dirt. Wash thoroughly with Synthetic Enamel Thinner to remove

### 2-5-3

grease from hinges and door locks. Dispose of rags used on these areas because they may contaminate the body of the vehicle. Sand smooth with number 220 wet sandpaper followed with number 320 wet sandpaper.

Major body work should be accomplished before starting surface preparation. Small irregularities such as rust pits and small dents should be primed and then smoothed out with body putty. This material should never be applied more than  $\frac{1}{8}$  in. thick. If thicker films are needed, apply in thin coats with adequate drying time between coats. When body putty is dry, sand down smooth with number 220 wet sandpaper followed with number 320 wet sandpaper.

Wipe the entire vehicle with a cloth dampened in Synthetic Enamel Thinner and allow it to dry. From this point on, the areas to be painted must not be touched with the bare hands. No matter how clean the hands may be, there is always some dirt, grease, oil or perspiration which will cause blistering of the paint, rust and poor adhesion.

Apply 1 spray coat of Pretreatment-Wash Primer to bare metal areas. When dry, apply 1 coat of Quick Drying Red Lead Primer to bare metal areas. When the primer has dried hard, sand lightly with number 320 wet sandpaper to remove burrs. Wipe with a cloth dampened in Synthetic Enamel Thinner and allow to dry.

Apply 2 coats of Exterior Gloss Enamel thinned with 1 pt. of Paint Thinner per gal. of enamel. Paint door edges and door frames first. Open the trunk and hood and paint around edges of trunk lid and hood. Spray the top of the vehicle, the hood, front fender, doors, rear fender, trunk, rear fender, doors, front fender and wheels in that order. To remove dust particles, use a tack rag (procureable on the open market) on each panel immediately before spraying.

Allow the first coat to dry overnight before applying the second coat in the same manner as the first coat. Very light sanding with number 320 wet sandpaper may be necessary if dust has settled on the first coat. Use a tack rag on each panel immediately prior to spraying the second coat.

Allow the finish to dry overnight and rub with rubbing compound for enamel (local

purchase on the open market is permitted). Rubbing compound for lacquer is too coarse for enamel and should not be used for rubbing enamel. Wash off the compound with clean cold water and polish the vehicle by buffing. Allow about 30 days for the finish to harden before waxing. Periodic washing and polishing will prolong the useful life of vehicle finishes.

### 2-5-3, UNDERCOATING

Undercoating shall be applied to all new Coast Guard vehicles. (Statutory limitations on purchase price of passenger cars shall be kept in mind regarding cost of undercoating.)

Specifications for purchase of automobiles, station wagons, light general duty trucks (less than 10,000 lbs. gross vehicle weight) and carry-all may or may not include underbody coating. This is due to changes in GSA purchase requirements which can be made periodically. In instances where the vehicle is received without undercoating, measures should be taken to have the coating applied prior to placing the vehicle in service. Specifications for buses, special purpose trucks, and all trucks over 10,000 lbs. G.V.W. will require that the underbody coating be applied by the manufacturer.

Where the underbody coating is furnished in accordance with specifications or as a standard equipment item, it shall be inspected to assure that adequate protection is provided. Vehicles to be operated in beach areas or outside the Continental United States shall have the underside of the body and chassis completely coated. The coating shall be applied to a minimum thickness of  $\frac{1}{16}$  in. on the underside of the hood, cab, body and chassis and to a minimum thickness of  $\frac{1}{8}$  in. on the underside of the fenders.

Undercoating compounds will not be purchased by Coast Guard units and will not be stocked by Coast Guard Supply Depots. The material is to be supplied and applied by local garages and paint shops having the special equipment needed for its proper application. The compounds approved for use on Coast Guard vehicles shall be restricted to those on the Qualified Approval List covered by Federal Specification TT-C-520.



## SECTION 2-6

### COATING SYSTEMS

### FOR AIRCRAFT

#### 2-6-1, GENERAL REQUIREMENTS

Due to the rapidly changing finishing systems, interested parties may obtain up-to-date information concerning aircraft painting from the applicable airplane and helicopter bulletins. For further information inquiries should be directed to Commandant (EAE).



# CHAPTER 3, COLOR PRACTICE

## TABLE OF CONTENTS

Section	Title
3-1,	INTRODUCTION: COLOR PRACTICE
3-2,	SCIENTIFIC PRACTICE IN THE USE OF COLOR
3-2-1,	USE OF COLOR FOR SHORE ESTABLISHMENTS, VESSELS AND VEHICLES
3-3,	GENERAL COLOR PRINCIPLES FOR SHORE ESTABLISHMENTS
3-3-1,	GENERAL EXTERIOR COLOR PRINCIPLES FOR SHORE ESTABLISHMENTS
3-3-2,	GENERAL INTERIOR COLOR PRINCIPLES FOR SHORE ESTABLISHMENTS
3-3-3,	ILLUMINATION
3-4,	COLORS FOR STATIONS (LIGHT)
3-4-1,	EXTERIOR COLORS FOR STATIONS (LIGHT)
3-4-2,	INTERIOR COLORS FOR STATIONS (LIGHT)
3-5,	COLORS FOR STATIONS (RESCUE)
3-5-1,	EXTERIOR COLORS FOR STATIONS (RESCUE)
3-5-2,	INTERIOR COLORS FOR STATIONS (RESCUE)
3-6,	COLORS FOR RADIO AND LORAN STATIONS
3-6-1,	EXTERIOR COLORS FOR RADIO AND LORAN STATIONS
3-6-2,	INTERIOR COLORS FOR RADIO AND LORAN STATIONS
3-7,	COLORS FOR AIR STATIONS
3-7-1,	EXTERIOR COLORS FOR AIR STATIONS
3-7-2,	INTERIOR COLORS FOR AIR STATIONS
3-8,	COLORS FOR ADMINISTRATIVE FACILITIES
3-8-1,	EXTERIOR COLORS FOR ADMINISTRATIVE FACILITIES
3-8-2,	INTERIOR COLORS FOR ADMINISTRATIVE FACILITIES
3-9,	COLORS FOR BASES AND DEPOTS
3-9-1,	EXTERIOR COLORS FOR BASES AND DEPOTS
3-9-2,	INTERIOR COLORS FOR BASES AND DEPOTS
3-10,	MISCELLANEOUS FURNISHINGS FOR SHORE ESTABLISHMENTS
3-10-1,	LINOLEUM AND COMPOSITION FLOORS
3-10-2,	CARPETING
3-10-3,	COUNTER AND DESK TOPS
3-10-4,	UPHOLSTERING MATERIALS
3-10-5,	DRAPERY MATERIALS
3-10-6,	WINDOW SHADES
3-11,	COLORS FOR SHORE EQUIPMENT
3-11-1,	CRANES AND SHIPWAYS
3-11-2,	DRYDOCKS
3-11-3,	FLOATING EQUIPMENT
3-11-4,	MOBILE LAND EQUIPMENT
3-11-5,	DOCK EQUIPMENT

Section	Title
3-12,	VEHICLE COLORS AND IDENTIFICATION
3-12-1,	EXTERIOR COLORS
3-12-2,	INTERIOR COLORS
3-13,	COLORS FOR VESSELS 65 FEET AND OVER IN LENGTH
3-13-1,	EXTERIOR COLORS FOR VESSELS 65 FEET AND OVER IN LENGTH
3-13-2,	INTERIOR COLORS FOR VESSELS 65 FEET AND OVER IN LENGTH
3-14,	COLORS FOR VESSELS LESS THAN 65 FEET IN LENGTH
3-14-1,	EXTERIOR COLORS FOR VESSELS LESS THAN 65 FEET IN LENGTH
3-14-2,	INTERIOR COLORS FOR VESSELS LESS THAN 65 FEET IN LENGTH
3-15,	AIRCRAFT COLORS
3-15-1,	GENERAL REMARKS
3-16,	SAFETY COLOR CODE
3-16-1,	COAST GUARD SAFETY RULES AND REGULATIONS
3-16-2,	USE OF RED
3-16-3,	USE OF YELLOW
3-16-4,	USE OF ORANGE
3-16-5,	USE OF BLUE
3-16-6,	USE OF GREEN
3-16-7,	AISLE MARKS
3-16-8,	CRANE CONTROLS AND HOOKS
3-17,	MACHINERY COLORS
3-17-1,	USE OF NO. 30 EQUIPMENT GRAY
3-17-2,	USE OF NO. 20 MEDIUM GRAY
3-17-3,	USE OF NO. 22 HIGH-LIGHT BUFF
3-17-4,	USE OF SAFETY MARKINGS
3-18,	COMPRESSED GAS CYLINDER IDENTIFICATION
3-18-1,	COLORS TO BE USED
3-18-2,	TITLES
3-18-3,	CYLINDER COLORS
3-18-4,	DECALCOMANIAS
3-18-5,	CYLINDER IDENTIFICATION, CO <sub>2</sub> FIRE EXTINGUISHERS
3-19,	PIPING IDENTIFICATION
3-19-1,	PIPING SYSTEM COLORS
3-19-2,	PIPING SYSTEM MARKINGS
3-20,	SIGNS
3-20-1,	HIGHWAY SIGNS
3-20-2,	SAFETY AND WARNING SIGNS (STANDARD STOCK)
3-20-3,	MISCELLANEOUS SIGNS
3-20-4,	SIGNS AND MARKERS FOR INACTIVE UNITS
3-20-5,	IDENTIFICATION SIGNS

Section	Title
3-21,	SAFETY HELMETS, COLORS AND MARKINGS
3-21-1,	PURPOSE
3-21-2,	IDENTIFICATION
3-21-3,	TYPE OF HELMET
3-21-4,	PRESCRIBED CODE
3-21-5,	M-1 HELMET LINERS
3-21-6,	HELMETS, SHIPBOARD
3-22,	LETTERS AND NUMERALS
3-22-1,	STANDARD LETTERING SYSTEM
3-22-2,	DRAFT NUMERALS
3-22-3,	AERIAL IDENTIFICATION AND AIRCRAFT LETTERING
3-22-4,	APPLICABLE DRAWINGS
3-23,	MISCELLANEOUS COLOR STANDARDS
3-23-1,	COLORS
3-23-2,	AIDS TO NAVIGATION REGULATIONS
3-23-3,	AMMUNITION; MARKING OF
3-23-4,	AIDS TO MARINE NAVIGATION OF THE UNITED STATES
3-23-5,	LIGHT LIST, COAST GUARD
3-23-6,	RADIATION HAZARDS
3-23-7,	CANISTERS
3-23-8,	ELECTRIC CABLES, SHIPBOARD; MARKING OF
3-23-9,	ELECTRICAL INSULATION
3-24,	COAST GUARD COLOR SPECIFICATIONS





## SECTION 3-1, INTRODUCTION:

### COLOR PRACTICE

Chapter 3 contains detail color specifications for the Coast Guard. It will be noted that in the case of shore establishments considerable choice of color is offered. This choice however is limited to the district level. District Commanders should select the color principles desired, where options are offered, and inform the units affected. Headquarters units are authorized to make their own selections of color principles where options are offered. Units shall record selections of options by underlining the option selected and deleting options not to be used in each copy of the Manual furnished the unit. Notation shall be made in the margin as to the date and authority for selection or deletion of an optional color. In making this selection the information contained in Section 3-3, General Color Principles for Shore Establishments, shall be consulted in addition to the sections covering types of shore units.

Two interior color schedules are given for vessels over 65 ft. in length. The extent of use of each of these schemes will be governed by separate directives or amendments to this Manual.

Section 3-16, Safety Color Code, is effective for shore units only. Sections other than the Safety Color Code are effective for both shore establishments and vessels where applicable. (Since the use of color for safety purposes aboard vessels presents a unique problem, the color markings to be used on vessels for safety purposes have been incorporated into the sections dealing with vessel colors.)

Chapter 3 contains color specifications only, Chapter 2 specifies the paint coating system to be applied to particular surfaces, and Chapter 4 gives ordering information and application instruction pertaining to the materials to be used.

Discretion must be exercised in applying these color specifications to surfaces not normally painted. As an example, decorative wood paneling and ceramic tile floors should be left in their natural color, whereas linoleum and resilient tile flooring should be procured in a color most nearly matching the prescribed color.

## SECTION 3-2, SCIENTIFIC PRACTICE IN THE USE OF COLOR

### 3-2-1, USE OF COLOR FOR SHORE ESTABLISHMENTS, VESSELS AND VEHICLES

The principles of color adopted for the Coast Guard have been based on extensive research and case history. Above all, purely emotional opinions in the use of color have been set aside for a more factual approach. This has been made possible by taking full advantage of technical studies in color, brightness and illumination and by referring to medical research on the visual and physiological effects of color. For a brief discussion of illumination, refer to Article 3-3-3.

So that the technique of functional color may be better understood, here are a few points regarding its application. Good vision is essential to the efficient conduct of almost

countless tasks. Abuse of the eyes rapidly leads to fatigue and to a reduced capacity to concentrate and work.

For example, glare will tend to fog vision and to prevent clear visibility, particularly of dark objects. Extreme contrasts in light and dark will likewise cause the pupil of the eye to open and close alternately and to make seeing difficult.

Vision is usually at its best where brightness in the field of view is relatively uniform. This applies not only to ceilings, overheads, walls and bulkheads, but to floors, decks and



The bright environment tends to draw attention outward and to be suitable for physical tasks that require general alertness. The softer surrounding minimizes the distraction of the environment, aids concentration, and is suitable for difficult visual and mental tasks.

equipment, all of which should not conflict with each other. Where possible, surrounding brightness should equal task brightness; the poorest situation is that in which the environment is exceptionally bright and the task dark. The reason for this is that the eye is quick in adjusting itself to darkness. Thus, exposed lighting fixtures, white walls and bulkheads (which usually hold little significance) will impair an ability to work comfortably at desks, machinery or equipment having a dark finish.

By controlling the colors of walls, bulkheads and work surfaces, the requirements of clear visibility may be met. Coast Guard color standards have been carefully selected to agree with modern technical practice. In general, ceilings and overheads should be white for high light reflection and diffusion and to minimize shadows. Wall and bulkhead reflectances should be between 50 and 60 per cent where fairly difficult seeing tasks are performed. Paler colors may be used in large working areas and in spaces devoted to storage or incidental traffic.

Floors, decks, and working surfaces should reflect above 25 per cent where possible and should not be dark except where low illumination levels are required (as in Timer Rooms at Loran Stations and Combat Information Centers aboard ship).

In addition to a proper control of brightness, color serves the added function of offering psychological relief from extremely high or low temperature conditions. Certain principles in this Manual recommend the use of cool tones of green and turquoise for areas in which average temperature may be above normal, particularly for south and west exposures. Similarly, tones of yellow, sand and coral are suggested for facilities having a cooler average temperature, particularly for north and east exposures.

On building exteriors, the use of white or a pale color will, under intense sunlight, reduce interior temperatures by reflecting heat rays. This will add to comfort in personnel facilities as well as reduce high temperatures in sheds used for storage.

Where safety is important, a special color code has been designed. This code is standard in all Naval shore establishments and is



Strong contrasts in the field of view will rapidly cause fatigue and lower the efficiency of the eye to see clearly. The ideal condition is one in which there is approximately uniform brightness on walls, equipment and floors.

widely employed throughout American industry. Colors of high visibility, such as yellow and orange, are used to mark points of danger; red is reserved for fire protection and damage control; green for the identification of first aid equipment; and blue for electrical controls in general.

The color standards accepted for the Coast Guard are twenty-four in number and are shown in two charts at the end of Chapter 3. Interior finishes have been checked for ideal reflectance under the conditions in which they will be used. It will be noted that many of these are soft in tone both to avoid needless emotional distraction and to resist soiling

### 3-2-1

and abuse. Machinery and equipment finishes in gray will assure a clean appearance, reflect more light than the conventional dark gray of the past, and will also be easy to maintain and "touch up." In exterior colors, pigments and synthetic resins able to resist prolonged outdoor exposure have been chosen. White, No. 11 Sun Tan, and No. 19 Light Gray for walls and siding, No. 26 Tile Red for roofs, and No. 12 Spruce Green for trim, will have excellent permanence under all climates. The safety code colors are as brilliant as modern chemical formulation will permit.

As to the visual and emotional qualities of colors themselves, the Coast Guard standards are of fairly simple and direct order and are

meant to appeal to average human taste. It will be noted that "fashionable" types of colors, such as yellow-greens, orchids, pinks and the like, have been avoided for hues having greater universal and, therefore, more fundamental and lasting beauty.

Painting is a costly maintenance expense. Where formerly paint finishes have been used for the preservation of surfaces and materials, they today have added functions that concern human efficiency and well being. Through the use of this Manual, which brings together the most advanced thinking in color science, it is expected that the facilities of the Coast Guard will be improved and that better service and appearance will result.

## SECTION 3-3, GENERAL COLOR PRINCIPLES

### FOR SHORE ESTABLISHMENTS

#### 3-3-1, GENERAL EXTERIOR COLOR PRINCIPLES FOR SHORE ESTABLISHMENTS

Nine color standards have been established for outdoor buildings and structures. The majority of these are illustrated on the opposite page and are shown in various air view drawings which precede the discussion of the different types of Coast Guard shore construction. In certain cases the structures are left unpainted. As an example, masonry structures shall be left unpainted where appearance or identification is not important. Also aluminum roofs or entire aluminum structures shall be left unpainted.

**WHITE.** As in the past, white is standard for most types of painted structures. This would apply to wood dwellings and buildings, stucco and concrete where painted. Outbuildings, galvanized steel sheds (not industrial) and Quonset huts should also be white.

White is the prescribed trim color for red brick buildings, being applicable to window sash, storm doors and windows, gutters, eaves, doors, porch and stair balustrades. It should be used for wood picket fences. Lighthouses should remain as at present and be painted in accordance with the requirements of the Light List.

Flag poles should always be painted white whether of wood or metal, unless the metal is corrosion resistant.

**No. 12 SPRUCE GREEN.** This is a Coast Guard color which has been given a wide number of uses for outdoor structures. It is a durable chromium oxide finish that has excellent color retention properties.

On white dwellings and buildings No. 12 Spruce Green should be used for exterior trim, window sash, doors, shutters, wood lattice under porches, roof vents, weather vanes, storm doors and windows. It may also

be specified for the trim on buildings used for industrial purposes at Bases and Depots.

It should be used for metal fences, metal railings, catwalks, ladders, lampposts, metal clothes poles, wind instrument staffs and outdoor waste receptacles. Ornamental iron, however, may be painted black as an alternate.

On tall stationary structures No. 12 Spruce Green should be applied to steel structures supporting water tanks. A steel tank, roof included, should be white. Radio antenna poles and towers, flag towers, range light towers, storm warning towers, lookout towers, air tanks outside of buildings should also be No. 12 Spruce Green. (Wood structures on towers should be white.) It is specified for bridges and trestles, large shipways, tall dry dock cranes, hammerhead cranes.

Steel storage tanks (more than 1,000 gals. capacity) should also be No. 12 Spruce Green. However, small gasoline and diesel oil tanks, also paint lockers, should be painted No. 14 Brilliant Yellow, with black lettering.

**Note:** Where all structures are near airfields, these must be painted No. 18 International Orange and white as required by Federal Aviation Agency. (See FAA bulletin, Obstruction Marking and Lighting. Available from Superintendent of Documents, Government Printing Office, Washington, D.C. 20402). Tall structures used as Aids to Navigation shall be painted to conform to the Light List.

**No. 11 SUN TAN.** This color is acceptable as an alternate for white in tropical regions or continued snow covered northern sites where sunlight glare is to be reduced. Trim for No. 11 Sun Tan dwellings and buildings should be No. 12 Spruce Green.

**No. 19 LIGHT GRAY.** This is the color specified for industrial types of buildings and warehouses, particularly those located at Bases and Depots where white may be impractical. It may also be used for painted

### 3-3-1

chimneys (aluminum heat-resistant paint would be an alternate where surfaces of high temperature exist). Where industrial buildings are No. 19 Light Gray, trim should be No. 12 Spruce Green as described above.

No. 19 Light Gray should be used in the form of a deck paint as a standard on all traffic areas such as porch floors, stairs, ramps, platforms and bleachers, both interior and exterior. No. 20 Medium Gray may be used on traffic areas where maintenance is difficult, such as floats, launchings, loading docks and shop floors.

No. 20 MEDIUM GRAY. In addition to being an alternate for No. 19 Light Gray on traffic areas, No. 20 Medium Gray is the prescribed color for outdoor shore equipment such as winches, small movable cranes, truck cranes, derricks, and locomotives.

No. 26 TILE RED. This color is for painted roofs to blend with the existing red roofs found at most Coast Guard units.

No. 18 INTERNATIONAL ORANGE. This color is designed for high visibility at long ranges. It gives high average conspicuity against the wide variety of sea and land backgrounds. It should be used with white for tall structures near air fields as required by Federal Aviation Agency. (See FAA bulletin, Obstruction Marking and Lighting.)

No. 13 FIRE RED and No. 33 SEAL BROWN. These two colors are specified for lighthouse structures and should be applied as directed by the Light List.

No. 29 BRIGHT BLUE. The colors of blue and white have long been associated with Coast Guard activities. When this color combination is used to represent the Coast Guard the blue color shall conform to No. 29 Bright Blue.

### 3-3-2, GENERAL INTERIOR COLOR PRINCIPLES FOR SHORE ESTABLISHMENTS

In using this Manual it should be appreciated that the specification of color for the widespread facilities of the Coast Guard involves many complications. Due to problems of supply and storage it is necessary to standard-

ize on a limited number of colors. These must serve a multitude of uses and be formulated in brightness and hue to agree with the best of modern scientific practice. Special type paints of the same color are frequently required for indoor and outdoor use, for metal surfaces, wood, plaster and concrete. Added colors, therefore, increase the stocking problem.

A great deal of research, study and case history has gone into the organization of the principles included herewith. An exhaustive check has been made on almost countless major and minor items found at shore units. It is expected that the Manual will be convenient to use and will lead to improved facilities.

For the sake of simplification, several uniform practices are recommended. For example, *all ceiling and overhead areas should be white*. There are practically no exceptions to this other than in certain control towers and special interiors where operations are unusual.

Again the common practice of having a special trim color for every wall color has been avoided. This would mean double inventories for many standards and add to costs for paint supplies and labor. Interior trim in family quarters may be the same color as adjacent walls or white. Trim in all other shore facilities should be uniformly white or No. 19 Light Gray, except in some industrial applications where dadoes are recommended. Here, however, no special paints are required other than those adopted for other standard purposes. Except for family quarters, uniform white trim is standard for doors, door frames, baseboards and window sash in living and operational facilities at Light Stations, Rescue Stations, Radio and Loran Stations. Where deeper trim finish would be more practical, such as at Air Stations, Bases, Supply Depots and other large industrial establishments, No. 19 Light Gray may be used. This principle will simplify the task of painting as well as help to tie all facilities together for a neat and orderly appearance. Radiators may be in the wall or trim color.

Wall colors should as a rule extend to picture molding or ceilings. In industrial areas having high bays, wall colors should extend

to a line level with the bottom of roof trusses. All areas above, including sash in monitors and skylights, should be white. Ceilings should never be tinted unless specific instructions are given to the contrary.

#### (A) NON-INDUSTRIAL SCHEMES

Eighteen principles have been devised for interiors from a limited number of color standards. Variety is thus assured with a restricted paint inventory.

**PRINCIPLE A, No. 1 Light Green.** This color may be widely used for ward rooms, living spaces, sleeping quarters, mess halls, recreation rooms, offices, classrooms, laboratories and sick bays. It has a reflectance of about 55 per cent and will assure a glare-free environment having a cool and fresh appearance. It is suitable for most climates and particularly well adapted to areas in which personnel are concentrated.

**PRINCIPLE B, No. 9 Pearl Gray.** This cool, neutral color is appropriate for living spaces, ward rooms, offices, classrooms and laboratories. Its best purpose is served in providing a subdued, non-distracting environment for the execution of confining visual and mental tasks. It is not proposed for climates having a low average temperature.

**PRINCIPLE C, No. 25 Beach Sand.** This color is warm in tone and will help compensate for low average temperatures. It is recommended for living spaces, sleeping quarters, mess halls, rest rooms, general offices, sick bays.

**PRINCIPLE D, No. 4 Soft Yellow.** This high reflectance color is an ideal standard for passageways and stairways and for other such areas deprived of good natural light. It is suitable for living spaces, sleeping quarters, large general offices. Because of its high brightness, however, it is not recommended for areas in which difficult visual tasks are performed. It is excellent for cold climates.

**PRINCIPLE E, No. 23 Turquoise.** This is a cool color proposed for limited application. Being fairly pure in tone it is suitable for living quarters, ward rooms, lounges and recreation areas, mess halls where a cheerful appearance is wanted. It is not suggested for

offices, classrooms or work spaces where it may prove distracting.

**PRINCIPLE F, No. 6 Ivory.** This is a general purpose color for passageways and stairways, large spaces such as gymnasiums. Its high light reflection will be appropriate to areas having poor natural light. It is not suitable for small offices, nor for living spaces where a more colorful environment would be superior.

**PRINCIPLE G, No. 2 Medium Green.** This soft color should be given restricted application. It is suitable for living rooms and mess halls in dwellings, for reception rooms, lounges and rest rooms where a quiet and restful atmosphere would be comfortable, relaxing and appropriate. It should not as a rule be applied to work spaces, except where dim lighting conditions are prescribed as in CIC areas aboard ship or in certain facilities at Radio and Loran stations.

**PRINCIPLE H, No. 7 Coral.** This is the brightest and warmest of all Coast Guard Color standards. Its use should be limited to recreation areas, parlors, lounges, living rooms in shore dwellings, recreation or messing spaces. A color as bright as this needs restraint and should be complemented by other and more subdued colors in adjacent facilities. No. 7 Coral should be avoided in working or operational areas.

**PRINCIPLE I, White.** Although white is a clean, bright finish, it may produce glare. This principle is recommended for unimportant spaces little occupied, such as storage spaces, closets and locker rooms. To assure cleanliness and high standards of housekeeping it is also prescribed for sanitary spaces such as heads, galleys, pantries, sculleries, laundries. Because of high light reflection it may also be used for passageways and for examining and treatment rooms in infirmaries.

**PRINCIPLE J, No. 9 Pearl Gray, with No. 23 Turquoise.** In using end wall effects, the No. 9 Pearl Gray should be applied to three walls, with the No. 23 Turquoise restricted to one wall—preferably faced by personnel and not having windows. Thus the principle is suitable for training rooms, reception rooms, general offices, drafting rooms, laboratories,

### 3-3-2

special shops where difficult seeing tasks are performed and where the end wall will serve a functional purpose in removing glare from direct line of sight.

PRINCIPLE K, No. 9 Pearl Gray, with No. 4 Soft Yellow. This principle is applicable to rooms deprived of good natural light and where personnel may be concentrated. For the best effect the No. 4 Soft Yellow end wall should be at the far side of the room away from windows. The scheme is suitable for training rooms, reception rooms, general offices, drafting rooms.

PRINCIPLE L, No. 9 Pearl Gray, with No. 7 Coral. Three gray walls combined with one end wall in No. 7 Coral is effective for reception rooms, recreation areas, lounges, women's rest rooms, training rooms in relatively cold climates. Its use should always be limited.

PRINCIPLE M, No. 25 Beach Sand, with No. 7 Coral. This color scheme has very limited use. It is a good combination for recreation rooms in cool climates, having a warm and luminous quality. It is also suitable for women's rest rooms and for reception rooms. It is an alternate for Principle C and may be specified where a deeper trim color is desirable in lieu of white or light gray.

#### (B) INDUSTRIAL SCHEMES

The following principles are for areas having relatively severe usage, for shops and industrial plants where a deep trim color is most practical. The trim color may in all cases be applied to doors, door frames and dados. Window sash is best in the trim color if metal, and in the wall color if wood. Radiators should be preferably in the deeper trim color.

In industrial plants having high bays, overhead steel trusses and beams may be No. 19 Light Gray. Otherwise all ceilings and overhead, wood and concrete beams, should be white.

PRINCIPLE N, White with No. 23 Turquoise. The combination of white with No. 23 Turquoise would be suitable in industrial applications where temperatures may be on the high side and where lighting conditions may be none too good. This would apply to

large shops, foundry, heat-treating, high bay industrial interiors deprived of good natural daylight or relatively weak artificial light.

PRINCIPLE O, No. 1 Light Green, with No. 2 Medium Green. This is perhaps the most useful of all principles for working areas. It is recommended for industrial facilities and workshops where personnel is concentrated, and for offices having heavy traffic or occupancy. No. 1 Light Green has an ideal reflectance for relief from glare and ease of seeing, and it is restful and cool in quality. No. 2 Medium Green for dado and trim will withstand abuse and simplify maintenance. Principle O is suitable for almost all climatic conditions.

PRINCIPLE P, No. 4 Soft Yellow, with No. 19 Light Gray. This industrial color scheme is proposed for areas deprived of good natural light or for windowless or below ground working spaces. It is suggested for large workshops, boat houses, hangars, garages. Being warm and luminous in tone, yellow is suitable for cool climates and for large spaces where artificial heating may be none too adequate during winter months.

PRINCIPLE Q, No. 9 Pearl Gray, with No. 19 Light Gray for dado and trim. This is an extremely conservative color effect and useful where a glare-free and non-distracting environment is wanted, such as in classrooms, laboratories, offices. It would look best in new rather than old facilities and in combination with other more colorful effects in adjacent areas. Principle Q, while suitable for severe visual and mental tasks, needs variety and a change of pace elsewhere in a complete shore unit.

PRINCIPLE R, White with No. 19 Light Gray. This simple combination is recommended for relatively unimportant areas where occupancy is light and where difficult seeing tasks are not performed. Included would be storage and stock rooms. In boiler rooms, engine rooms, furnace rooms, emergency power rooms, the addition of No. 26 Tile Red on floors shall be used.

#### (C) FLOOR COLORS

1. Wood floors in a natural finish shall be cleaned, sealed and protected with a floor wax



rather than painted. Where floors are painted, four standard floor colors are available: No. 19 Light Gray, No. 20 Medium Gray, No. 26 Tile Red, and No. 31 Deck Green. No. 19 Light Gray is the preferred finish for average floors, being practical and easy to maintain. It should be used for sleeping quarters, offices, training areas and laboratories. The deeper No. 20 Medium Gray should be used for industrial areas, workshops, garages, boat houses. No. 26 Tile Red is prescribed for engine rooms, boiler rooms, furnace rooms, generator rooms and the floors of emergency power plants. No. 26 Tile Red or No. 19 Light Gray may be used for passageways, mess halls, recreation areas, heads and locker rooms. No. 31 Deck Green may be used as an alternate for No. 19 Light Gray and applied to the floors of ward rooms, living quarters, sleeping rooms, first aid departments, sick bays.

2. Concrete floors shall not be painted unless required to correct unsightly appearance.

3. For composition floors see Article 3-10-1. While asphalt tile is one of the low cost materials, vinyl asbestos tile has come into widespread use and is generally recommended. The dark, drab colors of the past should be avoided for lighter tones of gray, green and tan.

4. As to carpeting see Article 3-10-2. For tufted carpeting, nylon, acrylic or olefin fibers are all practical and relatively low in cost.

Nylon is also water-resistant and fire-retardant. Simple twist or tweed textures are recommended in gray, green or tan.

#### (D) EQUIPMENT

In non-industrial facilities, fixed equipment against walls, such as cabinets, should be in the wall or trim color. Shelving, bins, racks and movable equipment such as tables, benches, desks should be No. 30 Equipment Gray for the sake of uniformity and adherence to one standard finish.

In industrial areas, fixed equipment against walls may also be in the dado or trim color. As above, No. 30 Equipment Gray should be used as a standard for miscellaneous equipment such as benches, bins, racks, shelving and wire screening. However, where equipment is subject to severe usage, it may be painted No. 20 Medium Gray as an alternate. Heated surfaces such as ovens, heat treating units, metal boiler fronts should be painted with a heat-resistant aluminum paint. Insulated boilers should be white. Vent and exhaust ducts should be white where they run against ceilings and may be kept relatively clean. In those cases where vent ducts extend down into the interior, that portion of duct below the ceiling should be painted No. 19 Light Gray.

#### (E) MACHINERY

For the application of color to industrial machinery see Section 3-17, Machinery Colors.



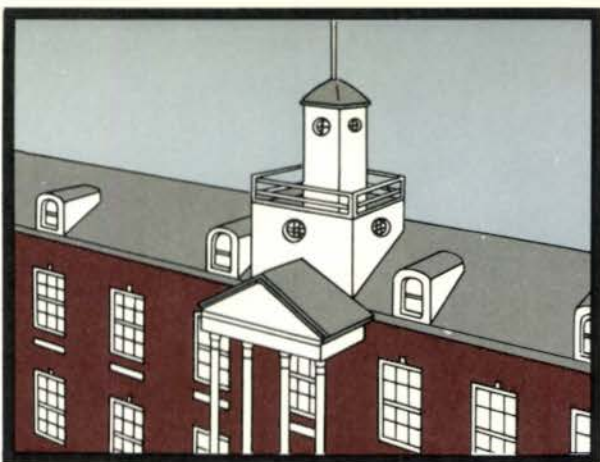

WHITE. For trim on red brick buildings.



NO. 12 SPRUCE GREEN. A trim color for white buildings, poles, fences, etc.

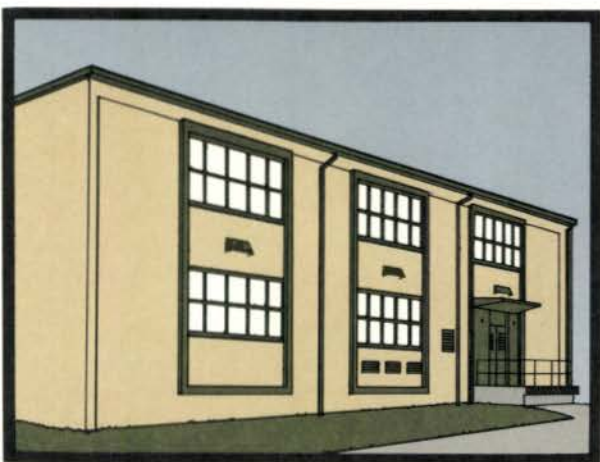

NO. 11 SUN TAN. For dwellings and buildings where glare is to be reduced. NO. 12 SPRUCE GREEN for trim.

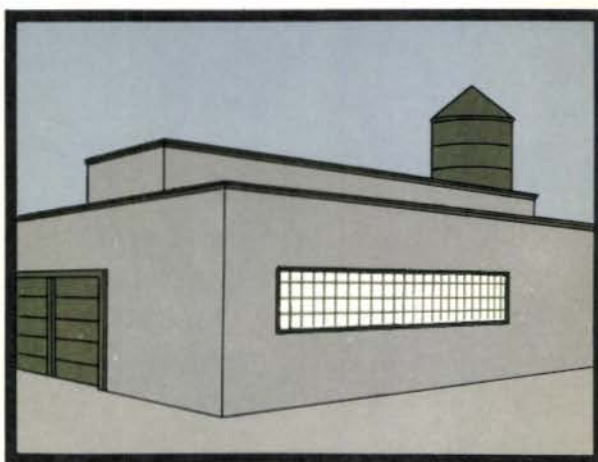

NO. 19 LIGHT GRAY. For industrial buildings. NO. 20 MEDIUM GRAY for equipment.

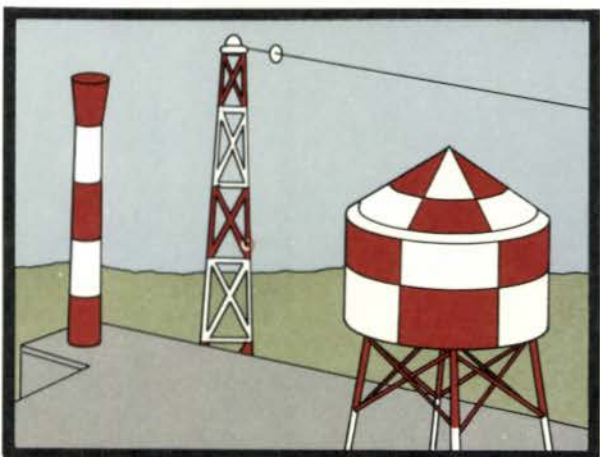

NO. 18 INTERNATIONAL ORANGE. Used with white for tall structures near air fields.



NO. 13 FIRE RED. NO. 33 SEAL BROWN. For lighthouses as prescribed by the applicable Light List.



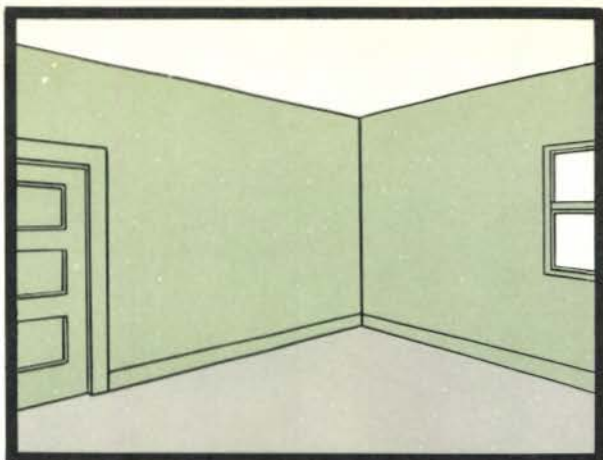

PRINCIPLE A, No. 1 Light Green. A cool color for living spaces, sleeping quarters, offices.

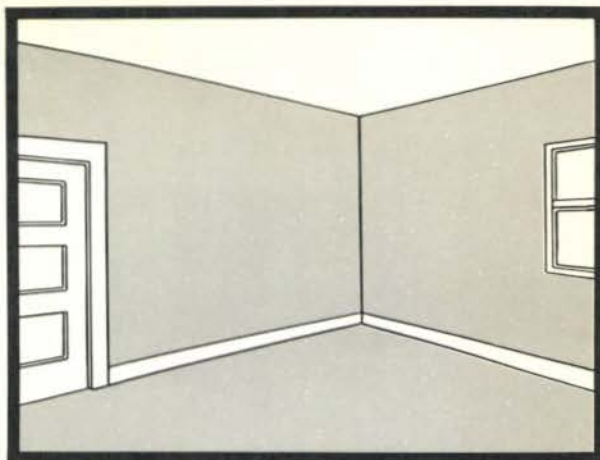

PRINCIPLE B, No. 9 Pearl Gray. For living spaces, offices, and areas where difficult visual tasks are performed.

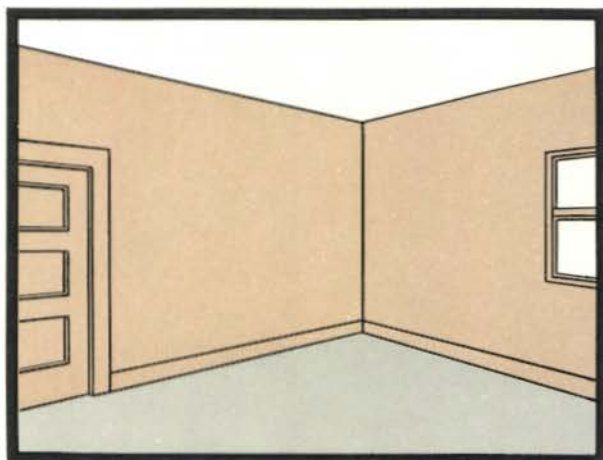

PRINCIPLE C, No. 25 Beach Sand. A warm color for living spaces, sleeping quarters, mess halls and general offices.

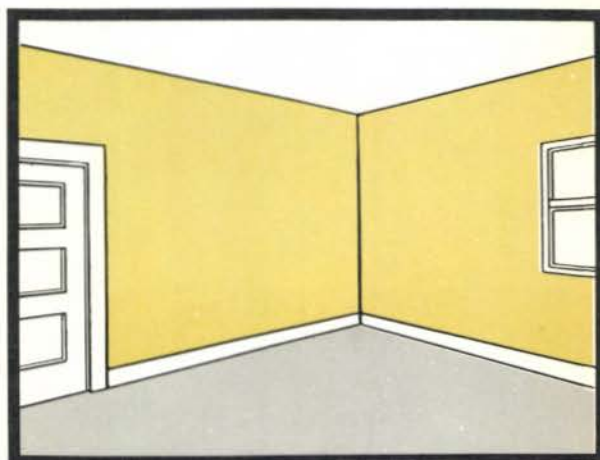

PRINCIPLE D, No. 4 Soft Yellow. A high-reflectance color for passageways and areas deprived of good light.

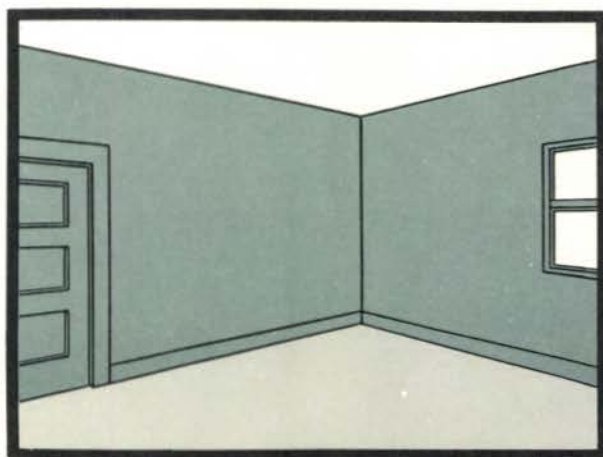

PRINCIPLE E, No. 23 Turquoise. A cool color for living spaces, recreation areas and mess halls.

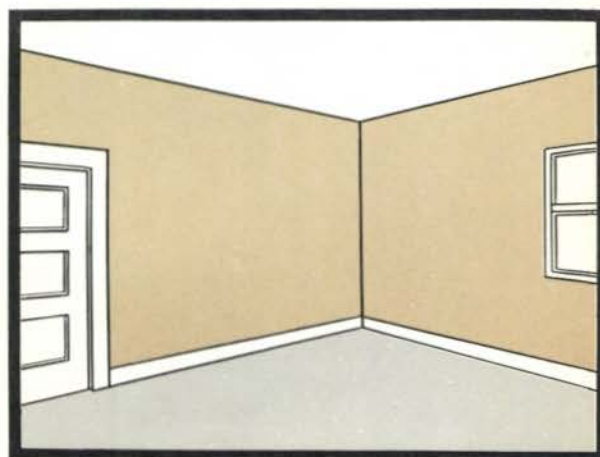

PRINCIPLE F, No. 6 Ivory. A general purpose color of high reflection. For passageways or areas needing light.



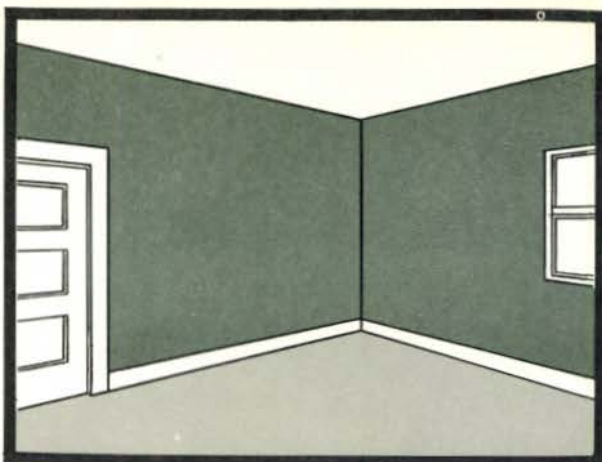

PRINCIPLE G, No. 2 Medium Green. Limited application for living rooms, reception rooms, women's rest rooms.

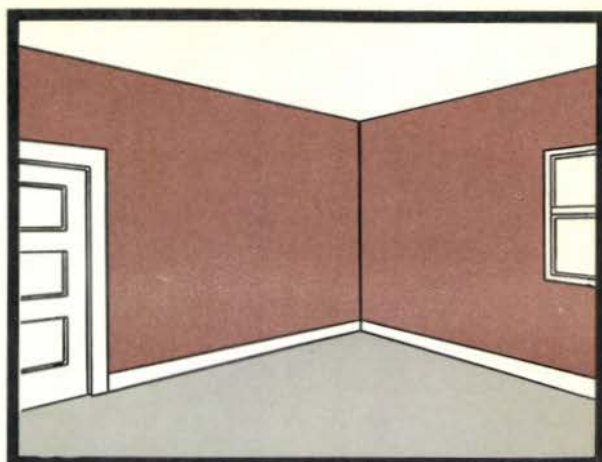

PRINCIPLE H, No. 7 Coral. Limited application for living rooms, mess halls, women's rest rooms.

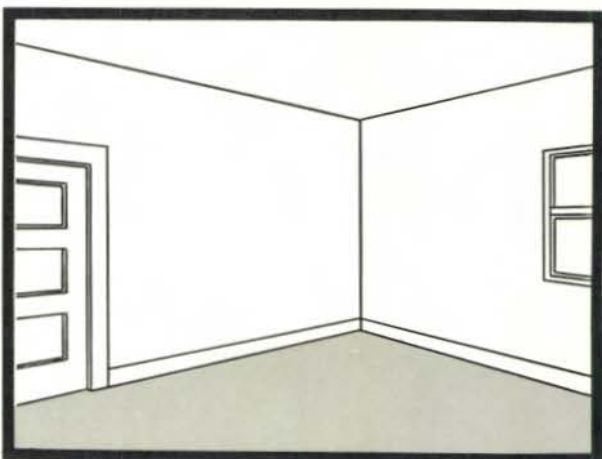

PRINCIPLE I, White. For areas devoted to storage, lockers. For galleys, heads, examining rooms in infirmaries.

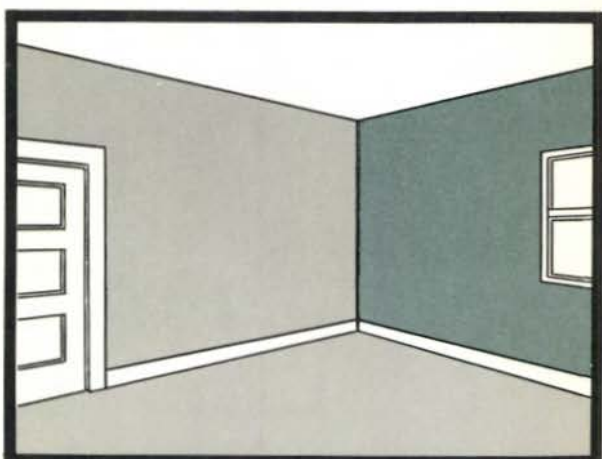

PRINCIPLE J, No. 9 Pearl Gray with No. 23 Turquoise end wall. For training rooms, offices, drafting, shops.

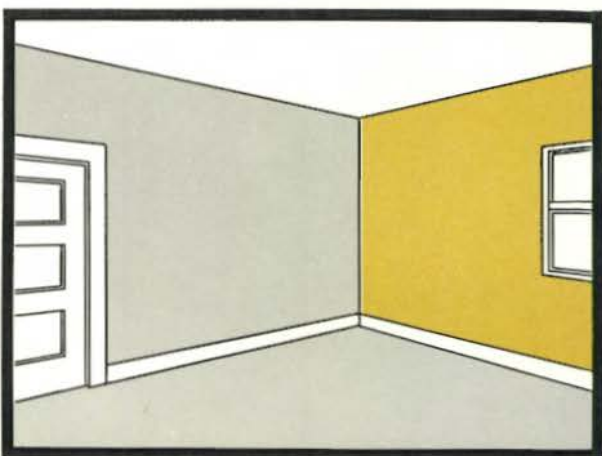

PRINCIPLE K, No. 9 Pearl Gray with No. 4 Soft Yellow end wall. For training rooms, offices, etc.

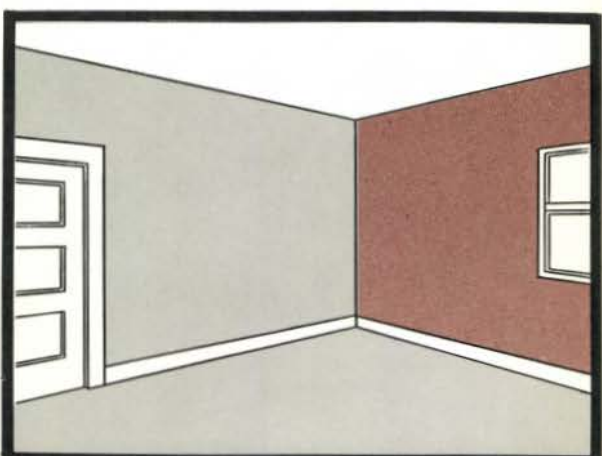

PRINCIPLE L, No. 9 Pearl Gray with No. 7 Coral end wall. For reception, recreation rooms, etc.





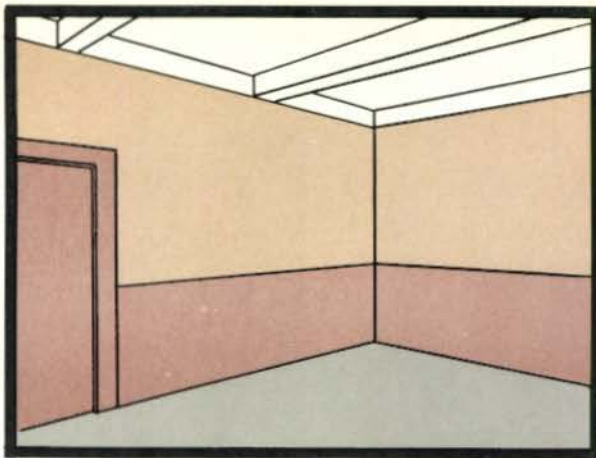

PRINCIPLE M, No. 25 Beach Sand with No. 7 Coral dado and trim. Limited application in cool climates.

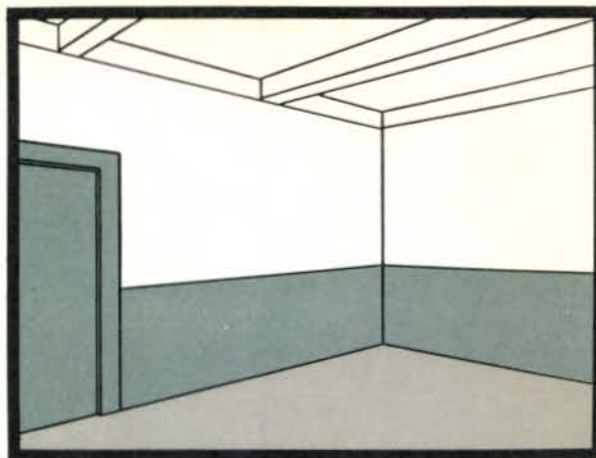

PRINCIPLE N, White with No. 23 Turquoise is suitable where temperatures may be high or natural lighting poor.

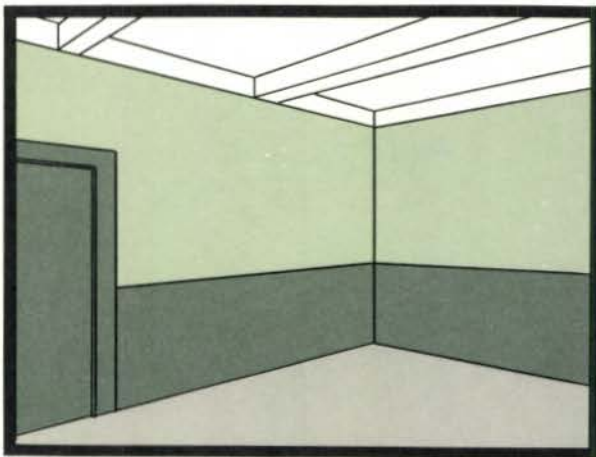

PRINCIPLE O, No. 1 Light Green with No. 2 Medium Green dado. For shops and offices having high occupancy.

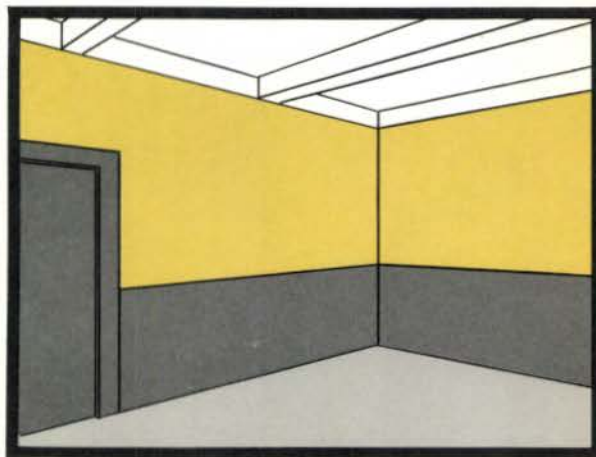

PRINCIPLE P, No. 4 Soft Yellow with No. 19 Light Gray dado. For large areas and shops having poor natural light.

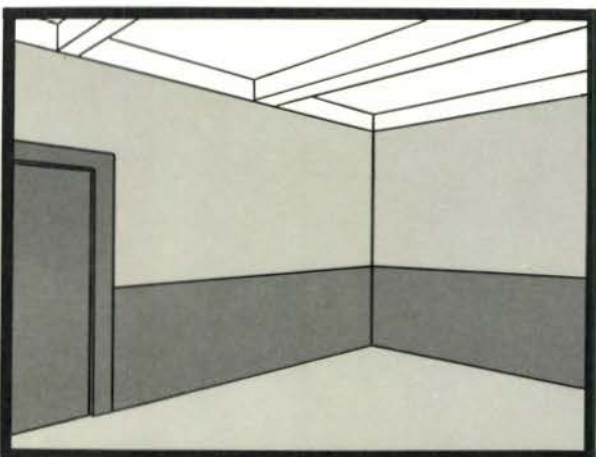

PRINCIPLE Q, No. 9 Pearl Gray with No. 19 Light Gray dado. For working areas free of glare and distraction.

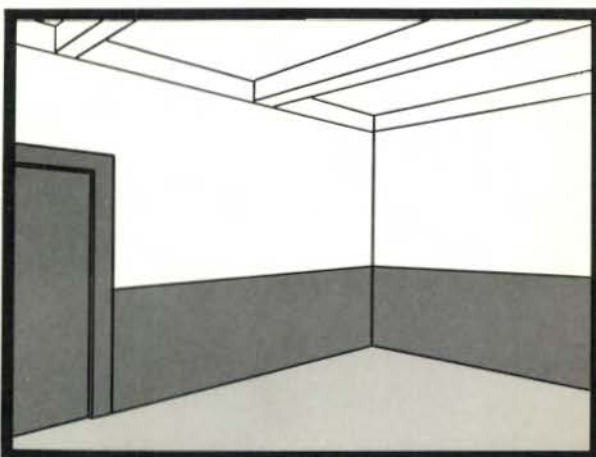

PRINCIPLE R, White with No. 19 Light Gray dado. For storage, boiler rooms, engine rooms, emergency power.



### 3-3-3, ILLUMINATION

Adequate light levels are important to comfortable and efficient vision. The purpose of light, of course, is to reveal the world and all its surfaces and objects. The best lighting condition exists where the colors and degrees of brightness in the environment are properly coordinated with the light itself, whether natural or artificial. Also see Article 3-2-1, Use of Color for Shore Establishments, Vessels and Vehicles.

Although lighting conditions throughout the Coast Guard, both in shore facilities and on vessels, differ considerably, certain well defined points may be set forth.

In the control of daylight through the use of window coverings, light colors are preferred to dark colors in window shades and Venetian blinds. There are two reasons for this. The window shade if light in color and somewhat translucent (semi-opaque) will, by transmission, diffuse natural light during the day. With the shade fully or partially drawn at night, it will also act as an efficient reflecting surface for artificial light. The same is true of the Venetian blind. Thus shades and blinds are preferred in white, ivory or pearl gray tints. Dark colors such as green and blue should be avoided. Where near-darkness is wanted during the day — such as in sleeping quarters or where projection equipment is used — fully opaque shades or blinds should be specified in white, ivory or pearl gray.

Under no conditions should an attempt be made to match Venetian blinds in wall colors (other than white, ivory or pearl gray). This would be costly, would cause unfavorable tinted light reflections, and it might create a motley appearance from the outside of the building.

Because of the recent development of efficient artificial lighting sources, higher light levels than in the past have now become the rule. In Coast Guard facilities where work tasks may be performed — offices, classrooms, electronic and other shops — at least 50 foot-candles should be provided. This would be satisfactory only. Higher levels will be desired and should be allowed for in any instance where difficult and critical eye tasks are undertaken. Let the following principles be observed.



An example of good fluorescent lighting in a classroom. Troffer units are installed in a hung ceiling for better reflection and attractive appearance.



An example of mercury lighting in an industrial shop. Note good distribution of illumination. Photographs courtesy of the Holophane Company.

Keep lighting fixtures on the high side and out of the direct range of vision. See that all tubes or lamps are well shielded.

Incandescent lamps are perfectly satisfactory for average situations not concerned with severe use of the eyes. Incandescent sources (shielded) are quite appropriate to general living quarters, mess, barracks, rest and recreation areas, lounges, etc. Allow for individual desk or floor lamps where they seem needed.

### 3-3-3

The warm orange tint of the incandescent lamp is friendly and flattering to average human complexion.

Where higher levels of illumination are wanted, and where fluorescent tubes are employed, the 3500° Standard Warm White tube is perhaps best. It is quite efficient in light output, and the color quality is fair. Where good color discrimination is required, the 4500° Cool Daylight White tube — or the De Luxe Standard North Daylight tube — may be specified.

For industrial lighting in shops having high overhead or high bays, color-corrected mercury lamps are best (if fluorescent tubes are not presently installed).

Avoid "flat lighting" for the most part. The eye not only needs ample light to see clearly, but such light should reveal the form of things, highlights and shadows. Thus highly diffuse light should be avoided for light that has a dominant (but not extreme) direction.

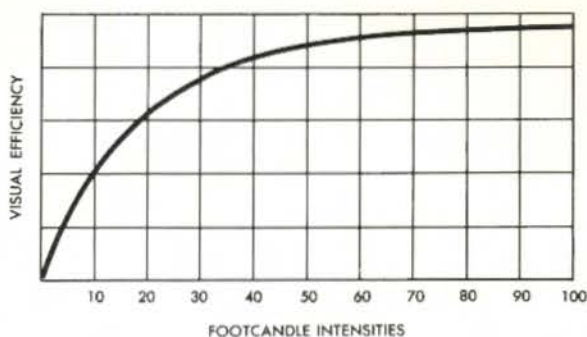

Seeing efficiency rises at a rapid rate as light level is increased. At about 50 footcandles (optimum), the line straightens out, and added seeing efficiency may require double and triple increases in intensity.

## SECTION 3-4, COLORS FOR STATIONS (LIGHT)

### 3-4-1, EXTERIOR COLORS FOR STATIONS (LIGHT)

The exterior painting of light stations, including all structures identified in Light List descriptions, shall follow the color scheme prescribed by the applicable Light List. The below color scheme applies in all instances where there is no conflict with the Light List.

#### (A) WOOD, METAL AND PAINTED MASONRY BUILDINGS

The exteriors of buildings shall be painted white, including siding, eaves, gutters and downspouts (where painted), wood porch enclosures, wood porch railings and wood stair structures and balustrades. Trim shall be No. 12 Spruce Green. This includes window sash, shutters, doors, trellis under porches, roof vents, weather vanes, storm doors and windows, metal porch railings, metal stair structures and metal balustrades. Ornamental iron may be black.

In high glare regions such as the tropics or continued snow covered northern sites, all pertinent buildings at each station may be painted No. 11 Sun Tan to reduce glare. Where this standard is used, trim as above using No. 12 Spruce Green for trim and grade beam.

#### (B) RED BRICK BUILDINGS

White shall be used as a trim color on window sash, shutters, doors, eaves, gutters and downspouts (where painted), wood columns, wood balustrades, wood ornamentation, storm doors, storm windows and trellis under porches. Metal porch railings and metal balustrades shall be No. 12 Spruce Green.

#### (C) UNPAINTED STONE AND MASONRY BUILDINGS

Trim with No. 12 Spruce Green in the same manner as for white buildings. It is best to avoid the painting of masonry where possible.

#### (D) LIGHT TOWER AND LANTERN HOUSE (wood, steel or masonry)

The tower and connecting buildings shall be painted as specified in the Light List. The trim on the tower shall remain the same color as at present.

#### (E) ROOFS AND FOUNDATIONS

Roofs, where painted, shall be No. 26 Tile Red. Concrete foundations, if painted, are to be No. 19 Light Gray.

#### (F) MISCELLANEOUS STRUCTURES

Miscellaneous structures, towers and details such as lampposts, fence posts and rails, clothes poles, waste cans, etc. shall be painted white if a wooden surface and No. 12 Spruce Green if a metal surface. Flag poles are an exception and shall always be painted white, unless constructed of corrosion resistant metal which shall remain unpainted.

#### (G) TANKS

Water tanks (metal) whether on ground level or atop a structure shall be painted white on all exterior surfaces including roof. Wood structures supporting a water tank shall be white; metal structures shall be No. 12 Spruce Green.

Large storage tanks (over 1,000 gals. capacity) containing flammable liquids are to be painted No. 12 Spruce Green and shall have the name of the contents painted in large No. 14 Brilliant Yellow letters on the exterior of the tank in a conspicuous location. Smaller containers for flammable liquids or gases shall be painted No. 14 Brilliant Yellow overall with the contents conspicuously indicated in large black letters. This would also apply to paint lockers.

Large flammable liquid storage tanks in tropical and semi-tropical areas may be painted aluminum to reduce heat absorption.

#### (H) TRAFFIC AREAS (where painted)

Traffic areas such as porches, stair treads and risers, platforms and catwalks shall be

### 3-4-2

No. 19 Light Gray. Railings and balustrades attached to buildings shall be painted white if of wood and No. 12 Spruce Green if of metal. Railings and balustrades not attached to a building shall be painted No. 19 Light Gray. No. 20 Medium Gray may be used as an alternate for No. 19 Light Gray where maintenance is unusually difficult.

#### (I) OUTDOOR MACHINERY AND EQUIPMENT

Winches, cranes and other outdoor machinery and equipment shall be painted No. 20 Medium Gray. See Section 3-11.

### 3-4-2, INTERIOR COLORS FOR STATIONS (LIGHT)

Note: Shore Units use Interior Latex Emulsion Paint, except in sanitary spaces.

#### (A) CEILINGS

Ceilings are to be white throughout.

#### (B) TRIM

Trim including baseboards, window frames, window and door sash and doors shall be white, No. 19 Light Gray, or matching color. Fixed equipment against walls such as cabinets shall be in either the wall or trim color. White is preferred for trim especially in dwellings. No. 19 Light Gray may be used as an alternate where maintenance is difficult as in generator rooms or shops. Where the No. 19 Light Gray is used for trim, window sash shall be in the wall color.

#### (C) SLEEPING QUARTERS

In barracks and sleeping quarters Principle A (No. 1 Light Green) and Principle E (No. 23 Turquoise) are recommended for hot climates or for areas having south or west exposure. Principle C (No. 25 Beach Sand), Principle D (No. 4 Soft Yellow) and Principle F (No. 6 Ivory) are recommended for cold climates, for spaces deprived of good natural light or for north and east exposure.

#### (D) LIVING ROOMS

Living rooms, wardrooms, day rooms and parlors are allowed a maximum number of color schemes to provide for wide latitude in

functional and decorative effect. Principle A (No. 1 Light Green) and Principle E (No. 23 Turquoise) impart a cool and fresh atmosphere. These colors are best in warm or moderate climates or for south or west exposures. Principle C (No. 25 Beach Sand) and Principle D (No. 4 Soft Yellow) are warm in tone and will help compensate for low average temperatures or for north or east exposures. Principle G (No. 2 Medium Green) and Principle H (No. 7 Coral) are deeper in tone and should be restricted to casual areas in which difficult eye tasks are not performed. Principle F (No. 6 Ivory) is a general purpose color scheme suitable in all environments and where natural or artificial light is weak. Principle J (No. 9 Pearl Gray with No. 23 Turquoise end wall), Principle K (No. 9 Pearl Gray with No. 4 Soft Yellow end wall) and Principle L (No. 9 Pearl Gray with No. 7 Coral end wall), have a unique decorative effect. In each instance the colored wall should be at the end or far side of the room and never on a wall with windows.

#### (E) OFFICES, OPERATIONS ROOMS AND RADIO ROOMS

Offices, operations rooms and radio rooms may take a variety of color effects: Principle A (No. 1 Light Green) or Principle B (No. 9 Pearl Gray) for south and west exposures; Principle C (No. 25 Beach Sand) or Principle F (No. 6 Ivory) for north and east exposures.

#### (F) DINING ROOMS, MESS HALLS, AND RECREATION ROOMS

For dining rooms, mess halls, recreation rooms, lounges Principle C (No. 25 Beach Sand) or Principle H (No. 7 Coral) are good as they provide a cheerful and appetizing effect. For a cool effect Principle A (No. 1 Light Green) may be used. Principle G (No. 2 Medium Green) and Principle E (No. 23 Turquoise) may also be applied.

#### (G) SANITARY SPACES

The use of Principle I (white) in kitchens, pantries, sculleries, heads, and shower rooms will insure cleanliness and high standards of

housekeeping. In white heads, partitions shall be No. 19 Light Gray with No. 23 Turquoise doors. As an alternate to white, heads and showers in barracks may be painted Principle O (No. 1 Light Green with No. 2 Medium Green dado and trim). Galleys, kitchens and sanitary spaces in family quarters may be painted Principle C, F or D, depending upon the color scheme adopted by the District.

#### (H) STAIRWAYS AND PASSAGEWAYS

Stairways and passageways should be either Principle D (No. 4 Soft Yellow), Principle F (No. 6 Ivory) or Principle I (white). Soffits (under side) of stairs and landings shall be painted white. For practical reasons, stair treads, risers, stringers and balustrades may be No. 19 Light Gray.

#### (I) UTILITY AND STORAGE SPACES

Basements, furnace rooms, battery rooms, generator rooms, emergency power rooms, laundries, miscellaneous storerooms and closets shall be painted Principle I (white).

#### (J) SHOPS

Small general purpose shops shall be Principle A (No. 1 Light Green) or Principle D (No. 4 Soft Yellow).

#### (K) GARAGES

When painting is deemed necessary, the interior shall be Principle P (No. 4 Soft Yellow with No. 19 Light Gray dado and trim). Storage sheds shall be Principle I (white).

#### (L) TOWER INTERIOR

The light house tower interior, including the lens room, shall be white. The metal ladder shall be No. 19 Light Gray. The narrow hazardous portion of winder steps should be painted No. 14 Brilliant Yellow. Miscellaneous metal railings, metal sash, lens frames and supports shall also be No. 19 Light Gray. As an alternate No. 12 Spruce Green may be used.

#### (M) EQUIPMENT AND MACHINERY

Most equipment and machinery at Light Stations including desks, filing cabinets, benches, bins, racks, shelving, etc. shall be No. 30 Equipment Gray unless otherwise specified. For equipment where rougher work is involved, maintenance difficult and cleanliness not essential, such as battery racks, tool racks and bins, use No. 20 Medium Gray.

For the finishing and highlighting of machinery see Section 3-17, Machinery Colors.

#### (N) FLOORS

Natural wood floors shall be sealed and waxed. Painted wooden floors shall normally be No. 19 Light Gray. Where maintenance is difficult, such as in shops, No. 20 Medium Gray may be used as an alternate. Painted floors of galleys, heads, furnace rooms, generator rooms and locker rooms shall be No. 26 Tile Red. Concrete floors shall be left unpainted unless required to correct unsightly appearance.





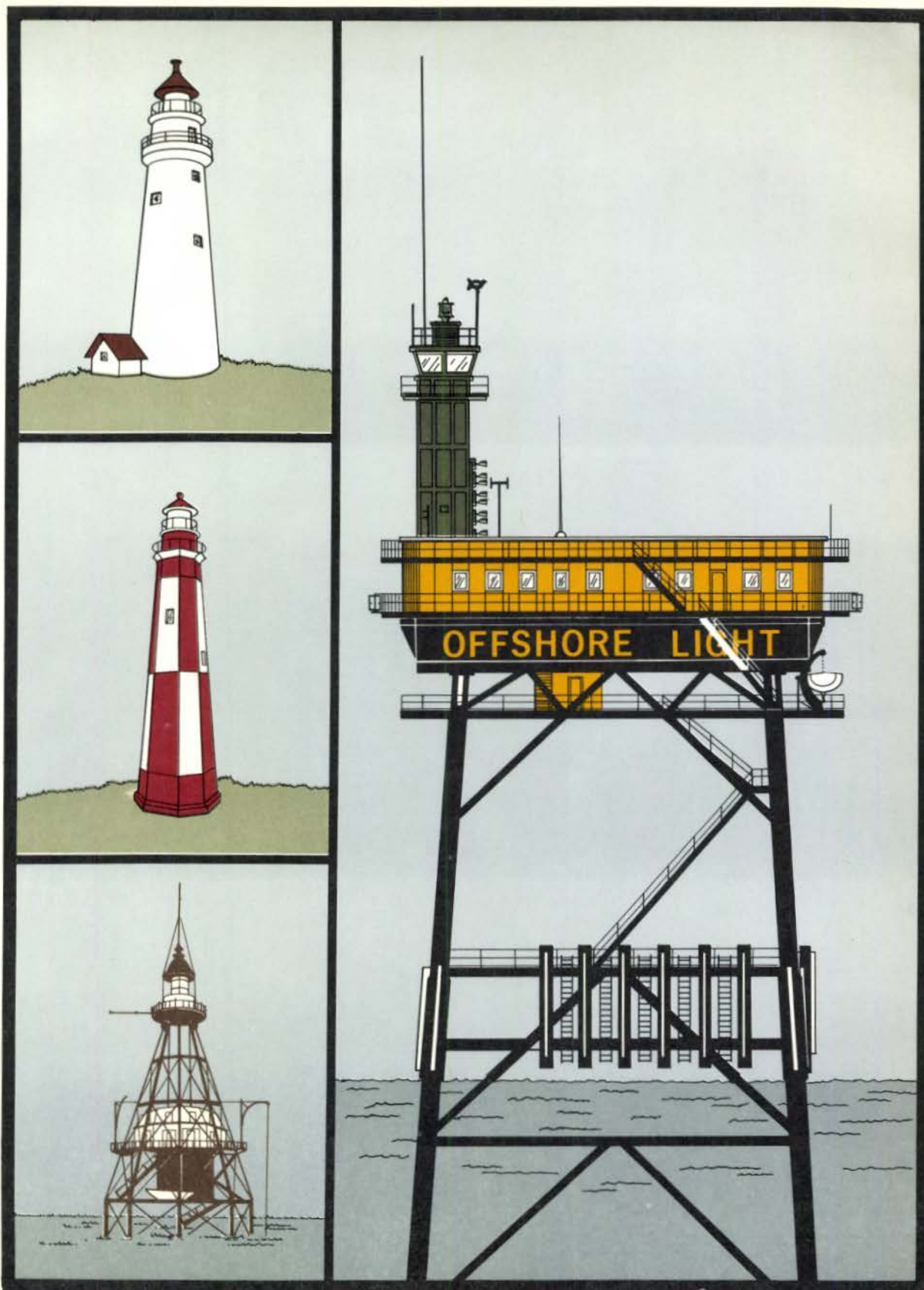



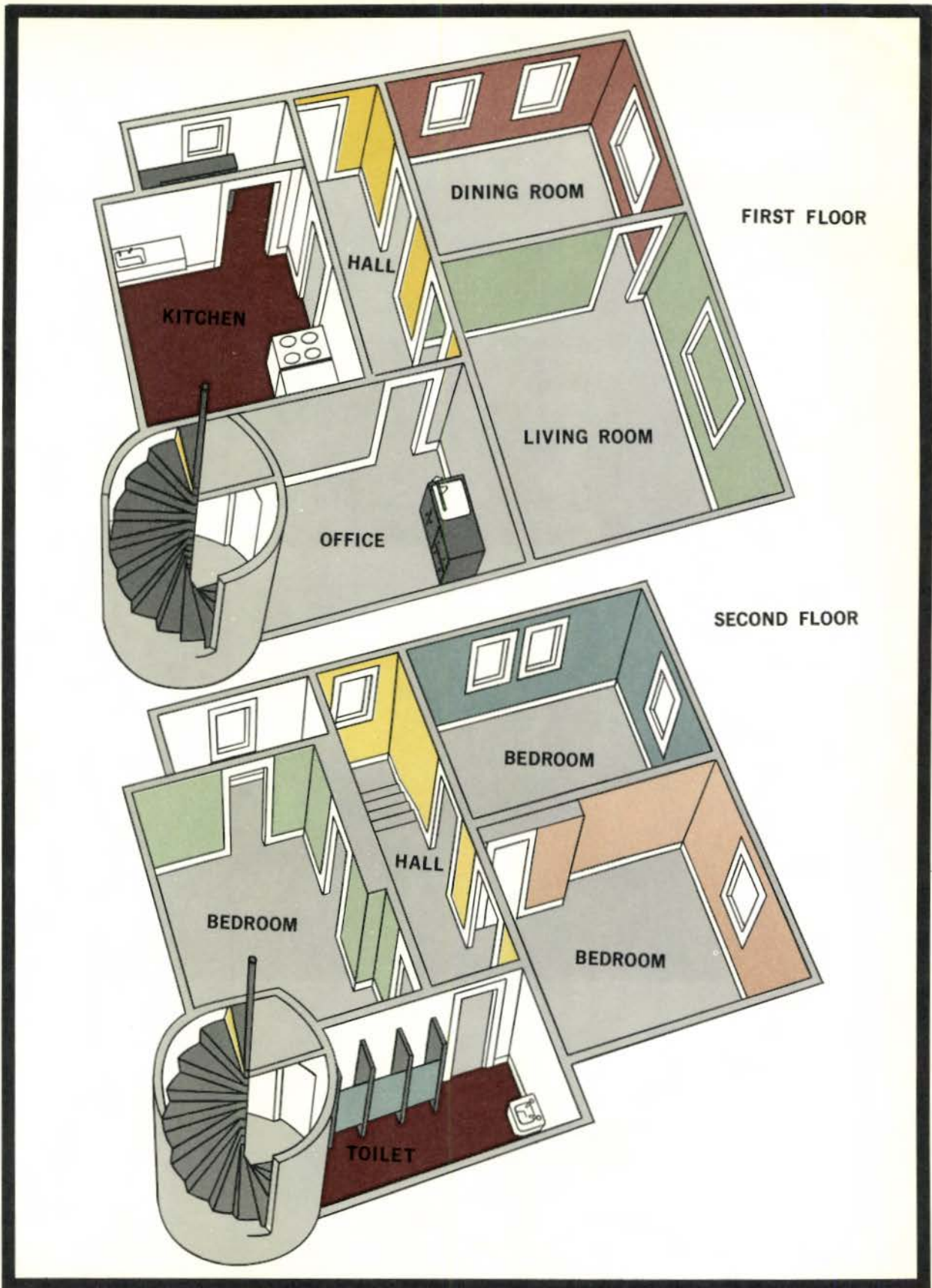



## SECTION 3-5, COLORS FOR STATIONS (RESCUE)

### 3-5-1, EXTERIOR COLORS FOR STATIONS (RESCUE)

#### (A) WOOD, METAL AND PAINTED MASONRY BUILDINGS

The exteriors of buildings shall be painted white, including siding, eaves, gutters and downspouts (where painted), wood porch enclosures, wood porch railings and wood stair structures and balustrades. Trim shall be No. 12 Spruce Green. This includes window sash, shutters, doors, trellis under porches, roof vents, weather vanes, storm doors and windows, metal porch railings and metal stair structures and metal balustrades. Ornamental iron may be black.

In high glare regions such as the tropics or continued snow-covered northern sites, all pertinent buildings at each station may be painted No. 11 Sun Tan to reduce glare. Where this standard is used, trim as above using No. 12 Spruce Green for trim and grade beam.

#### (B) RED BRICK BUILDINGS

White shall be used as a trim color on window sash, shutters, doors, eaves, gutters and downspouts (where painted), wood columns, wood balustrades, wood ornamentation, storm doors, storm windows and trellis under porches. Metal porch railings and metal balustrades shall be No. 12 Spruce Green.

#### (C) UNPAINTED STONE AND MASONRY BUILDINGS

Trim with No. 12 Spruce Green in the same manner as for white buildings. It is best to avoid the painting of masonry where possible.

#### (D) ROOFS AND FOUNDATIONS

Roofs, where painted, shall be No. 26 Tile Red. Concrete foundations, if painted, are to be No. 19 Light Gray.

#### (E) MISCELLANEOUS STRUCTURES

Miscellaneous structures, lookout towers, light towers, flag towers, storm warning towers,

range light towers, drill poles, lampposts, fence posts and rails, clothes poles, waste cans, etc., shall be painted white if a wooden surface and No. 12 Spruce Green if a metal surface. Flag poles are an exception and shall always be painted white unless of corrosion resistant material.

#### (F) TANKS

All exposed exterior surfaces of water tanks (metal) whether on ground level or atop a structure shall be painted white. Wood structures supporting a water tank shall be white; metal structures shall be No. 12 Spruce Green.

Large storage tanks (over 1,000 gals. capacity) containing flammable liquids are to be painted No. 12 Spruce Green and shall have the name of the contents painted in large No. 14 Brilliant Yellow letters on the exterior of the tank in a conspicuous location. Smaller containers for flammable liquids or gases, also paint lockers, shall be painted No. 14 Brilliant Yellow overall with the contents conspicuously indicated in large black letters.

Large flammable liquid storage tanks in tropical and semi-tropical areas may be painted aluminum to reduce heat absorption.

#### (G) TRAFFIC AREAS (where painted)

Traffic areas such as porches, stair treads and risers, platforms and catwalks shall be painted No. 19 Light Gray. Railings and balustrades attached to buildings shall be painted white if of wood and No. 12 Spruce Green if of metal. No. 20 Medium Gray may be used as an alternate where maintenance is unusually difficult. This applies to launchways, metal catwalks, loading docks, piers and adjacent railings and stairways.

#### (H) OUTDOOR MACHINERY AND EQUIPMENT

Boat cradles, winches, cranes and other outdoor machinery and equipment shall be painted No. 20 Medium Gray. See Section 3-11.

### 3-5-2

#### (I) IDENTIFICATION FROM THE AIR

If station has identification marker to be seen from the air, numerals shall be No. 14 Brilliant Yellow on a black background, with broad line underneath to indicate top and bottom. Fire protection equipment, painted No. 13 Fire Red, shall be located near helicopter landing area for safety purposes.

### 3-5-2, INTERIOR COLORS FOR STATIONS (RESCUE)

Use Interior Synthetic Latex Emulsion Paint, except in sanitary spaces.

#### (A) CEILINGS

Ceilings are to be white throughout except in lookout towers.

#### (B) TRIM

Trim including baseboards, window frames, window and door sash and doors, shall be white or No. 19 Light Gray. Fixed equipment against walls such as cabinets shall be in either the wall or trim color. White is preferred for trim especially in dwellings. No. 19 Light Gray may be used as an alternate where maintenance is difficult as in boat houses, garages, repair shops. Where the No. 19 Light Gray is used for trim, window sash shall be in the wall color.

#### (C) SLEEPING QUARTERS

In bedrooms and sleeping quarters Principle A (No. 1 Light Green) and Principle E (No. 23 Turquoise) are recommended for hot climates or for areas having south or west exposures. Principle C (No. 25 Beach Sand), Principle D (No. 4 Soft Yellow) and Principle F (No. 6 Ivory) are recommended for cold climates, for spaces deprived of good natural light or for north and east exposures.

#### (D) LIVING ROOMS AND DAY ROOMS

Living rooms, day rooms, wardrooms and parlors are allowed a maximum number of color schemes to provide for wide latitude in functional and decorative effect. Principle A (No. 1 Light Green) and Principle E (No. 23 Turquoise) impart a cool and fresh atmosphere. These colors are best in warm or moderate climates or for south or west ex-

posures. Principle C (No. 25 Beach Sand) and Principle D (No. 4 Soft Yellow) are warm in tone and will help compensate for low average temperatures or for north or east exposures. Principle G (No. 2 Medium Green) and Principle H (No. 7 Coral) are deeper in tone and should be restricted to casual areas in which difficult eye tasks are not performed. Principle F (No. 6 Ivory) is a general purpose color scheme suitable in all environments and where natural or artificial light is weak. Principle J (No. 9 Pearl Gray with No. 23 Turquoise end wall), Principle K (No. 9 Pearl Gray with No. 4 Soft Yellow end wall) and Principle L (No. 9 Pearl Gray with No. 7 Coral end wall), have a unique decorative effect. In each instance the colored wall should be at the end or far side of the room and never on a wall with windows.

#### (E) DINING ROOMS, MESS HALLS, AND RECREATION ROOMS

For dining rooms, mess halls, lounges and recreation rooms Principle C (No. 25 Beach Sand) or Principle H (No. 7 Coral) are good as they provide a cheerful and appetizing effect. For a cool effect Principle A (No. 1 Light Green) may be used. Principle G (No. 2 Medium Green) and Principle E (No. 23 Turquoise) may also be applied.

#### (F) BOAT HOUSES, OFFICES, OPERATIONS ROOMS

In boat houses and garages Principle P shall be used (No. 4 Soft Yellow with No. 19 Light Gray trim). Offices, operations rooms, communication rooms, and radio rooms may take a variety of color effects: Principle A, (No. 1 Light Green) or Principle B, (No. 9 Pearl Gray) for south and west exposures; Principle C (No. 25 Beach Sand) or Principle F (No. 6 Ivory) for north and east exposures. In the lookout tower No. 1 Light Green (Principle A), illustrated, shall be applied to walls and overhead to reduce glare.

#### (G) SANITARY SPACES

The use of Principle I (White) in kitchens, pantries, sculleries, heads and shower rooms will insure cleanliness and high standards of housekeeping. In white heads, partitions

shall be No. 19 Light Gray with No. 23 Turquoise doors. As an alternate to white, heads and showers in barracks may be painted Principle O (No. 1 Light Green with No. 2 Medium Green dado and trim). Kitchens and sanitary spaces in family quarters may be painted Principle C, F or D, depending upon the color scheme adopted by the District.

#### (H) STAIRWAYS AND HALLWAYS

Stairways and hallways shall be either Principle D (No. 4 Soft Yellow), Principle F (No. 6 Ivory) or Principle I (white). Soffits (under side) of stairs and landings shall be painted white. For practical reasons, stair treads, risers, stringers and balustrades may be No. 19 Light Gray. No. 14 Brilliant Yellow may be painted on top and bottom risers for purposes of safety.

#### (I) UTILITY AND STORAGE SPACES

Basements, furnace rooms, battery rooms, generator rooms, emergency power rooms, laundries, miscellaneous storerooms and closets shall be painted Principle I (white), illustrated.

#### (J) SHOPS

Small general purpose shops shall be Prin-

ciple O (No. 1 Light Green with No. 2 Medium Green trim) or Principle P (No. 4 Soft Yellow with No. 19 Light Gray trim).

#### (K) EQUIPMENT AND MACHINERY

Most equipment at Rescue Stations including desks, filing cabinets, benches, bins, racks, shelving, etc. shall be No. 30 Equipment Gray unless otherwise specified. For equipment where rougher work is involved, maintenance difficult and cleanliness not essential, such as metal working machinery, winches, boat cradles, engines, motors, tool racks and bins, use No. 20 Medium Gray (Federal 16187).

For the finishing and highlighting of machinery see Sections 3-17.

#### (L) FLOORS

Wood floors in a natural finish shall be sealed and waxed. Painted floors shall normally be No. 19 Light Gray. Where maintenance is difficult, such as in shops, No. 20 Medium Gray may be used as an alternate. Painted floors of kitchens, heads, furnace rooms, generator rooms and locker rooms shall be No. 26 Tile Red. Concrete floors should be left unpainted unless required to correct unsightly appearance.





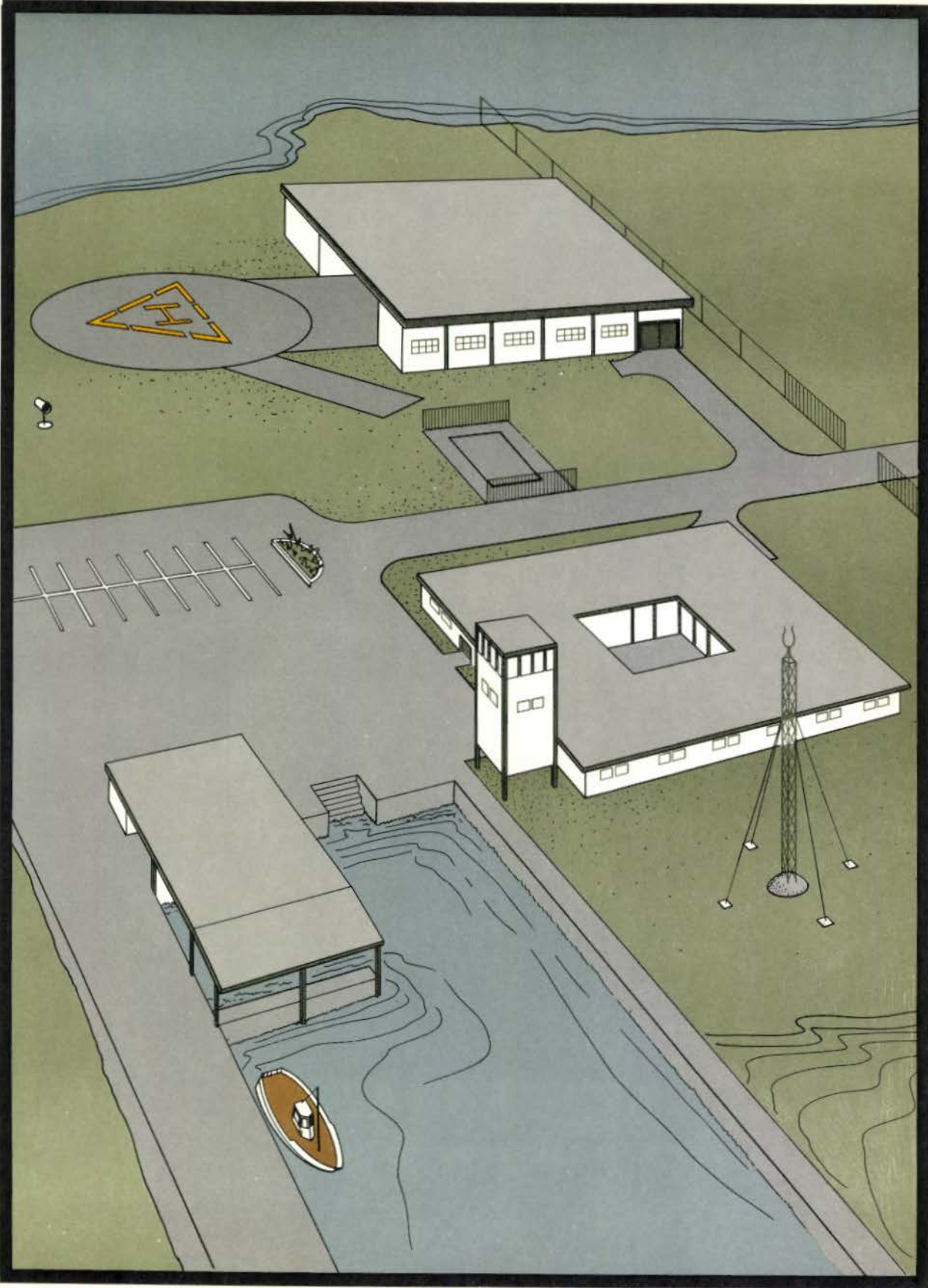



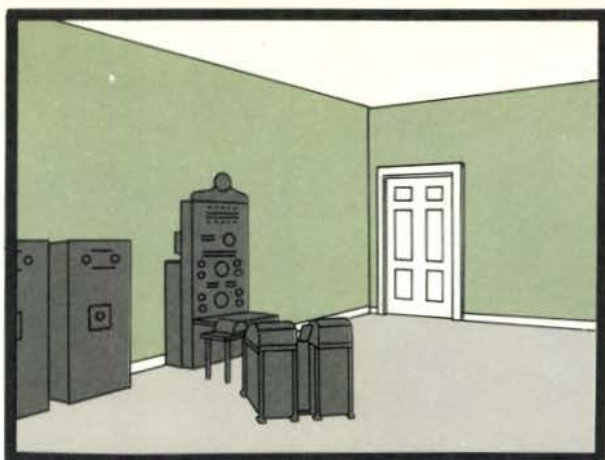

Operations centers and communications rooms are highly desirable in Principle A, No. 1 Light Green.

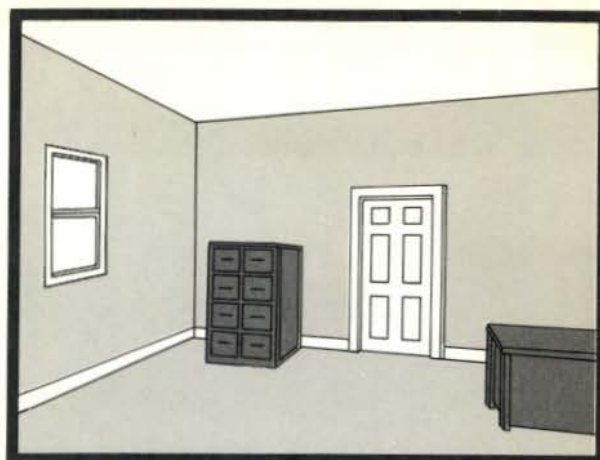

Offices may be Principle B, No. 9 Pearl Gray where a cool and non-distracting environment is wanted.



Barracks, living areas, recreation rooms should be in cheerful colors such as No. 23 Turquoise.

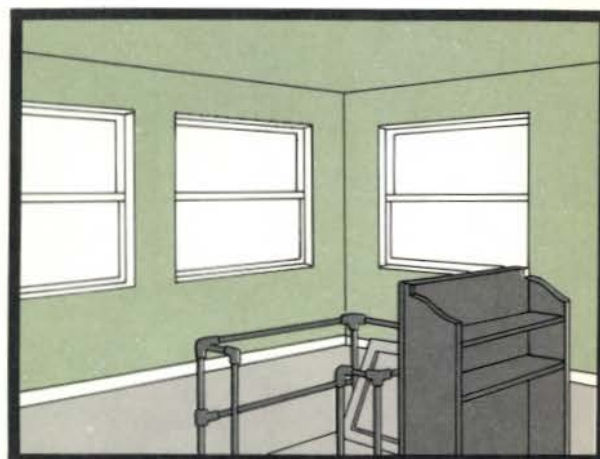

Although most ceilings should be white, in the lookout tower No. 1 Light Green should be applied throughout.



Boat house and garage interiors should be Principle P, No. 19 Light Gray dado and trim with No. 4 Soft Yellow walls.

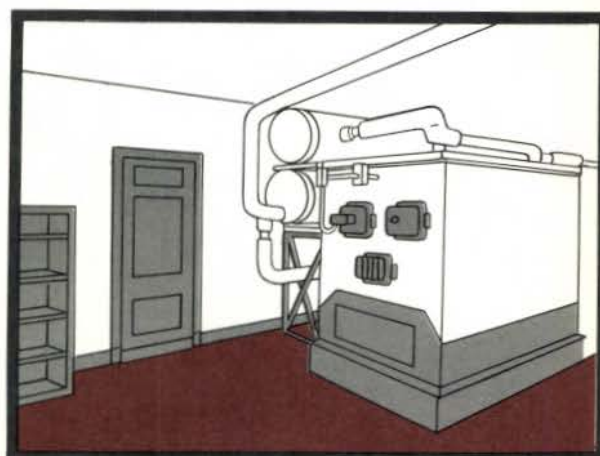

Furnace rooms should be Principle R with white walls and No. 19 Light Gray trim. No. 26 Tile Red floors (if painted).



## SECTION 3-6, COLORS FOR RADIO AND LORAN STATIONS

The below instructions are also applicable to Radiobeacon Stations,  
Loran Monitor Stations and Electronics Engineering Stations

### 3-6-1, EXTERIOR COLORS FOR RADIO AND LORAN STATIONS

#### (A) WOOD, METAL AND

##### PAINTED MASONRY BUILDINGS

The exteriors of buildings shall be painted white, including siding, eaves, gutters and downspouts (where painted), wood porch enclosures, wood porch railings and wood stair structures and balustrades. Top and bottom risers on outdoor stairs may be painted No. 14 Brilliant Yellow for purposes of safety. Trim shall be No. 12 Spruce Green. This includes window sash, shutters, doors, trellis under porches, roof vents, weather vanes, storm doors and windows, metal porch railings, metal stair structures and metal balustrades. Ornamental iron may be black.

In high glare regions such as the tropics or continued snow covered northern sites, all pertinent buildings at each station may be painted No. 11 Sun Tan to reduce glare. Where this standard is used, trim as above using No. 12 Spruce Green for trim and grade beam.

#### (B) RED BRICK BUILDINGS

White shall be used as a trim color on window sash, shutters, doors, eaves, gutters and downspouts (where painted), wood columns, wood balustrades, wood ornamentation, storm doors, storm windows and trellis under porches. Metal porch railings and metal balustrades shall be No. 12 Spruce Green.

#### (C) UNPAINTED STONE AND MASONRY BUILDINGS

Trim with No. 12 Spruce Green in the same manner as for white buildings. It is best to avoid the painting of masonry where possible.

#### (D) SHEET METAL CLAD BUILDINGS

Exterior surfaces of sheet metal clad buildings shall not be painted.

#### (E) ROOFS AND FOUNDATIONS

Roofs where painted, shall be No. 26 Tile Red. Concrete foundations, if painted, are to be No. 19 Light Gray.

#### (F) MISCELLANEOUS STRUCTURES

Miscellaneous structures, towers and details such as lampposts, fence posts and rails, clothes poles, waste cans, etc. shall be painted white if a wooden surface and No. 12 Spruce Green if a metal surface. Flag poles are an exception and shall always be painted white unless of corrosion-resistant metal which can be left unpainted.

In remote forward areas creosoted structures need not be painted.

#### (G) TANKS

Water tanks (metal) shall be painted white on the sides and the roof. Wood structures supporting a water tank shall be white; metal structures shall be No. 12 Spruce Green. Wood water tanks shall not be painted.

Large storage tanks (over 1,000 gals. capacity) containing flammable liquids are to be painted No. 12 Spruce Green and shall have the name of the contents painted in large No. 14 Brilliant Yellow letters on the exterior of the tank in a conspicuous location. Smaller containers for flammable liquids or gases, also paint lockers, shall be painted No. 14 Brilliant Yellow overall with the contents conspicuously indicated in large black letters.

Large flammable liquid storage tanks in tropical and semi-tropical areas may be painted aluminum to reduce heat absorption.

### 3-6-1

#### (H) HAZARDS TO AIR NAVIGATION

Tall structures, water tanks, towers, poles, antennas, etc. frequently represent a hazard to air navigation. Where this is true, the latest Federal Aviation Agency publication "Obstruction Marking and Lighting" should be consulted for the proper painting procedures. This publication may be obtained from the Superintendent of Documents, Government Printing Office, Washington D.C. 20402. Briefly, on tall towers and antenna poles alternate bands of No. 18 International Orange and white shall be applied throughout their height and the terminating bands at top and bottom shall be orange. The width of the orange bands shall be approximately one-seventh the height of the structure, and the alternate white bands shall be equal to the width of the orange bands. However, the orange bands shall never be more than 40 ft. nor less than 1½ ft. On large flat surfaces a checkerboard pattern is used. The sides of the squares or rectangles shall not measure more than 20 ft. nor less than 5 ft. (Night lighting is required for all tall structures.)

#### (I) TRAFFIC AREAS

Traffic areas such as porches, stair treads and risers, platforms and catwalks shall be No. 19 Light Gray. Railings and balustrades attached to buildings shall be painted white if of wood and No. 12 Spruce Green if of metal. Railings and balustrades not attached to buildings shall be painted No. 19 Light Gray. No. 20 Medium Gray may be used as an alternate for No. 19 Light Gray where maintenance is unusually difficult. This applies to catwalks, loading docks, piers, and adjacent railings and stairways.

#### (J) OUTDOOR MACHINERY AND EQUIPMENT

Winches, cranes and other outdoor machinery and equipment shall be painted No. 20 Medium Gray (Federal 16187). See Section 3-11.

### 3-6-2, INTERIOR COLORS FOR RADIO AND LORAN STATIONS

#### (A) CEILINGS

Ceilings are to be white throughout except

as indicated in below paragraph entitled, "Areas Requiring Low Light Levels."

#### (B) TRIM

Trim including baseboards, window frames, window and door sash and doors shall be white or No. 19 Light Gray. Fixed equipment against walls such as cabinets should be in either the wall or trim color. White is preferred for trim especially in dwellings. No. 19 Light Gray may be used as an alternate where maintenance is difficult as in garages and repair shops. Where the No. 19 Light Gray is used for trim, window sash should be in the wall color.

#### (C) SLEEPING QUARTERS

See Sleeping Quarters, Article 3-5-2(C).

#### (D) LIVING ROOMS AND DAY ROOMS

See Living Rooms and Day Rooms, Article 3-5-2(D).

#### (E) DINING ROOMS, MESS HALLS, AND RECREATION ROOMS

See Dining Rooms, Mess Halls, and Recreation Rooms, Article 3-5-2(E).

#### (F) OFFICES

Office areas should be Principle A (No. 1 Light Green) or Principle B (No. 9 Pearl Gray) for warm climates or for south or west exposures. Principle C (No. 25 Beach Sand, or Principle F (No. 6 Ivory) should be used where a warm effect is wanted, as for north and east exposures. In all cases trim shall be No. 19 Light Gray.

#### (G) OPERATIONS AREAS

In operations rooms, broadcasting rooms, transmitting rooms, control rooms and radio rooms, Principle A (No. 1 Light Green), illustrated, shall be used. This soft, cool color will assure a comfortable and efficient seeing condition.

#### (H) AREAS REQUIRING LOW LIGHT LEVELS

At Radio and Loran Stations, certain areas call for low levels of illumination to aid the visibility of dials and scopes. This condition is frequently required for Loran timer rooms

and supervisor's rooms. Light sources should be properly controlled and shielded. White ceilings will present no problem if illumination is well subdued. Principle G (No. 2 Medium Green) should normally be used and the color may be carried on trim and overhead if desired. In very cold climates, Principle H (No. 7 Coral) may be applied. Principle B (No. 9 Pearl Gray, with trim in No. 19 Light Gray), may be used on walls and overhead as an alternate for either of the above color schemes.

#### (I) SANITARY SPACES

The use of Principle I (white) in kitchens, pantries, sculleries, heads and shower rooms will insure cleanliness and high standards of housekeeping. In white heads, partitions shall be No. 19 Light Gray with No. 23 Turquoise doors. As an alternate to white, heads and showers in barracks may be painted Principle O (No. 1 Light Green with No. 2 Medium Green dado and trim). Galleys, kitchens and sanitary spaces in family quarters may be painted Principle C, F or D, depending upon the color scheme adopted by the District.

#### (J) STAIRWAYS AND HALLWAYS

Stairways and hallways shall be Principle D (No. 4 Soft Yellow), Principle F (No. 6 Ivory) or Principle I (white). Soffits (under side) of stairs and landings shall be painted white. For practical reasons, stair treads, risers, stringers and balustrades may be No. 19 Light Gray.

#### (K) UTILITY AND STORAGE SPACES

Basements, furnace rooms, battery rooms, generator rooms, emergency power rooms, laundries, miscellaneous storerooms and closets shall be painted Principle I (white).

#### (L) SHOPS

Small general purpose shops shall be Principle O (No. 1 Light Green with No. 2 Medium Green trim) or Principle P (No. 4 Soft Yellow with No. 19 Light Gray trim).

#### (M) EQUIPMENT

Most equipment including desks, filing cabinets, benches, bins, racks, shelving, etc. shall be No. 30 Equipment Gray unless otherwise specified. For equipment where rougher work is involved, maintenance difficult and cleanliness not essential, such as metal working machinery, engines, motors, tool racks and bins use No. 20 Medium Gray (Federal 16187).

For the finishing and highlighting of machinery see Section 3-17.

#### (N) FLOORS

Wood floors with a natural finish shall be sealed and waxed. Painted floors shall normally be No. 19 Light Gray. Where maintenance is difficult, such as in shops, No. 20 Medium Gray may be used as an alternate. Painted floors of galleys, heads, furnace rooms, generator rooms and locker rooms shall be No. 26 Tile Red. For concrete floors see Article 3-5-2(L).





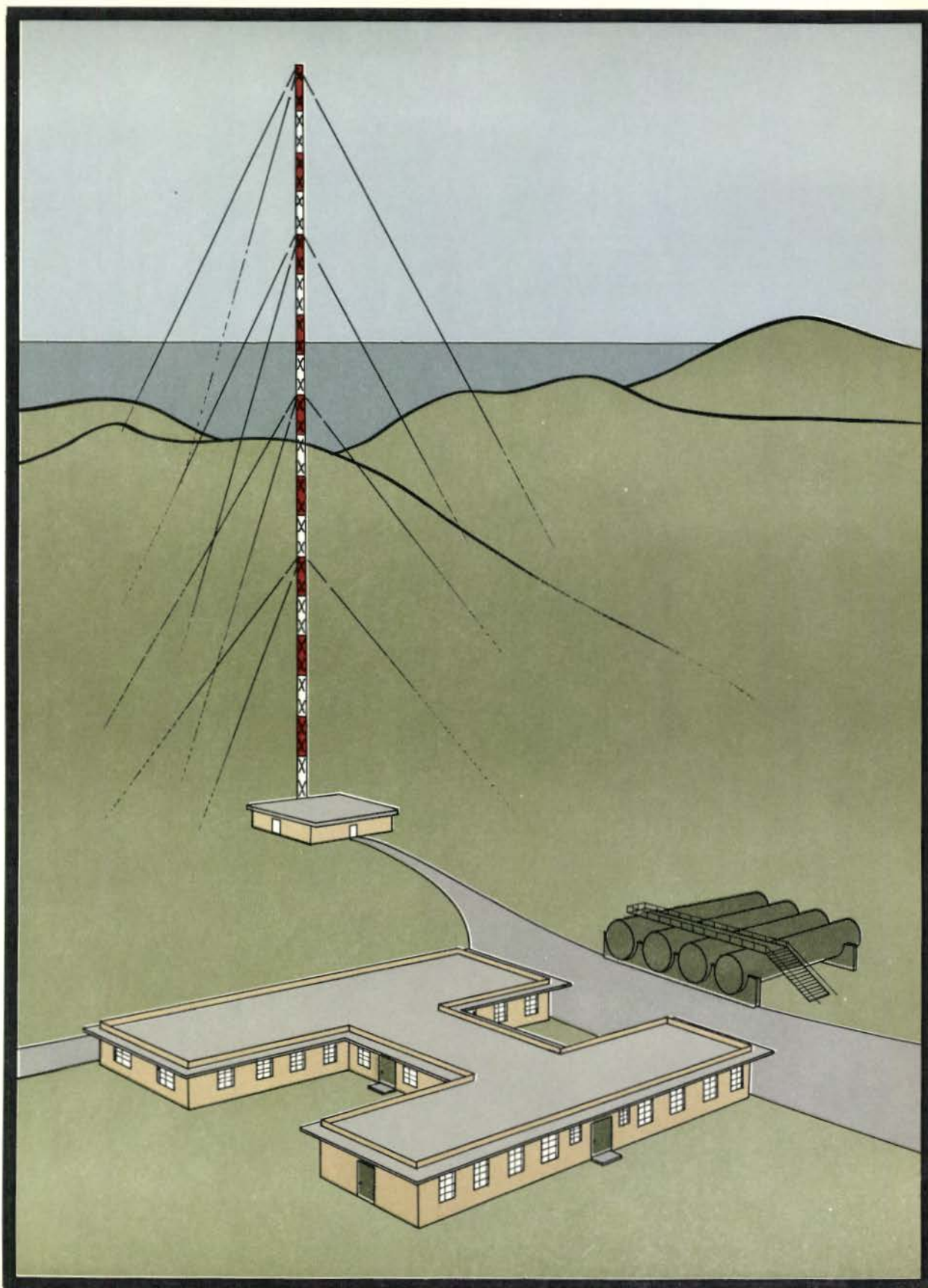



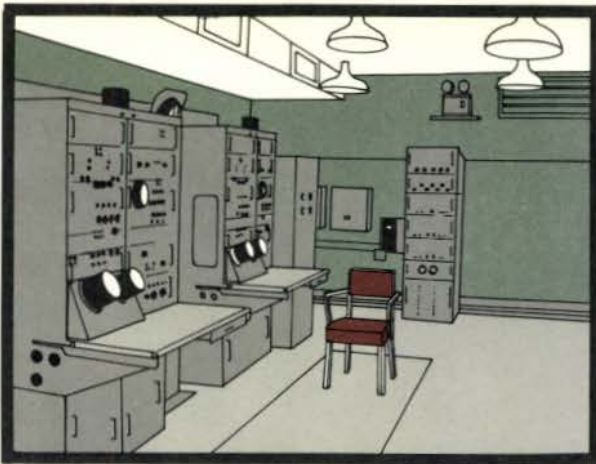

Where dim light levels are maintained, such as in Timer Rooms, Principle G, No. 2 Medium Green, should be used.

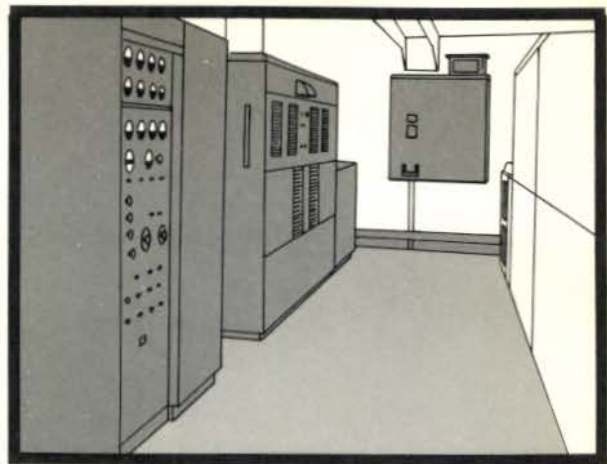

In Transmitter Rooms, walls can be No. 6 Ivory or white for good light reflectance and maintenance.

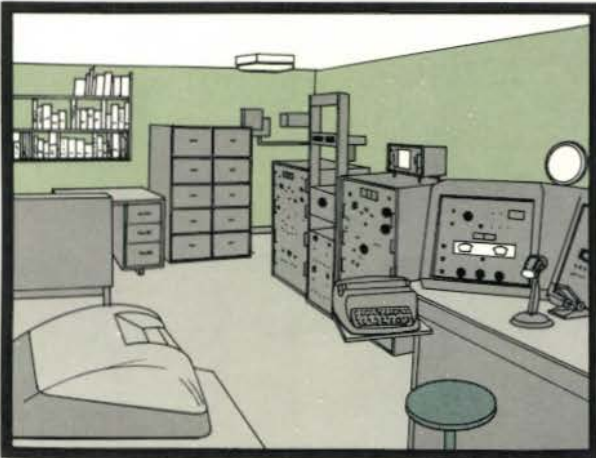

Radio Rooms should be in Principle A which uses No. 1 Light Green for walls for a cool and restful effect.

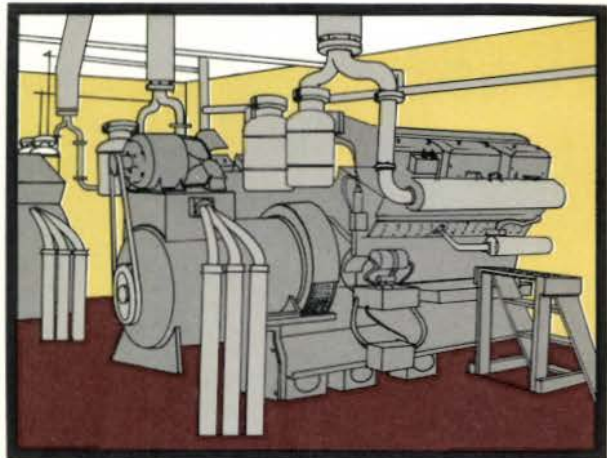

Principle P is recommended for Generator Rooms, with gray machinery and No. 26 Tile Red floor.



Offices could be No. 25 Beach Sand where climate is cool — or No. 1 Light Green for a warm climate.

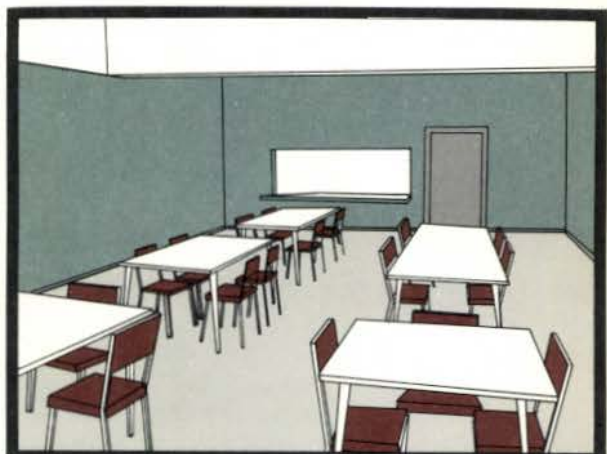

Mess halls and recreation spaces in No. 23 Turquoise will provide an agreeable relief to personnel.



## SECTION 3-7, COLORS FOR AIR STATIONS

The below instructions are also applicable to  
Aircraft Repair and Supply Bases

### 3-7-1, EXTERIOR COLORS FOR AIR STATIONS

#### (A) WOOD, METAL AND PAINTED MASONRY BUILDINGS

See Article 3-4-1(A).

#### (B) RED BRICK BUILDINGS

See Article 3-4-1(B).

#### (C) UNPAINTED STONE AND MASONRY BUILDINGS

See Article 3-4-1(C).

#### (D) ROOFS AND FOUNDATIONS

Roofs (where painted), other than hangar roofs, shall be No. 26 Tile Red. Hangar roofs which are lettered U. S. COAST GUARD and which have directional arrows or other symbols shall be No. 19 Light Gray if painted. The lettering and directional arrow shall be No. 14 Brilliant Yellow with a heavy black outline or background. Where there is a bituminous roof, the lettering shall be No. 14 Brilliant Yellow only. For instructions on roof markings, when so authorized, refer to current Federal Aviation Agency "Air Marking Guide," obtainable from the Inquiry Branch, Federal Aviation Agency, Washington, D. C. 20553.

Concrete foundations, if painted, are to be No. 19 Light Gray.

#### (E) MISCELLANEOUS STRUCTURES

See Article 3-4-1(F).

#### (F) TANKS

Water tanks (metal) whether on ground level or atop a structure shall be painted white on all exterior surfaces. Wood struc-

tures supporting a water tank shall be white; metal structures shall be No. 12 Spruce Green.

Large storage tanks (over 1,000 gals. capacity) containing flammable liquids are to be painted No. 12 Spruce Green and shall have the name of the contents painted in large No. 14 Brilliant Yellow letters on the exterior of the tank in a conspicuous location. Smaller containers for flammable liquids or gases, also paint lockers, shall be painted No. 14 Brilliant Yellow overall with the contents conspicuously indicated in large black letters.

Large flammable liquid storage tanks in tropical and semi-tropical areas may be painted aluminum to reduce heat absorption.

#### (G) HAZARDS TO AIR NAVIGATION

Tall structures, water tanks, towers, poles, antennas, etc. should be avoided wherever possible at air stations. Where they exist, the latest Federal Aviation Agency publication "Obstruction Marking and Lighting" should be consulted for the proper painting procedures. This publication may be obtained from the Superintendent of Documents, Government Printing Office, Washington, D. C. 20402. Briefly, on tall towers and antenna poles alternate bands of No. 18 International Orange and white shall be applied throughout their height and the terminating bands at top and bottom shall be orange. The width of the orange bands shall be approximately one-seventh the height of the structure and the alternate white bands shall be approximately equal to the width of the orange bands. However, the orange bands shall never be more than 40 ft. nor less than 1½ ft. On large flat surfaces a checkerboard pattern is used. The sides of the squares or rectangles shall not measure more than 20 ft. nor less than 5 ft. (Night lighting is required for all tall structures.)

**(H) RUNWAYS**

Standard marking and numbering is mandatory for airfield runways and taxiways. All markings on runways shall be white and shall have a black background or outline if clear visibility demands. All markings on taxiways should be No. 14 Brilliant Yellow. Detailed information is contained in FAA Advisory Circular AC 150/5340-1, "Marking of Serviceable Runways and Taxiways" and is available from Distribution Section HQ-438, Federal Aviation Agency, Washington, D. C. 20553. The above publication describes and illustrates, in chart form: Basic Runway Markings for visual flight; Instruction Runway Markings for non-visual navigation involving instruments; All-Weather Runway Markings served by non-visual precision approach aids.

**(I) AIR STATION TOWING  
EQUIPMENT AND VEHICLES**

Coast Guard shore equipment and vehicles are described in detail in Sections 3-11 and 3-12. On airfields safety necessitates the prominent identification of certain equipment. No. 14 Brilliant Yellow shall be applied to all types of airfield ground maintenance equipment including gasoline trucks, mules, tractors, transporters, lift and pallet trucks, cranes, tractors, bulldozers and scrapers. Fuel trucks, not used on airfields, may be No. 19 Light Gray with the word FLAMMABLE lettered in No. 14 Brilliant Yellow.

No. 13 Fire Red is the prescribed color for fire trucks and crash and rescue trucks.

**(J) TRAFFIC AREAS**

Traffic areas such as porches, stair treads and risers, platforms and catwalks shall be No. 19 Light Gray. Railings and balustrades attached to buildings shall be painted white if of wood and No. 12 Spruce Green if of metal. Railings and balustrades not attached to buildings shall be painted No. 19 Light Gray. No. 20 Medium Gray may be used as an alternate for No. 19 Light Gray where maintenance is unusually difficult. This applies to catwalks, loading docks, piers, and adjacent railings and stairways.

**(K) OUTDOOR MACHINERY  
AND EQUIPMENT**

Winches, cranes and other outdoor machinery and equipment not used on airfields shall be painted No. 20 Medium Gray. See Section 3-11. Small mobile equipment which may constitute a hazard should be painted No. 14 Brilliant Yellow. See Section 3-12.

**3-7-2, INTERIOR COLORS FOR  
AIR STATIONS****(A) CEILINGS**

Ceilings are to be white throughout.

**(B) TRIM**

Trim including baseboards, window frames, window and door sash, doors, stair balustrades and stringers shall be either white or No. 19 Light Gray. Fixed equipment against the walls such as cabinets shall be in either the wall or trim color unless otherwise specified. White is preferred for trim, especially in living spaces with No. 19 Light Gray used as an alternate where maintenance is difficult as in shops. Where No. 19 Light Gray is used for trim, window sash shall be in the wall color. In either case the selected trim color shall be used uniformly throughout a building or an area in a building.

**(C) BARRACKS AND SLEEPING  
QUARTERS**

In barracks and sleeping quarters Principle A (No. 1 Light Green) and Principle E (No. 23 Turquoise) are recommended for hot climates or for areas having south or west exposures. Principle C (No. 25 Beach Sand), Principle D (No. 4 Soft Yellow) and Principle F (No. 6 Ivory) are recommended for cold climates, for spaces deprived of good natural light or for north and east exposures.

**(D) WARDROOMS**

To provide for wide latitude in functional and decorative effect, wardrooms, are allowed a maximum number of color schemes. Principle A (No. 1 Light Green), Principle B (No. 9 Pearl Gray) and Principle E (No. 23 Turquoise) impart a cool and fresh at-

mosphere. These colors are best in warm or moderate climates. Principle C (No. 25 Beach Sand) and Principle D (No. 4 Soft Yellow) are warm in tone and will help compensate for low average temperatures. Principle G (No. 2 Medium Green) and Principle H (No. 7 Coral) are deeper in tone, colorful and attractive, but not suggested for interiors in which work tasks may be performed. Principle F (No. 6 Ivory) is a general purpose color scheme suitable in all environments. Principle J (No. 9 Pearl Gray with No. 23 Turquoise end wall), Principle K (No. 9 Pearl Gray with No. 4 Soft Yellow end wall) and Principle L (No. 9 Pearl Gray with No. 8 Coral end wall) have a unique decorative effect. In each instance the colored wall should be at the end or far side of the room and never on a wall with windows.

#### (E) OFFICES AND OPERATIONS CENTERS

Offices, Ready Rooms, Briefing Rooms, and Operation Centers may take a variety of color effects: Principle A (No. 1 Light Green) or Principle B (No. 9 Pearl Gray) for south and west exposure; Principle C (No. 25 Beach Sand) or Principle F (No. 6 Ivory) for north and east exposures. In control towers, where glass is widely used, any sash, wall areas and ceilings shall be No. 1 Light Green to curtail glare.

#### (F) RADIO ROOMS AND COMMUNICATIONS CENTERS

Principle A (No. 1 Light Green) or Principle B (No. 9 Pearl Gray) shall be used. These colors have good reflectance for seeing tasks yet insure a restful and glare-free environment.

#### (G) MESS HALLS, CAFETERIAS AND DINING ROOMS

For mess halls and cafeterias Principle C (No. 25 Beach Sand) may be used as it provides a cheerful and appetizing effect. For a cool effect Principle A (No. 1 Light Green) may be used. Either Principle M (No. 25 Beach Sand with No. 7 Coral dado and trim), or Principle O (No. 1 Light Green with No. 2 Medium Green dado and trim) may be selected as alternates.

(H) RECREATION ROOMS, LOUNGES  
A dado is best for recreation rooms. Principle M (No. 25 Beach Sand with No. 7 Coral dado and trim), Principle O (No. 1 Light Green with No. 2 Medium Green dado and trim) may be used. Recommended lounge colors are Principle E (No. 23 Turquoise) or Principle H (No. 7 Coral) for lower wall brightness.

#### (I) SANITARY SPACES

The use of Principle I (white) in kitchens, pantries, sculleries, heads and shower rooms will insure cleanliness and high standards of housekeeping. In white heads, partitions shall be No. 19 Light Gray with No. 23 Turquoise doors. As an alternate to white, heads and showers in barracks may be painted Principle O (No. 1 Light Green with No. 2 Medium Green dado and trim). Kitchens and sanitary spaces in family quarters may be painted Principle C, F or D, depending upon the color scheme adopted by the District.

#### (J) UTILITY SPACES AND STORAGE SPACES

Basements, furnace rooms, battery rooms, generator rooms, emergency power rooms, laundries, stock rooms, spare parts storerooms, closets and locker rooms, shall be painted Principle I (white) or Principle R (white with No. 19 Light Gray dado and trim).

#### (K) STAIRWAYS, CORRIDORS AND PASSAGEWAYS

Stairways, corridors and passageways shall be Principle D (No. 4 Soft Yellow), Principle F (No. 6 Ivory) or Principle I (white). Principle P (No. 4 Soft Yellow with No. 19 Light Gray dado and trim, including stair treads, risers and stringers), may be used in shop areas or where traffic is heavy. To reduce stumbling and falling hazards a 4-in. band of No. 14 Brilliant Yellow shall be applied immediately under the tread on the top and bottom risers. Where the soffits (under side) of stairs and landings are plaster or concrete they should be painted white. The undersides of metal stairs are better in No. 19 Light Gray.

### (L) DISPENSARIES, INFIRMARIES AND SICK BAYS

Where they exist, dispensaries, pharmacies, first aid rooms, treatment rooms and examining rooms shall be Principle I (white) for cleanliness and good light reflection. Principle C (No. 25 Beach Sand) or Principle A (No. 1 Light Green) could be used as alternates. Sick rooms, wards, dental clinics and remainder of the hospital area shall be Principle A (No. 1 Light Green) for a cool effect.

### (M) EXCHANGES

The high popularity of blue among men makes it an ideal color for use in exchange facilities. Where a post exchange may exist, Principle E (No. 23 Turquoise) may be used. As a special effect No. 9 Pearl Gray may be used to provide a soft neutral background for the display of various items sold. No. 23 Turquoise is then used for trim, doors, baseboards, shelving and counters.

For soda fountains and snack bars the appetizing qualities of Principle M (No. 25 Beach Sand with No. 7 Coral dado and trim) may be used. Again, No. 23 Turquoise may be used for counters and No. 26 Tile Red for counter tops.

### (N) HANGARS

Two color schemes are recommended for hangars. The simplest effect is to use white for upper walls and overhead, and No. 19 Light Gray for dado, trim and window sash (Principle R). Wood roof trusses and beams should ordinarily be white. However, steel trusses, beams and girders may be No. 19 Light Gray. A more luminous and bright effect for hangars in colder climates will be found in the use of white for overhead, No. 4 Soft Yellow for upper walls, and No. 19 Light Gray for dado, trim, window sash and steel work (Principle P). It is important to have the good light reflection provided either by white or No. 4 Soft Yellow.

### (O) SHOPS

For machine shops where average tasks are performed, Principle P is recommended. This consists of a white overhead, No. 4 Soft Yellow on upper walls, and No. 19 Light Gray on dado, trim and window sash.

In electronic shops and electrical shops where fairly difficult seeing tasks are performed and where fine tolerances are demanded, Principle O is desirable. Here No. 1 Light Green is used for upper walls, with No. 2 Medium Green for dado, trim and window sash. White with No. 19 Light Gray for dado and trim (Principle R) is proposed for unimportant areas such as tool cribs, storage rooms and locker rooms.

### (P) EQUIPMENT AND MACHINERY

There are two gray standards for equipment: No. 30 Equipment Gray (Federal 16376) and No. 20 Medium Gray (Federal 16187). The lighter tone No. 30 Equipment Gray (Federal 16376) should be used wherever possible. While this fairly light tone of gray requires more maintenance, it does improve workmanship, since it leads to greater cleanliness and care of equipment. Portable testing apparatus, desks, stools, filing cabinets, electrical equipment and fine machine tools should be No. 30 Equipment Gray (Federal 16376) unless otherwise specified. Where rougher machinery and equipment are involved—tool racks, bins, work benches, lathes, drill presses, shapers, milling machines, tool grinders, power saws, etc.—the deeper No. 20 Medium Gray (Federal 16187) is acceptable as an alternate. (For the highlighting of machinery see Section 3-17.)

Portable equipment, such as test stands, stanchions, jacks, etc. which constitute an obstruction hazard, shall be painted No. 14 Brilliant Yellow. Horizontal surfaces, steps and platforms, subject to wear, may be No. 20 Medium Gray (Federal 16187). (See also Coast Guard Safety Color Code, Section 3-16).

### (Q) FLOORS

Wood floors remaining in a natural finish shall be sealed and waxed. Painted floors shall normally be No. 19 Light Gray. Where maintenance is difficult, such as in shops, No. 20 Medium Gray may be used as an alternate. Painted floors of galleys, heads, furnace rooms, generator rooms and locker rooms shall be No. 26 Tile Red. Concrete floors shall be left unpainted unless required to correct unsightly appearance.



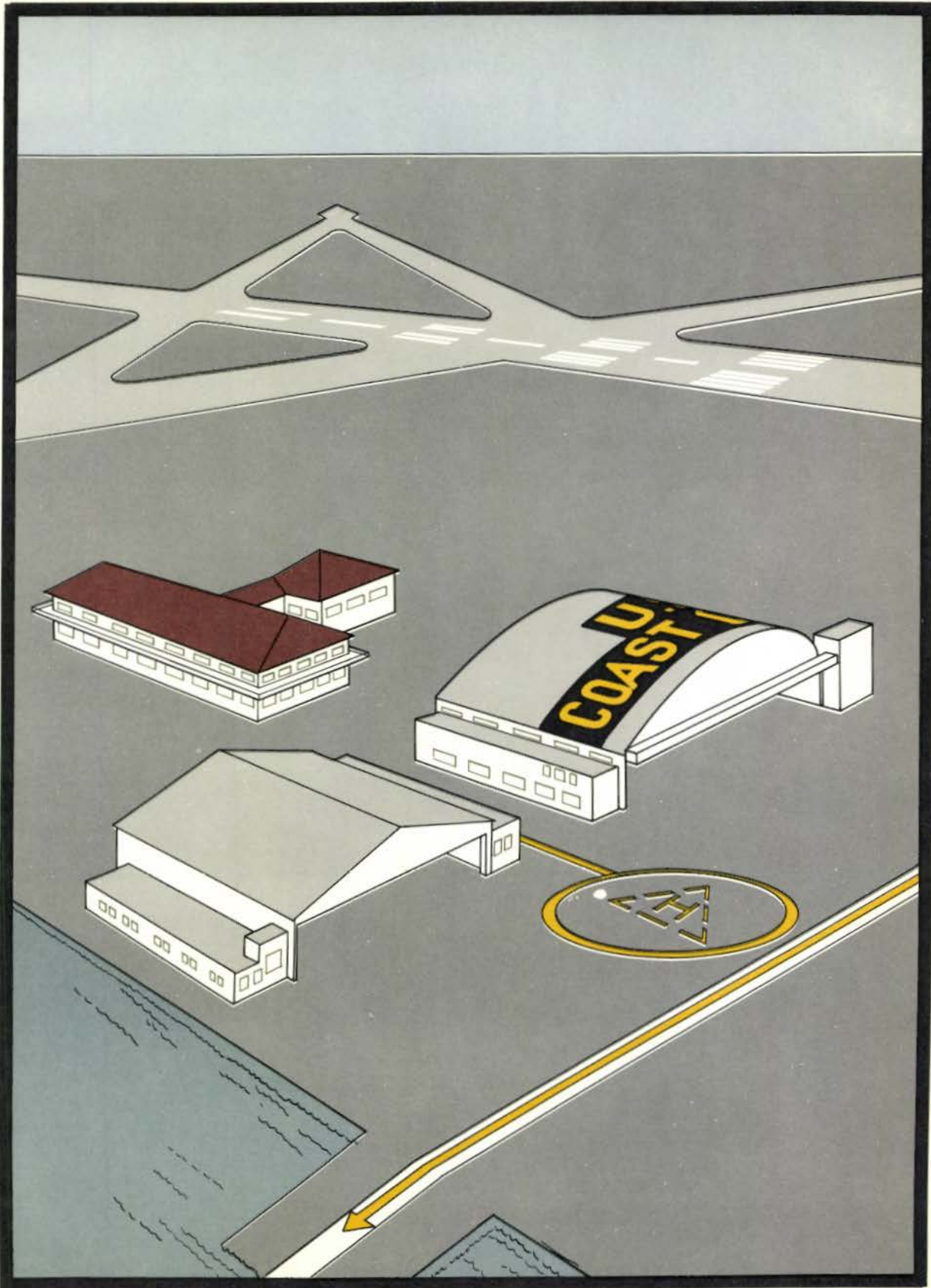



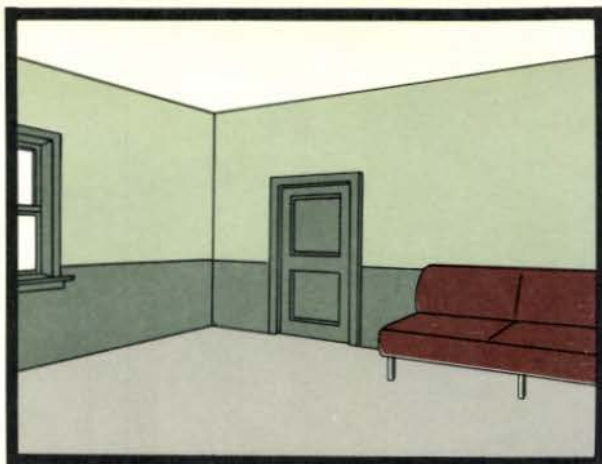

A good recreation room may be planned with Principle O, No. 1 Light Green walls and No. 2 Medium Green trim.

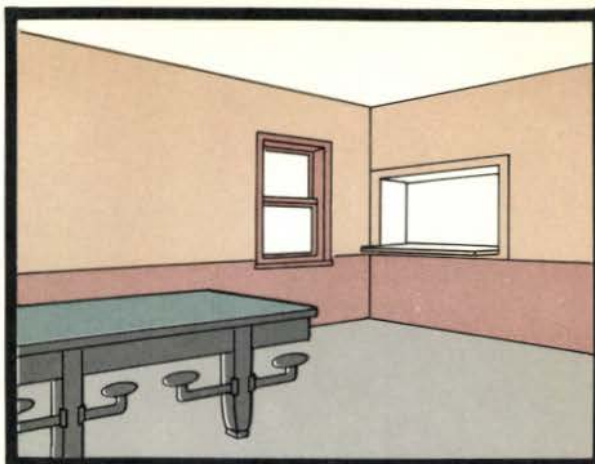

A green recreation room is complemented with mess in Principle M, No. 25 Beach Sand and No. 7 Coral.

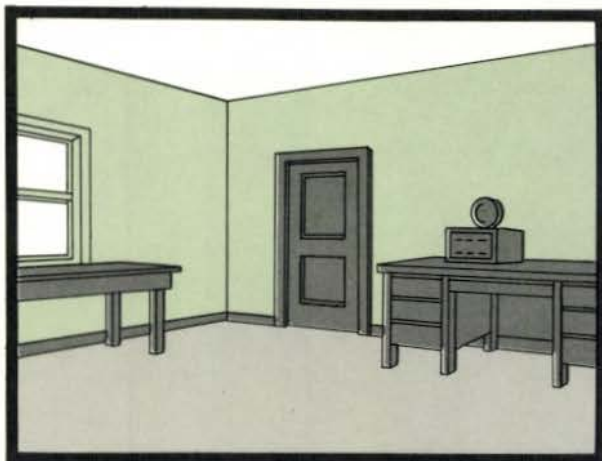

Operations offices are desirable in Principle A, No. 1 Light Green, but also may use Principle B, No. 9 Pearl Gray.

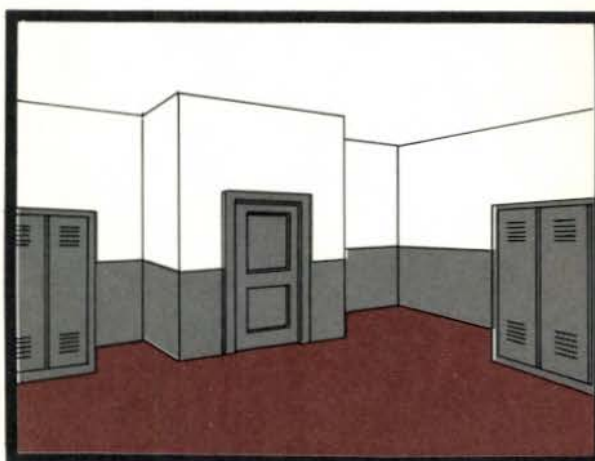

Locker rooms and laundries shall be Principle R, white with No. 19 Light Gray trim. Floors No. 26 Tile Red.

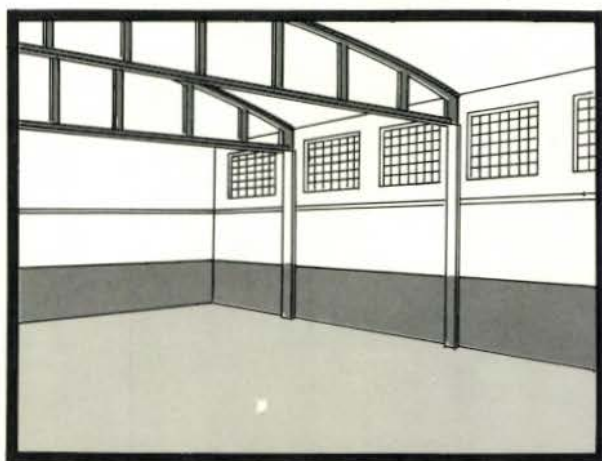

A white hangar with No. 19 Light Gray dado, trim and steel work, Principle R, will be efficient in light reflection.

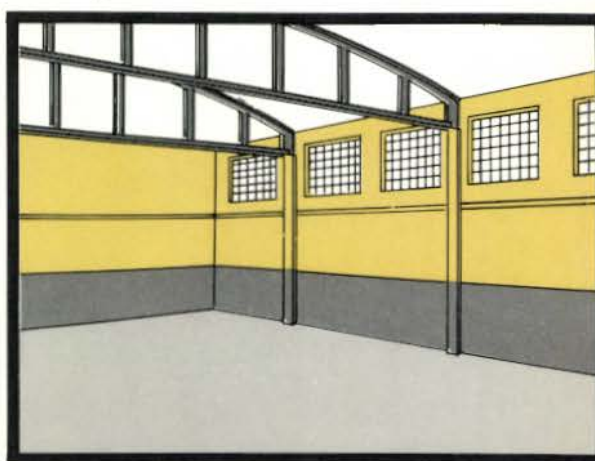

Principle P, No. 4 Soft Yellow with No. 19 Light Gray dado and trim is good for hangars where climate may be cool.



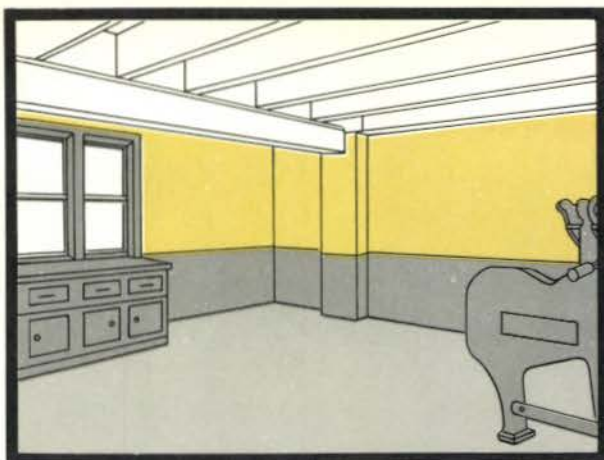

Machine shops may use Principle P, No. 4 Soft Yellow upper walls, No. 19 Light Gray dado, trim and window sash.

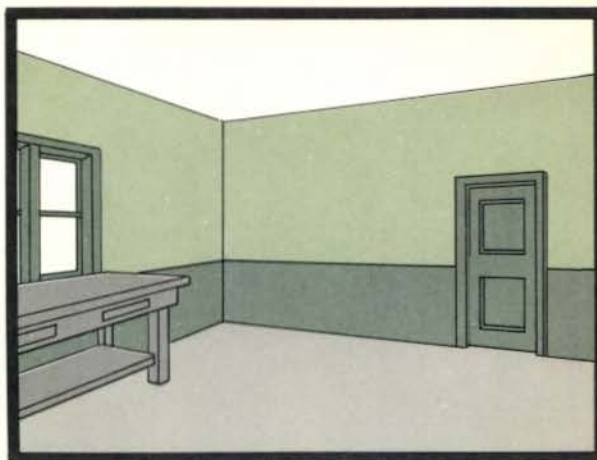

Electronic and electrical shops may use Principle O, No. 1 Light Green walls and No. 2 Medium Green trim.

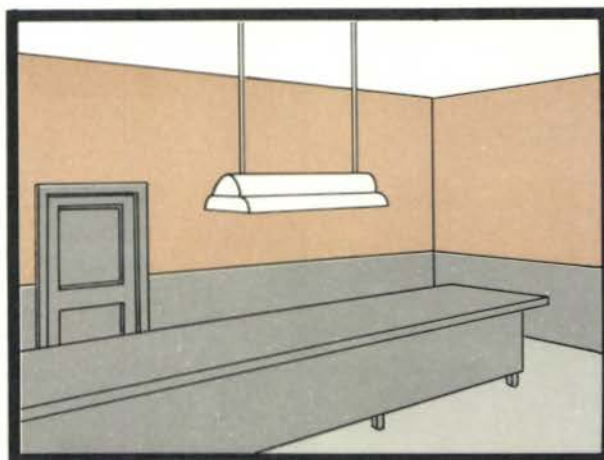

Shops in cold regions may have Principle C, No. 25 Beach Sand with No. 19 Light Gray trim and dado.

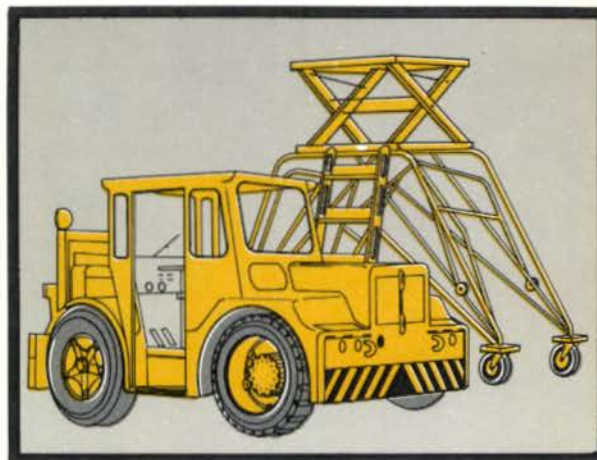

Test stands, ground maintenance equipment, mules and the like should be No. 14 Brilliant Yellow.

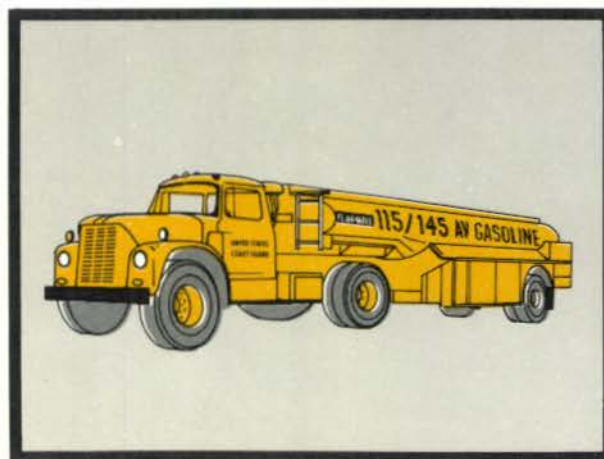

Aircraft refuelers, mules, tractors, transporters used on air fields shall be No. 14 Brilliant Yellow.

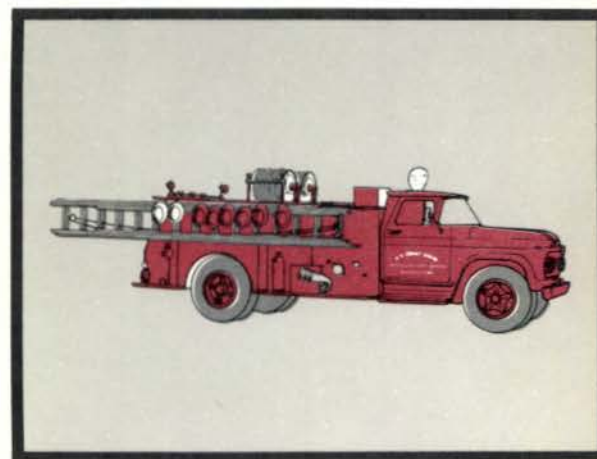

Fire trucks, rescue and crash trucks shall be No. 13 Fire Red for proper identification.



## SECTION 3-8, COLORS FOR ADMINISTRATIVE FACILITIES

These instructions are applicable to the following facilities:

Area Offices	Marine Inspection Offices
District Offices	Academy
Group Offices	Training Station
Captain of the Port Offices	Receiving Centers
Recruiting Stations	

### 3-8-1, EXTERIOR COLORS FOR ADMINISTRATIVE FACILITIES

The maintenance of the Coast Guard's administrative facilities is generally the responsibility of either the General Services Administration or private owners. Only where the responsibility for maintenance rests with the Coast Guard are the following instructions applicable.

#### (A) WOOD, METAL AND PAINTED MASONRY BUILDINGS

See Article 3-4-1(A).

#### (B) RED BRICK BUILDINGS

See Article 3-4-1(B).

#### (C) UNPAINTED STONE AND MASONRY BUILDINGS

See Article 3-4-1(C).

#### (D) ROOFS AND FOUNDATIONS

See Article 3-4-1(E).

#### (E) MISCELLANEOUS STRUCTURES

See Article 3-4-1(F).

#### (F) TANKS

See Article 3-4-1(G).

#### (G) HAZARDS TO AIR NAVIGATION

See Article 3-7-1(G).

#### (H) TRAFFIC AREAS

See Article 3-7-1(J).

### (I) OUTDOOR MACHINERY AND EQUIPMENT

Winches, cranes and other outdoor machinery and equipment shall be painted No. 20 Medium Gray (Federal 16187). See Section 3-11.

### 3-8-2, INTERIOR COLORS FOR ADMINISTRATIVE FACILITIES

#### (A) CEILINGS

Ceilings are to be white throughout with the exception of spaces where dim lighting is desirable to read illuminated dials, scopes, etc. as in CIC training rooms. In such cases extend the wall color over the ceiling.

#### (B) TRIM

See Article 3-7-2(B).

#### (C) BARRACKS AND SLEEPING QUARTERS

See Article 3-7-2(C).

#### (D) WARDROOMS, RECEPTION ROOMS AND WOMEN'S REST ROOMS

To provide for wide latitude in functional and decorative effect, wardrooms, reception rooms and women's rest rooms are allowed a maximum number of color schemes. Principle A (No. 1 Light Green), Principle B (No. 9 Pearl Gray) and Principle E (No. 23 Turquoise) impart a cool and fresh atmosphere. These colors are best in warm or moderate climates. Principle C (No. 25 Beach

### 3-8-2

Sand) and Principle D (No. 4 Soft Yellow) are warm in tone and will help compensate for low average temperatures. Principle G (No. 2 Medium Green) and Principle H (No. 7 Coral) are deeper in tone and cheerful to the eye. Principle F (No. 6 Ivory) is a general purpose color scheme suitable in all environments. Principle J (No. 9 Pearl Gray with No. 23 Turquoise end wall), Principle K (No. 9 Pearl Gray with No. 4 Soft Yellow end wall) and Principle L (No. 9 Pearl Gray with No. 7 Coral end wall), have a unique decorative effect. In each instance the colored wall should be at the end or far side of the room and never on a wall with windows.

#### (E) OFFICES AND OPERATIONS ROOMS

Offices and operations rooms may take a variety of color effects: Principle A (No. 1 Light Green) or Principle B (No. 9 Pearl Gray) for south and west exposures; Principle C (No. 25 Beach Sand) or Principle F (No. 6 Ivory) for north and east exposures. In large general offices Principle D (No. 4 Soft Yellow) may be used satisfactorily. For offices having heavy traffic or occupancy, Principle O (No. 1 Light Green with No. 2 Medium Green dado and trim) is best.

#### (F) RADIO ROOMS AND COMMUNICATION CENTERS

See Article 3-7-2(F).

#### (G) MESS HALLS, CAFETERIAS AND DINING ROOMS

See Article 3-7-2(G).

#### (H) RECREATION ROOMS, LOUNGES

See Article 3-7-2(H).

#### (I) SANITARY SPACES

See Article 3-7-2(I).

#### (J) UTILITY SPACES AND STORAGE SPACES

See Article 3-7-2(J).

#### (K) STAIRWAYS, CORRIDORS AND PASSAGEWAYS

See Article 3-7-2(K).

#### (L) DISPENSARIES, INFIRMARIES AND SICK BAYS

See Article 3-7-2(L).

#### (M) CLASSROOMS, DRAFTING ROOMS AND LABORATORIES

For classrooms, training rooms, drafting rooms and laboratories Principle A (No. 1 Light Green), Principle B (No. 9 Pearl Gray) or Principle C (No. 25 Beach Sand) shall be used. However, where personnel are seated to face in one direction, the end wall treatment serves a wholly practical and functional purpose and may be used. Two effects are suggested, Principle J (No. 9 Pearl Gray with No. 23 Turquoise end wall) and Principle K (No. 9 Pearl Gray with No. 4 Soft Yellow end wall). The green end wall is recommended for areas having good light; yellow may be specified where a brighter and more luminous effect is desired. Also suitable is Principle L (No. 9 Pearl Gray with No. 7 Coral end wall). In each instance the colored wall should be at the end or far side of the room and never on a wall with windows.

#### (N) EXCHANGES

See Article 3-7-2(M).

#### (O) BARBER SHOPS

Use Principle G (No. 2 Medium Green) or Principle A (No. 1 Light Green) with white trim.

#### (P) GYMNASIUMS

Use Principle P (No. 4 Soft Yellow with No. 19 Light Gray dado and trim) or No. 6 Ivory with No. 19 Light Gray dado and trim. Bleachers shall be No. 19 Light Gray.

#### (Q) LIBRARIES

Use Principle A (No. 1 Light Green) with No. 19 Light Gray for trim and shelving.

#### (R) AUDITORIUMS AND THEATERS

Use Principle M (No. 25 Beach Sand with No. 7 Coral dado and trim) or Principle O (No. 1 Light Green with No. 2 Medium Green dado and trim).



**(S) CHAPELS**

Chapels may use Principle A (No. 1 Light Green), Principle B (No. 9 Pearl Gray), Principle C (No. 25 Beach Sand) or Principle I (white).

**(T) SHOPS**

See Bases and Depots, Articles 3-9-2, (N) to (Q).

**(U) EQUIPMENT AND MACHINERY**

See Article 3-7-2(P).

**(V) FLOORS**

See Article 3-7-2(Q).



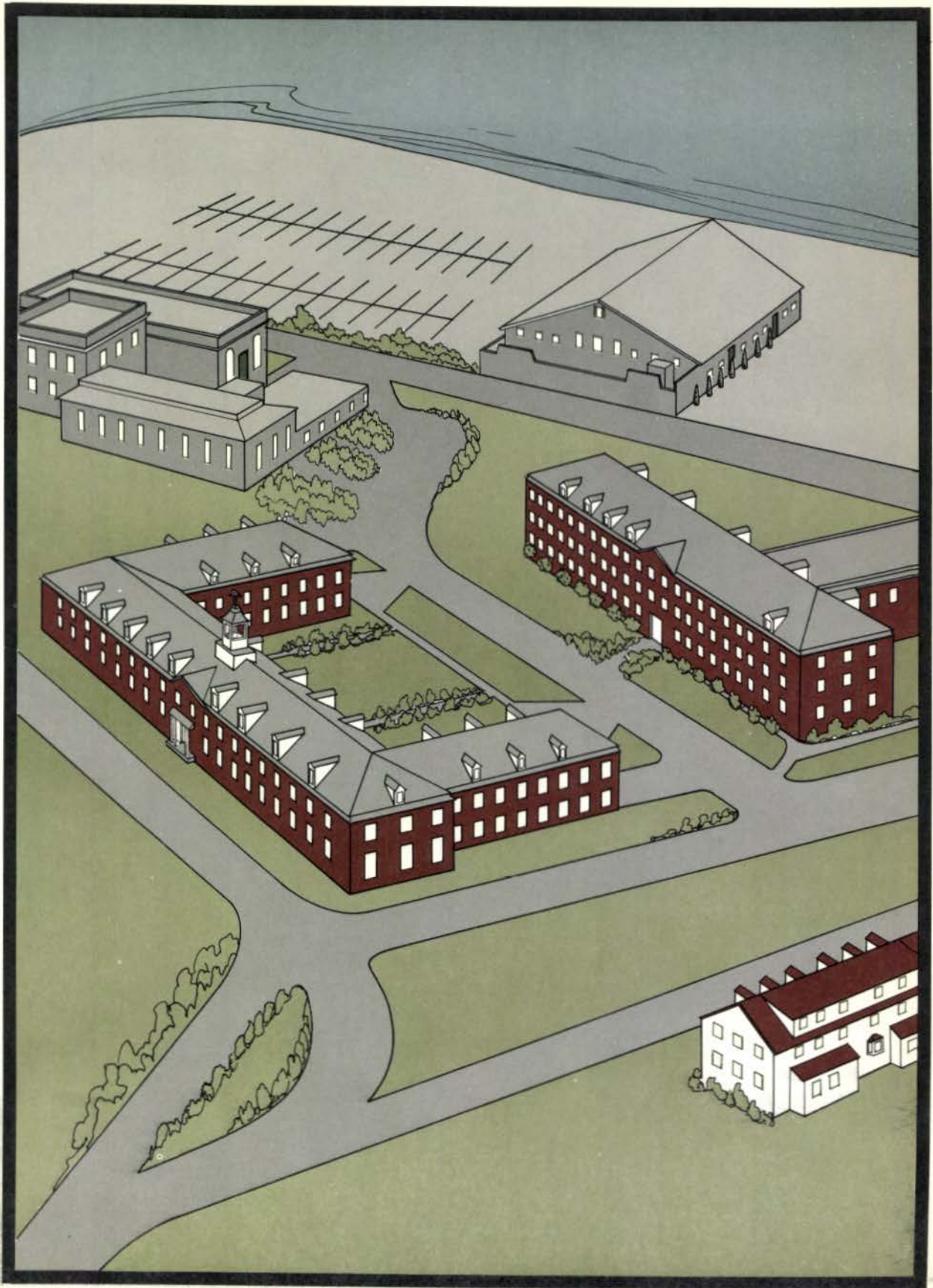





Principle E, using No. 23 Turquoise, makes an ideal parlor or lounge for a cool and restful effect.

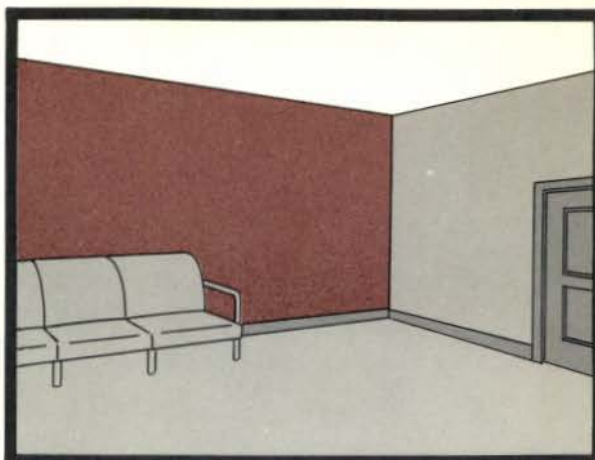

Three walls in No. 9 Pearl Gray, with end wall in No. 7 Coral, Principle L, makes an effective rest room.

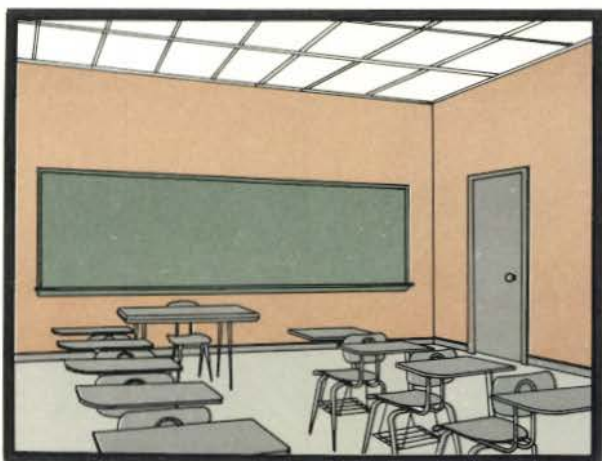

Classrooms may be in a variety of colors. Here is Principle C, No. 25 Beach Sand, having a warm quality.

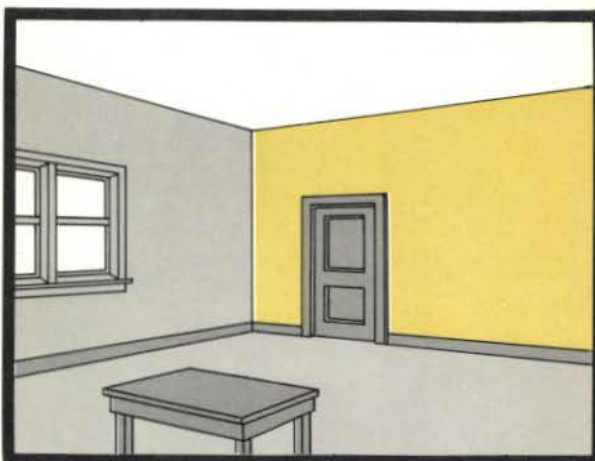

Principle K combines No. 9 Pearl Gray with No. 4 Soft Yellow on end wall. This would enliven a dark room.

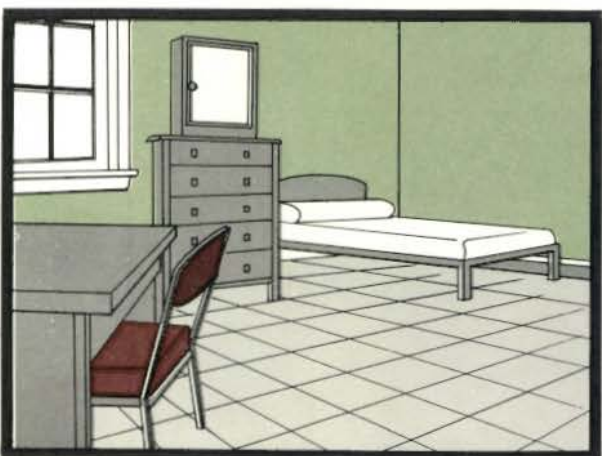

Principle A, No. 1 Light Green, makes an ideal color for sleeping quarters, sick bays and rest rooms.

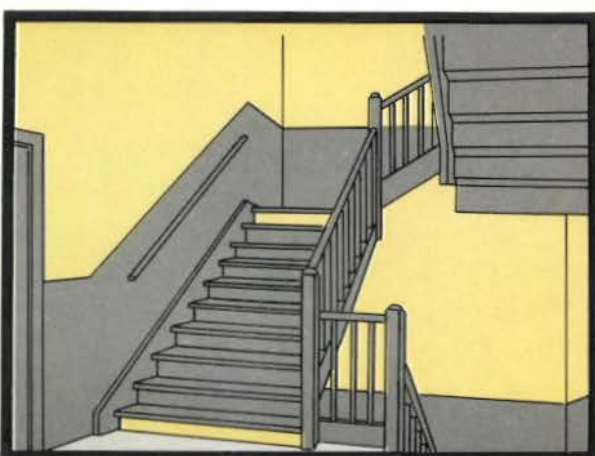

Principle D, No. 4 Soft Yellow with No. 19 Light Gray dado and trim is advised for passageways and stairways.



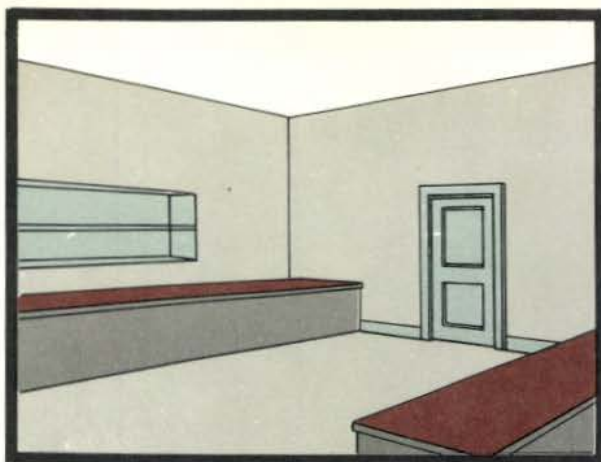

Exchange stores may be specially treated with No. 9 Pearl Gray on walls, No. 23 Turquoise on trim and fixtures.

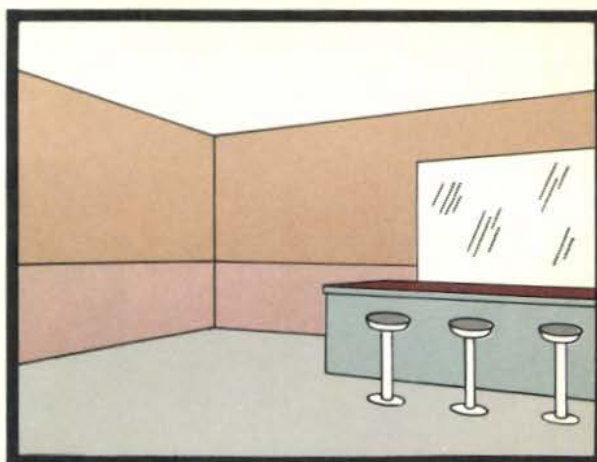

Exchange soda fountains and snack bars may use Principle M, No. 25 Beach Sand walls with No. 7 Coral trim.

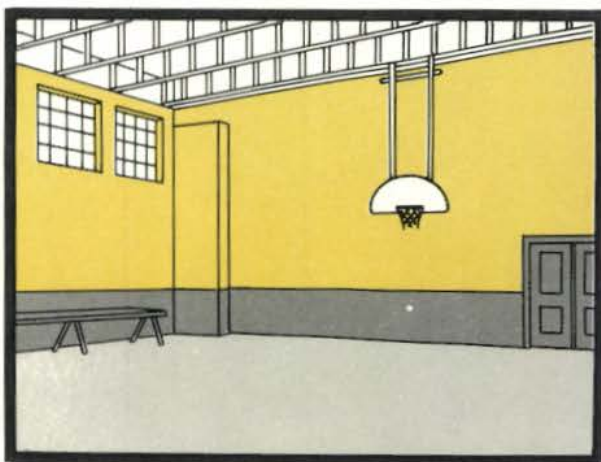

Gymnasiums may use Principle P, No. 19 Light Gray for trim and dado with No. 4 Soft Yellow.



Libraries should have Principle A, No. 1 Light Green for walls with No. 19 Light Gray trim and shelving.



Recreation rooms and lounges in No. 23 Turquoise or No. 7 Coral will be restful to the eyes.

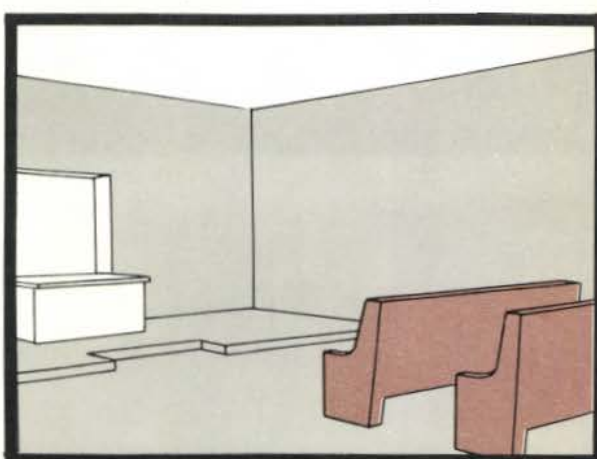

Chapel walls may be No. 1 Light Green, No. 9 Pearl Gray or No. 25 Beach Sand.





## SECTION 3-9, COLORS FOR BASES AND DEPOTS

These instructions are applicable to the following facilities:

Coast Guard Yard    Electronic Repair Shops  
 Moorings    Supply Centers  
 Supply Depots

### 3-9-1, EXTERIOR COLORS FOR BASES AND DEPOTS

#### (A) WOOD, METAL AND PAINTED MASONRY BUILDINGS

Non-industrial Type Buildings—

See Article 3-4-1(A).

Industrial Type Buildings—

Shops, warehouses, garages, galvanized iron sheds, open steel welding sheds and other industrial type buildings shall be painted No. 19 Light Gray. The trim on such structures—doors, door frames, window sash, roof gutters and eaves—shall be No. 12 Spruce Green.

#### (B) RED BRICK BUILDINGS

Non-industrial Type Buildings—

See Article 3-4-1(B).

Industrial Type Buildings—

Trim with No. 12 Spruce Green in the same manner as white is used for non-industrial type buildings.

#### (C) UNPAINTED STONE AND MASONRY BUILDINGS

See Article 3-4-1(C).

#### (D) ROOFS AND FOUNDATIONS

See Article 3-4-1(E).

#### (E) MISCELLANEOUS STRUCTURES AND TANKS

See Articles 3-4-1(F) and 3-4-1(G).

Steel smokestacks shall be No. 19 Light Gray or, if high temperatures are involved, aluminum. Small independent fire houses containing hose carts and extinguishers shall be painted No. 13 Fire Red. This same color

shall be applied to all fire hydrants, hose and sprinkler line stand pipes.

Where tall structures are a hazard to air navigation, refer to Federal Aviation Agency publication "Obstruction Marking and Lighting," obtainable from the Superintendent of Documents, Government Printing Office, Washington, D.C. 20402.

#### (F) FLAMMABLE LIQUIDS STORAGE

Sheds, small buildings and lockers used for the storage of paints, fuels and other flammable liquids shall be painted No. 14 Brilliant Yellow and prominently identified as to contents with large black letters. Larger buildings with flammable stores, however, may be painted in the basic color scheme of the station and prominently identified as to contents by the words: FLAMMABLE LIQUIDS STORAGE in large No. 14 Brilliant Yellow letters.

Large storage tanks (over 1,000 gals. capacity) containing flammable liquids are to be painted No. 12 Spruce Green and shall have the name of the contents painted in large No. 14 Brilliant Yellow letters on the exterior of the tank in a conspicuous location. Smaller containers for flammable liquids or gases, also paint lockers, shall be painted No. 14 Brilliant Yellow overall with the contents conspicuously indicated in large black letters.

Large flammable liquid storage tanks in tropical and semi-tropical areas may be painted aluminum to reduce heat absorption.

#### (G) TRAFFIC AREAS

See Article 3-6-1(I).

Care should be taken to add safety marking with bands of black and No. 14 Brilliant Yellow on curbing, bumpers, the edges of platforms and pits, low beams and any other

### 3-9-2

obstructions which may constitute a hazard. For further details on safety markings see Safety Color Code, Section 3-16.

#### (H) OUTDOOR MACHINERY AND EQUIPMENT

Winches, cranes and other outdoor machinery and equipment shall be painted No. 20 Medium Gray. Barges, drydocks, floating derricks and other floating equipment shall be No. 20 Medium Gray with superstructure No. 19 Light Gray. For further data see Shore Equipment, Section 3-11.

### 3-9-2, INTERIOR COLORS FOR BASES AND DEPOTS

#### (A) CEILINGS

Ceilings and overheads in industrial areas shall be white. This includes wood and concrete beams, trusses and sash in monitors. Steel beams and trusses, however, may be No. 19 Light Gray. Wall colors shall extend to a line level with the bottoms of roof beams or trusses.

#### (B) TRIM

Trim including baseboards, window frames, window and door sash, doors, stair balustrades and stringers shall be either white or No. 19 Light Gray. Fixed equipment against walls, such as cabinets, shall be in either the wall or trim color. White is preferred for trim in the living spaces while No. 19 Light Gray is preferred for industrial buildings. The trim on industrial buildings shall be used over dados, doors, door frames, window sash and radiators in accordance with the color principle applied.

#### (C) BARRACKS AND SLEEPING QUARTERS

See Article 3-7-2(C).

#### (D) WARDROOMS, RECEPTION ROOMS, AND WOMEN'S REST ROOMS

See Article 3-8-2(D).

#### (E) OFFICES

See Article 3-8-2(E).

#### (F) MESS HALLS, CAFETERIAS AND DINING ROOMS

See Article 3-7-2(G).

#### (G) RECREATION ROOMS, LOUNGES

See Article 3-7-2(H).

#### (H) SANITARY SPACES

See Article 3-7-2(I).

#### (I) UTILITY AND STORAGE SPACES

Basements, furnace rooms, battery rooms, generator rooms, emergency power rooms, power plants, boiler rooms, compressor rooms, laundries, stock rooms, spare parts store-rooms, closets and locker rooms, shall be painted Principle I (white) or Principle R (white with No. 19 Light Gray dado and trim). Boiler fronts shall be No. 19 Light Gray, No. 20 Medium Gray or aluminum. Insulated boiler jackets shall be white. Oil burners shall be No. 20 Medium Gray.

#### (J) STAIRWAYS, CORRIDORS AND PASSAGEWAYS

See Article 3-7-2(K).

#### (K) DISPENSARIES, INFIRMARIES AND SICK BAYS

See Article 3-7-2(L).

#### (L) EXCHANGES

See Article 3-7-2(M).

#### (M) BARBER SHOPS

See Article 3-8-2(O).

#### (N) SHOPS—FINE WORK

In shops where personnel are concentrated or where difficult visual tasks are performed, Principle O (No. 1 Light Green walls, No. 2 Medium Green dado and trim) shall be used. This would include small workshops and machine shops, electrical shops, electronic repair shops, camera repair shops, laboratories, testing areas, or wherever problems of visibility are present and where the use of a soft green will reduce wall glare.

**(O) SHOPS—AVERAGE WORK**

Principle O (No. 1 Light Green walls, No. 2 Medium Green dado and trim) may also be used in larger shops having fairly heavy occupancy. For very large interiors, however, Principle P shall be used (No. 4 Soft Yellow walls, No. 19 Light Gray dado and trim). This includes large machine shops, engine repair shops, carpenter shops and mills, boat repair shops, large erection shops, rigging shops, garages.

**(P) SHOPS—HEAVY WORK**

In heavy metal work shops, forge shops and plating shops, Principle R shall be used (white walls, No. 19 Light Gray dado and trim). Where trouble is encountered with steelwork because of fumes, aluminum heat-resisting paint may be substituted as an alternate for No. 19 Light Gray. Ventilating ducts and hoods should be either No. 19 Light Gray or aluminum.

For heat treating, Principle N shall be applied (white walls with No. 23 Turquoise dado and trim). The purpose here is to introduce a cool color to offer psychological compensation for high temperatures. Heat treating devices, hoods, ducts, may be aluminum heat-resisting paint if exposure to high temperatures is involved. Otherwise, No. 19 Light Gray should be used. Tanks and equipment should be No. 20 Medium Gray.

**(Q) SHOPS—SPECIAL WORK**

If low levels of illumination are necessary for the viewing of instruments, dials or scopes, such as in some electronic shops, No. 2 Medium Green (Principle G) shall be used uniformly over walls and ceilings to reduce reflections. In photographic units and camera departments, Principle Q may be used (No. 9 Pearl Gray walls with No. 19 Light Gray dado and trim). Dark rooms shall follow Principle P (No. 4 Soft Yellow walls, No. 19 Light Gray dado and trim). Principle O (No.

1 Light Green walls, No. 2 Medium Green dado and trim) may be used as an alternate. Tanks in dark rooms shall be No. 20 Medium Gray.

**(R) EQUIPMENT AND MACHINERY**

No. 20 Medium Gray (Federal 16187) shall be used for miscellaneous areas in industrial units, such as catwalks, ladders, metal walkways. Overhead cranes shall be No. 19 Light Gray. The exterior of the crane cab shall be No. 14 Brilliant Yellow to aid location. No. 14 Brilliant Yellow shall also be applied to crane hooks and pulleys. Use No. 19 Light Gray or No. 20 Medium Gray for heating units, blowers, ducts, conveying equipment, tanks. Smaller hoists and jib cranes shall be No. 20 Medium Gray. The ends of crane beams shall be marked with bands of No. 14 Brilliant Yellow and black.

For equipment where cleanliness is important or where maintenance is not difficult, such as portable testing apparatus, desks, stools, filing cabinets, electrical equipment, fine machine tools, etc. use No. 30 Equipment Gray. For equipment where rougher work is involved, maintenance is difficult and cleanliness is not essential, such as lathes, drill presses, shapers, milling machines, tool grinders, power saws, tool racks and bins, use No. 20 Medium Gray.

Portable equipment which constitutes an obstruction hazard such as test stands, stanchions and jacks shall be painted No. 14 Brilliant Yellow. Horizontal surfaces, steps and platforms subject to wear may be No. 20 Medium Gray. (See Safety Color Code, Section 3-16).

For the finishing and highlighting of machinery, see Section 3-17, Machinery Colors.

**(S) FLOORS**

See Article 3-5-2(L).









In shops and laboratories, use Principle O, No. 1 Light Green walls and No. 2 Medium Green trim and dado.

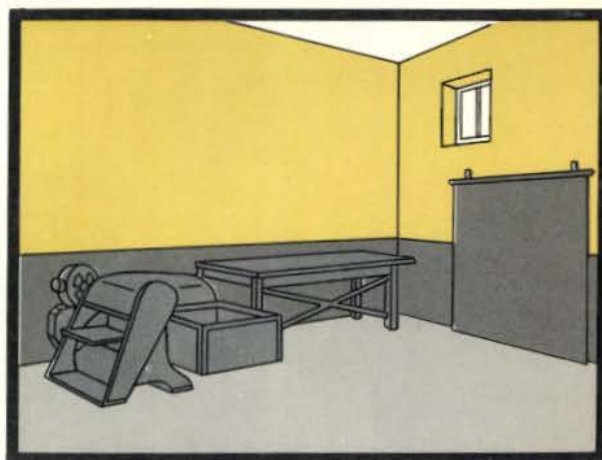

Large shops should use Principle P, No. 4 Soft Yellow walls with No. 19 Light Gray for trim and dado.

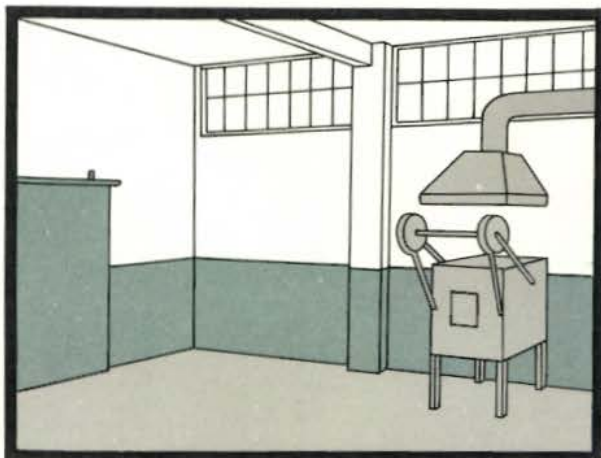

In heat treating, Principle N, white walls should be combined with No. 23 Turquoise on dado and trim.

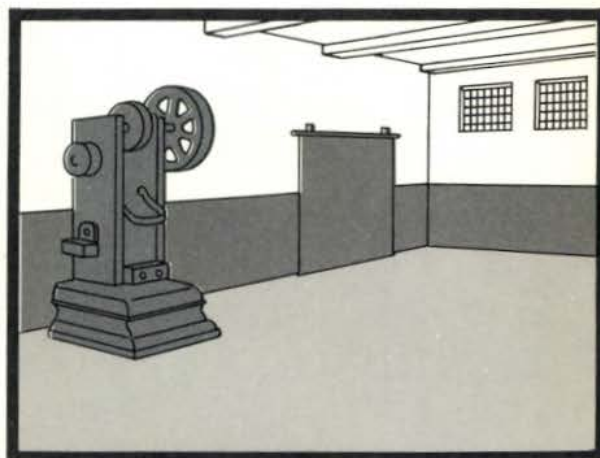

Metal working shops, if painted, should be Principle R, white with No. 19 Light Gray on trim.

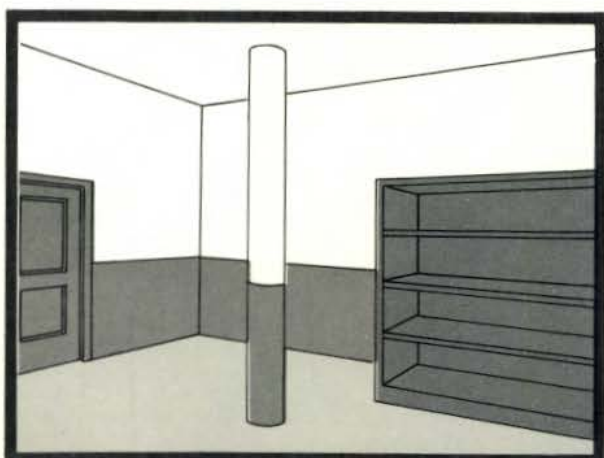

Stock rooms, paint shops, may use Principle R, white walls with No. 19 Light Gray for dado and trim.

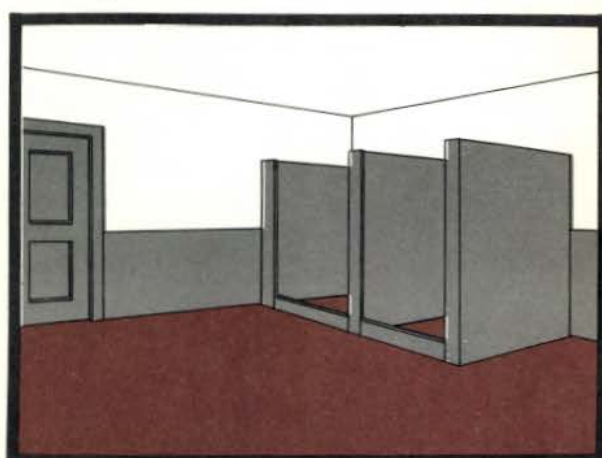

Personnel facilities, such as heads and shower rooms, should be Principle I (white). Floors No. 26 Tile Red.





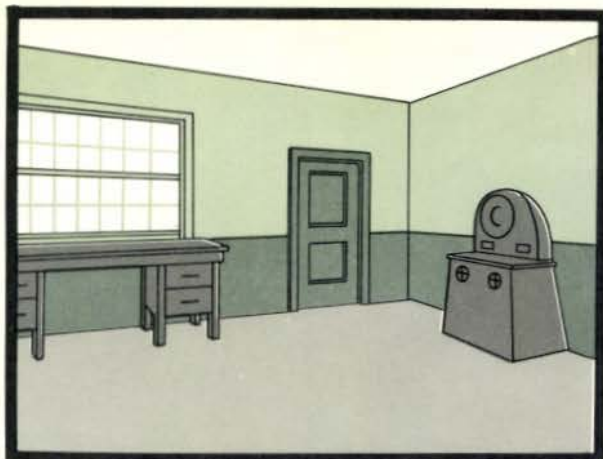

Laboratories and materials testing use Principle O, No. 1 Light Green walls, No. 2 Medium Green trim and dado.

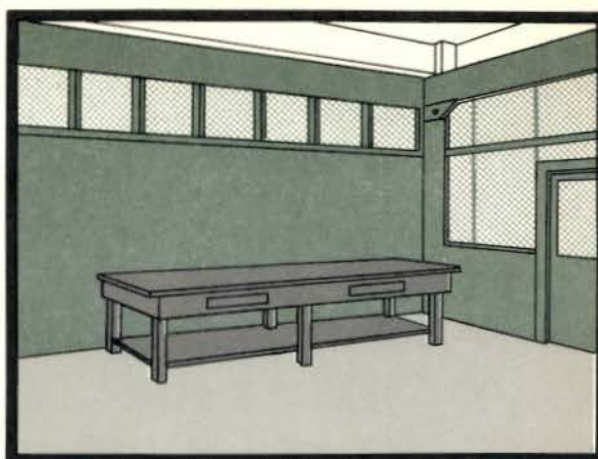

Where dim light is required Principle G, No. 2 Medium Green may be used uniformly over walls and trim.

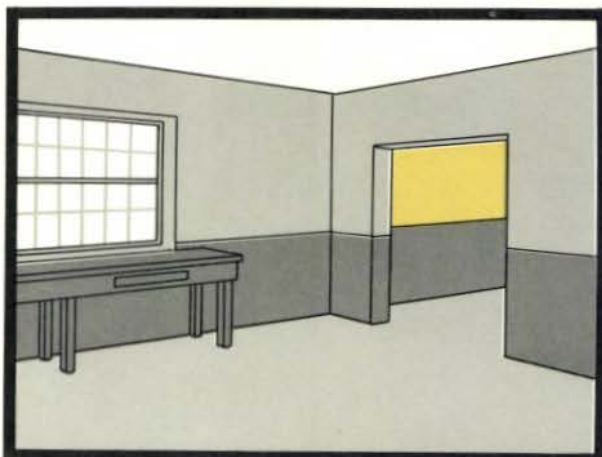

Photographic units may use Principle Q, No. 9 Pearl Gray walls with No. 19 Light Gray trim and dado.

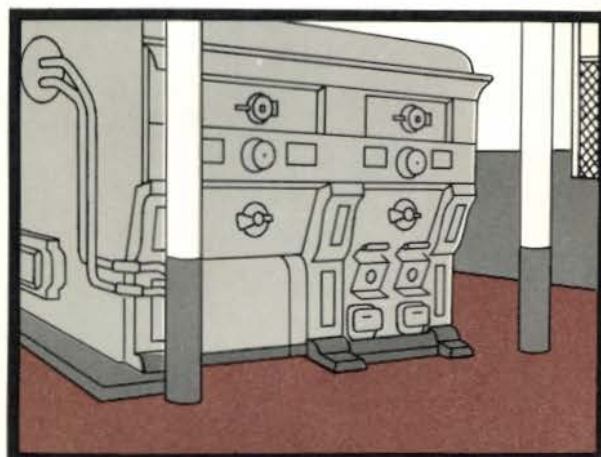

Boiler and engine rooms should be Principle R, white with No. 19 Light Gray trim and dado, No. 26 Tile Red floors.

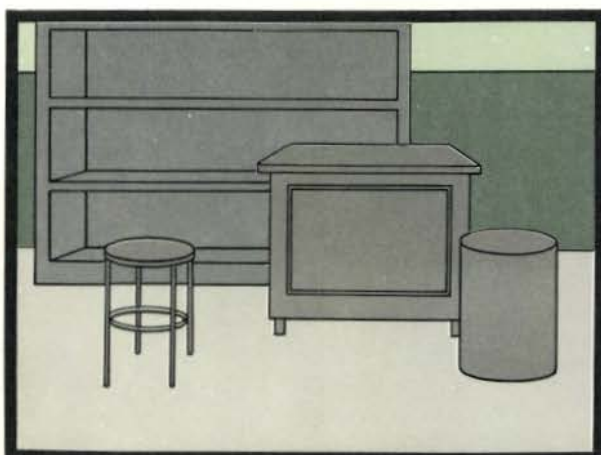

Equipment shall be No. 30 Equipment Gray or No. 20 Medium Gray, depending on use.

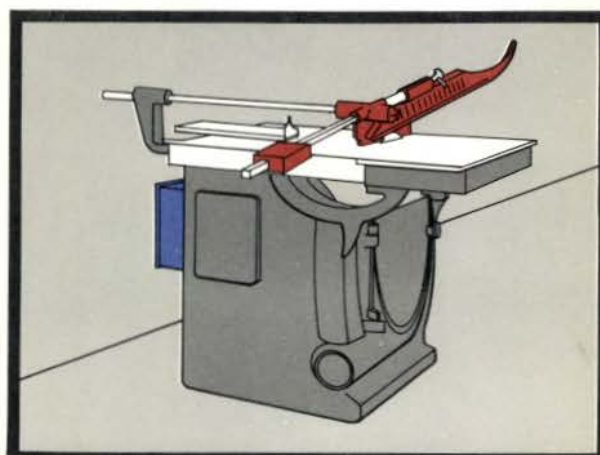

Machinery should be well maintained and guarded. Hazards should be color coded for safety.



## SECTION 3-10, MISCELLANEOUS FURNISHINGS FOR SHORE ESTABLISHMENTS

The following general suggestions shall be considered in the use of various furnishings at Coast Guard units. Simplicity and standardization are desired. Except for family quarters, decorative features should follow those commonly seen in office buildings.

### 3-10-1, LINOLEUM AND COMPOSITION FLOORS

Where linoleum, asphalt tile, vinyl asbestos tile or other composition flooring is to be purchased, the deep colors formerly used, such as black, dark green, and dark brown shall be avoided. Such colors waste light, show minor dirt marks, and do not invite orderly maintenance. The preferred colors—all of medium or light tones—are marbled gray, marbled green, marbled tan and, for some purposes marbled red. These finishes, being fairly neutral, will harmonize with practically any wall color. The irregular pattern of the marbled materials in the light rather than the dark tones reduces maintenance by concealing normal foot marks and minor surface damage.

In family quarters it is desired, particularly, to get away from dull, dark floor coverings. When replacement coverings are necessary, lighter and more cheerful colors should be chosen. In general, vinyl, vinyl asbestos, or asphalt tiling will give better service than the conventional linoleum types.

Where this Manual refers to No. 26 Tile Red for floors and where a linoleum or composition flooring is to be used, the covering need not be plain, but should match No. 26 Tile Red as nearly as practical.

### 3-10-2, CARPETING

In carpeting, hard twist weaves are preferred in plain or heather (varicolored) pile. For offices and similar areas, the recommended colors are medium gray, green, or tan. Tufted carpeting having nylon, acrylic or olefin fiber

yarns will wear exceedingly well and be easy to clean.

In the case of family quarters, rugs and carpeting with multicolored designs are suggested. Since family quarters should be as pleasant as possible, the interior of the rooms should be light and cheerful.

### 3-10-3, COUNTER AND DESK TOPS

Linoleum counters and desk tops are now being manufactured to approximate the tone of No. 30 Equipment Gray. This is a very excellent color for such furnishings as desks, tables, benches. Its high light reflection and clean appearance are both desirable. For food service, however, plastic laminates or similar hard surfaced materials are recommended. These materials are easy to clean and resist burns and stains. Off-white, blue or green in solid, linen or marbled patterns may be specified as an alternate choice for gray in mess halls; blue coverings should not be used elsewhere.

### 3-10-4, UPHOLSTERING MATERIALS

There are three basic types of materials commonly used for upholstery. The first are woven or pile, natural fiber materials, such as cotton and wool. These are practical and economical. Because of their soft texture they are comfortable and suitable for all climates. These fabrics tend to "breathe" and will not prove slippery or sticky under normal use. To their disadvantage, they may fade or be difficult to clean. They may be damaged by water or burns.

Second are sheet materials, such as leather and vinyl. Leather is not recommended because it tends to crack and deteriorate with age, and to develop a mold in a moist climate. Vinyl upholstery materials are very reasonable in cost. They have a more or less impervious surface and are easy to clean. However, because they fail to absorb moisture they may prove slippery and may be uncomfortable in a

### 3-10-6

warm climate by "sticking" to the skin or clothing. Vinyl upholstery materials are now available which have minute perforations and therefore tend to "breathe." These may be considered. Certain "breathable" vinyls, such as Coair, are also on the market and may be investigated.

Vinyl upholstery fabrics with cotton fabric backs may develop mildew. These can be effectively treated with a mildewcide before the vinyl is installed. Light weight vinyls made especially for marine use, with resistance to fading, mildew and salt water may be applicable in some instances.

Third are woven filament materials, such as Saran, Dacron, Nylon, and Velon. These are made of synthetic fibers and may be high in cost. They are easy to clean and will tend to "breathe," and wear almost indefinitely.

In selecting colors for upholstery, Coast Guard standards shall be matched wherever possible. Gray is a good color, also maroon, green, blue and tan or beige. Pale shades and bright colors should be avoided.

#### 3-10-5, DRAPERY MATERIALS

Drapery materials shall be simple and lacking

in ornamentation or design. Natural tones, beige, pale gray, will give an interior an attractive appearance and will serve a functional purpose by avoiding distractions and unfavorable contrast with adjacent walls. Soft tones of green, tan, rose, and blue are similarly good. For the most part, sharp colors such as brilliant red and yellow shall not be considered. So-called interior decoration should be set aside for a simpler and more direct approach to color that suggests efficiency rather than mere ornamentation. This will assure a suitable and appropriate setting.

Cotton and wool drapery materials can be treated for fire-resistance at small extra cost. Also, cotton and wool upholstery and drapery fabrics can be made to resist dirt, moisture and stains if they are treated with a product such as Scotchgard. The extra cost is reasonable.

#### 3-10-6, WINDOW SHADES

Black or dark green shades are to be avoided unless these colors are necessary for blackout or other purposes. Light colored shades will brighten up a room and serve the original purpose as well as the dark shades.

## SECTION 3-11, COLORS FOR SHORE EQUIPMENT

Recommended colors for outdoor and indoor equipment are given throughout this Manual. To supplement these recommendations, here is further data regarding miscellaneous equipment found particularly at large Bases.

### 3-11-1, CRANES AND SHIPWAYS

Tall dry dock cranes, Gantry cranes, crawler cranes, hammerhead cranes and steel shipways shall be painted No. 12 Spruce Green to tie in with the same standard recommended for tall structures such as towers located at Coast Guard units. For purposes of safety, however, the ends of crane beams shall be painted No. 14 Brilliant Yellow (over a space at least 6 ft. from the top). Yellows shall also be used on crane pulleys and hooks. Bands of No. 14 Brilliant Yellow and black shall be applied conspicuously at ground level on guards over wheels so that movement of cranes will be fully noted by personnel.

### 3-11-2, DRYDOCKS

Floating drydocks shall be painted black, including railings and ladders. Any unguarded platform or dock edges, and any stumbling or obstruction hazards, shall be finished in No. 14 Brilliant Yellow. Large valves controlling pump water flooding and discharge shall have the following symbolism applied: No. 13 Fire Red for the flooding valve; No. 16 Bright Green for the discharge valve; No. 14 Brilliant Yellow for the emergency gate which connects tanks.

### 3-11-3, FLOATING EQUIPMENT

Floating derricks and dredges shall be painted No. 20 Medium Gray. (As traditional aboard ship, wood spars may be painted No. 24 Spar.) The sheds thereon may be No. 19 Light Gray with No. 12 Spruce Green Trim or they may be white with green trim as specified for

Coast Guard buildings and dwellings. Barges accompanying black-hulled vessels shall be painted in the color scheme for black-hulled vessels.

### 3-11-4, MOBILE LAND EQUIPMENT

Mobile equipment, such as locomotives, railway cranes, buoy cranes, automotive and power cranes, road rollers, shall be No. 20 Medium Gray. Safety markings in No. 14 Brilliant Yellow (or black and yellow) shall be applied to crane ends, pulleys, hooks, bumper plates, handrailings and grips. Small mobile equipment, shop mules, lift trucks, boat cradles and the like which might constitute a bumping or tripping hazard should be No. 14 Brilliant Yellow throughout. For further information on vehicles see Section 3-12, Vehicle Colors.

### 3-11-5, DOCK EQUIPMENT

Miscellaneous dock equipment shall be No. 20 Medium Gray, such as winches, engines, pumps, compressors. Welding generator and compressor units shall be No. 20 Medium Gray. However, electric monitors and control boxes, including the control handles, shall be No. 29 Bright Blue to agree with the Safety Color Code.

Trash scoops shall be No. 20 Medium Gray. Tanks for water shall be white. Other tanks—fuel, compressed air, etc.—shall be No. 12 Spruce Green and shall be lettered as to contents with No. 14 Brilliant Yellow. Portable or small sized flammable liquid tanks and containers shall be painted No. 14 Brilliant Yellow throughout, with contents indicated with lettering in black.

Bollards and cleats on docks shall be black. However, if they constitute a serious tripping hazard, as on the edge of a pier, they may be painted No. 14 Brilliant Yellow.



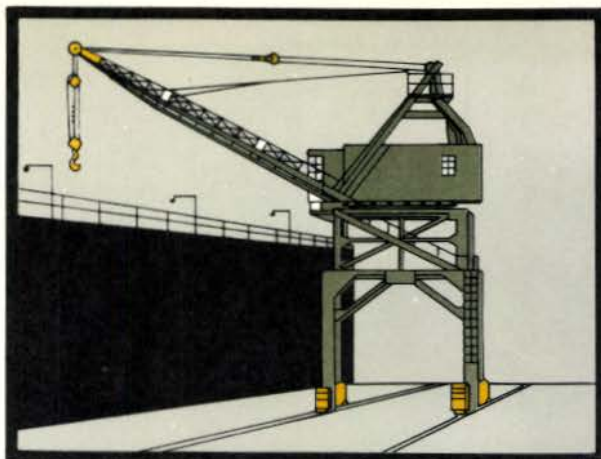

Cranes and shipway structures shall be No. 12 Spruce Green with safety marking in No. 14 Brilliant Yellow.

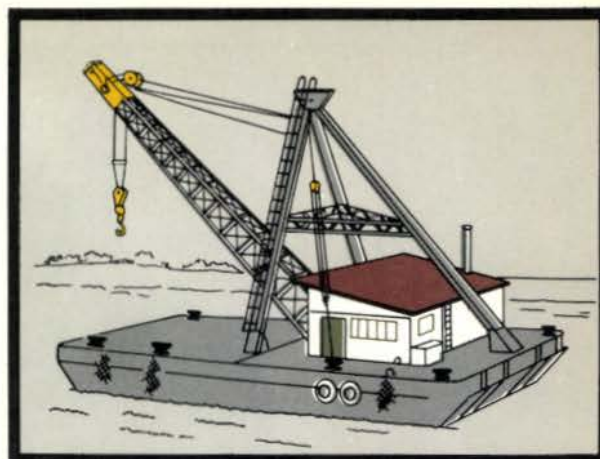

Floating derricks and dredges shall be No. 20 Medium Gray. Sheds may be white or No. 19 Light Gray.

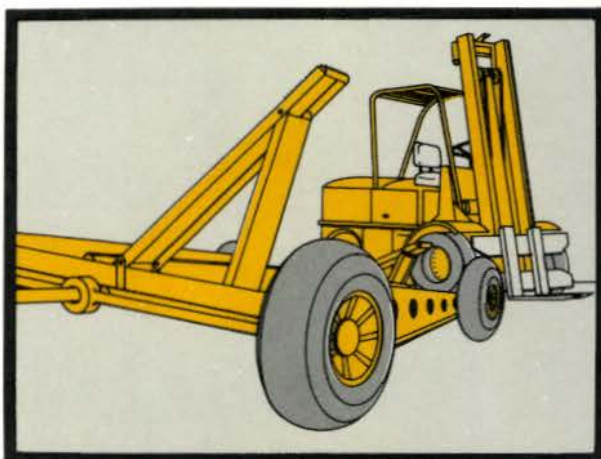

Boat cradles, small mobile equipment, mules, lift trucks, shall be No. 14 Brilliant Yellow throughout.

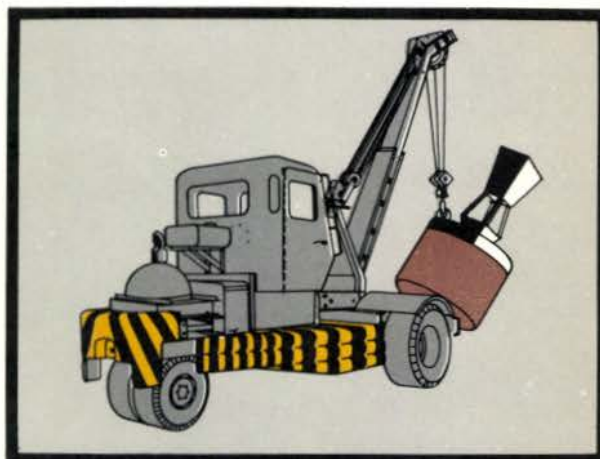

Buoy cranes, automotive and power cranes shall be No. 20 Medium Gray with No. 14 Brilliant Yellow markings.

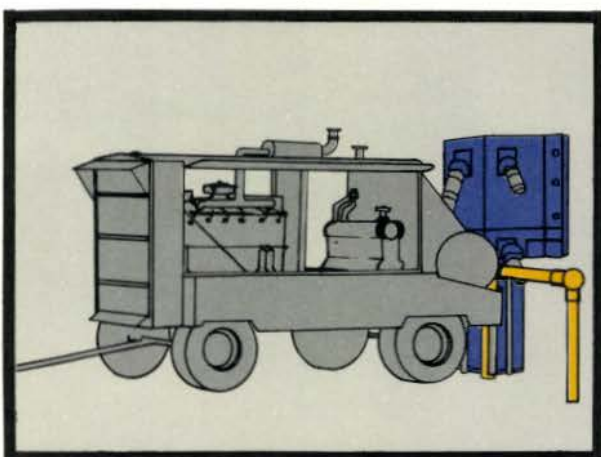

Engines and compressors shall be No. 20 Medium Gray. Electric monitors and control boxes No. 29 Bright Blue.

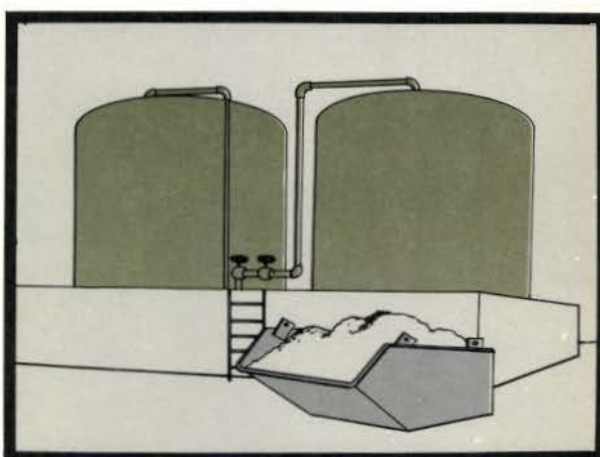

Large steel tanks for fuel oil shall be No. 12 Spruce Green. Use No. 20 Medium Gray for waste containers.





## SECTION 3-12, VEHICLE COLORS AND IDENTIFICATION

### 3-12-1, EXTERIOR COLORS

The following requirements apply only to Coast Guard vehicles and GSA vehicles obtained on a long lease basis. Other vehicles obtained through General Services Administration on a lease basis will follow GSA regulations regarding Coast Guard identification markings and colors. Details on the red and blue stripe with Coast Guard emblem are outlined in the detailed plan for each specific type of vehicle.

Vehicles owned by Coast Guard shall be painted one of five colors: Coast Guard No. 19 Light Gray; No. 14 Brilliant Yellow; No. 13 Fire Red; black; or, in certain prescribed instances, white. When new vehicles are purchased they should be procured in the prescribed color provided this can be done without undue delay in delivery or increase in cost. When this is not possible vehicles shall be procured in the manufacturer's color which most closely matches the prescribed Coast Guard color.

New vehicles, or old vehicles whose paint is in good condition, shall not be repainted to conform to these color requirements. All vehicles shall be painted the prescribed color when routine repainting is accomplished. Exception: GSA leased vehicles.

#### (A) VEHICLES PAINTED NO. 19 LIGHT GRAY

Automobiles, ambulances, trucks, trailers, carryalls, large truck-tractors, station wagons, jeeps and beach carts shall be painted No. 19 Light Gray.

#### (B) VEHICLES PAINTED NO. 14 BRILLIANT YELLOW

Aircraft refueler trucks, scooters, snow plows, snowmobiles, toboggans, tractors, airport mules, fork-lift trucks, line trucks, bulldozers and buoy carriers shall be No. 14 Brilliant Yellow. Exceptions: Snow Vehicles shall be painted International Orange or fluorescent red-orange at the discretion of the commanding officer.

#### (C) VEHICLES PAINTED NO. 13 FIRE RED

Fire trucks, crash and rescue trucks or other vehicles used for these purposes shall be painted No. 13 Fire Red.

#### (D) VEHICLES PAINTED BLACK

Coast Guard sedans assigned for the use of flag officers, district commanders, and commanding officers of HQ units shall be painted black matching Federal Color Std. 17038. Certain automobiles used in investigative work and specifically authorized by the Commandant (O) to display state vehicle plates, in lieu of Government license plates shall be black, except where it is desirable to make the vehicles less conspicuous. Other colors may then be used at the discretion of the District Commander.

#### (E) VEHICLE IDENTIFICATION

The notation "For Official Use Only" must be placed on the sides of each vehicle. If not included in the U.S. Government Shield, it shall be applied in one-inch letters below the shield. Vehicles assigned for the use of flag officers, district commanders, and commanding officers of HQ units shall be exempt from this requirement.

#### Gray Vehicles—

Vehicles painted No. 19 Light Gray shall have identification markings on the center of both front door panels or in an equivalent position relative to the driver's seat if there is no door. The identification shall consist of a 6-in. x 6-in. U.S. Government Shield, the inscription UNITED STATES COAST GUARD and the vehicle license number. The lettering shall be in No. 29 Bright Blue and shall be 2 in. high. The arrangement of the identification markings shall be similar to that illustrated. See Section 3-22, Letters and Numerals, for illustration of lettering to be used.

#### Yellow Vehicles—

Vehicles painted No. 14 Brilliant Yellow shall bear identification markings similar to those painted No. 19 Light Gray. Such letter-

ing shall be black. If these vehicles are used primarily on aircraft landing areas, identification shall be in accordance with current directive of Naval Air Systems Command with appropriate alterations in wording for adoption to Coast Guard use. On those vehicles where space limitations prevent the use of the full inscription it may be abbreviated to U.S.C.G. Aircraft refueler trucks shall have fuel grade and type on tank sides in at least 18-in. lettering.

#### Red Vehicles—

Vehicles painted No. 13 Fire Red shall have identification markings on the center of both front door panels or in an equivalent position relative to the driver's seat if there is no door. The identification shall consist of a 6-in x 6-in. U.S. Government Shield, the inscription U.S. Coast Guard (Name of Unit) and the location of the vehicle. The lettering shall be in gold leaf and shall be 2-in. high. The arrangement of the identification markings shall have the U.S. Government Shield over the lettering.

#### Ambulances—

Ambulances shall in addition to the above identification for gray vehicles carry a 6-in. red cross on a white circular background 9-in. in diameter centered on the forward windows of the litter compartment on each side of the ambulance. The word AMBULANCE in No. 29 Bright Blue letters 3 inches high shall be centered on the rear door panel.

#### Communication Vehicles—

Communication trucks shall, in addition to the above identification for gray vehicles, have air identification markings as follows: An area approximately 3 ft. wide and 11 ft. long on the truck top shall be painted black to provide a background for the truck's radio call letters. The call letters in No. 18 International Orange shall be painted on the black background area in letters 18-in. high by 16-in. wide with a stroke width of 4-in. Refer to Section 3-22, Letters and Numerals for type lettering to be employed.

Communication trucks shall have ground identification markings as follows: A Coast Guard decalcomania 12-in diameter shall be placed on both side panels of the truck body. The words COMMUNICATION TRUCK shall appear over the decalcomania and the district and district location shall appear below the decalcomania. All lettering shall be in No. 29 Bright Blue letters 3-in. high.

Communication Auxiliary Trucks shall have air identification markings similar to Communication Trucks with the markings reduced to scale as necessary. They shall use a Coast Guard decalcomania 12 inches diameter and the lettering on the side panels of the truck shall be 2-in. in height.

Coast Guard decalcomanias are obtainable from Coast Guard Supply Center, Brooklyn, New York.

#### Tank Trucks—

Tank trucks, in addition to the identification markings required of all gray vehicles, shall have the word FLAMMABLE displayed on each side and on the rear of the tank body in No. 14 Brilliant Yellow letters not less than 3-in. high.

Tank refueler trucks used solely on airfields shall be painted No. 14 Brilliant Yellow overall with identification markings in Black. Mobile Boarding Unit Vehicles—

Vehicles owned by the Coast Guard and attached to Mobile Boarding Detachments shall, in addition to the above identification for gray vehicles, have identification markings as follows: A Coast Guard emblem decalcomania 12-in. diameter shall be placed on each side panel of the vehicle body. Place the words "U.S. COAST GUARD" above the decalcomania and the words BOATING SAFETY PATROL below the decalcomania. All lettering shall be No. 29 Bright Blue letters in 4-in. high.

#### (F) SAFETY MARKINGS

Buses and other appropriate vehicles including vehicles assigned to ERS (LL) units, shall

have alternate bands of No. 14 Brilliant Yellow and black applied to front and rear body panels or bumpers. See Safety Color Code, Section 3-16, for further information on this subject. Scotchlite tape of appropriate colors may be used in lieu of paint at the discretion of the District Commander.

### 3-12-2, INTERIOR COLORS

Vehicle (except bus and ambulance) interiors, where painted, shall use the same color as applied to the exterior of the body. Communication trucks shall have a white overhead.

Bus and ambulance and mobile dental unit interiors shall be painted according to the following scheme.

Area	Color
Overhead .....	No. 6 Ivory
Window Section .....	No. 1 Light Green
Lower Bulkheads ... and Seat Backs	No. 2 Medium Green

A decalcomania stating "Penalty For Unauthorized Use of Motor Vehicles" with an explanatory message shall be mounted on the dashboard or instrument panel of all passenger carrying vehicles. These decalcomanias are available from the Commandant (CHS) at no cost.



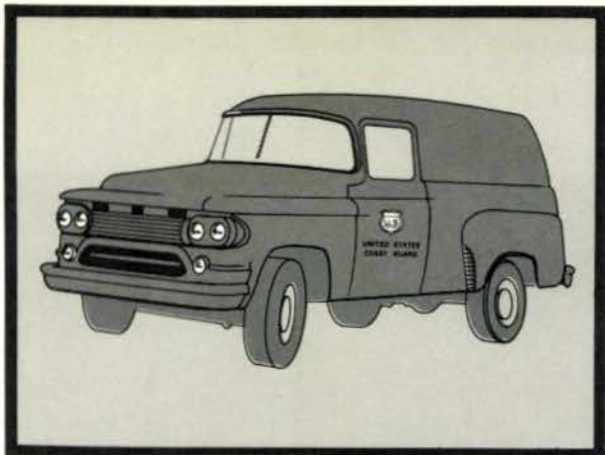

Common vehicles, sedans, trucks, shall be No. 19 Light Gray and shall display insignia.



Buses shall be No. 19 Light Gray. Safety markings in black and No. 14 Brilliant Yellow shall be added.

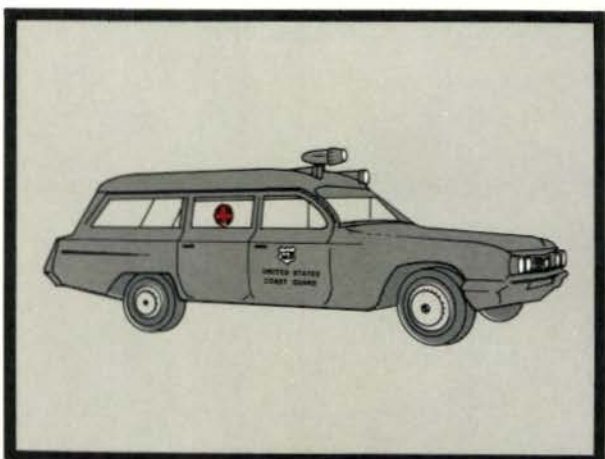

Ambulances shall carry insignia and red cross. Body of vehicle shall be No. 19 Light Gray.

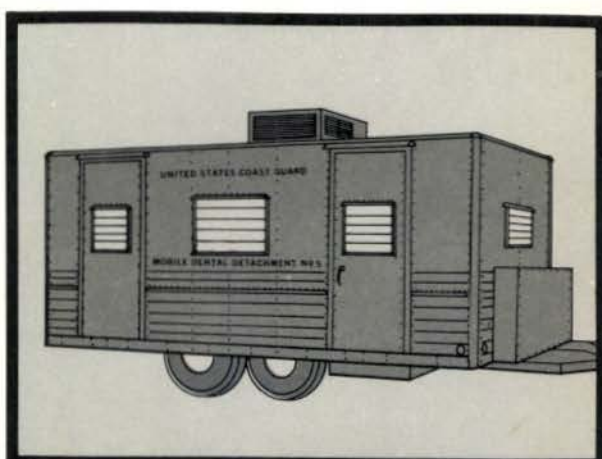

View of Mobile Dental Detachment. Such vehicles should be No. 19 Light Gray. Lettering in No. 29 Blue.

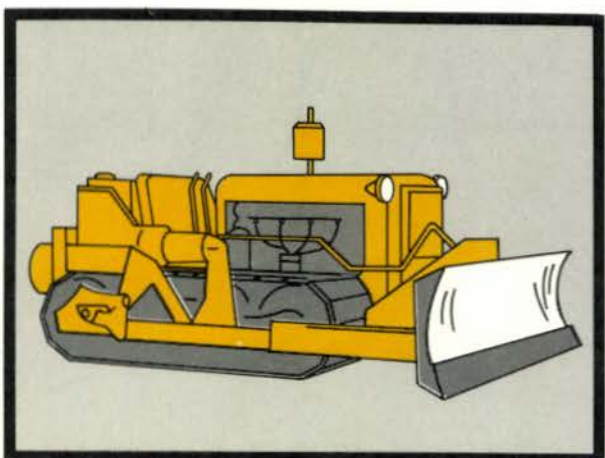

No. 14 Brilliant Yellow is to be applied to bulldozers, materials handling and earth moving equipment.

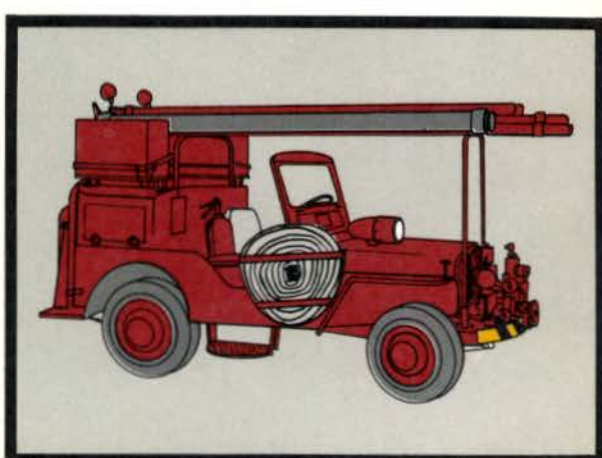

No. 13 Fire Red is standard for fire trucks and for rescue and crash trucks on airfields.



# SECTION 3-13, COLORS FOR VESSELS 65 FEET AND OVER IN LENGTH

The following paragraphs describe the color scheme to be employed on vessels over 65 ft. in length and on harbor tugs of any length. These instructions do not apply to barges which are covered in Section 3-14-1. An attempt has been made to specify the color for all major details. It is obviously impossible to foresee every circumstance which may arise in the future. Therefore, when it is found that the instructions contained herein do not specify the color of a particular detail the general scheme shall be followed. Check against detail specification for vessel class. Article 3-13-1(L) lists those items which are not to be painted.

(A) HULL  
Ship hulls below the boot-topping area shall be painted with the prescribed antifouling paint. See Article 2-3-2.

Ship hulls from the top of the antifouling or underwater area paint up to the top of the hull, bulwark or sheer line, including all fittings, shall be painted in accordance with the accompanying schedule.

On steel, iron or plastic vessels the boot-topping area shall be defined as follows: the bottom edge of the boot-topping shall coincide with the normal light operating waterline of the vessel. For vessels 150 ft. and over in length the top edge of boot-topping shall, at amidships, be above the normal full load waterline a distance equal to 1/8 the freeboard measured to the full load waterline. For vessels less than 150 ft. in length

## 3-13-1, EXTERIOR COLORS FOR VESSELS 65 FEET AND OVER IN LENGTH

<i>Class of Vessel</i>	<i>Boot-topping Area</i>	<i>Above Boot-topping</i>
WAG	Black	White
WAGB	"	"
WAVP	"	"
WAGO	"	"
WIX	"	"
WPC	"	"
WPG	"	"
WSC	"	"
WPB	"	"
WAK	Red	Black
WLB	"	"
WLM	"	"
WLI	"	"
WLIC	"	"
WLR	"	"
WAT	Black	White
WYTL	Red	Black
WLV (Except LAKE HURON)	Black	Red
	Red	Black
WTR	Black	White
WATF	"	"
WYTM	Red	Black
WATA	Black	White

### 3-13-1

this distance shall equal  $1/6$  the freeboard measured to the full load waterline. At the bow the distance from the upper edge of the boot-topping to the full load waterline shall be 1.33 times the distance amidships above the full load waterline, and at the stern the distance from the upper edge to the full load waterline shall be 0.66 times the amidships distance.

On wooden vessels the bottom edge of the boot-topping shall coincide with the *full load* waterline of the vessel. The upper edge of the boot-topping shall be identical with that described above for steel, iron and plastic vessels. Where metal sheathing is installed in way of the boot-topping area the instruction for steel vessels shall be followed.

Limited Drafting Marks are marks designating the maximum draft to which a vessel may be loaded. If Headquarters has issued a limiting draft to the vessel, the mark will be applied. The letter of authorization will locate the marks by stating the limiting draft and freeboard of the vessel as well as the frame number on which the mark will be centered. This is illustrated.

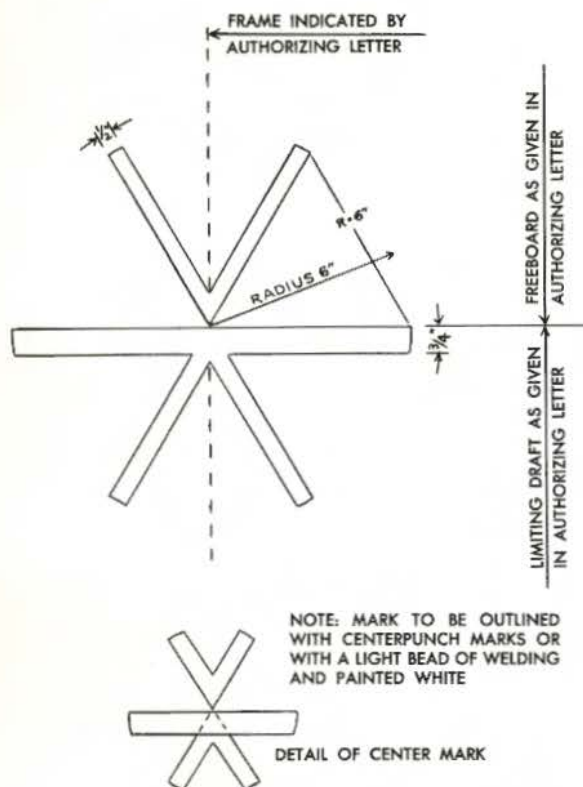

### (B) SUPERSTRUCTURE

The superstructure and all attachments there-to shall be white. This includes the following:

- Deck Houses
- Aircastles
- Breakwaters
- Cabins
- Pilot Houses
- Engine Trunks
- Gun Tubs
- Gun Shields
- Bridge Wings

Canvas dodgers attached to superstructure, bulwarks or bridge wings.

Bulwarks, bulwark supports and brackets. (Except that bulwarks forming an extension of the hull shall be painted the hull color outboard.)

Stanchions, lockers, electrical controllers, switch boxes, ventilation ducts, ladders or other details secured to the superstructure.

Ventilation ducts, electrical conduits and pipelines bracketed to the superstructure or immediately adjacent to the superstructure.

Also apply white to overhangs of exterior passageways and shelters and the inboard side of bulwarks and aircastles.

To reduce glare within the pilot house caused by bright sunlight, the underside of the visor over the pilot house windows and the inward side of the spray shield or dodger on the bridge may be painted No. 32 Blue Gray as specified for steel decks at the discretion of the Commanding Officer.

### (C) DECKS

Wood decks shall be left unpainted. Steel decks shall be painted No. 32 Blue Gray. Where there is a coaming at the deck edge the deck paint shall be extended up the inboard surface of the coaming. Deck paint shall also be applied to bounding angles between decks and superstructure or hatch coamings. Where superstructure and hatch coamings are welded to the deck a 4-in. dado of No. 32 Blue Gray may be applied to the vertical surfaces. Dadoes shall not be applied to miscellaneous deck fittings such as bits, chocks, pedestals, stanchions, etc.

Waterways shall be painted No. 32 Blue Gray.



Decks on which zinc silicate is applied can remain their normal gray color in the work area.

Buoy port deck area should be painted No. 14 Brilliant Yellow from the bulwark back 2 ft. Black stripes on the yellow will help to identify this hazardous area.

(D) TOPS OF CABINS, PILOT HOUSES, AND ENGINE TRUNKS

On vessels whose main decks are all wood or nearly all wood the tops of cabins, pilot houses and engine trunks shall be No. 24 Spar except in way of aerial identification markings. Other vessels shall have these areas painted No. 32 Blue Gray.

(E) STACKS

Stacks shall be painted No. 24 Spar with a broad black band around the top of the stack. The width of the band shall be equal to 1/2 the fore and aft diameter of the stack or 1/5 the height of the stack whichever dimension is the smaller. If the stack has a hood the hood shall also be painted black in addition to the above band and shall form an extension of the band.

(F) MAST AND SPARS

Masts (including ladders, crows nests, platforms, etc.), booms, cranes, davits, flagstuffs, jackstuffs, yardarms and their supports and foundations (other than rigging) shall be painted No. 24 Spar if metal, varnished if wood. Equipment secured to the masts such as radar antennas, radomes, searchlights, bull horn, etc. shall also be No. 24 Spar.

Mast areas directly in way of stack gases may be black. Such areas on masts as are painted black when the vessel is commissioned shall be kept painted black in service. The extension of these areas beyond that originally authorized, or the painting of additional areas black without specific authorization from Headquarters is prohibited.

(G) RUNNING LIGHT SCREENS

In order to contain the reflected light from running light screens within the limits allowed by Rules of the Road, light reflections from the forward part of the screen must be kept to a minimum. The geometry of light

screens and the location of the light sources are such that only light emitted by specular reflection lies within the prescribed limits, whereas light emitted by diffuse reflection from the forward part of the screen exceeds the prescribed limits. Therefore, a paint providing a high specular reflection and low diffuse reflection should be used. A high gloss black enamel performs this function best and shall, therefore, be used on running light screens.

(H) DECK MACHINERY

Deck winches, capstan, winch and capstan controllers, sounding machines, and other deck machinery shall be No. 24 Spar.

(I) ORDNANCE EQUIPMENT

Gun and director foundations, with the exception of working parts and nameplates, shall be painted black. This includes 5-in. gun barrels and interior of hedgehog projectors. 50 cal. foundations shall be painted white.

Interior gun mount shields such as 5/38s shall be painted white. Exterior of gun shields, of hedgehog projectors, ready service boxes, and pyrotechnic lockers shall be painted white. In addition, pyrotechnic lockers shall have the word "PYROTECHNIC" stenciled on the box in a conspicuous location, using the largest practical No. 13 Fire Red letters.

81-mm guns and mounts shall be painted with No. 30 Equipment Gray. Fire Control equipment including gun directors shall be painted with No. 30 Equipment Gray.

Detonator boxes shall be No. 13 Fire Red overall with the word "DETONATORS" stenciled in white on the box in a conspicuous location.

Torpedo tubes shall be maintained in the delivered preservation color in accordance with NAVWEPS OP 2411.

Note: Gun deck and associated ordnance equipment shall be No. 30 Equipment Gray.

(J) BOAT DAVITS AND BOAT STOWAGE

Boat davits, boat chocks, blocks, gallows frames and other boat stowage appurtenances shall be No. 24 Spar.

(K) MISCELLANEOUS DETAILS AND FITTINGS

In general, miscellaneous objects whose color

is not specifically prescribed elsewhere in these instructions, shall be painted white if attached or immediately adjacent to some part of the superstructure that is painted white. They shall be painted No. 24 Spar if attached or immediately adjacent to mast, spars, or other objects whose prescribed color is No. 24 Spar. Objects standing alone

on the deck shall also be No. 24 Spar. Stumbling hazards such as deck padeyes, deck clips and other projections shall be painted white for better night visibility.

Refer to the accompanying list of miscellaneous objects most frequently encountered. While not all of these follow the general rules above, most do, and the general rules shall be applied to objects not listed.

### MISCELLANEOUS PAINTING INSTRUCTIONS

For Coast Guard Color Standards See Charts I and II

Anchors stowed in the hawse	Hull color
Anchors stowed against superstructure	White
Anchors stowed on deck	Spar
Antenna Hardware, Radio Receiving (except insulators)	No. 29 Bright Blue
Antenna Hardware, Radio Transmitting (except insulators)	No. 13 Fire Red
Awning Ridgepoles	White
Awning Stanchions	White
Bits, side, mounted on gunwales of harbor tugs	Black
Bits, side, mounted on gunwales of seagoing tugs	No. 24 Spar
Blocks (except those in black areas on mast or stack)	No. 24 Spar
Blocks, cargo handling, as per safety code	No. 14 Brilliant Yellow
Boat Booms	No. 24 Spar
Boarding Ladders	No. 24 Spar
Chocks, bulwark	Bulwark color
Chocks (except bulwark type)	No. 24 Spar
Compass Stands (except binnacle and other parts required to be kept bright)	White
Davits (all types)	No. 24 Spar
Diaphones	No. 24 Spar
Direction Finder Stands and Loops	White
Deck Chests	White
Ensign Staffs	No. 24 Spar
Fire Pump Portable Covers	No. 13 Fire Red
Firemain Valves (except threaded and machined parts)	No. 13 Fire Red
Flag Lockers	White
Flag Staffs	No. 24 Spar
Gangplanks, metal (except aluminum)	No. 24 Spar
Gasoline Drums	No. 14 Brilliant Yellow with GASOLINE in black letters
Gasoline Stowage Racks	No. 24 Spar

## MISCELLANEOUS PAINTING INSTRUCTIONS

Hatch Coamings	No. 24 Spar
Hatch Covers	White
Hose Racks, Saddles and Reels (for fire hose)	No. 13 Fire Red
Jack Staffs	No. 24 Spar
K-Guns	Black
Ladders (except those on masts) including stringers and rails	White
Ladders (on masts)	No. 24 Spar
Liferails (pipe or canvas covered)	White
Life Rafts, Life Buoys and Life Floats	No. 18 International Orange
Life Rings	Fluorescent Orange
Pelorus Pedestals	White
Pilot House, visor, underside (optional with Commanding Officer)	No. 32 Blue Gray
Radio Direction Finder Stands and Loops	White
Radar Antenna	No. 24 Spar
Ready Service Lockers	White
Searchlights (except those on masts)	White
Searchlights (on masts)	No. 24 Spar
Spray shield (Inboard) on bridge (optional with Commanding Officer)	No. 32 Blue Gray
Tiller, Spare, stowed on deck	No. 24 Spar
Tiller, Spare, stowed against bulkhead	White
Rigging (where painted)	Black
Vegetable Lockers (on deck)	White
Ventilators (all types including gooseneck pipe vents not attached or immediately adjacent to the superstructure)	No. 24 Spar
Ventilators attached or immediately adjacent to the superstructure	White

## (L) ITEMS NOT TO BE PAINTED

In general paint shall not be applied to surfaces where it will cause interference with the functions for which the surfaces were

designed, nor shall it be applied to those surfaces which are traditionally kept bright. Refer to the accompanying list of typical items not to be painted and the method of treatment for each.

## ITEMS NOT TO BE PAINTED

Accommodation ladders, wood	Varnish
Applicator, nozzles	Polish
Boat booms, wood	Varnish
Boatswains' chairs	Oiled
Brightwork	Polish and coat with clear plastic or lacquer
Canvas covers (removable)	No coating
Chain, galvanized	No coating
Deck treads, non-skid	No coating

## ITEMS NOT TO BE PAINTED

Deck, wood	No coating
Dogs	No coating
Fire hose nozzles	Polish
Gangplanks, wood	Oiled or varnished
Gangplanks, aluminum	No coating
Gaskets, inflatable, cargo hatches	Silicone oil
Gaskets, rubber for water-tight doors	Pulverized graphite
Glass	No coating
Gratings, wood	Oiled
Grease cups	No coating
Gypsy head whelps	No coating
Hose	No coating
Insulators	No coating
Knife edges on watertight doors and hatches	Clean with aluminum oxide abrasive cloth, grit #320
Ladders, pilot	Oiled
Leather coverings	Oiled with preservative (Neats Foot Oil)
Masts and spars, wood	Varnish
Name plates	No coating, polish if brass
Oars	No coating
Oil cups	No coating
Oil holes	No coating
Railing, wood	Varnish
Release mechanisms	Greased
Rigging, running	Greased
Rigging, standing	Apply preservative
Searchlight, shutters	No coating
Stages	Oiled
Strongbacks, wood	Varnish
Towing rail (corrosion resistant material)	No coating
Working or machined parts of valves, machinery, blocks, guns or other equipment	Greased or no coating
Zincs	No coating

## (M) DAMAGE CONTROL AND SAFETY MARKINGS

Hose racks, liquid foam containers, spanner wrenches, fire main valves, casualty power terminals and similar equipment used for damage control purposes shall be painted No. 13 Fire Red. Damage control equipment stored in lockers shall be identified by a

suitable label painted on the locker door in No. 13 Fire Red. Covers of all sound power jack boxes and switch boxes shall also be No. 13 Fire Red.

Gasoline and other flammable liquid containers shall be painted No. 14 Brilliant Yellow with the name of the contents conspicuously indicated in large black letters.

Stumbling hazards such as deck padeyes, deck clips and other small projections from the deck shall be painted white for better night visibility.

In painting the above markings do not paint those surfaces listed in paragraph (L).

(N) COMPRESSED GAS CYLINDER IDENTIFICATION

Vessels shall follow the color scheme set forth in Section 3-18, Compressed Gas Cylinder Identification.

(O) MARKINGS ON FLOATABLE EQUIPMENT

Ring Type Life Buoys. The vessel's name, or if not named, or practicable, the vessel's number shall be placed on the top semicircle of the ring. On the bottom semicircle the legend U.S. COAST GUARD shall appear. Black letters 2 in. high shall be used.

Life Rafts. Markings shall always be placed on the longer legs of the raft. The vessel's name, or if not named, the vessel's number, shall be placed on one leg and the legend U.S. COAST GUARD shall be placed on the other leg. The markings shall be so placed as to be readily seen, and when read in the normal manner of reading the vessel's name or number shall be read first.

Lifejackets. The vessel's name or, if not named, the vessel's number shall be placed across the middle of the back of the life-jacket in letters  $\frac{3}{4}$  in. in height.

Wood Articles. Deck chests, boat boxes, oars or other wood articles which may be washed overboard shall have the vessel's name preceded by USCGC, or designating number preceded by CG, burned into the article in  $\frac{1}{2}$  in. letters so as to leave a clear impression.

(P) ANCHOR CHAIN MARKING

Anchor chain, with the exception of the below markings, is to be painted black. Light vessels shall paint only that part of the chain which is normally out of water when anchored on station. The detachable link between shots, excluding the detachable link for the 5-fathom connecting shot, shall be painted as follows

starting from the anchor end and working inboard:

15-fathom detachable link, No. 13 Fire Red.

30-fathom detachable link, white.

45-fathom detachable link, No. 29 Bright Blue.

60-fathom detachable link, No. 13 Fire Red.

The same manner of marking detachable links shall be continued on to the end of the chain with the exception of the detachable links in the last and next to last shot.

Additional markings shall be as follows: The first link on each side of the 15-fathom detachable link shall be painted white. Each of the white links shall be marked by one turn of wire around the stud.

The first two links on each side of the 30-fathom detachable link shall be painted white. The second link at each side of the detachable link shall be marked by two turns of wire around the stud.

The first three links on each side of the 45-fathom detachable link shall be painted white. The third link at each side of the detachable link shall be marked by three turns of wire around the stud.

The same manner of marking shall be continued on to the end of the chain with the exception of the last and next to the last shot.

All of the links in the next to the last inboard shot shall be painted No. 14 Brilliant Yellow, and all of the links in the last shot inboard shall be painted No. 13 Fire Red.

(Q) COMMENDATION AND SERVICE INSIGNIA

Display of commendation and service insignia is optional. When displayed, they shall consist of replicas of the ribbons of the awards to which the vessel would be entitled under the same rules and regulations as prescribed for the individual:

- (a) Presidential Unit Citation
- (b) Coast Guard Unit Commendation
- (c) Navy Unit Commendation
- (d) All service medals
- (e) All Campaign medals
- (f) All expeditionary medals

(g) Foreign unit awards

(h) Non-U.S. Service awards

Replicas of authorized operation and engagement stars as well as stars representing second and subsequent awards are authorized to be painted on the authorized ribbons.

The sizes and locations designated in the accompanying table shall be adhered to for the ship types listed and shall be used as a general rule for ship types not listed. Where symmetrical arrangements permit, the painted

replicas will be displayed on both sides of the vessel in corresponding locations, port and starboard. See accompanying tabulation.

Painted replicas of commendation and service insignia shall be arranged in the same order as ribbons worn by personnel with a maximum of three replicas in a horizontal line.

The diameter of the operation and engagement stars will be  $\frac{3}{8}$  the width of the ribbon, and the stars shall be painted on the replicas with the point down.

#### PAINTED REPLICAS OF COMMENDATION AND SERVICE INSIGNIA

<i>Type Vessel</i>	<i>Insignia Size</i>	<i>Location</i>
327 WHEC	5 in. wide x 18 in. long	Outboard end of Bridge Bulwark 12 in. below top.
269 WAGB	Same	For'd of Life Buoy on Bridge Bulwark 12 in. below top.
255 WHEC	Same	Outboard end of Bridge Bulwark 6 in. below top.
180 WLB	Same	Same
110 WYTM	3¼ in. wide x 12 in. long	Centered on Superstructure Bulwark between Bridge and Break, frame 20-23, 6 in. below top.

**(R) VISUAL IDENTIFICATION MARKINGS ON HULL**

Vessels (excluding lightships) 65 ft. and over shall be identified by distinctive visual identification markings consisting of numerals, letters, Coast Guard emblem and diagonal stripes.

The size and location of the markings shall be in accordance with the detail drawing of each individual class listed on Coast Guard Plan No. FL-2804-13. The style of lettering described in Chapter 3-22 and illustrated on Coast Guard Plan No. FL-2804-11 shall be used.

All numerals, letters and Coast Guard emblems are available in the form of decals and shall be ordered under Coast Guard Term Contract listed in Bulletin C. G. 304.

The diagonal stripes are to be painted using Coast Guard RED, No. 40; Coast Guard BLUE, No. 41; and white in either epoxy or alkyd gloss enamel to coincide with the existing type of paint on the vessel. Black letters and numerals shall be used on white hulls and white shall be used on black hulls.

**Light Vessels—**

Light vessels shall have the name of the station to which assigned or the word RELIEF as applicable, painted in white on both sides of the hull in the largest letters permitted by the freeboard (about 6 ft.-6 in.). The style of the letters shall be as specified in Section 3-22, Letters and Numerals. Spacing between characters shall be  $2\frac{1}{2}$  units; the spacing between words shall be 5 units.

**(S) AERIAL IDENTIFICATION**

All radio equipped vessels over 82 ft. in length and buoy tenders over 100 ft. in length shall have their international radio call letters in No. 18 International Orange (Federal Color 12197) against a black background area on the largest unobstructed and horizontal clear panel available, such as the superstructure deck, cabin trunk top, engine trunk top, house-top or compass platform. Radio equipped boats and ships that do not have an international radio call sign shall have their designating numerals in this same relative position as far as practicable. The lettering shall be placed athwartships with the top of the characters toward the vessel's bow and shall be as large as can be placed in the space available with a minimum of 3 stroke widths between the end characters and the edge of the black background area. The fore and aft dimension ground area shall extend beyond the top and bottom of the letters to a minimum distance of  $\frac{1}{2}$  the letter height. The style of the letters shall be as specified in Section 3-22, Letter and Numerals, with two unit spacing.

**(T) DRAFT FIGURES**

Draft figures on metal hulls shall be made by running a bead of weld around the outline of draft figures projected on the hull. The figures shall be so located that the bottom of the figure is tangent with the draft it represents measured from the bottom of the keel line extended. Draft figures shall conform to those shown in Section 3-22, Letters and Numerals, and shall be used only on vessels having a full load draft in excess of 4 ft.





## (U) INDIVIDUAL SHIP EMBLEMS

Individual ship emblems shall not be painted on, nor affixed to, the exterior structure of ships; however, the display of an emblem which is in keeping with the dignity of the service at the quarterdeck or gangway is authorized. The following rules apply:

a. Extreme cartoon portrayals are not acceptable.

b. Heraldic designs shall follow the rules of heraldry. In such design, symbolism of a nautical or naval nature shall be accented.

c. To ensure good visibility characteristics, the design should be simple as opposed to cluttered, and emphasis should be placed on good color contrast.

d. Identifiable naval vessels and aircraft shall not be used.

e. Commercial, professional, industrial or copyrighted insignia shall not be used.

f. Mottoes and unit name or designation may be included in the design. Nicknames shall not be used.

g. Badges of qualification, decorations, medals, campaign ribbons, national or state insignia, cap devices or other military devices shall not be used.

h. Individual ship emblems shall be inscribed within a circle, regular polygon, or may be inscribed within a circle with crossed anchors or a shield shape. However, if inscribed within either of the latter, the circle with crossed anchors, or the shield shape shall be in proportions as outlined in the standard Coast Guard emblem for crossed anchors and a shield. Maximum dimensions shall not exceed a circle 15 inches in diameter.

i. Requests for approval of individual ship emblems shall be submitted to the District Commander together with a replica of the design in full color. Following approval, District Commanders shall furnish a copy of the drawing, if made, or an 8" x 10" photograph or other copy, marked to indicate colors if not apparent, to the Commandant (CPI).

j. Direct liaison with the Institute of Heraldry, Dept. of the Army, is authorized for assistance in design or procurement of drawings and molds. Requests should be addressed to:

Commanding Officer  
The Institute of Heraldry  
U.S. Army  
Cameron Station  
Alexandria, Virginia 22314

THE ILLUSTRATIONS ON THE FOLLOWING PAGES REPRESENT A TYPICAL COLOR SCHEME ONLY AND ARE NOT TO BE USED AS A WORKING DRAWING. CONSULT THE TEXT AND/OR THE DETAIL PLAN FOR THE CLASS OF VESSEL INVOLVED.

BIBB CLASS CUTTER

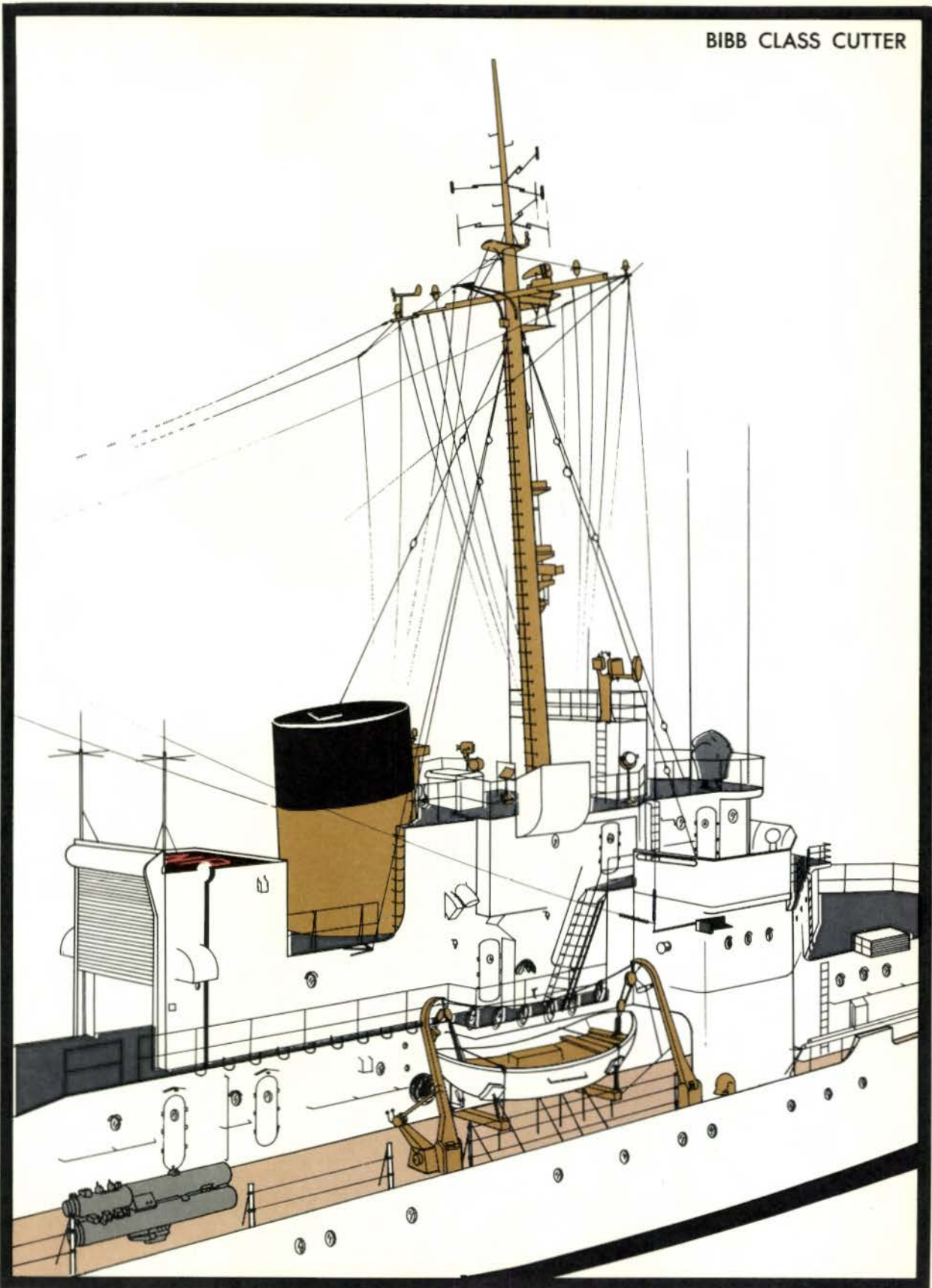



210 FT. RELIANCE

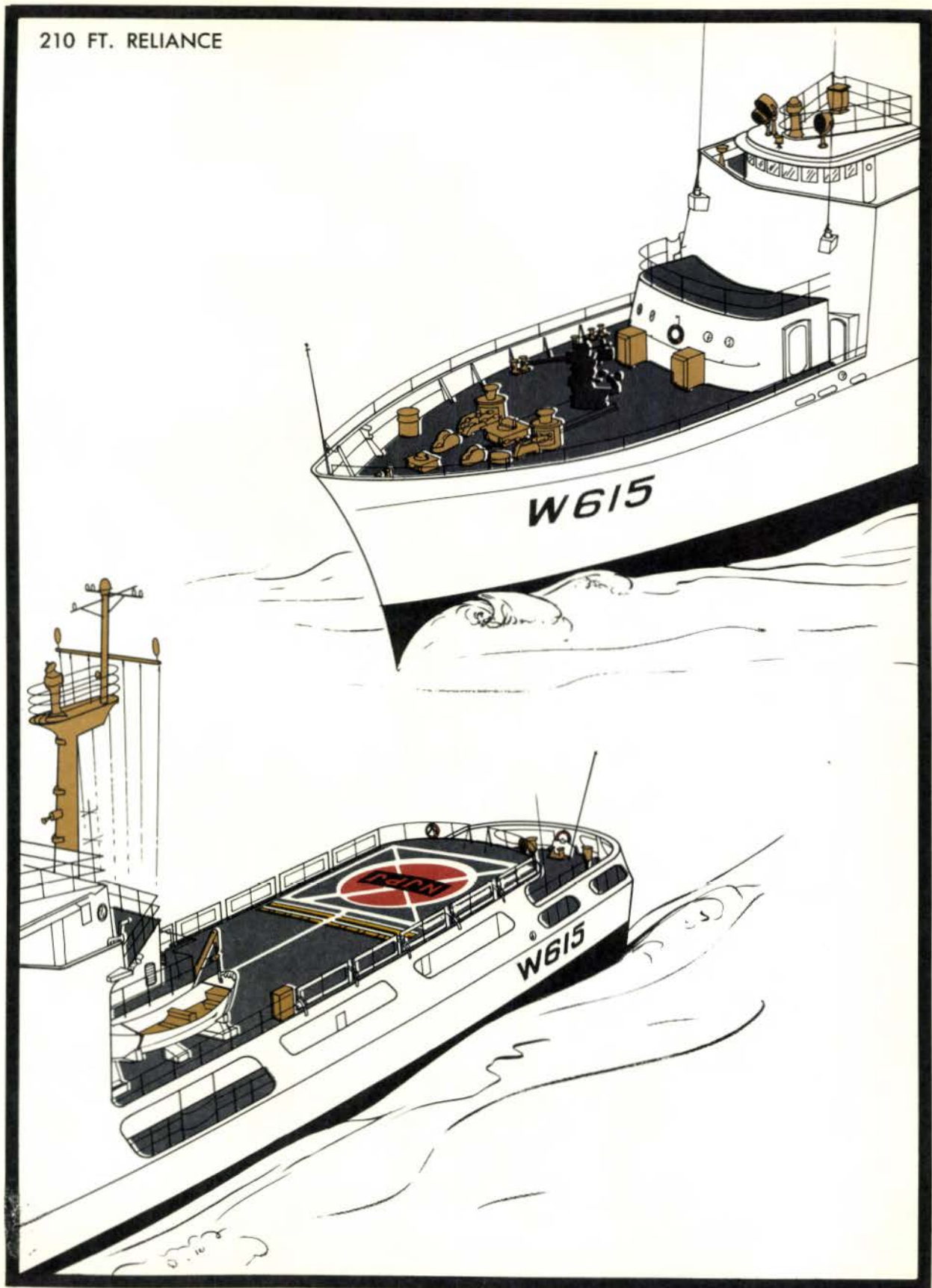



180 FT. CLASS C BUOY TENDER



82 FT. PATROL BOAT







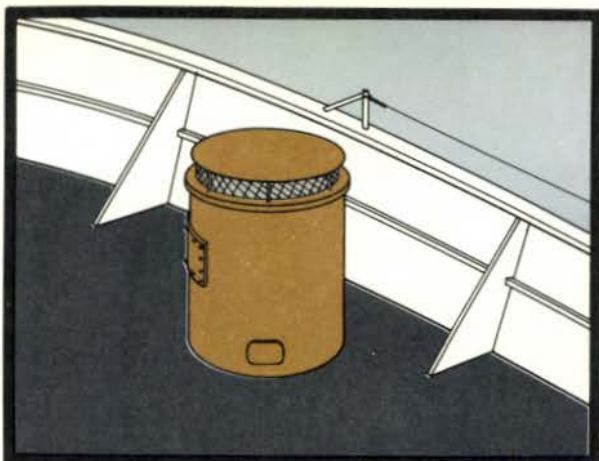

White for superstructure. No. 32 Blue Gray for steel decks. No. 24 Spar for masts, spars, vents and blowers.

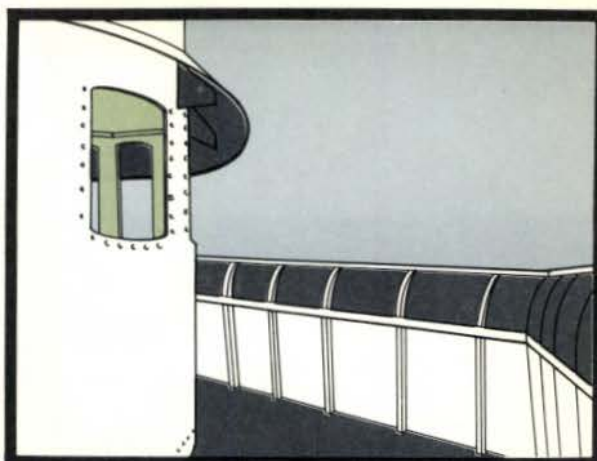

No. 32 Blue Gray for the underside of pilot house visor and for the dodger on the bridge to curtail glare.

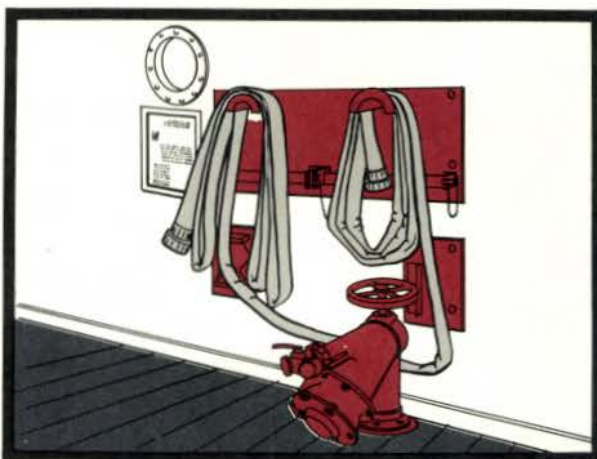

No. 13 Fire Red is mandatory for hose racks, fire mains, and fire and damage control equipment in general.

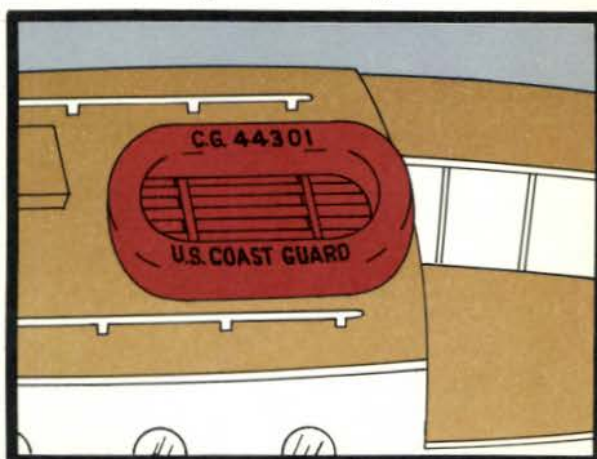

Life buoys, rafts and emergency floatable equipment shall be painted No. 18 International Orange.



Anchor chain is to be black and coded with red, white and blue connecting links to indicate fathom lengths.



Aerial identification numbers and helicopter landing areas shall be clearly marked.



**3-13-2, INTERIOR COLORS FOR  
VESSELS 65 FEET AND OVER  
IN LENGTH**

**(A) COMPARTMENT COLORS—  
SYSTEM A**

Color System A is applicable to all vessels 65 ft. and over in length and harbor tugs unless approval for the use of Color System B has been specifically authorized.

Where the overhead color is different from the bulkhead color the overhead color shall be extended down to the level of the bottom of the overhead beams.

Ducts, pipes and cables are to be painted the same color as the overhead or bulkhead along which they run.

Door frames for both watertight and joiner

doors shall be No. 30 Equipment Gray.

Stanchions adjacent to bulkheads shall be painted the bulkhead color. All other stanchions shall be No. 30 Equipment Gray. Stanchions shall have the same height and color dado as is supplied to the bulkheads.

Deck paints may be extended up adjoining bulkheads to form a dado 4 to 8 in. in height. Dado shall be brought up to the bottom of the doors. Kick pipes shall be painted the dado color. Installed deck coverings shall not be painted but at time of installation shall be procured in colors which most nearly match the prescribed deck colors. Deck coverings which are dark in color or which clash with prescribed color principles are not to be used.

Colors called out in specifications or service manuals to improve habitability shall be perpetuated unless otherwise directed.

**COMPARTMENT COLORS—SYSTEM A**

*Color Principle*

Principle No. 1	Bulkheads, No. 1 Light Green Overheads, White Deck, No. 31 Deck Green	Cabins Officers' Staterooms Wardrooms Sick Bays (Berthing Area Only) Weathermen's Berthing Passageways in Officers' Country
Principle No. 2	Bulkheads, No. 1 Light Green Overheads, White Deck, No. 19 Light Gray	Radio Room Offices (Ship's, Engineer's, First Lt's., Aerological, etc.) Barber Shops Crew's and CPO Quarters
Principle No. 3	Bulkheads, White Overheads, White Deck, No. 19 Light Gray	Crew's Messing Spaces Balloon Shelters Store Rooms Magazines IC Rooms Passageways not in Wardroom Country, Sanitary or Machinery Spaces
Principle No. 4	Bulkheads, White Overheads, White Deck, No. 26 Tile Red	Galleys Sculleries Pantries Heads Laundries

## COMPARTMENT COLORS—SYSTEM A

Principle No. 4 (continued)		Miscellaneous Sanitary Spaces Engine Rooms Boiler Rooms Steering Engine Room Anchor Windlass Room Motor Rooms Emergency Generator Room Passageways in Machinery or Sanitary Spaces Shops
Principle No. 5	Bulkheads, No. 1 Light Green Overheads, No. 1 Light Green Deck, No. 19 Light Gray	Pilot House Chart House
Principle No. 6	Bulkheads, No. 2 Medium Green Overheads, No. 2 Medium Green Deck, No. 19 Light Gray	CIC Sonar Rooms Radar Rooms

(B) COMPARTMENT COLORS —  
SYSTEM B

Color System B consists of the six color principles used in Color System A plus six additional color principles. This system with its greater color variety is designed for use on larger vessels or vessels remaining at sea for extended periods. Use of this color system on vessels is optional, provided no additional paint storage space is required.

Two new colors and principles have been introduced since the first edition of the Manual, 1952. These are No. 23 Turquoise (Principle No. 2) and No. 7 Coral (Principle No. 10). Both colors are fairly rich in hue and medium in tone. Their purpose is to introduce variety and to serve as alternates to more conservative tints such as No. 1 Light Green and No. 25 Beach Sand. It will be noted that the No. 23 Turquoise and No. 7 Coral are limited in application to wardrooms, messing spaces and recreation areas.

Where the overhead color is different from the bulkhead color the overhead color shall

be extended down to the level of the bottom of the overhead beams.

Ducts, pipes and cables are to be painted the same color as the overhead or bulkhead.

Door frames for both watertight and joiner doors shall be No. 30 Equipment Gray.

Stanchions adjacent to bulkheads shall be painted the bulkhead color and all other stanchions shall be No. 30 Equipment Gray. Stanchions shall have the same height and color dado as is applied to the bulkheads.

Deck paints may be extended up adjoining bulkheads to form a dado 4 to 8 in. in height. Dado shall be brought up to the bottom of the doors. Kick pipes shall be painted the dado color. Installed deck coverings shall not be painted but at time of installation shall be procured in colors which most nearly match the prescribed deck colors. Deck coverings which are dark in color or which clash with the prescribed color principle are not to be used.

Colors called out in specifications or service manuals to improve habitability shall be perpetuated unless otherwise directed.

## COMPARTMENT COLORS—SYSTEM B

*Color Principle*

Principle No. 1	Bulkheads, No. 1 Light Green Overheads, White Deck, No. 31 Deck Green	Cabins Officers' Staterooms Wardrooms
-----------------	---	---

## COMPARTMENT COLORS—SYSTEM B

Principle No. 1 (continued)	Bulkheads, No. 1 Light Green Overheads, White Deck, No. 31 Deck Green	Sick Bays (Berthing Area Only) Survivors' Quarters Weathermen's Berthing Warrant Officers' Berthing Offices (Ship's, Engineer's, First Lt's., Aerological, etc.) Radio Rooms
Principle No. 2	Bulkheads, No. 23 Turquoise Overheads, White Deck, No. 19 Light Gray	Wardrooms CPO Messing Spaces Crew's Messing Spaces Crew's Recreation
Principle No. 3	Bulkheads, No. 1 Light Green Overheads, White Deck, No. 19 Light Gray	Offices Communications Rooms Radio Rooms Radio and Electronic Workshops Barber Shops Passageways
Principle No. 4	Bulkheads, White Overheads, White Deck, No. 19 Light Gray	IC Rooms Storage Lockers Storerooms and Magazines Passageways and Lobbies in storeroom areas
Principle No. 5	Bulkheads, White Overheads, White Deck, No. 26 Tile Red	Galleys Sculleries Pantries Heads Laundries Steering Engine Rooms Steering Gear Room Anchor Windlass Rooms Emergency Generator Room Auxiliary Machine Rooms Boiler Rooms Engine Rooms Motor Rooms
Principle No. 6	Bulkheads, No. 1 Light Green Overheads, No. 1 Light Green Deck, No. 19 Light Gray	Pilot House Chart House
Principle No. 7	Bulkheads, No. 2 Medium Green Overheads, No. 2 Medium Green Deck, No. 19 Light Gray	CIC Sonar Rooms Radar Rooms
Principle No. 8	Bulkheads, No. 1 Light Green Overheads, White Deck, Where no deck covering is used, paint No. 26 Tile Red. Where deck covering is used, paint mar- gin area and dado No. 31 Deck Green.	CPO Berthing Spaces Crew's Berthing Spaces

## COMPARTMENT COLORS—SYSTEM B

Principle No. 9	Bulkheads, No. 25 Beach Sand Overheads, White Deck, No. 19 Light Gray	CPO Messing Spaces Crew's Messing Spaces Crew's Recreation Dispensaries
Principle No. 10	Bulkheads, No. 7 Coral Overheads, White Deck, No. 19 Light Gray	CPO Messing Spaces Crew's Messing Spaces Crew's Recreation Hobby Rooms
Principle No. 11	Bulkheads, No. 4 Soft Yellow Overheads, White Deck, No. 19 Light Gray	Shops (Machine, Electric, Carpenter, Damage Control, etc., except Radio and Electronic Workshops) Post Offices Retail Stores Balloon Shelters
Principle No. 12	Bulkheads, No. 4 Soft Yellow Overheads, White Deck, No. 26 Tile Red	Passageways in living and working areas Hobby Rooms

(C) BILGES, VOIDS AND  
COFFERDAMS

Bilges shall be the red color of Quick Drying Red Lead Primer prescribed for bilge painting, or as stated in construction or alteration specifications.

(D) DOORS, HATCH COVERS,  
AND ACCESS PLATES

Watertight doors and raised hatch covers shall be white. Flush deck hatches shall be the color of the deck. Joiner doors shall be No. 30 Equipment Gray. Access plates, other than fuel oil or diesel oil tank tops, shall be the color of the overhead, bulkhead or deck through which they provide access. Tank tops for fuel oil or diesel oil tanks shall be No. 13 Fire Red.

(E) FURNITURE, FIXTURES  
AND EQUIPMENT

Painted metal surfaces of furniture, fixtures and equipment such as desks, tables, chairs, dressers, lockers, cabinets, switch boxes, lighting fixtures, connection boxes, controllers, switchboards, etc., shall be No. 30 Equipment Gray. Exception: equipment received with baked on enamel finish shall not be repainted for color purposes alone. When repainting is necessary the above system shall be followed.

Gray linoleum closely matching No. 9 Pearl Gray or No. 30 Equipment Gray is recommended for desk tops. Linoleum or plastic laminates in gray, off-white, blue or green colors and solid, linen or marbelized patterns may be used for mess tables, benches and counter tops.

(F) MACHINERY AND MACHINE  
TOOLS

Engines (including main propulsion engine and motors), motors, generators, machinery and machine tools shall be painted No. 30 Equipment Gray. Working areas on machine tools, except those surfaces to be left bright, shall be No. 22 High-Light Buff. Switch boxes and starting boxes shall be No. 29 Bright Blue. Dangerous surfaces likely to cut, burn, shock or crush operators shall be No. 18 International Orange. Machined working surfaces such as cutting edges, threads, and sliding parts shall be left unpainted. For additional information on this subject refer to Section 3-17, Machinery Colors.

(G) DAMAGE CONTROLS  
AND SAFETY MARKINGS

Hose racks, liquid foam containers, spanner wrenches, fire main valves, casualty power

terminals, submersible pump outlets, battle lanterns and similar equipment used for damage control purposes shall be painted No. 13 Fire Red. Plastic battle lanterns shall remain as originally furnished.

#### (H) SAFETY COLOR MARKINGS

Gasoline and other flammable liquid containers shall be painted No. 14 Brilliant Yellow with the name of the contents conspicuously indicated in large black letters.

Stumbling, striking, and falling hazards shall be painted No. 14 Brilliant Yellow. Since interiors of vessels contain large numbers of such hazards discretion must be used in applying No. 14 Brilliant Yellow to prevent overusage of this intense color. In general these colors shall be applied only to hazards where experience indicates its application would serve a useful purpose.

#### (I) COMPRESSED GAS CYLINDERS

Vessels shall follow the requirements set forth in Section 3-18, Compressed Gas

Cylinder Identification.

#### (J) HEATED SURFACES

Surfaces whose operating temperature is above 300° F. shall be painted aluminum with Heat-Resisting Paint.

#### (K) LADDERS AND COMPANIONWAYS

Metal ladders and companionways shall be No. 30 Equipment Gray. Aluminum ladders shall remain unpainted. This includes stringers, clips, piperails, pipe stanchions, tread support rungs and screens. Stainless steel or composition treads and uncovered galvanized chain handrails shall not be painted.

Wood ladders and companionways shall be varnished. Stainless steel, aluminum or galvanized parts shall not be painted. Non-corrosion resistant parts shall be No. 30 Equipment Gray.

#### (L) SURFACES NOT TO BE PAINTED

Those surfaces listed under article 3-13-1(L) shall not be painted.







Principle 2 for a wardroom. No. 23 Turquoise bulkheads, No. 19 Light Gray deck. Furniture in red and gray.

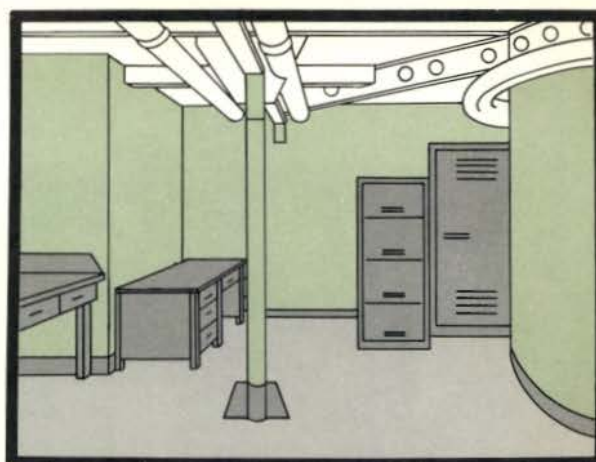

Principle 3, No. 1 Light Green bulkheads, No. 19 Light Gray deck is applied to offices, radio rooms, radio workshops.

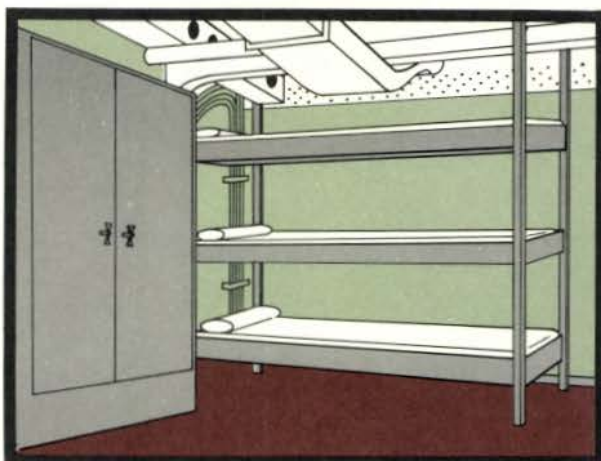

Principle 8, crew's berthing, white overhead, No. 1 Light Green bulkheads, No. 26 Tile Red floors. Gray equipment.



Principle 10 for crew's mess and recreation uses No. 7 Coral for bright and cheerful variety.

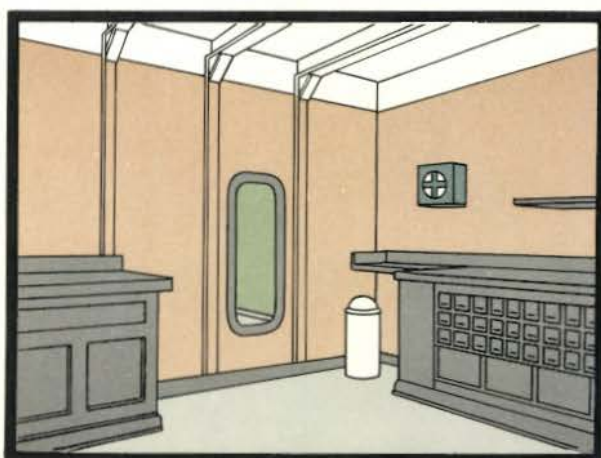

The dispensary in No. 25 Beach Sand, with the sick bay in No. 1 Light Green, offers pleasing harmony.

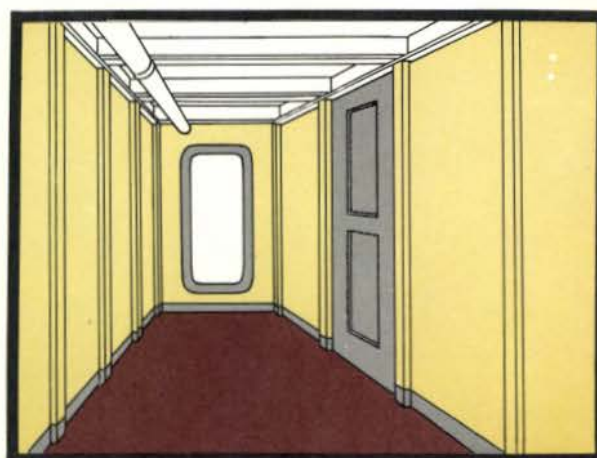

Principle 12 in passageways uses No. 4 Soft Yellow with No. 30 Equipment Gray trim for a sunny effect.



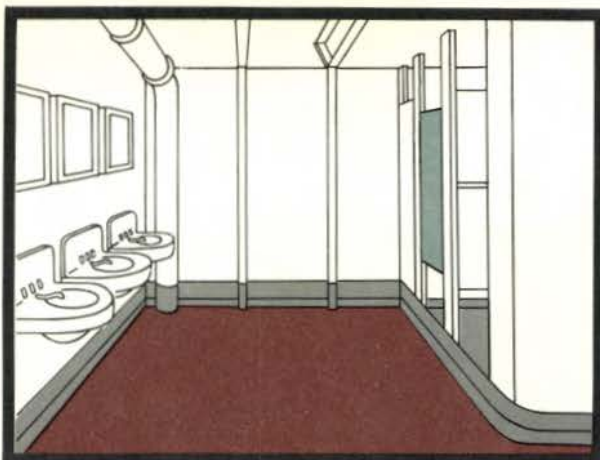

Principle 5 in heads uses white with No. 26 Tile Red for deck to encourage cleanliness and good maintenance.

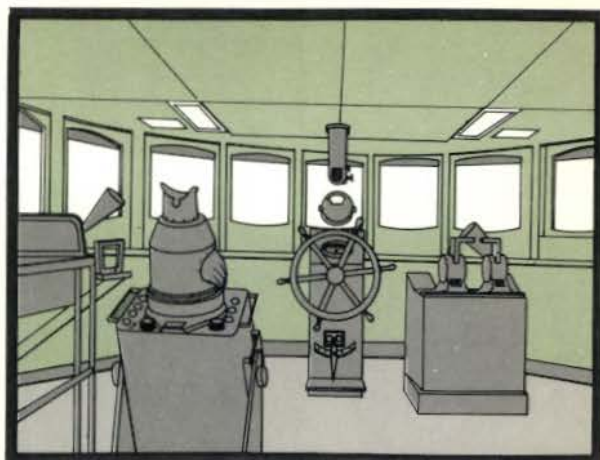

In the Pilot House, No. 1 Light Green (Principle 6) is used for bulkheads and overhead to curtain glare.

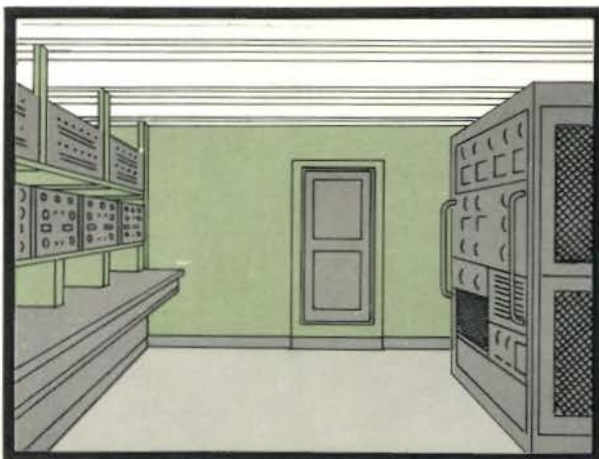

Radio rooms take Principle 3, which combines white overhead, No. 1 Light Green bulkheads and gray deck.

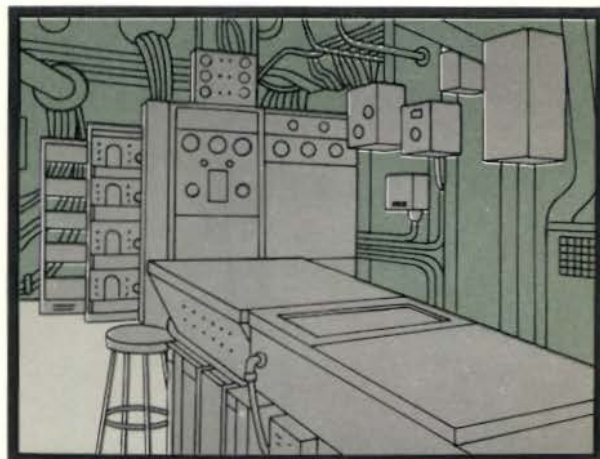

For CIC, to aid dark adaptation, No. 2 Medium Green (Principle 7) is used for good visibility.

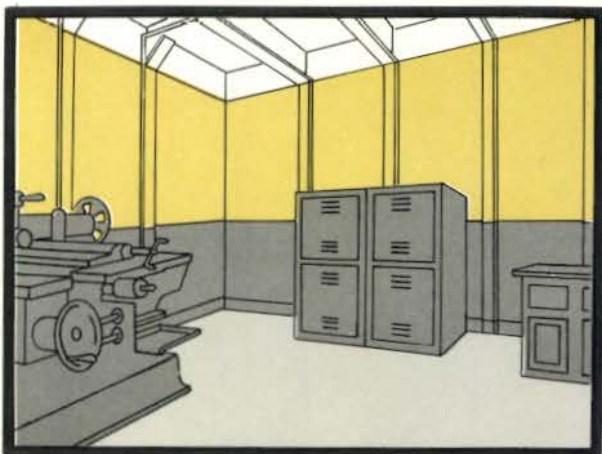

Principle 11 in shops combines No. 4 Soft Yellow with No. 19 Light Gray deck to relieve monotony.

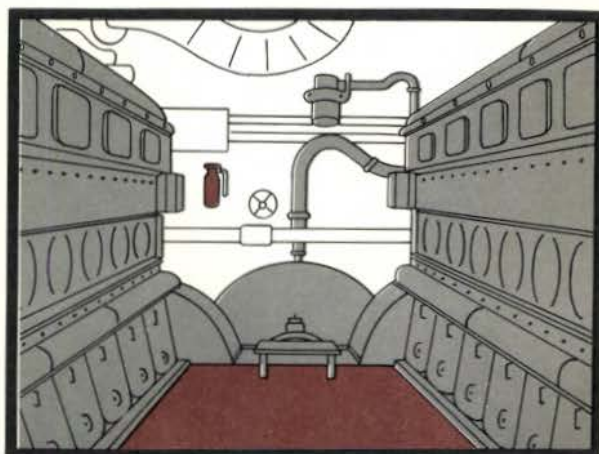

Engine room (Principle 5) uses white with No. 26 Tile Red deck and No. 30 Equipment Gray on machinery.



## SECTION 3-14, COLORS FOR VESSELS LESS THAN 65 FEET IN LENGTH

The following paragraphs describe the color scheme to be employed in vessels less than 65 ft. in length and on barges of any length. These instructions do not apply to harbor tugs which are covered by Section 3-13. Due to the great variety of small boat types it is impractical to write painting instructions for every item. When situations arise which are not specifically provided for by the following instructions, reference should be made to design specification and the general color scheme.

### 3-14-1, EXTERIOR COLORS FOR VESSELS LESS THAN 65 FEET IN LENGTH

#### (A) HULL

Vessels of this class (motor lifeboats, utility boats, etc.) with the below exceptions shall have white hulls above the boot-topping area. For the painting of hulls below the boot-topping area refer to Article 2-3-2(E) and (F).

On steel or plastic vessels the boot-topping area shall be defined as follows: the bottom edge of the boot-topping shall coincide with the light load waterline of the vessel. The top edge of the boot-topping shall, at amidships, be above the full load waterline a distance equal to  $\frac{1}{4}$  the freeboard measured to the full load waterline. At the bow the height of the top edge of the boot-topping above the full load waterline shall be equal to twice that amidships. At the stern the height of the top edge of the boot-topping above the full load waterline shall be equal to that amidships. All measurements are to be taken in a vertical plane and projected on to the hull.

Where rubbing rails or spray rails located along the quarter of the vessel interfere with or lie close to the top edge of the boot-topping, the height of the boot-topping shall be adjusted the minimum amount to be either

completely above or completely below the rubbing or spray rails and shall normally be parallel to these rails.

New construction boats may require some variation or exception to the above noted criteria. However, in all cases the top edge of the boot-topping shall be a fair and optically pleasing curve from stem to stern.

On wooden boats the bottom edge of the boot-topping shall coincide with the *full load* waterline of the vessel. The upper edge of the boot-topping shall be identical with that for steel and plastic vessels. Where metal sheathing is installed in way of the boot-topping area the instructions for steel vessels shall be followed.

Exceptions to the above rule are as follows:

(a) Barges, Buoy Boats and LCMs shall have black hulls above the upper edge of the antifouling paint. The upper edge of the antifouling paint shall coincide with the full load waterline.

(b) Flood Relief Punts shall have No. 18 International Orange hulls, including the underwater area.

(c) LARCs shall have white hulls including the underwater area except that wheels and wheel wells shall be black.

(d) TICWAN boats shall have black hulls including underwater area.

(e) Hulls of shipboard boats, motor cargo boats and selected plastic boats shall be white including underwater area.

#### (B) SUPERSTRUCTURE

Cabins, pilot houses, engine trunks extending appreciably above the sheer line, hatches and other superstructure shall be painted white on the vertical surfaces. The horizontal surfaces shall be No. 32 Blue Gray if steel and No. 24 Spar if of wood, plastic or canvas. Utility boats shall be No. 24 Spar. Where there is no distinct demarcation between vertical and horizontal surfaces, such as in the canopies of gigs and the cabins of the 36 ft. motor

### 3-14-1

lifeboat, the white color shall be used over the entire canopy or cabin.

#### (C) DECKS

Decks shall be No. 24 Spar with exception of 44 ft. cargo boats and steel utility boats which shall have No. 32 Blue Gray decks. LCMs and barges shall have black decks.

#### (D) INSIDE OF OPEN HULLS, COCKPITS AND CARGO SPACES

The inside of open hulls and the cockpits and cargo spaces of decked hulls shall be white down to the side seats or risers, if any, or down to the cockpit deck, grating or floor boards if there be no side seats or risers. No. 24 Spar shall be applied below the white including seats, thwarts, inside of hull, cockpit decks, gratings, floor boards or open bilges. Engine trunks not extending appreciably above the sheer line shall be No. 24 Spar overall. This color scheme shall apply to all boats except as noted below.

40 ft. Utility Boats shall have No. 32 Blue Gray cockpit decks.

LCMs, Barges and Buoy Boats shall have the entire interior of their cargo spaces black. Exception: work barge storerooms shall have a white overhead and bulkheads. A gray dado may be used. See Article 2-3-13, Spaces Subject to Heavy Sweating.

LARCs and motor Cargo Boats shall have the entire interior of their cockpit and cargo space painted No. 24 Spar.

Flood Relief Punts shall have the entire interior, including hull, thwarts, floor boards, and bilges No. 18 International Orange.

#### (E) HULLS OF SHIPBOARD BOATS

Hulls of shipboard boats, motor cargo boats and selected plastic boats shall have white hulls, including underwater area.

#### (F) GUNS AND ORDNANCE EQUIPMENT

For details see 3-13-1(I).

#### (G) RUNNING LIGHT SCREENS

Running light screens shall be painted a high gloss black enamel.

#### (H) MISCELLANEOUS DETAILS AND FITTINGS

In general, miscellaneous metal fittings and equipment shall be painted white if attached or immediately adjacent to some part of the superstructure that is painted white and shall otherwise be painted No. 24 Spar. Wood fittings shall normally be varnished.

LCMs and barges are exceptions to the rule and shall have all miscellaneous objects painted black.

#### (I) ITEMS NOT TO BE PAINTED

In general, paint shall not be applied to surfaces where it will cause interference with the functions for which the surfaces were designed nor shall it be applied to those surfaces which are traditionally kept bright. Refer to the accompanying typical items not to be painted and the method of treatment for each. Also see 3-13-1(L).

#### ITEMS NOT TO BE PAINTED

Anchor chains, galvanized	No coating
Anchors, galvanized	No coating
Boatswains' chairs	Oiled
Brightwork	Polish and coat with clear plastic or lacquer
Canvas covers (removable)	No coating
Chain, galvanized	No coating
Deck treads, non-skid	No coating
Deck, wood	No coating
Dogs	Grease moving parts
Fire hose nozzles	Polish

Gaskets, rubber for water-tight doors	Pulverized graphite
Glass	No coating
Gratings, wood	Oiled
Grease cups	No coating
Gypsy head whelps	No coating
Handrails and stanchions cold drawn finished	Polish
Hose	No coating
Insulators	No coating
Knife edges on watertight doors and hatches	Clean with aluminum oxide abrasive cloth, grit #320.
Ladders, wood	Oiled
Leather coverings	Oiled with preservative
Masts and spars, wood	Varnish, spar
Name plates	No coating, polish or lacquer, if brass
Oars	No coating
Oil cups	No coating
Oil holes	No coating
Railing, wood	Varnish, spar
Release mechanisms	Greased
Rigging, running	Chain, Gear and Wire Rope Lubricating Grease
Rigging, standing	Thin Film Rust Preventive Grade I
Searchlight, shutters	No coating
Winches (working surfaces)	Rust Preventive only, thin film Grade I
Working or machined parts of valves, machinery, blocks, guns or other equipment	Greased
Zincs	No coating

#### (J) DAMAGE CONTROL AND SAFETY MARKINGS

Hose racks, spanner wrenches, fire-main valves, fire axes and similar fire fighting equipment shall be No. 13 Fire Red. Damage control equipment stored in lockers shall be identified by a suitable label painted on the locker door in No. 13 Fire Red. Covers of all sound power jack boxes and switch boxes shall also be No. 13 Fire Red.

Gasoline and other flammable liquid containers shall be painted No. 14 Brilliant Yellow with the name of the contents conspicuously indicated in large black letters.

Stumbling hazards such as deck padeyes, deck clips and other small projections from

the deck shall be painted white for better night visibility.

In painting the above markings do not paint those surfaces listed in paragraph (I) above.

#### (K) COMPRESSED GAS CYLINDER IDENTIFICATION

The color schemes set forth in Section 3-18 shall be followed.

#### (L) MARKINGS ON FLOATABLE EQUIPMENT

Ring Type Life Buoys: the vessel's name, or if not named or practicable, the vessel's number, shall be placed on the top semicircle of the ring. On the bottom semicircle the legend U.S. COAST GUARD shall appear. Black letters 2 in. high shall be used.

**Life Rafts:** markings shall always be placed on the longer legs of the raft. The vessel's name or, if not named or practicable, the vessel's number, shall be placed on one leg and the legend U.S. COAST GUARD shall be placed on the other leg. The markings shall be so placed as to be readily seen and when read in the normal manner of reading the vessel's name or number shall be read first.

**Lifejackets:** the vessel's name or, if not named, the vessel's number, shall be placed across the middle of the back of the lifejacket in letters  $\frac{3}{4}$  in. in height.

**Wood articles:** deck chests, boat boxes, oars or other wood articles which may be washed overboard shall have the vessel's name preceded by USCGC or designating number preceded by CG burned into the article in  $\frac{1}{2}$  in. letters so as to leave a clear impression.

#### (M) VISUAL IDENTIFICATION MARKINGS ON HULL

Boats 30 to 65-ft. in Length.

Boats 30 ft. and over and less than 65 ft. (including Larcs) shall be identified by distinctive visual identification markings consisting of numerals, letters, Coast Guard emblem and diagonal stripes.

The size and location of the markings shall be in accordance with the detail drawing of each individual class listed on Coast Guard Plan No. FL-2804-13. The style of lettering described in Chapter 3-22 and illustrated on Coast Guard Plan No. FL-2804-11 shall be used.

All numerals, letters and Coast Guard emblems are available in the form of decals and shall be ordered under Coast Guard Term Contract listed in Bulletin C.G. 304.

Boats for which the distinctive marking is not feasible shall have bow markings as described in the accompanying table and illustration.



Overall Length	A	B	C	D	E
30 ft. and over to 40 ft.	4 in.	2 in.	6 in.	18 in.	*
40 ft. and over to 50 ft.	6 in.	3 in.	9 in.	24 in.	*
54 ft. and over to 65 ft.	8 in.	4 in.	12 in.	30 in.	*

\*E must be equal to or greater than A.

- A = Distance from lower edge of rubbing rail, gunwale, or sheer line to top edge of legend.  
 B = Height of legend.  
 C = Height of designating number.  
 D = Distance from foremost edge of foremost number to stem along the outer surface of the hull.  
 E = Least distance between lower edge of designating number and top edge of boot-topping or waterline if there be no boot-topping.



The diagonal stripes are to be painted using Coast Guard RED, No. 40; Coast Guard BLUE, No. 41; and white in either epoxy or alkyd gloss enamel to coincide with the existing type of paint on the boat. Black letters shall be used on white hulls and white shall be used on black hulls.

The official number of the boat shall be placed on the stern in numerals of the same height as the numerals on the bow. Double ended boats are not required to have the stern markings.

When necessary, due to size and arrangement of the boat, deviation in size and location of the markings may be made to achieve pleasing and legible results.

#### RESERVE TRAINING BOATS

The above requirements shall apply to Reserve training boats. In addition the legend "Reserve" shall be placed under "Coast Guard" in letters  $\frac{1}{2}$  the height of "Coast Guard".

#### BOATS UNDER 30 FT. IN LENGTH

Boats attached to Boating Safety Teams and Shore Units.

Boats under 30 ft. (excluding boats under 15 ft. in length) assigned to Boating Safety Teams and Shore Units shall be identified by distinctive visual identification markings in accordance with the detail drawing listed on Coast Guard Plan No. FL-2804-13. Black letters shall be used on white hulls and white letters on black hulls.

Boats excluded on Coast Guard Plan No. FL-2804-13 shall be identified by the legend "U.S. Coast Guard" in 3 inch high letters. Letters shall be black on white hulls and white on black hulls. If the lettering so located lies across a plank seam the lettering shall be raised or lowered as necessary so as to avoid the seam.

All measurements shall be taken along the hull. For style of lettering see Section 3-22, Letters and Numerals.

As an exception to the rule the boats listed below shall have their legend centered on their sheer plank and located so that the foremost part of the foremost character is 4 in. abaft the stem.

20 ft. Dinghy	16 ft. Dinghy
19 ft. Dory	13 ft. Dinghy
	10 ft. Dinghy

#### Barges—

Barges shall be identified in the same manner as boats 30 ft. to 65 ft. in length except that the prefix CGB shall be substituted for the prefix CG. Barges obtained from the Army or Navy on a Army loan basis shall retain their Navy or Army identification symbols unless otherwise directed by the Commandant. White letters shall be used on black hulls.

#### Boats Assigned To Named Vessels—

Identification markings on boats 20 ft. and over in length assigned to named vessels shall consist of an abbreviation of the name of the vessel to which the boat is assigned followed by a numeral.

The abbreviation of vessel's names to be used for identification markings shall with the exception of those listed herewith, consist of the first three letters of the vessel's name. All letters in the abbreviation shall be 6 in. high. On the following page is a list of authorized abbreviations for vessels which do not fall under the general rule.

The boat numbers which follow the abbreviations shall be 6 in. high and are determined by the location of the boat on the vessel. Starboard boats are assigned odd numbers starting forward and working aft. In cases where boats are stowed one above the other, the upper boat shall have the lower number. Numbers on the bows shall be omitted when only one boat is carried by a vessel.

Markings shall be located on both bows in accordance with the accompanying illustrations.



## ABBREVIATIONS FOR VESSEL IDENTIFICATION

<i>Name</i>	<i>Abbreviation</i>	<i>Name</i>	<i>Abbreviation</i>
APALACHEE	APR	IRIS	IRS
BERING STRAIT	BST	IRONWOOD	IRW
BLACKHAW	BLH	MACKINAW	MAW
BLACKTHORN	BLT	OJIBWA	OJB
BLUEBELL	BLB	PAPAW	PAW
CARTIGAN	CTN	PLANETREE	PLT
CASTLE ROCK	CRO	PRIMROSE	PRM
CLEMATIS	CLM	ROCKAWAY	ROK
CHILULA	CHL	SEDGE	SEG
CHINOOK	CHN	SWEETBRIER	SWB
COLUMBINE	CLB	SWEETGUM	SWG
COOK INLET	CIN	VERBENA	VEB
COOS BAY	CBA	WHITE ALDER	WAL
EVERGREEN	EVR	WHITEBUSH	WBU
EWING	EWN	WHITE HEATH	WHE
FERN	FRN	WHITE HOLLY	WHO
FIREBRUSH	FBU	WHITE LUPINE	WLU
FORSYTHIA	FRS	WHITE PINE	WPI
GENERAL GREENE	GGR	WHITE SAGE	WSA
GOLDENROD	GLD	WHITE SUMAC	WSU
HALF MOON	HMO	WINNEBAGO	WIB
HICKORY	HIK	WOODBINE	WOB
		WOODBUSH	WOR

All measurements shall be taken along the surface of the hull. The spacing between the letters and figures shall be such that they shall be legible at a reasonable distance and present a good appearance.

The letters and numbers used for these markings shall conform in style to Section 3-22.

When applying these markings to clinker built boats, the outside surface of the hull shall be built up to a smooth surface where necessary and the markings shall be parallel to the bottom edge of the plank on which they are secured instead of parallel to the bottom edge of the guard rail.

Identification markings on boats less than 20 ft. assigned to named vessels shall be the same as boats 20 ft. and over assigned to named vessels except that the markings shall be on both bows in 3-in. letters, all capitals. For style of lettering, see Section 3-22, Letters and Numerals.

**Boats Assigned to Numbered Floating Units—**Boats assigned to numbered floating units including lightships and barges shall be identified by placing in the designating number of the unit, such as CG 63005, on both bows in black 3-in. letters. For style of lettering, see Section 3-22, Letters and Numerals.

### 3-14-2, INTERIOR COLORS FOR VESSELS LESS THAN 65 FEET IN LENGTH

The interior colors for vessels less than 65 ft. in length shall consist of one color scheme only as described below.

#### (A) OVERHEADS AND BULKHEADS

Overheads and bulkheads including all pipes, ducts and cables running along the overheads or bulkheads shall be white.

Door frames for both watertight and steel joiner doors shall be No. 30 Equipment Gray. Wood door frames shall be varnished.

Stanchions adjacent to bulkheads shall be painted the bulkhead color. All other stanchions shall be No. 30 Equipment Gray.

#### (B) DECKS

Interior decks shall be No. 19 Light Gray. A dado of the deck color may be extended up adjoining bulkheads for a distance of 4 to 8 in. The dado shall be brought up to the bottom of the doors. Kick pipes shall also be the deck color. Installed deck coverings shall not be painted but shall be procured in a color matching as nearly as possible the No. 19 Light Gray Color.

#### (C) BILGES AND VOIDS

On metal vessels the natural color of the anti-corrosive paint system prescribed for the type of metal used shall be considered the proper bilge color. This should approach #26 Tile Red unless otherwise directed by construction or alteration specifications.

Bilges of wooden boats are not to be painted. The green color of the wood preservative is to be maintained by retreating with preservative as necessary.

#### (D) DOORS, HATCH COVERS AND ACCESS PLATES

Doors shall be No. 30 Equipment Gray. Raised hatch covers shall be white. Flush deck hatches shall be the deck color. Access plates, other than fuel oil or diesel oil tank tops, shall be the color of the surrounding bulkhead or deck.

Tank tops for fuel oil or diesel oil tanks shall be No. 13 Fire Red.

#### (E) FURNITURE, FIXTURES AND EQUIPMENT

Unless otherwise specified by the Commandant, painted surfaces of furniture, fixtures and equipment such as desks, tables, chairs, dressers, lockers, cabinets, switch boxes, lighting fixtures, connection boxes, controllers, switchboards, etc., shall be No. 30 Equipment Gray. Exception: Equipment received with baked on enamel finish shall not be painted for color purposes alone. When repainting is necessary the above system shall be followed.

#### (F) MACHINERY AND MACHINE TOOLS

Engines, (including main propulsion engine and motors), motors, generators, machinery and machine tools shall be painted No. 30 Equipment Gray. Areas on machine tools, except those surfaces to be left bright, shall be No. 22 High-Light Buff. Switch boxes and starting boxes shall be No. 29 Bright Blue. Dangerous surfaces likely to cut, burn, shock or crush operators shall be No. 18 International Orange. Machined working surfaces such as cutting edges, threads and sliding parts shall be left unpainted. For additional information on this subject refer to Section 3-17, Machinery Colors.

#### (G) FIREFIGHTING EQUIPMENT

All equipment used primarily for firefighting shall be painted No. 13 Fire Red.

Stumbling, striking and falling hazards shall be painted No. 14 Brilliant Yellow. Since interiors of vessels contain large numbers of such hazards discretion must be used in applying No. 14 Brilliant Yellow to prevent overusage of this intense color. In general, this color shall be applied only to hazards where experience indicates its application would serve a useful purpose.

#### (H) HEATED SURFACES

Surfaces whose operating temperature is above 300° F. shall be painted aluminum with Heat-Resistant Paint, MIL-P-14276.

#### (I) LADDERS AND COMPANIONWAYS

Metal ladders and companionways shall be

No. 30 Equipment Gray. Aluminum ladders shall remain unpainted. This includes stringers, clips, piperails, pipe stanchions, tread supports, rungs and screens. Stainless steel, aluminum or composition treads and uncovered galvanized chain handrails shall not be painted.

Wood ladders and companionways shall be varnished. Stainless steel, aluminum, composition or galvanized parts shall not be painted.

Non-corrosion resistant parts shall be No. 30 Equipment Gray.

(J) WORKBARGE STOREROOMS

Spaces used for storerooms and workshops shall be painted white with gray dado or as originally specified in construction specifications.

(K) SURFACES NOT TO BE PAINTED

Those surfaces listed under paragraph 3-13-1(L) shall not be painted.



30 FT. UTILITY BOAT

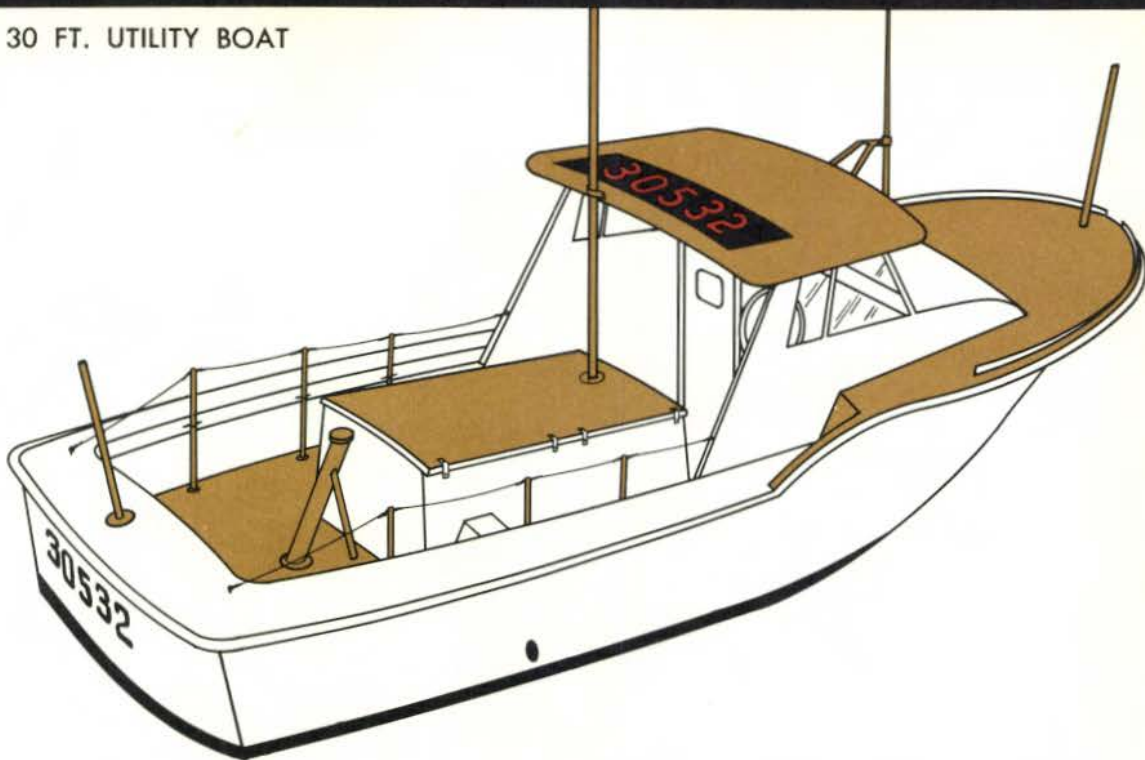

25 FT. 8 IN. MOTOR SURF BOAT

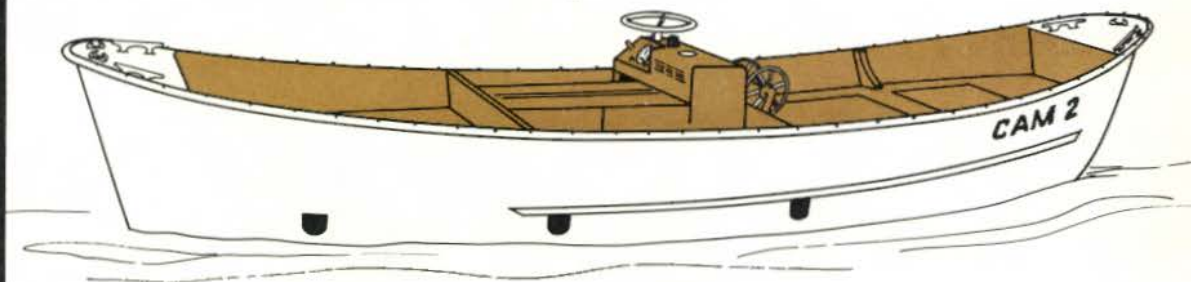

19 FT. TICWAN







16 FT. OUTBOARD MOTORBOAT

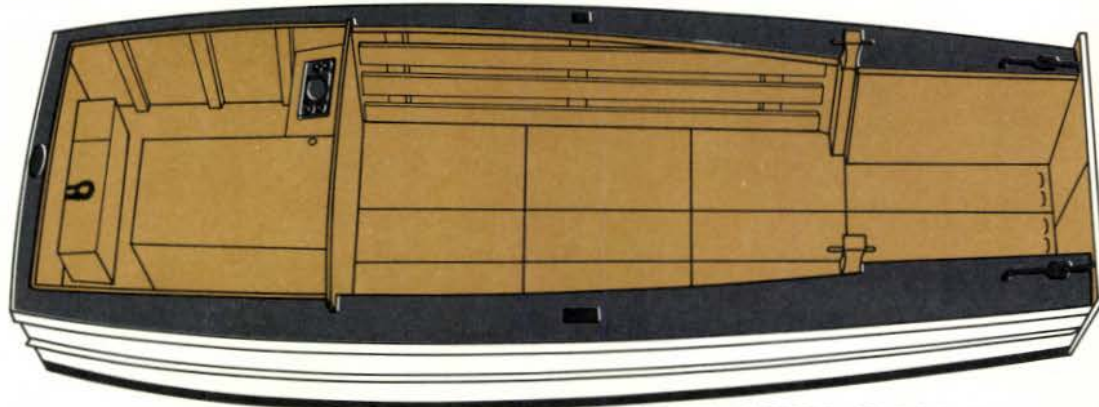
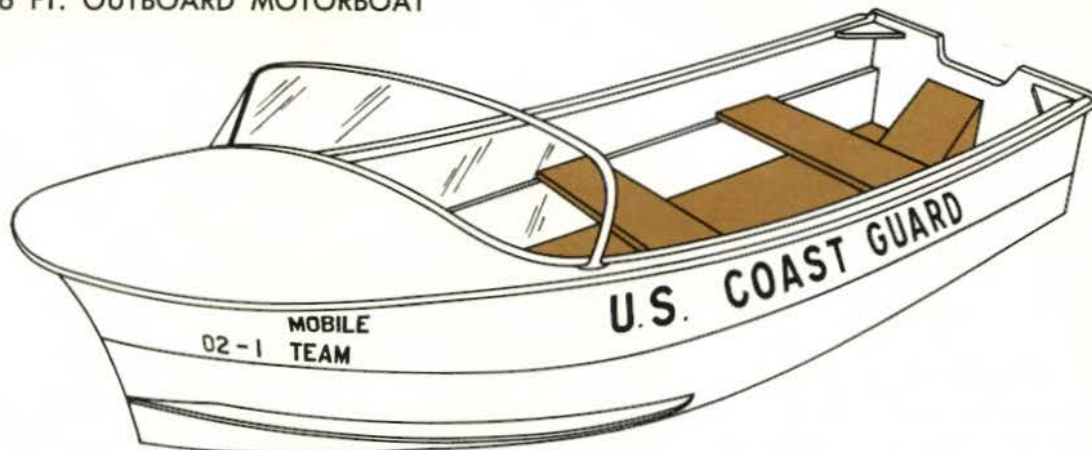

24 FT. MOTOR CARGO RAMP BOAT

LARC

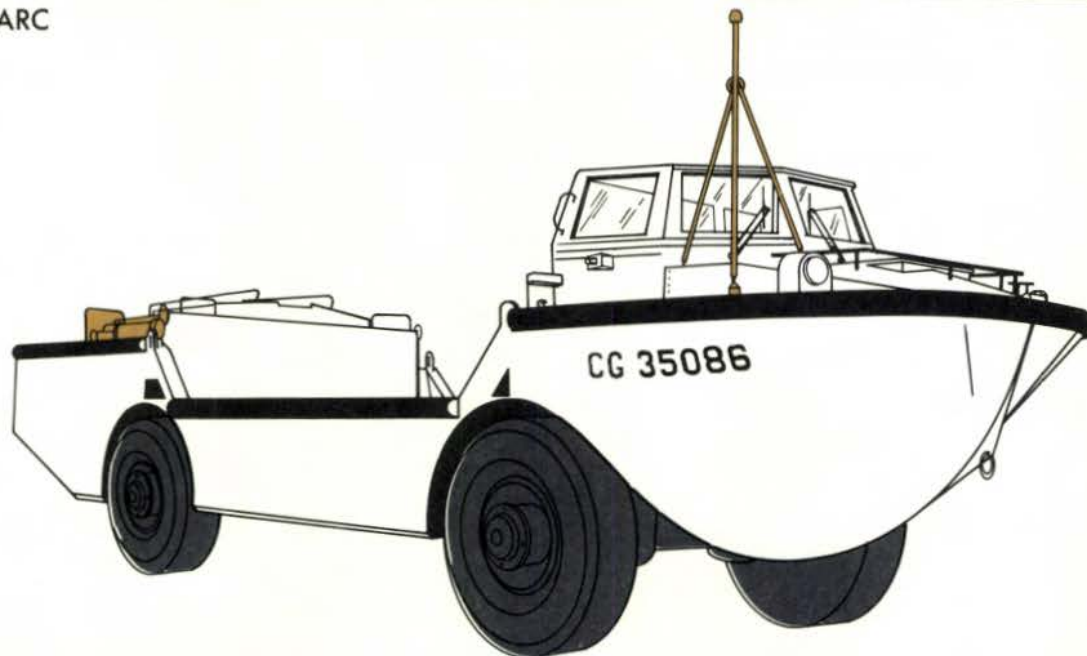



**SECTION 3-15, AIRCRAFT COLORS****3-15-1 GENERAL REMARKS**

Applicable aircraft painting and marking drawings and the related Aviation Technical Note should be referred to for specific painting and marking information. This will assure accurate and up-to-date information concerning aircraft painting. These documents are subject to frequent and periodic revisions in order to keep abreast of the latest aircraft finishes, processes and procedures. They can be requisitioned from Commandant (CHS) in

accordance with CG-236, DIRECTIVES, PUBLICATIONS AND REPORTS INDEX.

Illustrations on following pages \* show the new Visual Identification markings of four typical Coast Guard aircraft. Bear in mind that designs and markings may change. For details refer to the drawing of the specific type aircraft. See AVIATION TECH. NOTE 2-68 for general information.

---

\*Now in preparation as Amendment -2.

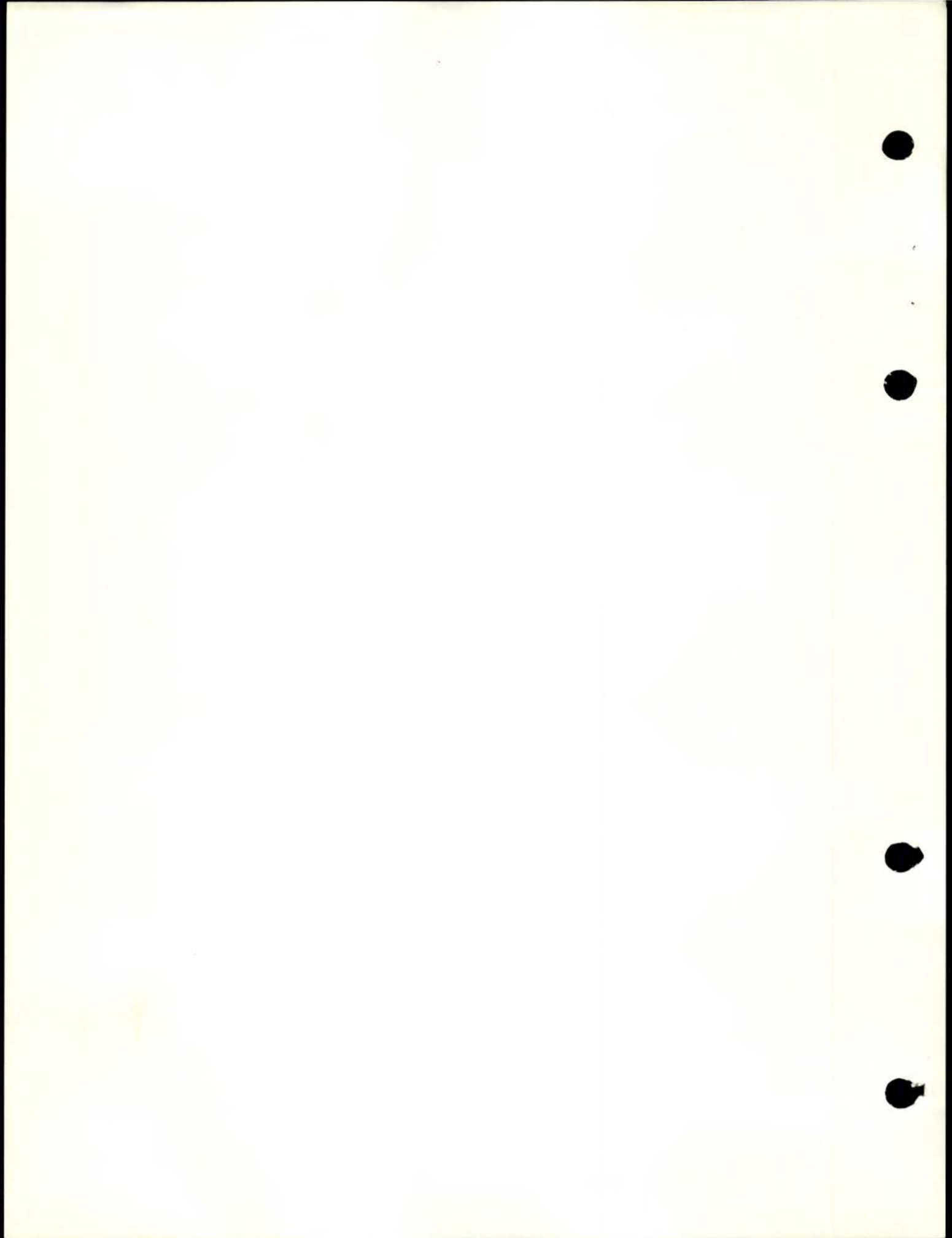

VC-4A AIRCRAFT

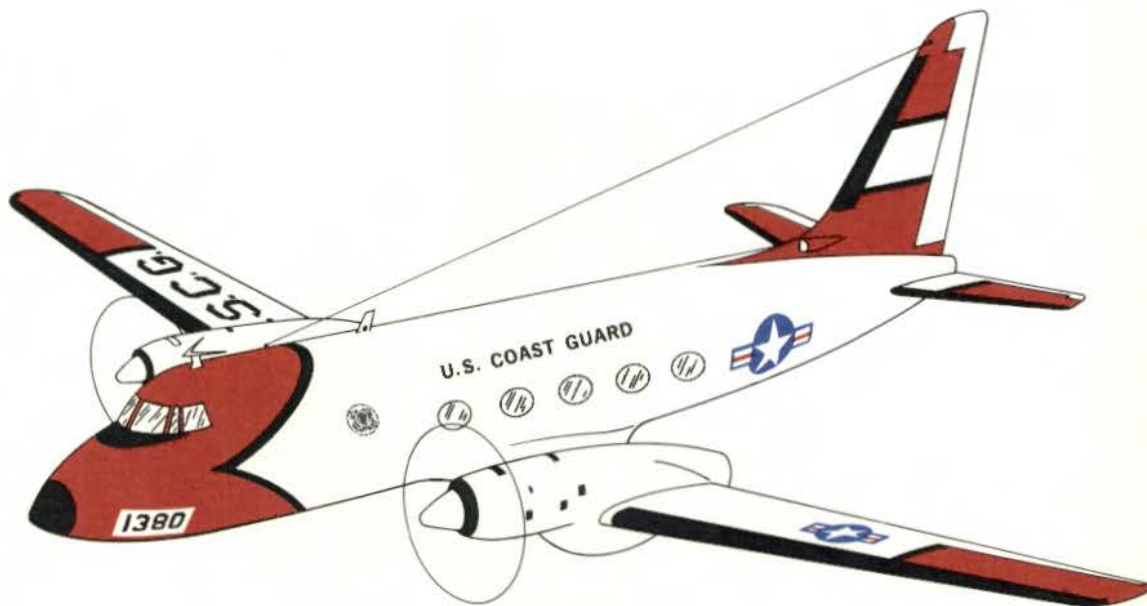

HC-130B AIRCRAFT

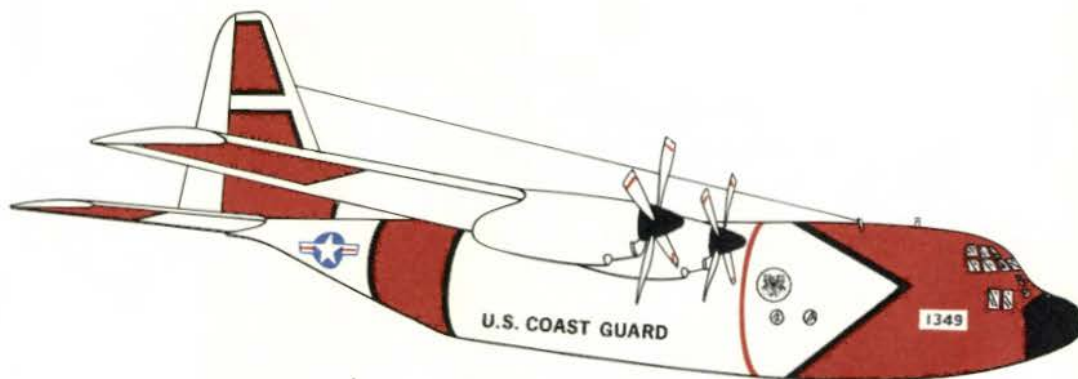



HU-16E AIRCRAFT

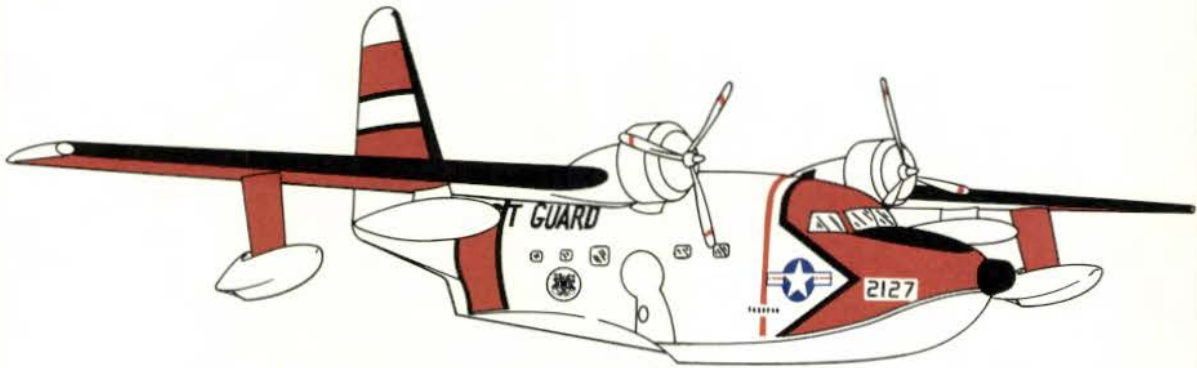

HH-52A AIRCRAFT







## SECTION 3-16, SAFETY COLOR CODE

The Coast Guard Safety Color Code contained herein follows that of the American Standards Association, National Safety Council and U.S. Navy Safety Color Codes, modified as necessary for application to the Coast Guard. Briefly, red signifies damage control and fire protection equipment; yellow indicates striking and falling hazards and also flammable liquid and gas storage; orange indicates cutting, crushing and shocking hazards; green is used for first aid facilities and equipment; blue for identification of controllers and switch boxes. The Safety Color Code does not apply to vessels.

### 3-16-1, COAST GUARD SAFETY RULES AND REGULATIONS

Careful safety practice is mandatory throughout the Coast Guard. The protection and preservation of human life and limb are of utmost importance. Safety must be accepted as a duty prescribed by strict rules and regulations, but in addition good safety should become an everyday habit.

There are many hazards associated with surface preparation and painting, such as

falling, the danger of fire and fumes, skin infections, all of which demand constant attention. There are still more hazards exposed aboard ship or encountered on shore. While this present Section relates to shore units mainly, general and specific safety requirements and practices have been presented, as applicable, in the various Chapters, Sections and Articles of this Manual. It is herewith suggested that these references be consulted for an over-all review of the safety program operative throughout the Coast Guard.

Article 1-2-4, The Need for Safety

Article 1-3-17, Hazardous Paint Materials

Article 1-4-2, Fire Hazards in Paint Storage and Mixing

Article 1-4-3, Paint Storage at Shore Stations

Article 1-4-4, Shipboard Storage of Paints

Article 1-5-8, Safety Precautions in Abrasive Cleaning

Article 1-7-7, Skin Irritations Due to Painting



### 3-16-2

Article 1-9-6, Safety Precautions for Spray Painting—General  
Article 1-9-7, Special Precautions for Interior Painting  
Article 1-9-8, Fire and Explosion Data on Organic Solvents and Diluents Pertaining to Organic Coatings  
Article 1-11-5, Scaffolding  
Article 3-17-4, Use of Safety Markings (Machinery)  
Article 3-20-2, Safety and Warning Signs  
Article 3-21-4, Prescribed Code (Safety Helmets)  
Article 3-23-6, Radiation Hazards  
Article 3-23-7, Canisters (Gas Masks)

#### 3-16-2, USE OF RED

No. 13 Fire Red is standard for the identification of damage control and fire protection equipment. Its use for any other purposes, such as to mark points of danger or flammable liquid containers shall be discontinued.

No. 13 Fire Red shall be used for fire sheds, fire hydrants, fire alarm boxes, outside hose connections to standpipes and sprinkler lines. On the interiors of buildings it shall be applied to fire carts, hose connections and fire main valves. In painting fire main valves, the valve body, bonnet and handle shall be painted. Valve stems and threads on the valve body shall not be painted. Sprinkler heads and fusible links shall not be painted.

Areas of No. 13 Fire Red shall be painted behind fire fighting equipment on walls and columns. In order to facilitate location from a distance, 12-in. (or larger) bands or squares of red shall be applied directly above the equipment and about 12 ft. from the floor. Such panels should be fully visible at a distance of 25 ft.

Where extinguishers of different types are used, these shall be painted red (with the exception of brass or copper containers) and appropriately lettered in black or white: CO<sub>2</sub>, FOAM, CARBON DIOXIDE, SODA ACID, DRY CHEMICAL, etc.

To relate type of extinguisher to class of fire, further symbols and color designations are recommended, as described and illustrated

Symbol for Class A Fires  
No. 16 Bright Green  
Federal 14260



Symbol for Class B Fires  
No. 13 Fire Red  
Federal 11105



Symbol for Class C Fires  
No. 29 Bright Blue  
Federal 15123



Symbol for Class D Fires  
No. 14 Brilliant Yellow  
Federal 13538



herewith. Where red panels are located 12 ft. or more above extinguishers, further markings may be appended thereto. The symbols may be approximately 8, 10, or 12 in. in size.

For Class A fires (wood, paper, rubbish, deep-seated fires), the symbol is a green triangle containing the letter A in white. Applicable extinguishers are soda acid, foam and multi-purpose dry chemical.

For Class B fires (oil, gasoline and other flammable liquids which do not mix with water), the symbol is a red square containing the letter B in white. Applicable extinguishers are carbon dioxide, vaporizing liquid, foam and dry chemical. (Foam, however, is not to be used to extinguish fires in alcohol or acetone.)

For Class C fires (electrical equipment), the symbol is a blue circle containing the letter C in white. Applicable extinguishers are carbon dioxide, vaporizing liquid and dry chemical.

For Class D fires (metal), the symbol is a yellow five-pointed star containing the letter D in black. Here fire of high intensity may occur in metals such as titanium, magnesium, zirconium, sodium, potassium, etc. Ignition is usually the result of friction (grinding), exposure to fire or high heat, and in some cases exposure to moisture. Normal extinguishing agents should not be used for

Class D fires. Approved extinguishing agents are available in dry powder form which may be applied with a scoop or shovel or by means of an extinguisher designed for dry powders.

Valuable data on fire protection will be found in booklet NFPA No. 10, Portable Fire Extinguishers (1963). This may be secured from the National Fire Protection Association, 60 Batterymarch Street, Boston, Mass. 02110.

Although tradition has established red as a color for containers of gasoline, coal tar naphtha, kerosene, alcohol and solvents, this use of the color is obviously wrong because of confusion with fire protection devices. Such containers shall be refinished in No. 14 Brilliant Yellow and lettered in black to indicate contents.

### 3-16-3, USE OF YELLOW

No. 14 Brilliant Yellow is the accepted standard to mark strike-against, stumbling and falling hazards. Where suitable, alternate bands of black and No. 14 Brilliant Yellow shall be used. Thus yellow (or black and yellow) shall be applied to guard railings, curbing, the edges of platforms and pits, crane beams, pulleys, blocks and hooks, portable ladders, skids, hand trucks. Large overhead crane beams in shops, however, may be No. 19 Light Gray, with No. 14 Brilliant Yellow applied to the crane cab and to pulleys and hooks. Yellow is also desirable for materials handling equipment, small trucks, obstructions, dead ends, barricades, bumper plates on vehicles, the ends of tall jib, wall or automotive cranes.

On stairways a 4-in. band of No. 14 Brilliant Yellow shall be applied immediately under the tread on top and bottom risers.

(As noted in Article 3-7-1(I), No. 14 Brilliant Yellow is applicable to bulldozers, tractors, mules, ground maintenance and control equipment on airfields. No. 13 Fire Red is applicable to crash and rescue trucks.)

### 3-16-4, USE OF ORANGE

No. 18 International Orange is standard for hazards which are likely to cut, crush, burn or shock personnel. It shall be applied on or near the dangerous parts, gears, shears, rollers of saws, planers, brakes, rolling and

crushing devices, forming presses, punch presses, riveting machines. It is desirable to use orange on the under side of guards over belts or gears in order to signal against carelessness by exposing a gaudy color to the eye. The exteriors of such guards shall be gray.

No. 18 International Orange shall be used for guards around hot pipes and exposed electrical wires and connections. Overhead electric wires or rails for conveying and hoisting equipment often present a hazard which should be conspicuously marked on adjacent beams, covers or supports. The inside of switch box doors and covers shall be painted No. 18 International Orange to reveal a vivid color and encourage the proper closing of panel doors at all times.

### 3-16-5, USE OF BLUE

This color shall be used in industrial areas for switch and fuse boxes, control panels, off-and-on control boxes on machinery. In personnel facilities and offices, however, electrical control panels may be in the wall color. In all instances, the *inside* areas of such boxes should be painted No. 18 International Orange.

Blue is also applicable to electrical control mechanisms, electric shore tie connections, welding gear, the control boxes of hoists, winches, cranes. Used as a background for a sign, with the lettering OUT OF SERVICE, good safety practice makes its use mandatory in marking equipment shut down for repair: elevators, boilers, kilns, ovens, tanks, pits, scaffolding. The blue sign shall, wherever possible, be placed over controls and is not to be removed except by the person who has put it in place.

### 3-16-6, USE OF GREEN

No. 16 Bright Green shall be used for the identification of first aid equipment. It shall be painted on first aid and medicine cabinets, stretcher boxes, cabinets for gas masks, safety showers and for all signs relating to first aid and safety. To facilitate the location of safety devices, 12-in. green crosses shall be painted about 12 ft. from the floor on walls and columns to be clearly seen from a distance.

3-16-8

### 3-16-7, AISLE MARKS

It is good practice to use aisle marks and lines to indicate traffic lines, parking locations and storage areas. White shall be used where floors are dark, and black where floors are light. Lines and marks around hazards or along pit and platform edges shall be No. 14 Brilliant Yellow. This practice will help to avoid accidents.

It is important to understand that safety colors are for functional purposes only, not for decoration. Particularly in industrial areas, their use shall hold practical meaning and be seen by personnel solely where the distraction of color will provide a safeguard.

For the application of safety colors to machinery, see Article 3-17-4.

### 3-16-8, CRANE CONTROLS AND HOOKS

For standardization, crane control handles, corresponding hooks and lower blocks shall be painted according to the following color scheme, modified to individual installations:

Red—Port Vang  
Green—Starboard Vang  
White—Topping Lift  
Yellow—Main Purchase  
Orange—Relief Purchase

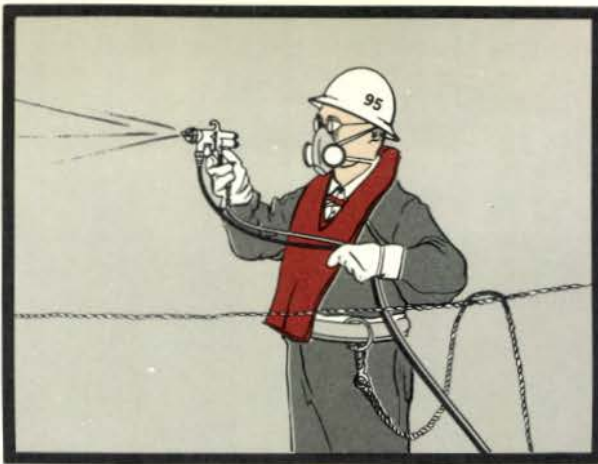

Safety requires protection as to helmet, gloves, respirator, life belt, life jacket (over water).

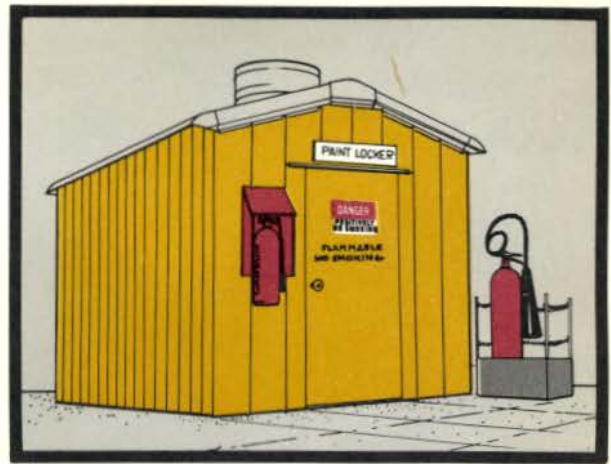

Paint lockers should be No. 14 Brilliant Yellow, with No. 13 Fire Red for fire protection.

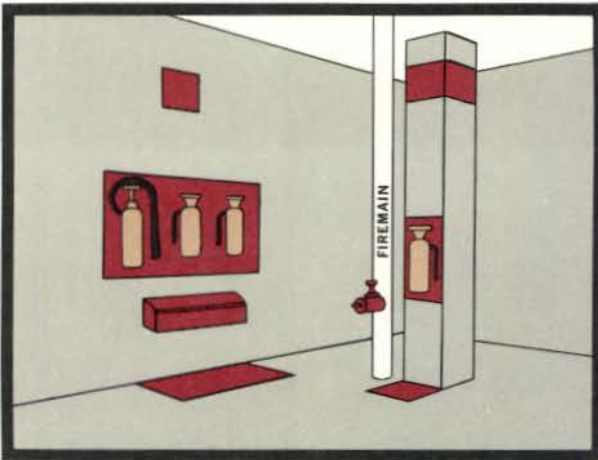

Areas of No. 13 Fire Red shall be placed on walls and columns to aid the location of fire extinguishers.

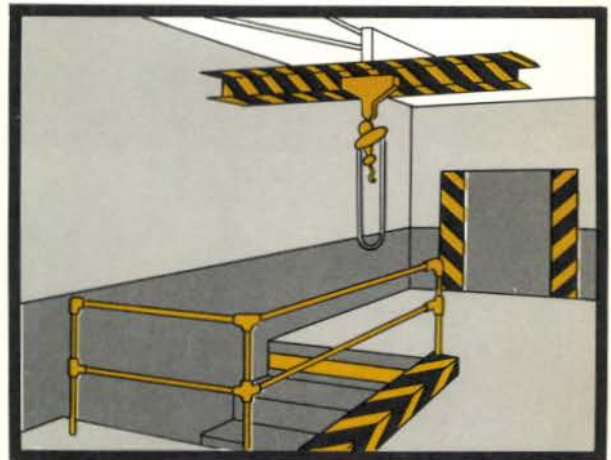

No. 14 Brilliant Yellow shall be used for obstructions, guard railings, curbing, projections and such hazards.

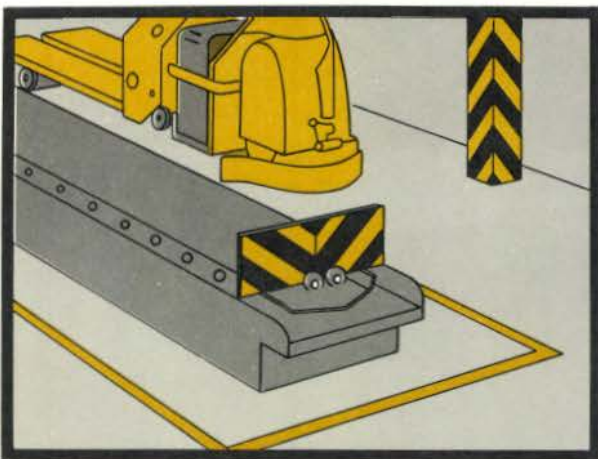

Moving parts, projections, obstructions shall be clearly marked No. 14 Brilliant Yellow and black for ideal safety.

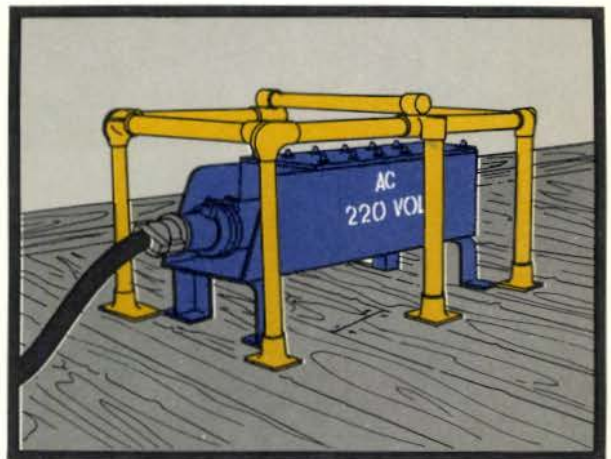

Use No. 29 Bright Blue for shore tie connections, welding and electrical equipment in general.



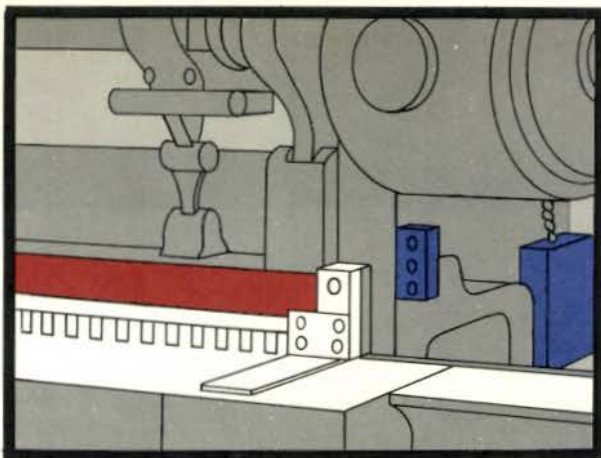

No. 18 International Orange shall be applied on or near the hazardous parts of shears, knives, rollers, gears.

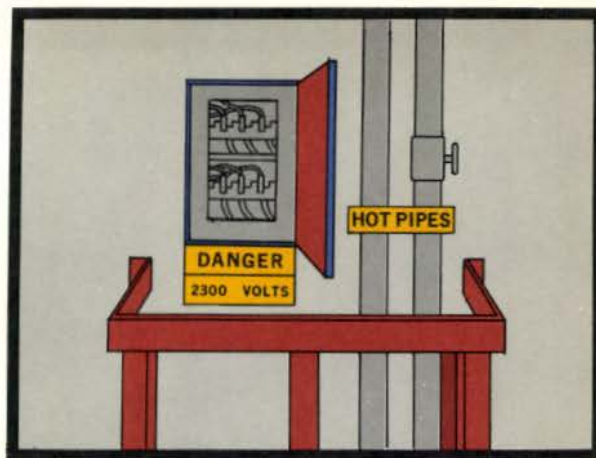

Orange should mark hot pipes, exposed electrical connections, and all cutting, crushing or shocking dangers.

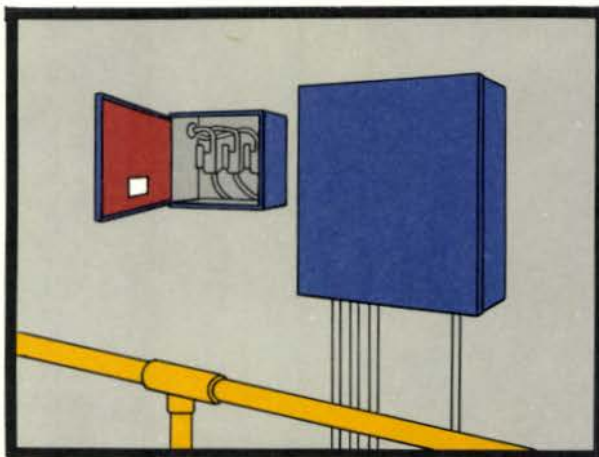

Shop switch boxes and control panels should be No. 29 Bright Blue, with No. 18 International Orange inside doors.

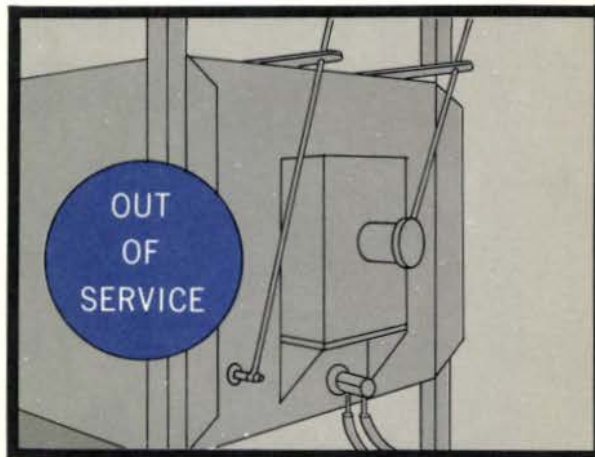

Out of service signs, in blue, shall be used for equipment, boilers, elevators, tanks, etc. shut down for repair.

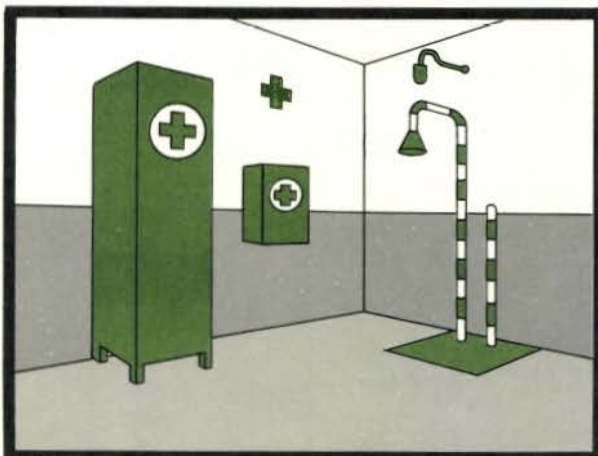

No. 16 Bright Green is standard to mark first aid equipment and devices, safety showers, stretcher boxes.



Pier edges, bollards and cleats shall be No. 14 Brilliant Yellow if they constitute a hazard.





## SECTION 3-17, MACHINERY COLORS

The painting and finishing of Coast Guard machinery should follow simple principles. Two grays are recommended: No. 20 Medium Gray (Federal 16187) and No. 30 Equipment Gray (Federal 16376). Gray makes an ideal surface. It is easily cleaned and touched up. It is fair in the reflection of light and therefore helps to encourage good machine care and maintenance. Having a neutral tone that resembles the color of metal, it will present a good appearance where the finish itself may be worn away. Better than any decorative color, gray does not look unsightly where it may be chipped or soiled.

### 3-17-1, USE OF NO. 30 EQUIPMENT GRAY (FEDERAL 16376)

No. 30 Equipment Gray (Federal 16376), being a light tone of gray, is the preferred finish for precision tools and machinery. Its use is recommended where high standards are expected and where a light rather than medium or deep finish will contribute to superior workmanship. It is particularly appropriate for fine tool work, the machinery and equipment in precision machine shops, electronic shops, testing laboratories, emergency power plants and the like.

### 3-17-2, USE OF NO. 20 MEDIUM GRAY (FEDERAL 16187)

No. 20 Medium Gray, being a deeper and therefore more practical color than No. 30 Equipment Gray, may be accepted for more or less universal use in machine shops, carpenter shops, engine repair shops, erecting shops, boat repair shops, heat treating and plating shops, foundries, forge shops, power houses, engine rooms and compressor rooms. No. 20 Medium Gray may also be considered for engine blocks, frames and supports. Good practice would prescribe its use as an area under machinery on wood and concrete

floors to seal the surface, prevent oil absorption and make cleaning easy.

### 3-17-3, USE OF NO. 22 HIGH-LIGHT BUFF

It is permissible to paint machinery uniformly in No. 30 Equipment Gray or No. 20 Medium Gray. However, there is great advantage in adding No. 22 High-Light Buff to concentrate attention at important points and to reflect more light. Illustrations herewith show the use of the buff color on typical machinery. Normally the buff should be restricted to heads, chucks and surfaces at vital points and in the immediate field of view. It should not be used for decorative purposes, on machined steel surfaces not subject to painting, or on remote parts of a machine which are not significant in its operation. It is usually unnecessary on wheels or levers which a worker may operate while his attention is directed elsewhere.

### 3-17-4, USE OF SAFETY MARKINGS

No. 29 Bright Blue is prescribed for switch boxes and controls to aid identification and yet be free of distraction. No. 18 International Orange is to be used where cutting and crushing hazards are involved and for the dangerous parts of machines or energized equipment which may cut, crush, shock or otherwise cause injury. It should be painted on the guards over saws, along the edges of knives, shears and rollers. This color should also be applied with great care so that its meaning to personnel will be significant. A guard that completely encloses a hazard should, of course, be the same gray as the body of the machine. No. 14 Brilliant Yellow, or black and yellow striping, may be applied to projections, curbing and parts which constitute a strike-against or stumbling hazard. Also see Safety Color Code, Section 3-16.



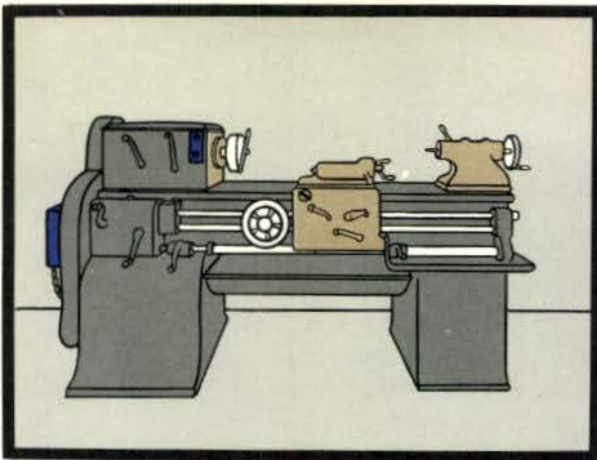

ENGINE LATHE

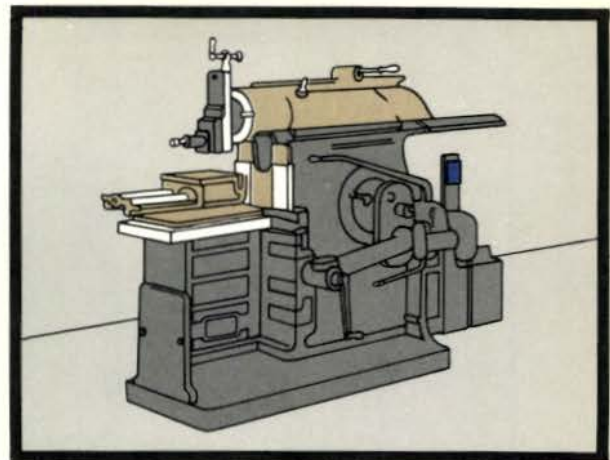

SHAPER

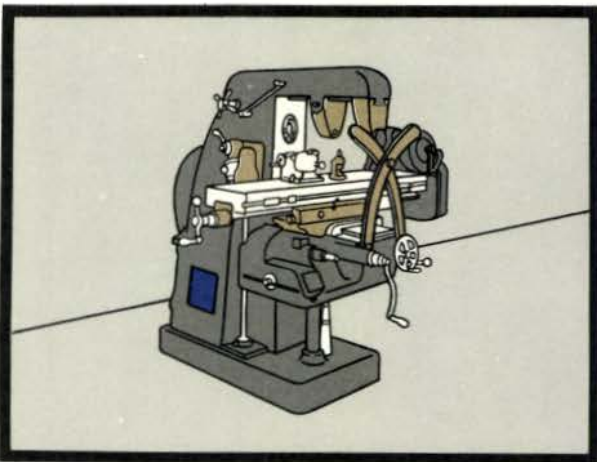

MILLING MACHINE

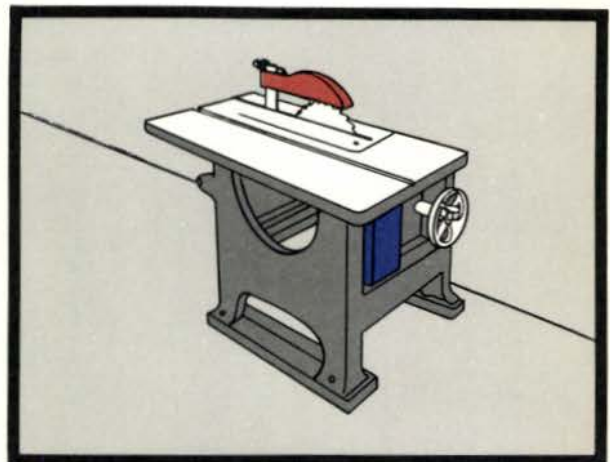

POWER SAW

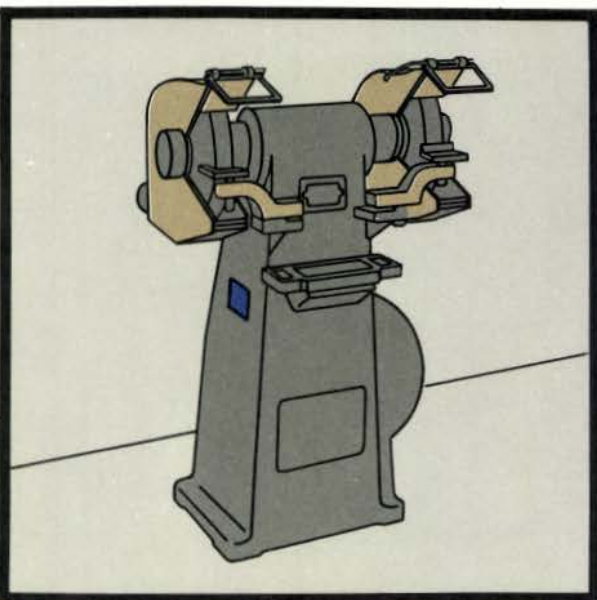

TOOL GRINDER

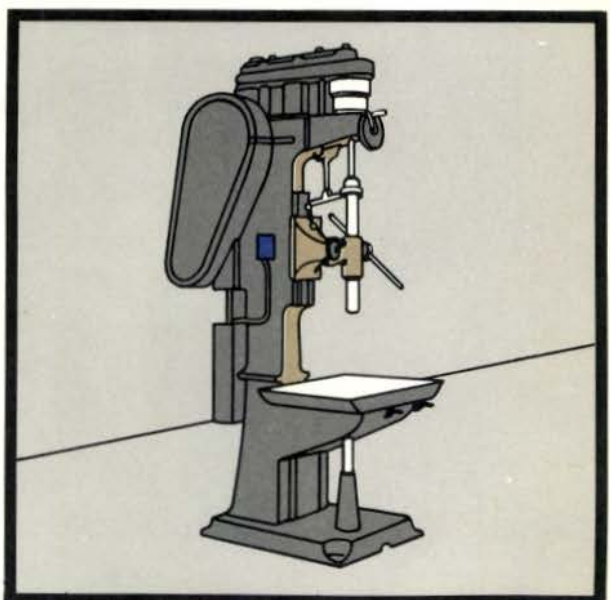

DRILL PRESS



## SECTION 3-18, COMPRESSED GAS CYLINDER IDENTIFICATION

### 3-18-1, COLORS TO BE USED

All compressed gas cylinders owned by the Coast Guard shall conform to the color code of MIL-STD-101.

The following colors which conform with MIL-STD-101, Color Code for Compressed Gas Cylinders and Pipelines, are to be used and lie within the tolerance limits of the code:

No. 14 Brilliant Yellow	No. 20 Medium Gray
No. 18 International Orange	No. 29 Bright Blue
No. 13 Fire Red	No. 33 Seal Brown
No. 16 Bright Green	No. 24 Spar
	White
	Black

### 3-18-2, TITLES

Exact identification of any material contained in a compressed gas cylinder is mandatory and shall be made only by means of the printed title. The title shall appear in two locations diametrically opposite and parallel to the longitudinal axis of the cylinder.

On cylinders 4 in. in diameter and larger the title shall be in approximately 2-in. high letters. On cylinders less than 4 in. in diameter they may be reduced in size.

Cylinders having a background color of yellow, orange, or spar shall have the title painted black. Cylinders having background colors of red, brown, black, blue, gray or green shall have the title painted white.

### 3-18-3, CYLINDER COLORS

The appearance on the body, top, or as a band on compressed gas cylinders of any of the following six colors shall provide a warning of danger from the hazard involved in handling the type of material contained in the cylinder.

<i>Class</i>	<i>Color</i>	<i>Class of materials</i>
1	Yellow	Flammable materials
2	Brown	Toxic and poisonous materials

3	Blue	Anesthetics and harmful materials
4	Green	Oxidizing materials
5	Gray	Physically dangerous materials
6	Red	Fire protection materials

The colors of the main portion of the body of cylinders are selected to group the materials conveniently and to simplify the code.

Extra cylinder color bands are to be used on the cylinder body. They serve as color warnings when yellow, brown, blue, green, or gray, and they provide color combinations to separate and distinguish cylinders for convenience in handling, storing, and shipping.

Cylinders commonly used in the Coast Guard are illustrated herewith.

The bottom and the lower portion of the cylinder body opposite the valve end may be used for commercial identification on cylinders not government owned. In this area, which shall not exceed one-sixth of the overall length of the cylinder, the use of a solid color other than the body color will not be permitted. Details on color arrangement are outlined in BuShips Manual, Section 23-24.

### 3-18-4, DECALCOMANIAS

Two decalcomanias may be applied on the shoulder of each cylinder and diametrically opposite and at right angles to the titles. They indicate the name of the gas, precautions for handling and use. The background color of the decalcomania may or may not correspond to the cylinder color. Details on decalcomanias are listed in BuShips Technical Manual, Section 23-27.

Shatterproof cylinders shall be stenciled with the phrase NON-SHAT longitudinally and 90° from titles. Letters shall be black or white and approximately 1 in. in size.

### 3-18-5, CYLINDER IDENTIFICATION CO<sub>2</sub> FIRE EXTINGUISHERS

When painting CO<sub>2</sub> cylinders ensure that

3-18-5

Navy and Interstate Commerce Commission serial numbers and test markings are not obliterated. When the indented figures and letters are not clearly legible, embedded paint and foreign matter should be carefully removed.

Two sets of markings shall appear on the shoulder of all cylinders:

(a) The ICC Serial Number, Navy Serial Number and Manufacturer's Marking.

(b) On the opposite side is the date of the hydrostatic test. The shatterproof cylinder is normally marked on this same side with NON-SHAT. If the words, NON-SHAT are not indented in the shoulder of the cylinders they should not be stenciled as such.

(c) Safety precautions for preparation of surface prior to painting are outlined in Bu-Ships Manual, Section 23-30.

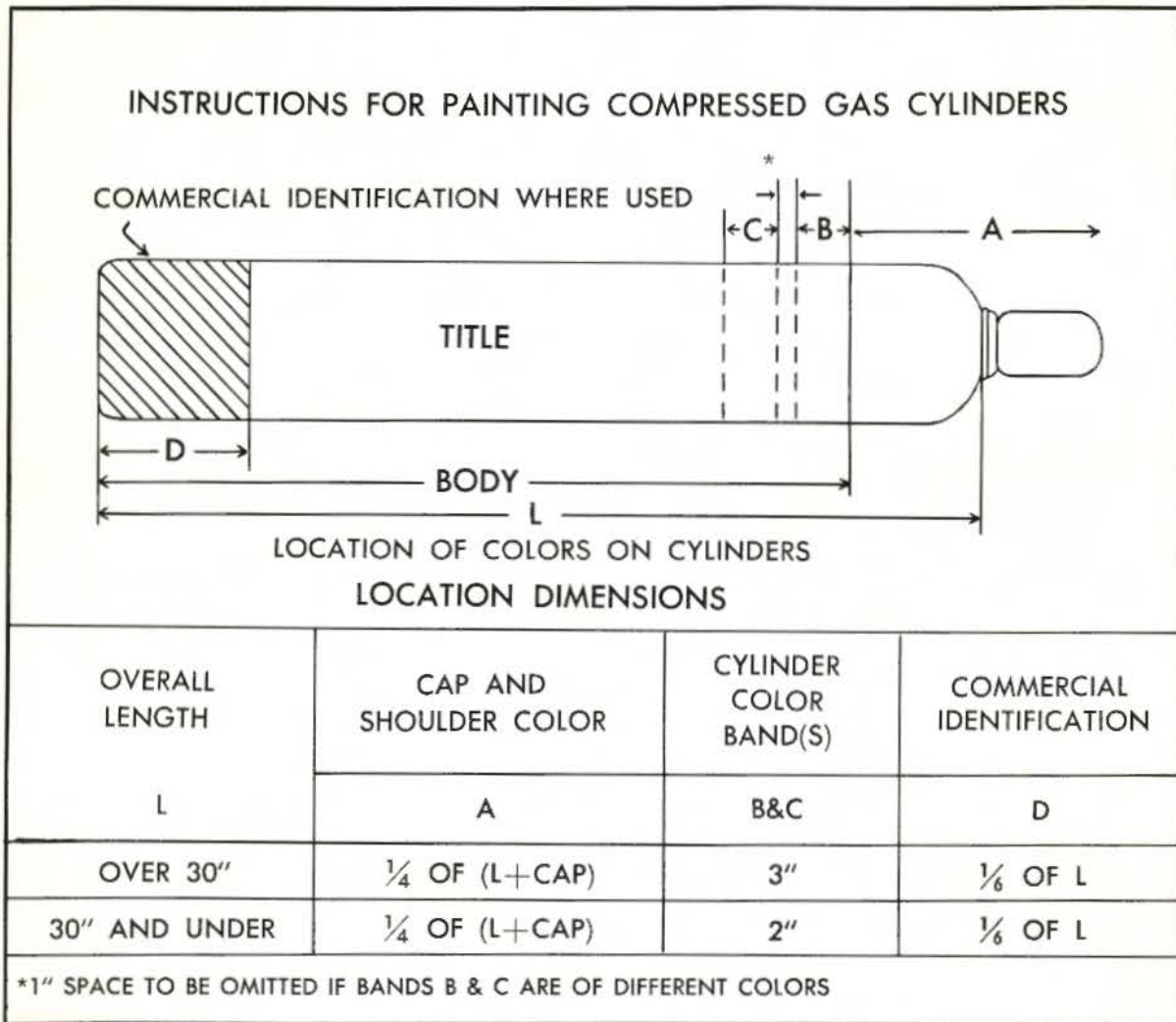

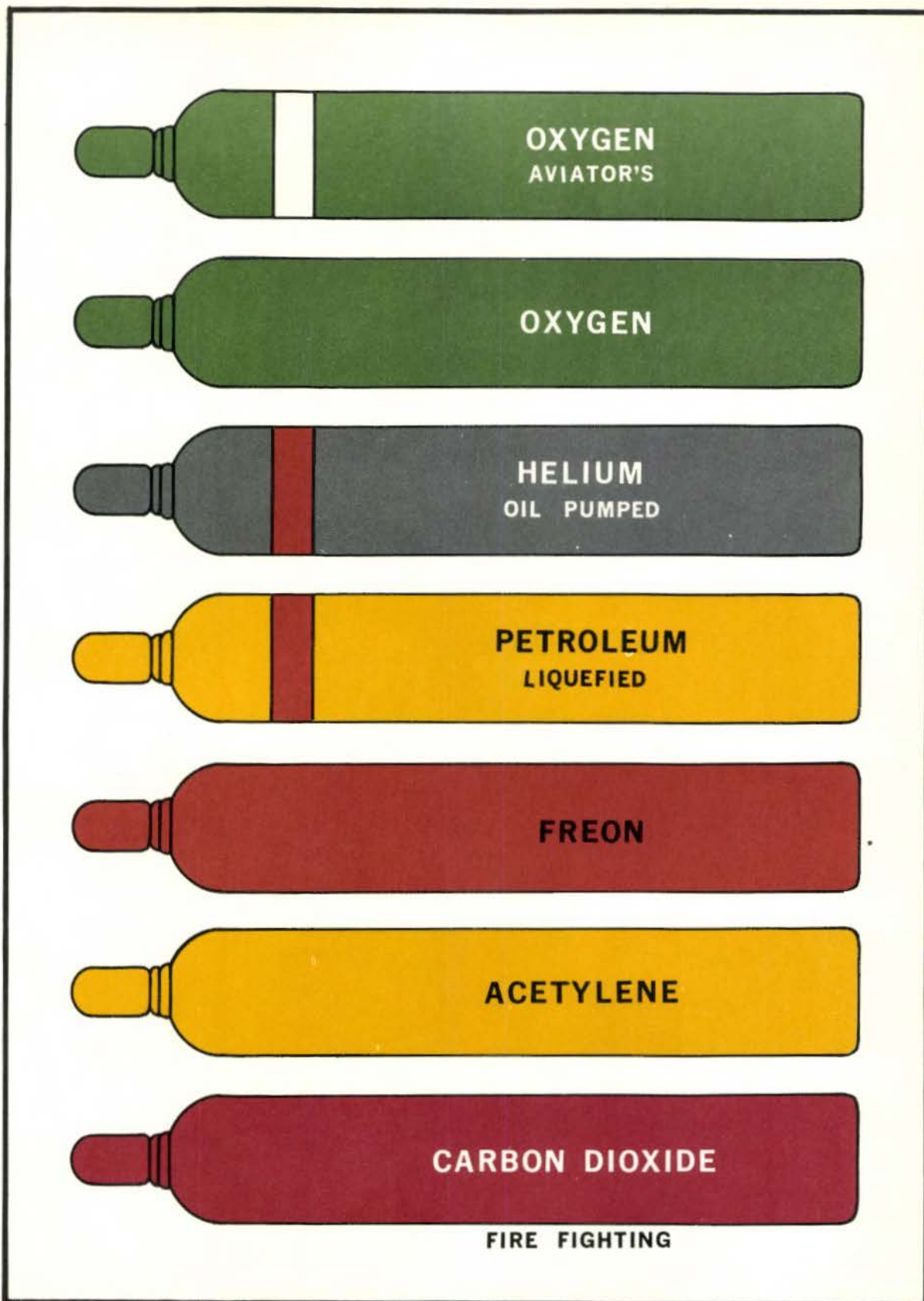





## SECTION 3-19, PIPING IDENTIFICATION

### 3-19-1, PIPING SYSTEM COLORS

Except as required below, all piping, including valve bodies, shall be painted to match adjacent bulkheads, walls, or overheads. Packing glands, valve stems, threads and similar working surfaces shall not be painted.

Gas and gasoline piping shall be painted No. 14 Brilliant Yellow throughout the piping system. Valves (except the threaded parts, valve stems and other working surfaces) shall be similarly painted.

Oxygen piping including valves (except the threaded parts, valve stems and other working surfaces) shall be No. 16 Bright Green.

Firemain valves, magazine sprinkler valves and fire hose connections (except threaded parts, valve stems and other working parts) shall be painted No. 13 Fire Red. The remainder of firemain and sprinkler main piping system shall be painted to match the surrounding areas. Aluminum sprinkler piping in

magazines shall not be painted. Steel valve handles shall be painted No. 30 Equipment Gray unless otherwise specified.

Identification of piping by means of color bands is not authorized for Coast Guard use.

### 3-19-2, PIPING SYSTEM MARKINGS

Exact identification of piping to indicate contents or type of service is mandatory and shall be made only by means of stencilled titles. Titles shall be applied with black lettering  $\frac{3}{4}$  in. high, except on pipe under  $1\frac{1}{2}$  in. O.D. on which the lettering shall be reduced proportionately to present a good appearance. Piping and tubing integral with machinery which are of such small sizes as to make lettering impractical need not be included in this requirement.

An arrow shall appear adjacent to each piping identification to indicate the normal direction(s) of flow of material in the system. Dimensions of the arrows shall be as shown herewith.

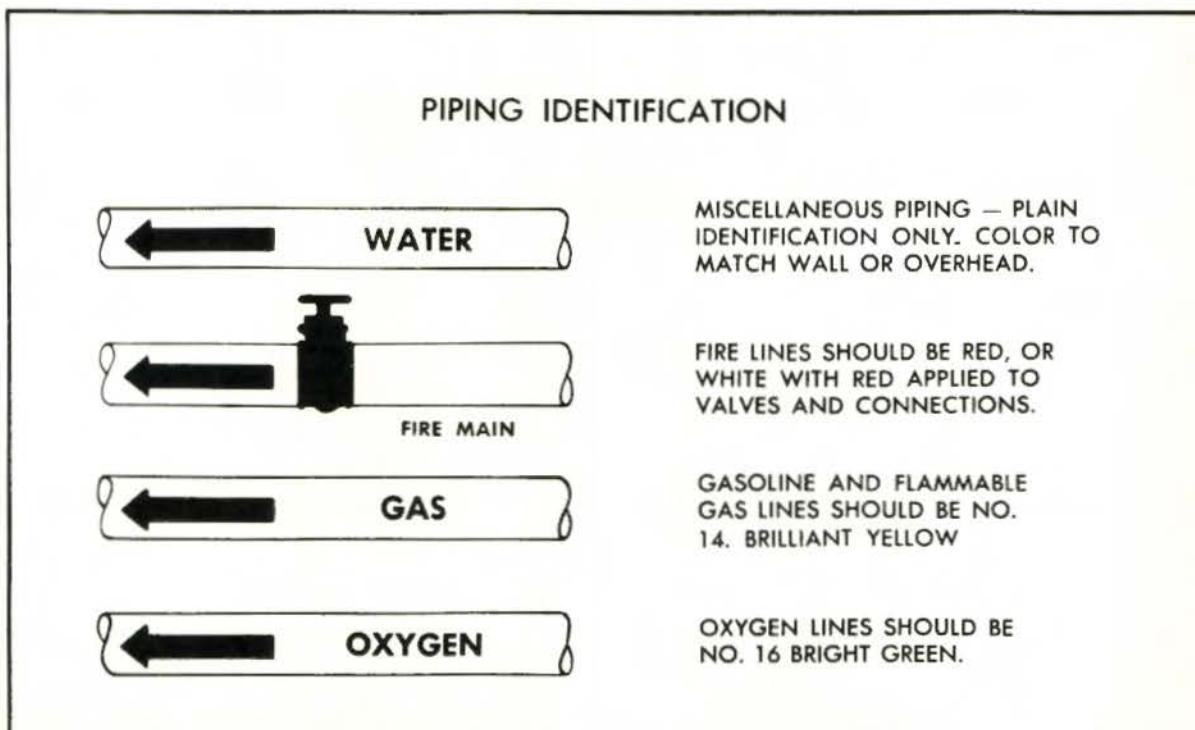

3-19-2

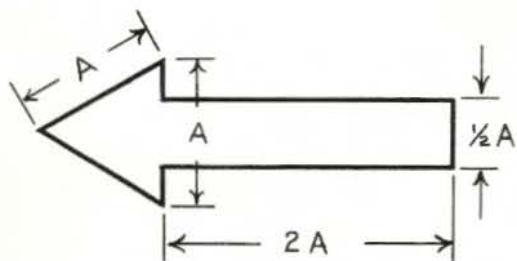

A=approximately  $\frac{3}{4}$  of outside diameter of pipe or covering. ( $1\frac{1}{2}$  in. maximum.)

It is recommended that where the view is unobstructed, titles be stencilled on the two lower quarters of the pipe or covering. Lettering in this position is unlikely to be obscured by dirt or mechanical damage. In any case titles shall be clearly visible from operating positions, especially those adjacent to control valves. Each pipe line shall be identified at least once in each compartment.

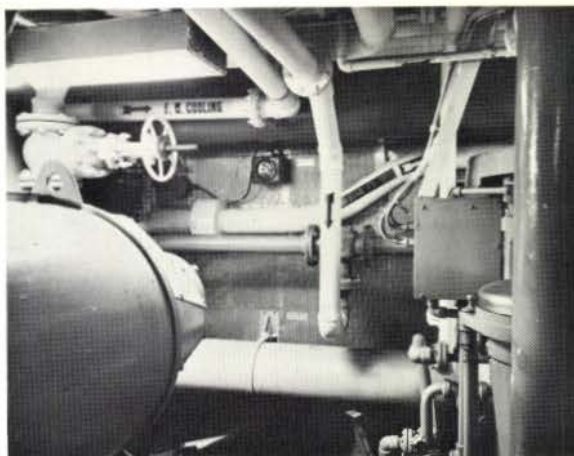

An example of shipboard piping identification to indicate contents and direction of flow.

## SECTION 3-20, SIGNS

### 3-20-1, HIGHWAY SIGNS

Highways signs, traffic control devices and pavement markings for any streets or roads under the jurisdiction of the Coast Guard shall follow the practices set forth in the following two publications. Such practices have been approved by the American Association of State Highway Officials and by the U.S. Department of Transportation, Bureau of Public Roads. ISM-2, Manual for Signing and Pavement Marking; Manual on Uniform Traffic Control Devices for Streets and Highways.

In general, STOP signs shall be octagonal in shape and lettered with white on No. 13 Fire Red. Railroad crossing signs are circular in shape and are black on yellow. Warning signs referring to hills, bumps, narrow roads, schools, and arrows indicating road turns, crossroads, etc., shall be diamond shaped and lettered with black on No. 14 Brilliant Yellow.

Regulatory and informational signs referring to speed limits, traffic direction, also guide signs and route markers, shall have black lettering on a white background. Parking prohibition signs shall be rectangular and have No. 13 Fire Red lettering on white; limited parking signs shall be the same shape and have No. 16 Bright Green lettering on white.

No. 14 Brilliant Yellow shall be used for curb marking where parking is prohibited. Yellow stripes are used as regulatory lines over which it is unsafe or illegal to travel. White road striping is used for traffic control, lane marking and stop lines. Road hazards shall be indicated with black and white stripes.

Insofar as practicable, highway guide signs shall be used for shore units that are located less than twenty miles off main highway. These signs shall be 6 in. x 36 in. in size. Lettering shall be of a height suitable for the legend

\* Formerly American Standards Association.

used and shall conform to the Standard Alphabet shown in Section 3-22, Letters and Numerals.

### 3-20-2, SAFETY AND WARNING SIGNS, STANDARD STOCK

A number of standard safety and warning signs are stocked at Coast Guard Supply Centers. These signs are manufactured to the specifications of the USA Standards Institute\* and are approved for Coast Guard use. Descriptions for a few of these signs are given below. For additional information on other types of safety signs, see CG-383.

#### (A) DANGER SIGNS

Danger signs shall have a white background. The word DANGER shall appear in white letters on a red oval inside a black rectangular panel. Sign wording shall be black letters on the white background. Danger signs shall be used only where an immediate hazard exists.

#### (B) CAUTION SIGNS

Caution signs shall have a yellow background. Word CAUTION shall appear in yellow letters on black rectangular panel. Sign wording shall be in black letters on the yellow background. Such signs shall be used only to warn against potential hazards or to caution against unsafe practices.

#### (C) DIRECTIONAL SIGNS

Directional signs shall have a white background. Arrow shall be in white on black panel. Wording in arrow or below panel shall be in black. Used to indicate way to locations: exits, fire escapes, stairways, first aid rooms, etc.

#### (D) INFORMATIONAL SIGNS

Informational signs shall be white lettering on No. 29 Bright Blue background. Other detail lettering may be black on white. These signs convey information not necessarily of a safety nature. Operating instructions and

signs which tend to avoid confusion and misunderstanding fall in this category.

#### (E) SAFETY INSTRUCTIONS SIGNS

Safety Instruction signs shall have a white or green background. If such words as THINK or SAFETY FIRST are used across the top, they should be in white letters on green rectangular panel. Other sign wording shall be in black letters on white background. These signs shall be used for general instructions and suggestions relative to safety measures.

A full description of these standard signs with the appropriate stock numbers and prices may be found in CG Cognizance Stock List, CG-383.. Check the current List for recent changes to sign stocks.

Locally made signs may follow the USA Standards Institute\* requirements given above or the below simplified descriptions which are a modification of the USA Standards Institute specifications.

#### 3-20-3, MISCELLANEOUS SIGNS

No. 13 Fire Red, with white lettering, shall be used for fire regulation signs, regulations regarding cigarettes and matches, warning signs as to explosives and flammable liquids.

No. 14 Brilliant Yellow, with black lettering, shall be used for danger and warning signs, such as KEEP AWAY, MEN WORKING, also for floor load and clearance signs and for all such cautioning instructions.

Simple directional signs used for traffic direction, office and department designations, names, titles, shall be black on white.

White on No. 29 Bright Blue (or No. 29

\* Formerly American Standards Association.

Bright Blue on White) may be used for signs not covered above. This would refer in general to operating instruction signs and to signs referring to miscellaneous current events.

All lettering applied by units on signs shall conform to the Coast Guard Standard Alphabet shown in Section 3-22, Letters and Numerals.

#### 3-20-4, SIGNS AND MARKERS FOR INACTIVE UNITS

Distinguishing Coast Guard signs and markers designed to catch the eye shall be removed from units which have been removed from OPFAC (CG-244). Standard warning notices should be posted on such property. These notices are available in vitreous enamel signs at Brooklyn, New York and Alameda Supply Centers as follows:

<i>Stock No.</i>	<i>Size—Inches</i>
(CG-9905-286-7010)	9x20
(CG-9905-286-7013)	10x8

#### *Wording*

#### STATION CLOSED

#### WARNING

All persons are warned not to trespass on this property or to injure or disturb any property of the U.S. Coast Guard. All violations will be prosecuted.

#### 3-20-5, IDENTIFICATION SIGNS

Standard signs for identification of Coast Guard Stations are fully described in COMDT-NOTE 5030. Typical signs are illustrated on the opposite page: they do not represent all of the signs which are authorized.

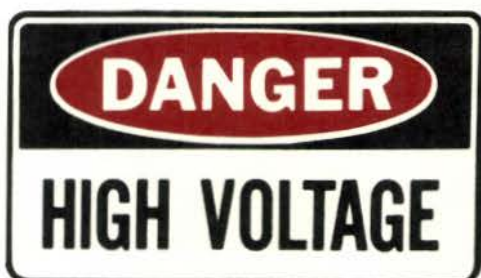



## SECTION 3-21, SAFETY HELMETS

### 3-21-1, PURPOSE

Safety helmets (hard hats) are required at all Coast Guard stations to provide protection for the head against injuries caused by falling and swinging objects, bumps, and electrical shock. The color symbols described shall apply primarily to industrial activities for the purpose of standardizing color and type of helmet and provide easily discernible identification of personnel within a shop or activity. Otherwise, U. S. Navy Uniform Regulations 1959 as amended for Coast Guard use shall apply.

### 3-21-2, IDENTIFICATION

Safety helmets shall be colored in accordance with specific instructions listed. In addition to that specified, personnel actively serving on a safety committee may have a 2 in. safety insignia on front center of crown. The safety insignia is a white cross set on a green circular background.

### 3-21-3, TYPE OF HELMET

Helmets shall be of the full brim type. Welders, burners, chippers, sand blasters and spray painters may wear the jockey-type hat, but only upon approval of a department chief or shop group master. Military personnel assigned to the Fire Department and security police are authorized to wear the jockey-type helmet.



### 3-21-4, PRESCRIBED CODE

The color code described herewith, and the identifying letters and numbers, shall be applied to safety helmets as noted.

#### (A) OFFICERS AND WARRANT OFFICERS

The helmet shall be all white. The appropriate commissioned or Warrant Officer's cap device in gold or bronze decalomania shall be placed on the front of the helmet. Below this insignia, the officer's rank and name, followed by the department or duty to which assigned, shall appear. Name shall be in 1/2 in. black letters, with rank and duty designation in 1/4 in. black letters. Medical and dental officers shall have a green cross on each side of crown. Helmets for visiting officers and those attached to ships undergoing repairs shall contain the word VISITOR in 1/2 in. black letters without the insignia. Example:

LCDR

A. F. KING

PROJECT COORDINATOR

#### (B) MASTERS AND FOREMEN

The helmet shall be all white. The Master's or Foreman's insignia (gold or bronze decalomania for masters, silver for foremen) shall be placed on the front of the helmet. Below this insignia, the name shall appear in 1/2



in. black letters with rating or shop in ¼ in. black letters.

(C) CHIEF QUARTERMEN AND QUARTERMEN

The helmet shall be all white with Chief Quartermen's or Quartermen's insignia (decalcomania) placed on the front of crown. Below this insignia, on the crown shall be placed the supervisor's name in ½ in. black letters, with rating in ¼ in. black letters. The shop number in 3 in. black numbers will be prominently displayed on each side of crown.

(D) LEADINGMEN AND SHOP PLANNERS

The helmet shall be all white with name in ½ in. black letters and rating in ¼ in. black letters placed on the front. The shop number in 3 in. black numbers will be prominently displayed on each side of crown.

(E) ALL OTHER SHOP PERSONNEL BELOW SUPERVISORY LEVEL, INCLUDING PUBLIC WORKS SHOPS

The helmet shall be all aluminum in color, except riggers whose helmets shall be solid No. 14 Brilliant Yellow. The shop number in 3 in. black numerals will be prominently displayed on each side of crown. For apprentices, a 2 in. high black letter A shall appear on the front of the crown.

(F) FIRE DEPARTMENT PERSONNEL

The helmet shall be No. 13 Fire Red. In the case of Chief Fire Marshal and Fire Marshals, title will be in front in ½ in. black letters.

(G) SAFETY OFFICE PERSONNEL

The helmet shall be No. 16 Bright Green with a 2 in. white cross prominently displayed on each side of crown. Name in ½ in. white letters and rating in ¼ in. white letters shall be placed in front of crown.

(H) MEDICAL DIVISION PERSONNEL

The helmet shall be white with a 2 in. cross prominently displayed on each side of the crown in No. 16 Bright Green.

(I) ALL SUPERVISORY CIVILIAN PERSONNEL OF INDUSTRIAL, ADMINISTRATIVE, SUPPLY,

COMPTROLLER AND PUBLIC WORKS DEPARTMENTS, AND INDUSTRIAL RELATIONS OFFICE

The helmet shall be white with the name of activity and title in ¼ in. black letters and name in ½ in. black letters on front of crown. Example:

PLANNING  
G. O. PLAN  
CHIEF PLANNER

(J) ALL CIVILIAN PERSONNEL BELOW SUPERVISORY LEVEL OF INDUSTRIAL, ADMINISTRATIVE, SUPPLY, COMPTROLLER AND PUBLIC WORKS DEPARTMENTS AND INDUSTRIAL RELATIONS OFFICE

The helmet shall be all aluminum in color, with department or shop number in 3 in. black numerals prominently displayed on each side of the crown.

(K) SECURITY POLICE

The helmet shall be white jockey-type with the following distinguishing markings:

(a) On each side of crown just above the brim, a 2 in. x 5 in. red horizontal band with pointed ends.

(b) On back of crown, just above the brim, a horizontal diamond shaped 2 in. x 8 in. red band.

(c) The words SECURITY POLICE in 1 in. black letters on front of crown just above brim.

(d) A small decal of the Coast Guard emblem, centered on front of crown, just above the words SECURITY POLICE.

NOTE: Red bands, under (a) and (b), are to be Scotchlite reflector material.

(L) ALL ENLISTED PERSONNEL, EXCEPT THOSE ASSIGNED TO FIRE DEPARTMENT, MEDICAL DIVISION, SAFETY OFFICE AND SECURITY DIVISION

The helmets shall be solid blue with identification or name of activity in ½ in. black letters on front of crown. Those in visiting ships shall be No. 29 Br with no lettering. Examples of a



## AERIAL IDENTIFICATION FIGURES

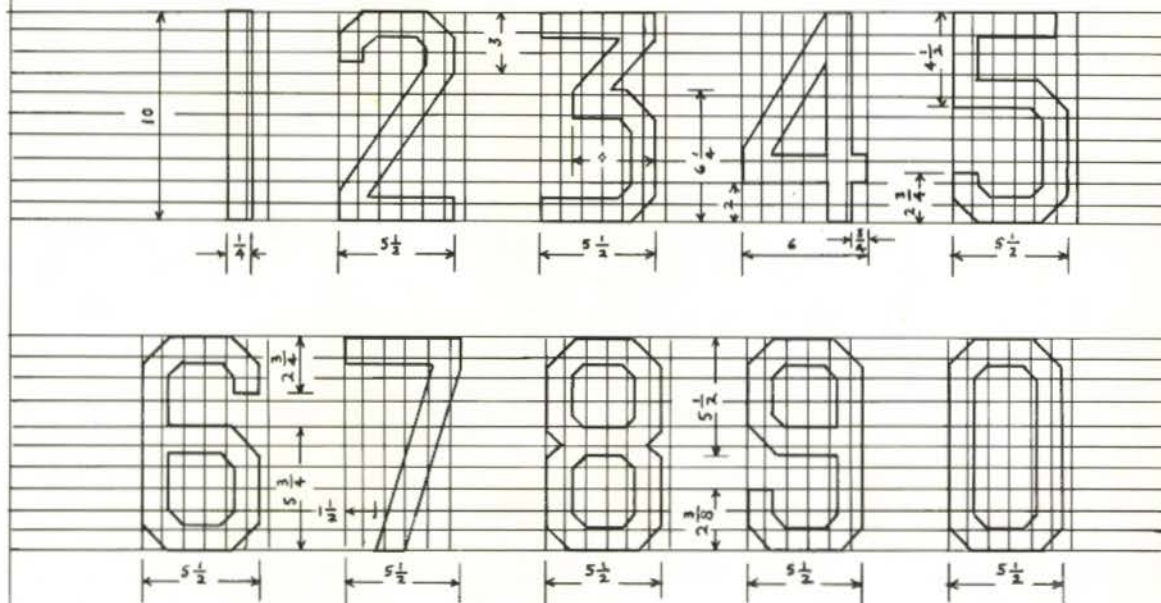

## AERIAL IDENTIFICATION LETTERS

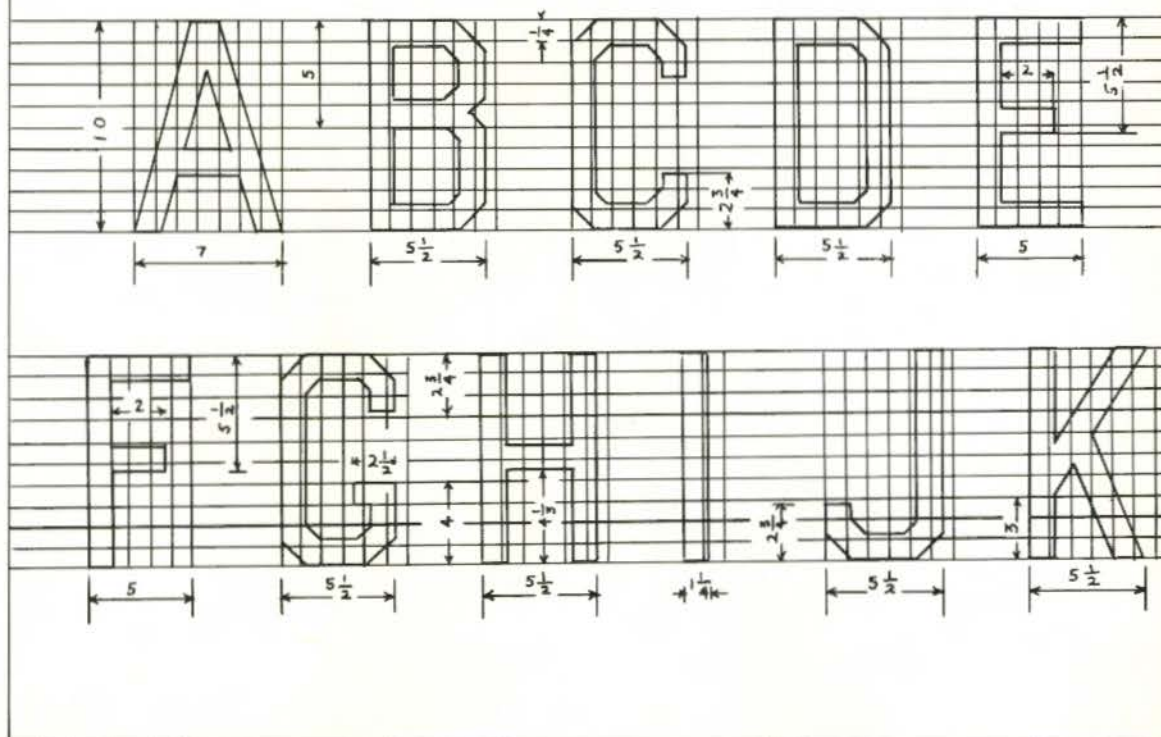

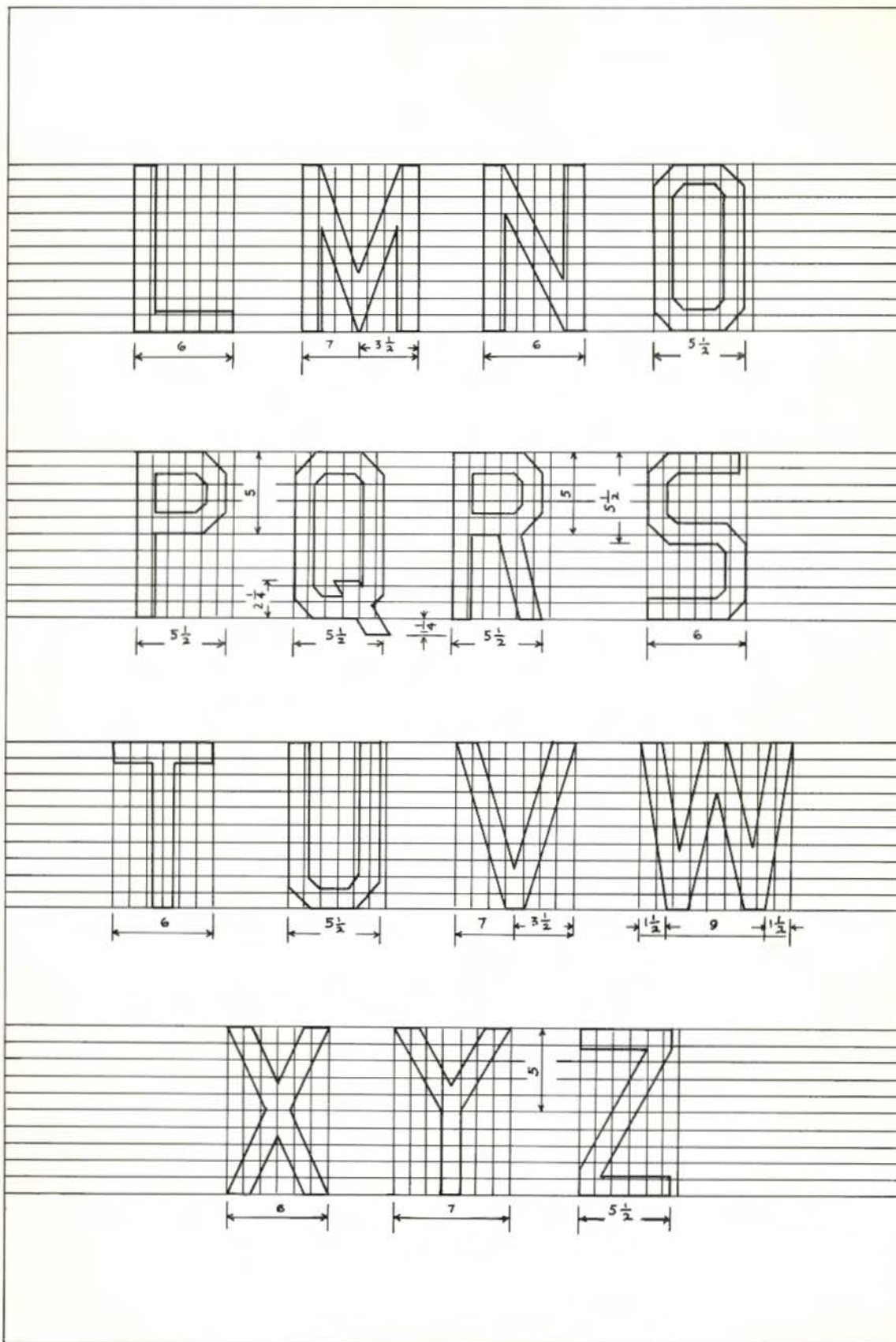

## SECTION 3-23, MISCELLANEOUS COLOR STANDARDS

The following references and publications all relating to the subject of color, are included here. Copies may be secured as noted. These standards should be studied, checked, and applied where necessary.

### 3-23-1, COLORS

Federal Standard No. 595, March 1, 1956, serves as a basis for all of the colors described and specified in this Manual. It is approved by the General Services Administration for the use of all Federal Agencies. This publication presents a collection of standard colors used by the various departments of the government. These standard colors, identified by 5-digit numbers, are classified into gloss, semi-gloss, and flat. For reference purposes, each color is approximately reproduced in the standard. For procurement, inspection and other color matching purposes, 3x5-inch color chips are issued as a supplement. Copies of the Standard may be purchased for \$2.25 each from the General Services Administration, Business Service Center, Region 3, Seventh & D Streets, S.W., Washington, D.C. 20024. The individual 3x5-inch color chips are available from the same source at 5 cents each or at \$15.00 for a set of 358 chips.

### 3-23-2, AIDS TO NAVIGATION REGULATIONS

Coast Guard publication CG-208 contains descriptions, illustrations and color standards of various aids to navigation, such as buoys, intercoastal waterway markings, lighting requirements for bridges, etc. This publication may be obtained from the Commandant (CHS).

### 3-23-3, AMMUNITION, MARKING OF

Current edition of Ordnance Pamphlet No. 4 Ammunition Afloat, Volumes I and II, gives general instructions for the handling of ammunition. References are made to colors for the marking of all types of projectiles, explosives, and boxes containing ammunition. Ordnance pamphlets are obtainable from the Commandant (OOR).

### 3-23-4, AIDS TO MARINE NAVIGATION OF THE UNITED STATES

Special booklet issued by Coast Guard, CG-193, describes buoyage maintained in the navigable waters of the United States and its possessions. It explains briefly the significance of the various colors of lighthouses and buoys, their markings and their shapes. This publication is obtainable from the Commandant (CHS).

### 3-23-5, LIGHT LIST, COAST GUARD

Light lists, published annually by the U. S. Coast Guard and obtainable from the Commandant (CHS), contain color requirements for light towers, structures, vessels and buoys maintained as aids to navigation.

### 3-23-6, RADIATION HAZARDS

Various publications are available on the application of color symbols to the hazards of radioactive materials. A purple symbol on a yellow base is to be used as a warning where radioactive material is stored. Shipping containers for radioactive materials take a variety of color symbols depending upon the classification of the material. For further information on this subject, write to Commandant (CHS).

### 3-23-7, CANISTERS

RBA Canisters: Approved standard canisters for Rescue Breathing Apparatus are painted gray and have instructions stencilled on the side with yellow paint. A yellow stripe approximately  $\frac{1}{2}$  in. by  $3\frac{1}{2}$  in. and additional instructions are also stencilled on the concave side of the approved canister.

Miscellaneous Canisters: A national standard is recognized for the marking of canisters used with gas masks. Colors for canisters indicate protection against the following:

### 3-23-9

White	Low concentrations of acid gases such as chlorine, formic acid, hydrogen sulfide, nitrogen peroxide, sulfur dioxide, etc.
Black	Low concentrations of organic vapors such as aniline, benzene, toluene, gasoline, etc.
Green	Ammonia gas.
Blue	Carbon Monoxide.
Yellow	Combinations of organic and acid fumes.
Brown	Acid and organic vapors and ammonia.
Black and White stripes	Dust, smoke, and mists in combination with any of the foregoing gases.
Red	Mixtures of the foregoing gases in air.

The colors used in the Manual may be employed. For more detail and a description of materials to be used in canisters, reference

may be made to Respirators, Gas Masks, Hose Masks and Breathing Apparatus, Safe Practices Pamphlet No. 64, published by the National Safety Council, 425 N. Michigan Avenue, Chicago, Ill. 60611. Also refer to NAVEXOS P-422, Revised Ed. 1960, plus Change 1, June, 1962.

### 3-23-8, ELECTRIC CABLES, SHIPBOARD, MARKING OF

Standards have been set up for the coding of electrical cables used on ships. A description of the symbolism and application of the colors is given in the current issue of MIL-C-915; Cables, Electric (Shipboard use). This publication may be obtained from Naval Supply Depot, 5801 Tabor Street, Philadelphia, Pa. 19120.

### 3-23-9, ELECTRICAL INSULATION

Military Standard MIL-STD-104, 27 June 1951, describes light and dark limits for electrical insulation colors. This publication is obtainable from Navy Supply Depot, 5801 Tabor Street, Philadelphia, Pa. 19120.

## SECTION 3-24, COAST GUARD

## COLOR SPECIFICATIONS

The color standards shown on Charts I and II are for shade of color only, not for paint finish or paint quality. The tabulation below includes: Coast Guard numbers and designations; Federal Standard numbers as given in Federal Standard No. 595, 1 March 1956 (see Article 3-23-1; and average light reflectances. In the 5-digit numbering system used in Federal Standard No. 595 the first digit indicates the gloss of a color; 1-gloss; 2-semi-gloss; 3-lusterless. Where a color is used in more than one gloss range, the last

four digits will be the same. In the table below, the number for the most generally used gloss indicated. No color chip is presented for No. 34 Emblem Blue. The printed color shown on the cover of this Manual may be used as a standard. To avoid fading, keep the chips from excessive exposure to light.

The Federal numbers printed under the color chips refer to Standard No. 595. Sets of Coast Guard color chips in separate binders are available from each District Commander in limited quantities.

<i>Coast Guard Color</i>	<i>Federal Standard No. 595</i>	<i>Light Reflectance (%)</i>
1. LIGHT GREEN	24516	55
2. MEDIUM GREEN	24277	26
4. SOFT YELLOW	23695	63
6. IVORY	23711	63
7. CORAL	21433	32
9. PEARL GRAY	26440	50
11. SUN TAN	23613	58
12. SPRUCE GREEN	14159	14
13. FIRE RED	11105	8
14. BRILLIANT YELLOW	13538	53
16. BRIGHT GREEN	14260	21
18. INTERNATIONAL ORANGE	12197	16
19. LIGHT GRAY	16251	29
20. MEDIUM GRAY	16187	16
22. HIGH-LIGHT BUFF	13578	56
23. TURQUOISE	25299	25
24. SPAR	10371	35
25. BEACH SAND (PEACH)	12648	65
26. TILE RED	10076	5
29. BRIGHT BLUE	15123	10
30. EQUIPMENT GRAY	16376	41
31. DECK GREEN	24172	16
32. BLUE GRAY	16099	9
33. SEAL BROWN	10080	4
34. EMBLEM BLUE	—————	3



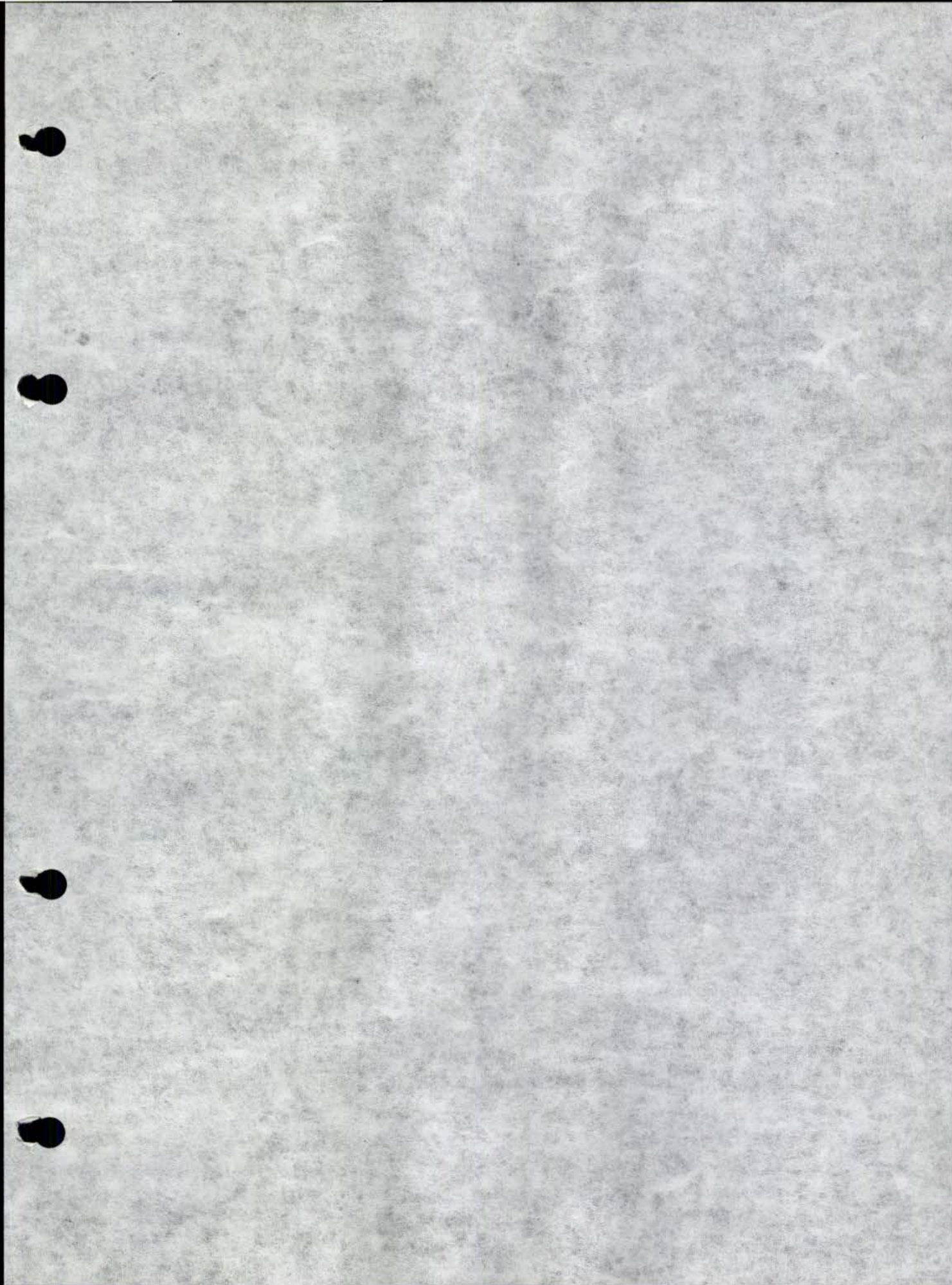

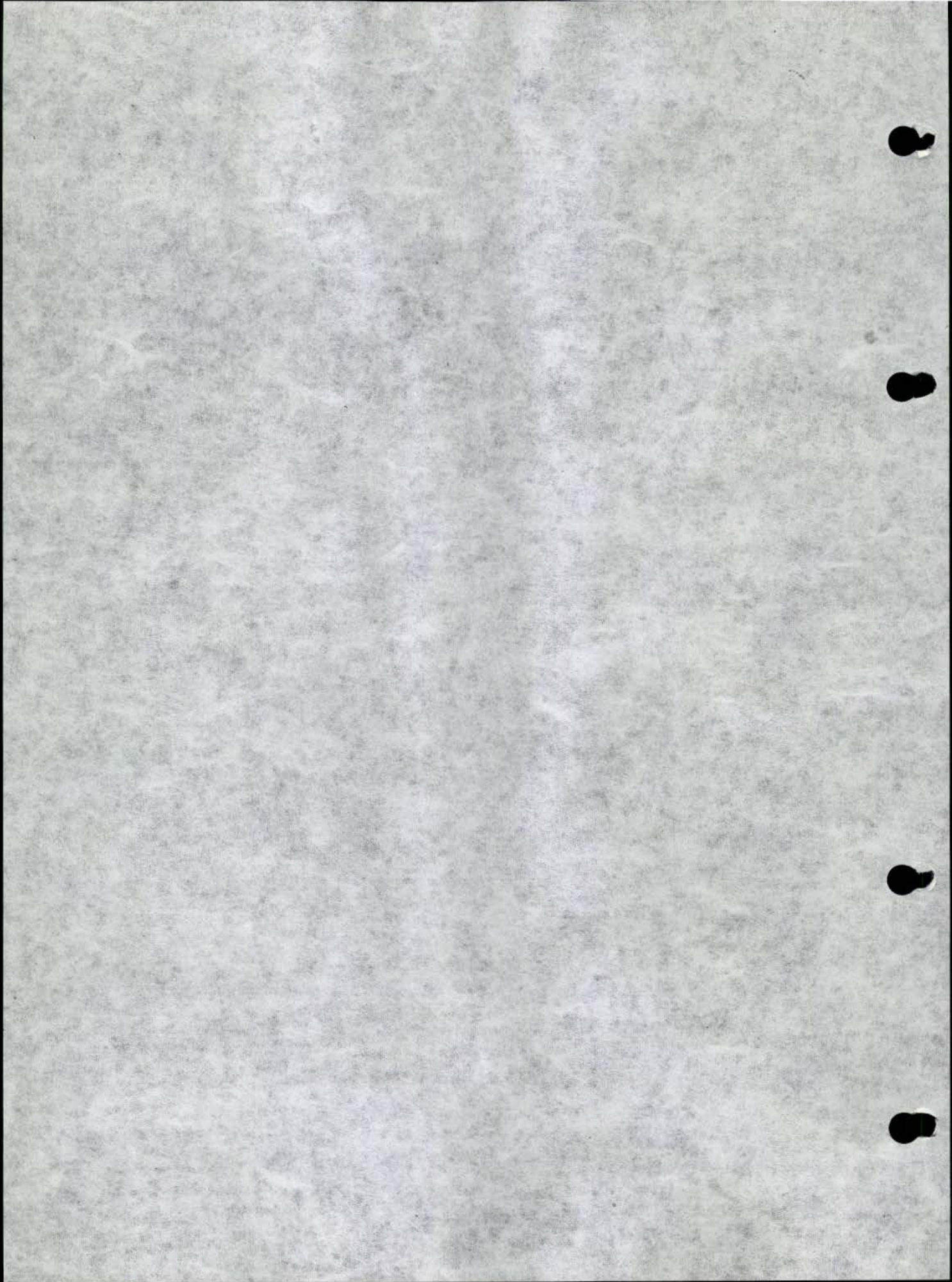





 <p>1. LIGHT GREEN Federal 24516</p>	 <p>2. MEDIUM GREEN Federal 24277</p>	 <p>4. SOFT YELLOW Federal 23695</p>
 <p>6. IVORY Federal 23711</p>	 <p>25. BEACH SAND Federal 12648</p>	 <p>7. CORAL Federal 21433</p>
 <p>9. PEARL GRAY Federal 26440</p>	 <p>23. TURQUOISE Federal 25299</p>	 <p>24. SPAR Federal 10371</p>
 <p>11. SUN TAN Federal 23613</p>	 <p>12. SPRUCE GREEN Federal 14159</p>	 <p>26. TILE RED Federal 10076</p>
<p style="text-align: center;"><b>COAST GUARD COLOR STANDARDS</b></p> <p style="text-align: center;">These samples are for shade only, not paint finish or paint quality</p>		

CHART I





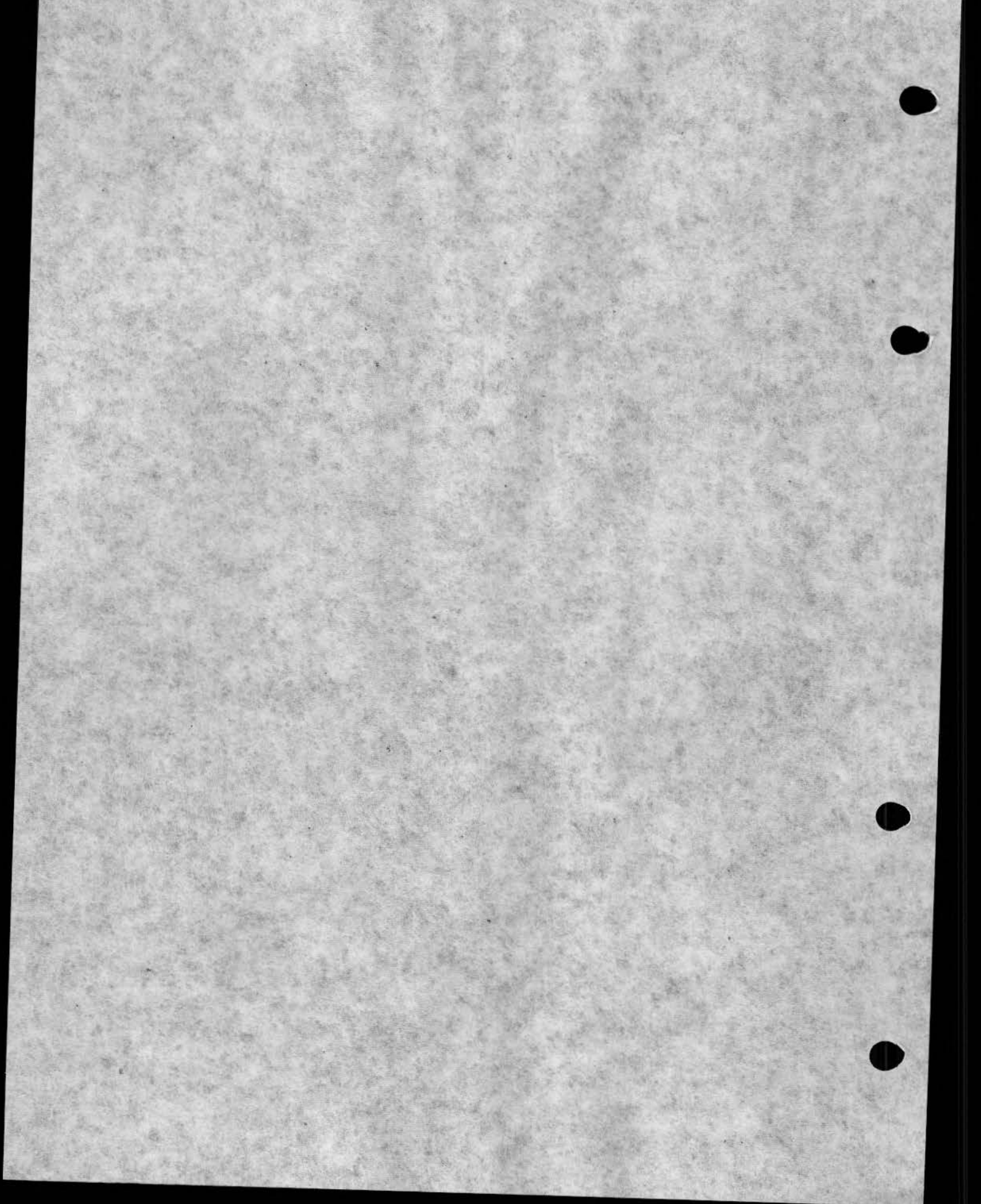

 <p>13. FIRE RED Federal 11105</p>	 <p>18. INTERNATIONAL ORANGE Federal 12197</p>	 <p>14. BRILLIANT YELLOW Federal 13538</p>
 <p>16. BRIGHT GREEN Federal 14260</p>	 <p>29. BRIGHT BLUE Federal 15123</p>	 <p>22. HIGH-LIGHT BUFF Federal 13578</p>
 <p>30. EQUIPMENT GRAY Federal 16376</p>	 <p>19. LIGHT GRAY Federal 16251</p>	 <p>20. MEDIUM GRAY Federal 16187</p>
 <p>31. DECK GREEN Federal 24172</p>	 <p>32. BLUE GRAY Federal 16099</p>	 <p>33. SEAL BROWN Federal 10080</p>
<p style="text-align: center;"><b>COAST GUARD COLOR STANDARDS</b></p> <p style="text-align: center;">These samples are for shade only, not paint finish or paint quality</p>		



# CHAPTER 4, MATERIALS

## TABLE OF CONTENTS

Section	Title
4-1,	INTRODUCTION: DESCRIPTION OF MATERIALS
4-2,	PRIMERS, FILLERS, SEALERS AND PRESERVATIVES
4-2-1,	PRETREATMENT-WASH PRIMER
4-2-2,	QUICK DRYING RED LEAD PRIMER (ALKYD VEHICLE)
4-2-3,	VINYL RED LEAD PRIMER
4-2-4,	SLOW DRYING RED LEAD PRIMER
4-2-5,	ZINC CHROMATE PRIMER, ALKYD TYPE
4-2-6,	ANTICORROSIVE SHIPBOTTOM PRIMER
4-2-7,	COPPER NAPHTHENATE WOOD PRESERVATIVE
4-2-8,	PASTE WOOD FILLER
4-2-9,	FLOOR SEALER
4-2-10,	EXTERIOR WOOD PRIMER
4-2-11,	INTERIOR WALL PRIMER-SEALERS
4-2-12,	INTERIOR WHITE ENAMEL UNDERCOAT
4-2-13,	THIN-FILM RUST PREVENTIVE
4-3,	PAINTS AND ENAMELS
4-3-1,	EXTERIOR OIL PAINT, GENERAL PURPOSE
4-3-2,	EXTERIOR OIL PAINT, FUME-RESISTANT
4-3-3,	EXTERIOR VINYL ALKYD ENAMEL
4-3-4,	EXTERIOR GLOSS ENAMEL
4-3-5,	ACRYLIC EMULSION PAINT FOR MASONRY
4-3-6,	TILE RED ROOF PAINT
4-3-7,	DECK AND FLOOR ENAMEL
4-3-8,	BASEMENT FLOOR PAINT
4-3-9,	EQUIPMENT ENAMEL
4-3-10,	INTERIOR GLOSS ENAMEL
4-3-11,	ENAMEL, FIRE-RETARDANT
4-3-12,	INTERIOR LATEX EMULSION PAINT (FLAT)
4-3-13,	STRIPING PAINT
4-3-14,	VINYL BOOT-TOPPING PAINT, BLACK
4-3-15,	COLD PLASTIC ANTIFOULING PAINT, FORMULA 146/50
4-3-16,	COLD PLASTIC ANTIFOULING PAINT, FORMULA 105
4-3-17,	VINYL ANTIFOULING PAINT
4-3-18,	POLYISOBUTYLENE ANTIFOULING PAINT
4-3-19,	RUBBER TIE-COAT FOR SONAR DOMES
4-3-20,	ALUMINUM PAINT, (READY-MIXED)
4-3-21,	HEAT-RESISTING ALUMINUM PAINT (READY-MIXED)
4-3-22,	TRAFFIC PAINT
4-3-23,	ZINC DUST PIGMENTED ENAMEL
4-3-24,	ANTISWEAT-COATING BINDER, FIRE-RETARDANT
4-3-25,	EXPANDED VERMICULITE

Section	Title
<b>4-4,</b>	<b>VARNISHES AND LACQUERS</b>
4-4-1,	SPAR VARNISH
4-4-2,	ELECTRICAL INSULATING VARNISH
4-4-3,	ASPHALT VARNISH
4-4-4,	SPRAYING LACQUER (FOR SHOP HELMETS)
4-4-5,	LACQUER, PRESSURIZED CONTAINER
4-4-6,	CLEAR BRUSHING LACQUER FOR BRIGHTWORK
4-4-7,	CLEAR ACRYLIC COATING
<b>4-5,</b>	<b>THINNERS</b>
4-5-1,	PAINT THINNER
4-5-2,	SYNTHETIC-ENAMEL THINNER
4-5-3,	VINYL PAINT THINNER
4-5-4,	LACQUER THINNER
4-5-5,	COAL TAR NAPHTHA
4-5-6,	BOILED LINSEED OIL
<b>4-6,</b>	<b>COMPOUNDS AND CEMENTS</b>
4-6-1,	WHITE PUTTY
4-6-2,	CALKING COMPOUND FOR WOODEN VESSELS
4-6-3,	CALKING COMPOUND FOR METAL SEAMS AND STEEL SASH
4-6-4,	PLASTIC CALKING COMPOUND
4-6-5,	PLASTIC WOOD
4-6-6,	MARINE GLUE
4-6-7,	SMOOTHING CEMENT FOR IRON OR STEEL
4-6-8,	HYDRAULIC CEMENT FOR IRON OR STEEL
<b>4-7,</b>	<b>MISCELLANEOUS MATERIALS</b>
4-7-1,	WET-SANDBLASTING CHEMICALS
4-7-2,	LIQUID FLOOR WAX
4-7-3,	AUTOMOBILE POLISH
4-7-4,	PAINT AND VARNISH REMOVER (ORGANIC SOLVENT TYPE)
4-7-5,	PAINT CLEANER
4-7-6,	METAL POLISH
<b>4-8,</b>	<b>HEAVY DUTY COATINGS</b>
4-8-1,	EPOXY PROTECTIVE COATINGS (GENERAL)
4-8-2,	EPOXY SYSTEMS, SPECIFIC
4-8-3,	COAL-TAR EPOXY COATINGS
4-8-4,	HEAVY BODY MASTIC COATING
4-8-5,	INORGANIC ZINC SILICATE COATINGS
<b>4-9,</b>	<b>PAINT SPRAY EQUIPMENT</b>
4-9-1,	TYPES OF EQUIPMENT, STANDARD STOCK
4-9-2,	HOT SPRAY, AIRLESS



## SECTION 4-1, INTRODUCTION:

### DESCRIPTION OF MATERIALS

Chapter 4 gives specific descriptions of each material and the information necessary to procure the correct materials for the job. Although the basic specification designations are listed, the latest revisions shall apply at time of procurement. This usually means the addition of letters to the number identifications herewith.

Materials are grouped into certain broad categories for quick reference: i.e., Primers, Fillers, Sealers, and Preservatives; Paints and Enamels; Varnishes and Lacquers; Thinners; Heavy Duty Coatings; Compounds and Cements; Miscellaneous Materials. Individual items are located by consulting the proper category in the Table of Contents. Where there is no material specified for a particular use, materials specified for similar uses will normally be found satisfactory.

Each item is described by a brief statement of its principal uses in the Coast Guard, general information on applying the paint, reference to all the Articles in the Manual wherein the use of the item is prescribed, and the information necessary to order the material. It should be noted that the name of the paint as used in the Manual, which is generally descriptive of its use in the Coast Guard, does not always correspond to the name of the paint as listed under Ordering Information. The reason for this is that the name given under Ordering Information is the name appearing in the Federal Supply Service Catalog or Coast Guard Catalog. These names are descriptive of the use of the material in the Federal Supply Service Catalog which is frequently different from the use of the material in the Coast Guard.

The information given under General Application Instructions should be read in conjunction with the appropriate articles listed under Specific Application Instructions in order to arrive at the number of coats of each material which comprise the coating system for the particular surface under consideration. Close attention must be given to the thinners

recommended in order to prevent adding a material which would be incompatible with the paint. In addition, the drying times listed are minimum times based on a temperature of 70° F; lower temperatures will require longer time to obtain thoroughly dried paint films.

It should be noted that some of the stock numbers are preceded by the letters CG whereas others are not. The prefix CG indicates that the material is available through Coast Guard Supply channels. Where a stock number does not carry the prefix CG, the material is available through both Coast Guard and GSA supply channels. Stock catalogues should be consulted for availability of other possible size containers.

The inclusion of an individual paint material in the Paint and Color Manual shall not be construed as a necessity for stocking the item at Supply Depots or individual units. Provisions for stocking the most widely used items have been made. Stocks of additional items will be established on a basis of actual requests and recommended for stocking in accordance with Comptroller Manual 3D, Chapter 4.

Most paints are fairly stable in storage with respect to the degree of fire hazard which they present. However, upon prolonged storage in the order of 2 or more years, there is a possibility that the degree of fire hazard presented by the material may increase through chemical reaction between paint and container, chemical reaction within the paint itself resulting in pressure build-up in the container, or through rusting of containers resulting in leaks. Another very real hazard in over-stocking is the fact that excessive quantities of combustible material are being stored.

All paints deteriorate to some extent in storage. The rate of deterioration is dependent on several factors. Therefore, no definite shelf life can be determined for a particular paint. However, every effort should be made to

apply paint within 1 year of manufacture. Many paint failures have been found to be directly or indirectly the result of prolonged

storage of the paint. Table I lists the approximate safe storage life of the most commonly used materials.

TABLE I  
APPROXIMATE SHELF LIFE  
PAINTS, VARNISHES,  
AND RELATED PRODUCTS

<i>Material</i>	<i>Months</i>		<i>Remarks</i>
	<i>40° F. to 90° F.</i>		
Drier, Paint	12		
Linseed Oil, Boiled or Raw	18		
Thinner, Dope and Lacquer (Cellulose-nitrate base for spraying)	24		
Thinner, Paint (mineral spirits)	24		
Thinner, Synthetic Enamel	24		
Enamels:			
Floor	12		
Gloss synthetic (interiors)	12		
Heat resisting	12		
High-gloss synthetic (outdoor sign painting)	12		
Lusterless	12		
Ready-mixed aluminum	12		
Semi-gloss air-drying	12		
Semi-gloss synthetic resin	12		
Fillers:			
Putty (wood-sash)	12		
Glazing Compound	18		
Filler, Wood, Paste:			
Filler for Wood	18		
Plastic Wood	18		
Lacquer:			
Spraying lacquer	12		See Footnote 2
Clear lacquer (pressurized can)	12		
Pigmented lacquer (pressurized can)	12		See Footnote 2
Paint, Oil:			
Alkyd-resin flat	18		
Aluminum (asphalt base)	24		
Aluminum (ready-mixed)	12		
Exterior with lead-zinc titanium base	12		
Fume-resistant	12		
International orange #12197	12		
Lusterless (non-penetrating)	12		
Red Lead (linseed oil base)	6		

<i>Material</i>	<i>Months 40° F. to 90° F.</i>	<i>Remarks</i>
Roof (mixed-pigment base)	18	
Wall	12	
Water-resistant concrete and masonry	18	
Paint, Heat-resisting	6	
Paint, Rubber:		
Rubber-base	12	See Footnote 1
Synthetic-latex (interior)	12	See Footnote 1
Paint, Traffic	6	
Paint, Latex Emulsion		
Resin-base (emulsified)	12	See Footnote 1
Pigment:		
In paint thinner, aluminum	12	
In paste form, lampblack	12	
Tinting paint for latex or emulsion	12	Keep at temperature to prevent freezing.
Primer Coating:		
For metal surfaces or all purpose (pressurized can)	9	See Footnotes 2 and 3
For walls, wood, or metal surfaces (non-pressurized container)	12	See Footnote 3
Remover, Paint:		
With paintable retardant	12	
With wax retardant	12	See Footnote 4
Roof Coating:		
Asphalt, Petroleum (bituminous asphalt and asphalt base)	12	6 months at 100° F. If held over 12 months contents may jell, settle, or cake and give false body. An emulsion type roof coating should not be stored in areas where temperatures are likely to approach freezing.
Sealer, Surface (tung-oil, lacquer, varnish)	18	
Shellac, Cut:		Do not agitate
Bleached (white) can	6	
(orange) glass container	12	
Stain:		
Floor, woodwork, and furniture	12	
Roof (creosote base)	12	Pigments will settle and cake. Invert cans every 6 months.

<i>Material</i>	<i>Months</i> <i>40° F. to 90° F.</i>	<i>Remarks</i>
Varnish:		
Asphalt	18	
Oil (including spar)	18	Do not agitate in mechanical shaker

## FOOTNOTES:

(1) Water emulsion, water thinned, and latex or rubber base paints should be stored in heated areas or at least in areas where the temperature never falls below 40° F. to prevent freezing.

(2) Pressurized containers should never be stored in areas subject to extreme heat or cold. Optimum storage condition temperatures are in the range of 45° F. to 75° F.

(3) Particularly subject to settling action. If possible, containers should be either turned, or if any agitator is available, thoroughly agitated every 3 to 6 months while in storage.

(4) Most paint removers are highly volatile and rapid evaporation takes place when seals are not secure. Additionally, some removers are highly flammable and very caustic in contact with the skin. Care should be used in handling and storing.

## SECTION 4-2, PRIMERS, FILLERS, SEALERS AND PRESERVATIVES

### 4-2-1, PRETREATMENT-WASH PRIMER

**USE:** As a pretreatment on bare metal to produce a corrosion-resisting surface and provide mechanical adhesion between the metal and subsequent coats of paint. It is especially valuable in obtaining good paint bond to aluminum, brass, copper, cadmium-plated and galvanized steel. Also used as a pretreatment for plastic surfaces.

#### GENERAL APPLICATION INSTRUCTIONS

**Mixing:** Pretreatment-Wash Primer requires the mixing of 2 components before use, in the ratio of 4 volumes of resin component to 1 volume of acid component. The resin component should be first mixed thoroughly. Slowly pour the acid component into the resin component while stirring. After addition of acid component, mix thoroughly. Mix only enough for use within an 8-hour period. While no visible change in the mixture may be apparent 8 hours after mixing, poor adhesion will result if the Pretreatment-Wash Primer is used over 8 hours after mixing. When mixed the pretreatment should have viscosity approximately the same as thin shellac.

**Application:** Pretreatment-Wash Primer may be applied by brush, spray, dipping or swabbing. It may be applied at any temperature above 5° F. Special care is needed to insure that painting equipment is thoroughly clean, since alcohols used in this material will dislodge hardened particles of conventional paints. Brushes or spray equipment should be cleaned before and after use with denatured ethyl alcohol. A difference in pressure between spray gun and tank should be 20-30 lbs. Because of rapid solvent evaporation, spray gun must be kept within 8-10 in. of the work. The coating must be applied so as to give a thoroughly wet appearance to the freshly sprayed surface. Since only 1 coat is to be applied, it should be applied liberally to insure thorough coverage and adequate film

thickness. Solid hiding is not to be expected. With brush application apply liberally using brush to rapidly spread material. Do not attempt to brush out this material nor to eliminate overlaps and sags. Once the pretreatment has dried the next material should be applied as soon as possible (preferably within 24 hours) to avoid contamination of the clean surface by salt spray, oils, and other contaminants. Prolonged exposure will adversely effect the adhesion of subsequent coats. Where the Pretreatment-Wash Primer has for some reason not been overcoated within a week, a second thin coat of the wash primer should be applied to insure adhesion of the wash primer.

**Drying:** Drying time before recoating is about 15 minutes at 60° F. Lower temperatures may require a longer drying time.

**Thinning:** If mixed in the proper proportions, thinner will not normally be needed. Where a moisture problem exists, the addition of up to a pint per gallon of methyl ethyl ketone, ethyl, or butyl alcohol may promote adhesion. Clean brushes and spray equipment with denatured ethyl alcohol or isopropyl alcohol. Do not use common type thinners.

**PRECAUTIONS:** Pretreatment - Wash Primer is a flammable mixture presenting a fire and explosive hazard of the same order as shellac or other material containing ethyl alcohol. Insure positive and ample ventilation when mixing. Application on interior surfaces such as tanks and voids requires supervision to insure adequate ventilation and to exclude possible flames and sparks. Flash point 50° F.

#### SPECIFIC APPLICATION INSTRUCTIONS

- Article 2-2-1, Wood Surfaces
- Article 2-2-2(A), Exterior Ungalvanized Steel
- Article 2-2-2(B), Exterior Galvanized Steel and Corrosion-Resisting Metals other than Aluminum
- Article 2-2-2(C), Exterior Aluminum

#### 4-2-1

Article 2-2-2(D), Interior Ungalvanized Steel  
Article 2-2-2(E), Interior Galvanized Steel and Corrosion-Resisting Metals  
Article 2-2-2(F), Gutters, Downspouts and Flashing  
Article 2-2-2(G), Furniture and Equipment  
Article 2-2-2(H), Machinery, Shore Units  
Article 2-2-2(N), Interior Piping  
Article 2-2-8, Interior of Refrigeration Boxes  
Article 2-2-11, Surfaces Requiring Acid Resistance  
Article 2-3-1(A), Steel Vessels  
Article 2-3-2(A), Bottom Painting, General  
Article 2-3-2(B), Bottom Painting, Cold Plastic System  
Article 2-3-2(C), Bottom Painting, Vinyl System  
Article 2-3-2(G), Bottom Painting, Plastic Boats  
Article 2-3-3(A), Boot-top Painting, Steel Vessels in Salt Water — Cold Plastic System  
Article 2-3-3(B), Boot-top Painting, Steel Vessels in Salt Water — Vinyl System  
Article 2-3-4(A), Exterior Steel — General  
Article 2-3-4(B), Exterior Steel — Vinyl  
Article 2-3-5(A), Uninsulated Interior Metal Surfaces Not Subject to Moisture  
Article 2-3-5(B), Uninsulated Interior Metal Surfaces Subject to Moisture  
Article 2-3-6, Decks and Floor Plates  
Article 2-3-9, Voids and Cofferdams  
Article 2-3-11, Bilges  
Article 2-3-13, Spaces Subject to Heavy Condensation  
Article 2-3-14, Piping  
Article 2-3-15, Machinery, Shipboard  
Article 2-3-16, Furniture and Equipment  
Article 2-3-17, Electric Cable  
Article 2-3-18, Radio and Radar Antennas  
Article 2-3-19, Anchor Chain  
Article 2-3-21(B), Propeller Shafting (Inboard)  
Article 2-3-26(C), Sonar Domes and Transducers  
Article 2-3-28, Surfaces Requiring Acid Resistance  
Article 2-4-1, Exterior of Metal Buoys  
Article 2-5-2, Repainting of Vehicles

#### ORDERING INFORMATION

Description: Pretreatment-Wash Primer  
Specification: MIL-P-15328. Formula 117  

<i>Size Container</i>	<i>Stock Number</i>
1 gal.	CG8030-281-2726
5 gal.	FSS8030-165-8577

#### 4-2-2, QUICK DRYING RED

##### LEAD PRIMER (ALKYD VEHICLE)

USE: The standard steel primer for general Coast Guard use. Compound of red lead and zinc chromate. A high quality, heavy duty primer suitable for interior or exterior use under severe exposure conditions. When used over Pretreatment-Wash Primer this material is equal to Slow Drying Red Lead in all respects without the disadvantage of long drying periods.

##### GENERAL APPLICATION

##### INSTRUCTIONS

Apply 1 liberal coat of Pretreatment-Wash Primer. Follow with appropriate number of coats of Quick Drying Red Lead Primer.

Drying: Sets in 2 hours. Dries hard for recoating in 6 to 8 hours.

Thinning: This primer is of brushing consistency as received. For spraying, thin with Paint Thinner.

##### SPECIFIC APPLICATION

##### INSTRUCTIONS

Article 2-2-2(A), Exterior Ungalvanized Steel  
Article 2-2-2(B), Exterior Galvanized Steel and Corrosion-Resisting Metals other than Aluminum  
Article 2-2-2(D), Interior Ungalvanized Steel  
Article 2-2-2(F), Gutters, Downspouts and Flashing  
Article 2-2-2(G), Furniture and Equipment  
Article 2-2-2(H), Machinery, Shore Units  
Article 2-2-2(N), Interior Piping  
Article 2-2-5(B), Metal Roofs  
Article 2-2-8, Interior of Refrigeration Boxes  
Article 2-3-1(A), Steel Vessels  
Article 2-3-3, Boot-top Painting  
Article 2-3-4, Exterior of Vessel Above the Boot-top

Article 2-3-5, Interior of Vessels — General  
 Article 2-3-9, Voids and Cofferdams  
 Article 2-3-11, Bilges  
 Article 2-3-12, Inaccessible Spaces  
 Article 2-3-13, Spaces Subject to Heavy  
 Condensation  
 Article 2-3-14, Piping  
 Article 2-3-15, Machinery, Shipboard  
 Article 2-3-16, Furniture and Equipment  
 Article 2-3-21(B), Propeller Shafting,  
 Inboard  
 Article 2-5-2, Repainting of Vehicles

#### ORDERING INFORMATION:

Description: Maintenance Exterior Primer;  
 Red Lead Alkyd

Specification: MIL-P-17545, Formula 116

Color	Size	Container	Stock Number
Reddish-Brown	1 gal.		FSS8010-165-8573
Reddish-Brown	5 gal.		FSS8010-165-8574

#### 4-2-3, VINYL RED LEAD PRIMER

USE: This paint is intended for use as an anticorrosive coating only over a surface treated with Pretreatment-Wash Primer. It is not to be used over conventional paints nor as a substitute for red lead in conventional paint systems. When used over Pretreatment-Wash Primer, it is suitable for surfaces above and below water. Most common types of paint may be successfully applied over this paint. It is not a finish coat. It is designed for application of a finish coat of Vinyl-Alkyd Paint or Vinyl Antifouling Paint.

#### GENERAL APPLICATION INSTRUCTIONS

This paint may be applied at any temperature above 5° F. The surface must be dry. It may be applied over old well-adhering vinyl paint but not over conventional paints. This paint should never be applied to bare metal. Apply 1 liberal coat of Pretreatment-Wash Primer and follow with the specified number of coats of Vinyl Red Lead. Use orange color for initial and final coats and brown color for alternate coats to eliminate holidays.

Spraying: This paint is designed for spray application. Because of rapid solvent evaporation, the spray gun must be kept within 8 to 10 in. of the work. The objective is to

get a paint film that looks wet. Air pressure should be at least 15 psi above the liquid pressure. Each coat should consist of a vertical and a horizontal pass of the spray gun over the area. Special care is needed to insure that spray equipment is thoroughly clean before using this paint, since solvents used will dislodge hardened particles of conventional paints, causing the spray gun to clog frequently. Spray equipment should be cleaned with Vinyl Paint Thinner. Before use, charge equipment with Vinyl Paint Thinner and operate gun until all paint particles are cleared from the lines. Clean equipment immediately after use with Vinyl Paint Thinner.

Brushing: This paint is designed for spray application; however, it may be brushed on if applied properly. Take a full brush and spread it on without attempting to brush it out as with conventional paints. Due to the quick drying properties of this paint, do not attempt to cross work more than once. Stir paint frequently to prevent the pigment from settling.

Drying: Dries for recoating in 30 minutes at temperatures above 60° F. Lower temperatures may require slightly longer drying time.

Thinning: This paint is of spraying consistency as received. Since solvent evaporates rapidly, thinner may be required after the can has been open for some time. In cold weather, store paint in a warm place 24 hours before using. Warming and agitation may be required to reduce viscosity in cold weather. The proper thinner is Vinyl Paint Thinner. Do not attempt to use other thinners in this paint, as they are not compatible.

PRECAUTIONS: In mixing or using this paint in an enclosed area, particular attention should be given to the air temperature in the vicinity of application. If the air temperature is below the flash point of the paint (40° F.), the material can be applied with normal ventilation. When the air temperature is above that of the flash point, sufficient ventilation must be provided to insure that the vapor concentration does not exceed the lower limits of explosibility. In addition, usual paint precautions to keep open flames and sparks away from the painting area and the area where paints are mixed must be strictly enforced. Like most paint materials in com-

#### 4-2-4

mon use, adequate ventilation is necessary to avoid prolonged breathing of the concentrated paint fumes.

#### SPECIFIC APPLICATION INSTRUCTIONS

- Article 2-2-11, Surfaces Requiring Acid Resistance
- Article 2-3-2(C), Bottom Painting, Vinyl System
- Article 2-3-28, Surfaces Requiring Acid Resistance
- Article 2-4-1, Exterior of Metal Buoys

#### ORDERING INFORMATION

Description: Vinyl Red Lead Primer  
Specification: MIL-P-23281 (CG)

Color	Size Container	Stock Number
Orange	1 gal.	CG8010-285-4866
Orange	5 gal.	CG8010-285-4867
Brown	1 gal.	CG8010-285-4864
Brown	5 gal.	CG8010-285-4865

#### 4-2-4, SLOW DRYING RED LEAD PRIMER

USE: Commonly referred to as "Old Fashioned Red Lead." Use as an alternate for the Pretreatment-Wash Primer and Quick Drying Red Lead system where time will permit thorough drying of each coat; possesses excellent wetting properties on steel surfaces. Since it is seldom practical to allow adequate drying time for this material, Quick Drying Red Lead, which gives equal performance over a properly prepared surface is recommended.

#### GENERAL APPLICATION INSTRUCTIONS

Apply directly to clean, dry bare metal. In damp or cold weather apply 1 liberal coat of Pretreatment-Wash Primer and wait for suitable weather to apply the Red Lead.

Drying: Requires 36 hours drying time for each coat. Allow adequate drying time before recoating.

Thinning: This primer is of brushing consistency as received. For spraying, thin with Paint Thinner.

#### ORDERING INFORMATION

Description: Red Lead Primer, Ready-Mixed

Specification: Federal TT-P-86, Type 1

Color	Size Container	Stock Number
Reddish-Orange	1 gal.	FSS8010-244-5791
Reddish-Orange	5 gal.	FSS8010-244-5792

#### 4-2-5, ZINC CHROMATE PRIMER, ALKYD TYPE

USE: As a primer for aluminum or steel surfaces, particularly for marine service. The basic formulation provides a primer of yellow color.

#### GENERAL APPLICATION INSTRUCTIONS

Apply 1 liberal coat of Pretreatment-Wash Primer. Follow with appropriate number of coats of Yellow Zinc Chromate Primer.

Drying: Sets in 2 hours. Dries hard for recoating in 6 to 8 hours.

Thinning: Suitable for brush or spray application as received. If necessary, thin with Paint Thinner (TT-T-291, Grade 1).

#### SPECIFIC APPLICATION INSTRUCTIONS

- Article 2-2-2(C), Exterior Aluminum
- Article 2-2-2(F), Gutters, Downspouts and Flashing
- Article 2-3-4(D), Exterior Aluminum
- Article 2-3-17(A), Electric Cable
- Article 2-3-18, Radio and Radar Antennas

#### ORDERING INFORMATION

Description: Yellow Zinc Chromate, Alkyd Type

Specification: Federal TT-P-645, Formula 84/47

Color	Size Container	Stock Number
Yellow	1 gal.	FSS8010-161-7419
Yellow	5 gal.	FSS8010-165-8557

#### 4-2-6, ANTICORROSIVE SHIPBOTTOM PRIMER

USE: As an anticorrosive primer on the underwater hulls of steel vessels in conjunction with Cold Plastic Antifouling Paint serves as a barrier coat between steel and the antifouling paint.

#### GENERAL APPLICATION INSTRUCTIONS

Apply 1 liberal coat of Pretreatment-Wash Primer. Apply appropriate number of coats



of Anticorrosive Shipbottom Primer. On vessels in salt water, follow with appropriate number of coats of Cold Plastic Antifouling Paint. When applying this primer, use alternate coats of Formula 14N and 14ND. The only difference in these two formulations is one of color. The use of alternate color coats will eliminate holidays and insure adequate coverage.

**Drying:** Sets in 10 minutes. Dries hard for recoating in 3 hours.

**Thinning:** This primer is one of brushing and spraying consistency as received. If thinning is necessary, thin with Coal Tar Naphtha only.

#### SPECIFIC APPLICATION INSTRUCTIONS

Article 2-3-2(A), Bottom Painting, General

Article 2-3-2(B), Bottom Painting —  
Cold Plastic System

Article 2-3-3(A), Boot-top Painting,  
Steel Vessels in Salt Water —  
Cold Plastic System

#### ORDERING INFORMATION

Description: Anticorrosive Shipbottom Paint  
Specification: Formulas 14N and 14ND

*Formula No. Size Container Stock Number*

14N	5 gal.	FSS8010-550-8305
14ND	5 gal.	FSS8010-531-8557

#### 4-2-7, COPPER NAPHTHENATE WOOD PRESERVATIVE

**USE:** As a preservative for wood to prevent decay.

#### GENERAL APPLICATION INSTRUCTIONS

Apply by brush, spray, swab, dipping, soaking or flooding. Allow the wood to absorb as much preservative as possible. Paint, putty, seam compounds, or varnish may be applied over preservative without bleeding.

**Drying:** Allow preservative to dry 72 hours before applying other material.

**Thinning:** Thinning not normally needed. Thin if necessary with Paint Thinner.

**CAUTION:** Flammable. Irritating to the skin. Before using agitate thoroughly. Store

and use outdoors or in adequately ventilated rooms.

#### SPECIFIC APPLICATION INSTRUCTIONS

Article 2-3-1(B), Protective Coatings for  
Construction & Maintenance, Wooden  
Boats and Decks

Article 2-3-3(E), Boot-top Painting,  
Wooden Boats

Article 2-3-5(C), Interior Wood

Article 2-3-22, Wood Masts and Spars

#### ORDERING INFORMATION

Description: Wood Preservative, Copper  
Naphthenate, Type A

Specification: MIL-W-18142

<i>Color</i>	<i>Size Container</i>	<i>Stock Number</i>
Green	1 gal	FSS 8030-282-0971

#### 4-2-8, PASTE WOOD FILLER

**USE:** To fill the pores of open-grained woods, including floors, to permit the application of varnish or finish with minimum absorption.

#### GENERAL APPLICATION INSTRUCTIONS

Thin to brushing consistency and apply to bare wood by brushing across the grain. On stained wood, apply filler after stain is completely dry. Allow the filler to "flatten out", as characterized by a surface drying appearance, after which it is wiped or rubbed across the grain with a pad made of burlap.

**Drying:** After wiping clean, allow the filler to dry for 24 hours before applying finish coats.

**Thinning:** Thin the paste to brushing consistency with Paint Thinner.

#### SPECIFIC APPLICATION INSTRUCTIONS

Article 2-2-1(I), Interior Wood Floors

Article 2-2-1(J), Furniture Finishing

#### ORDERING INFORMATION

Description: Paste Wood Filler

Specification: Federal TT-F-336

<i>Color</i>	<i>Size Container</i>	<i>Stock Number</i>
Transparent	1/2 pt.	FSS8010-160-6897
Transparent	1 qt.	FSS8010-283-0512
Transparent	1 gal.	FSS8010-598-5765

#### 4-2-9

##### 4-2-9, FLOOR SEALER

USE: For sealing wood or cork floors to provide a satisfactory foundation for finishing materials such as floor wax.

##### GENERAL APPLICATION INSTRUCTIONS

Apply 1 thin coat by brush or lamb's wool mop. This sealer seals the pores of the flooring by absorption and leaves no apparent surface film. Allow it to dry and buff it in. "Natural" color.

Drying: Sets to touch in 1 to 3 hours. Dries hard in 7 hours.

Thinning: Thinning is not normally needed. Clean brushes and thin if necessary with Paint Thinner.

##### SPECIFIC APPLICATION INSTRUCTIONS

Article 2-2-1(I), Interior Wood Floors

##### ORDERING INFORMATION

Description: Floor Sealer, Non-pigmented  
Specification: Federal TT-S-176, Class I

<i>Size Container</i>	<i>Stock Number</i>
1 gal.	FSS8010-243-0961
5 gal.	FSS8010-243-0962

##### 4-2-10, EXTERIOR WOOD PRIMER

USE: As a priming coat on previously unpainted exterior wood. This primer should never be used as a top coat nor be exposed to the weather for more than 2 weeks.

##### GENERAL APPLICATION INSTRUCTIONS

Unpainted Wood: Spot prime knots and resin pockets in resinous wood with Ready-Mixed Aluminum Paint. Apply 1 coat of Exterior Wood Primer to clean, dry wood. Follow with number of coats and type of finish material prescribed for particular application.

Previously Painted Wood: Normally priming will not be needed. If old coatings have deteriorated to the extent that enough bare wood is exposed to warrant priming, apply 1 coat of Exterior Wood Primer to those effected areas. Follow with number of coats and type of finish material prescribed for particular application.

Drying: Sets to touch in 8 hours. Dries hard for recoating in 48 hours. Allow adequate drying time before applying top coats.

Thinning: This primer is of brushing consistency as received. If thinning is necessary, thin with Paint Thinner.

##### SPECIFIC APPLICATION INSTRUCTIONS

Article 2-2-1(A), Exterior Wood, General  
Article 2-2-5(A), Wood Roofs

##### ORDERING INFORMATION

Description: Exterior Wood, White Primer  
Specification: Federal TT-P-25

<i>Color</i>	<i>Size Container</i>	<i>Stock Number</i>
White	1 gal.	FSS8010-282-9414
White	5 gal.	FSS8010-165-8566

##### 4-2-11, INTERIOR WALL PRIMER- SEALERS

USE: For sealing unpainted interior plaster and wallboard to prevent suction spotting of finish coats. Two different types are available for use, as listed below.

(a) Federal Specification TT-P-56 is an oil pigmented wall sealer of the "controlled penetration" type supplied ready to use. New plaster contains much moisture and should not be primed until the plaster is dry. If 1 coat does not give a uniform appearance, a second coat should be applied to the suction spots. Dries hard for recoating within 24 hours. Follow with the number of coats and type of finish prescribed.

(b) Federal Specification TT-P-650 is a latex base primer suitable for plaster or wallboard. Available in ready-mixed form (Type I). May be recoated within 4 hours. Do not thin with Paint Thinner.

##### SPECIFIC APPLICATION INSTRUCTIONS

Article 2-2-3(C), Interior Walls  
Above Grade

Article 2-2-4, Coating System for Dry Wall  
Construction

##### ORDERING INFORMATION

Description: Interior Wall Primer-Sealer  
Specification: Federal TT-P-56

Color	Size Container	Stock Number
White	1 gal.	FSS8010-165-8569
White	5 gal.	FSS8010-165-8570

Specification: Federal TT-P-650, Type I  
(Ready-Mixed)

Color	Size Container	Stock Number
White	1 gal.	FSS8010-754-2610
White	5 gal.	FSS8010-754-2611

#### 4-2-12, INTERIOR WHITE ENAMEL UNDERCOAT

USE: As an undercoat for interior gloss and semi-gloss enamels.

##### GENERAL APPLICATION INSTRUCTIONS

New, dry plaster, composition wallboard, should first be sealed with Interior Wall Primer-Sealer. Apply 1 coat of Undercoat as received. Follow with the number of coats and type of finish material specified for the particular surface.

New or Previously Unpainted Wood: Apply 1 coat of Undercoat as received. Follow with the number of coats and type of finish material specified for the particular surface being painted.

Drying: Sets to touch in 1/2 to 2 hours. Dries hard for recoating in 7 hours. Allow adequate drying time before applying finish material.

Thinning: This paint is of brushing consistency as received. If thinning is necessary, thin with Paint Thinner.

##### SPECIFIC APPLICATION INSTRUCTIONS

Article 2-2-1(H), Interior Wood Trim  
Article 2-2-3(C), Interior Walls Above  
Grade

Article 2-2-4, Coating System for  
Dry Wall Construction

Article 2-2-8, Interior of Refrigeration  
Boxes

Article 2-3-5(C), Interior Wood

##### ORDERING INFORMATION

Description: Interior Enamel Undercoat  
Specification: Federal TT-E-543

Color	Size Container	Stock Number
White	1 qt.	FSS8010-223-6001
White	1 gal.	FSS8010-281-2809

#### 4-2-13, THIN-FILM RUST PREVENTIVE

USE: Grade 1: On ferrous and other corrodible metals exposed to the weather. Resistant to salt spray for a limited period.

Grade 2: On ferrous and other corrodible metals where undercover storage is provided; on interior and on exterior surfaces of all machines and instruments, and on all interiors of gasoline and diesel engines (except water jackets).

##### GENERAL APPLICATION INSTRUCTIONS

Apply 1 coat by brush or spray gun which will give a film thickness of approximately 2 mils. Will not corrode steel, copper, brass or aluminum. Contains no abrasive. Transparent but with sufficient color to be discernible during the protective life of the film. This material may be removed with rags saturated with kerosene or Paint Thinner.

Drying: May be tacky for several months.

Thinning: Not needed. Clean brushes and spray equipment with Paint Thinner.

CAUTION: When spraying these compounds, the operator and others exposed to the mist shall wear respirators. Adequate means shall be used to entrap the mist near the operation. When brushing or dipping, adequate ventilation shall be maintained to reduce the concentration of the solvent vapor.

##### SPECIFIC APPLICATION INSTRUCTIONS

Article 2-2-2(M), Interior of Steel Fuel  
and Lube Oil Tanks

Article 2-3-8, Fuel Oil Tanks

Article 2-3-12, Inaccessible Spaces

##### ORDERING INFORMATION

Description: Thin-Film Rust Preventive  
Specification: MIL-C-16173

Grade 1: For Surfaces Exposed  
to the Weather

Size Container	Stock Number
1 gal.	FSS8030-231-2345

Grade 2: For Surfaces Where  
Undercover Storage Is Provided

Size Container	Stock Number
1 gal.	FSS8030-244-1297
5 gal.	FSS8030-244-1298

## SECTION 4-3, PAINTS AND ENAMELS

### 4-3-1, EXTERIOR OIL PAINT, GENERAL PURPOSE

LUSTER: Semi-Gloss

USE: Class A for finish on exterior wood siding, walls, fences, lattices, posts, etc., where a self-cleaning "white paint" is desired. A general purpose exterior paint to be used for all purposes where no special purpose paint is required. In areas where sulfide fumes are encountered, use Exterior Oil Paint, Fume-Resistant. Class B covers tinted paints and non-chalking white. For masonry, use Acrylic Emulsion Paint.

#### GENERAL APPLICATION INSTRUCTIONS

Unpainted Wood Surfaces: Prime with 1 coat of Exterior Wood Primer as received. Follow with 2 coats of paint as received.

Drying: Sets to touch in 6 hours and dries hard for recoating in 18 hours. Allow adequate drying time between coats.

Thinning: This paint is of brushing consistency as received. For spraying, thin with Paint Thinner.

#### SPECIFIC APPLICATION INSTRUCTIONS

Article 2-2-1(A), Exterior Wood, General  
Article 2-2-1(F), Previously Stained Wood  
Shingles and Siding

### 4-3-2, EXTERIOR OIL PAINT, FUME-RESISTANT

LUSTER: Semi-gloss

USE: As a finish coat over a suitable primer on exterior wood, where sulfide fumes are encountered such as buildings in certain industrial areas or near sewer outlets. For a general purpose exterior paint use Exterior Oil Paint, General Purpose.

#### GENERAL APPLICATION INSTRUCTIONS

Unpainted Wood Surfaces: Prime with 1 coat of Exterior Wood Primer as received.

Previously Painted Surfaces: Priming is not needed. Apply 2 coats of the paint as received.

Drying: Sets to touch in 6 hours and dries hard for recoating in 18 hours. Allow adequate drying time between coats.

---

#### ORDERING INFORMATION (Article 4-3-1)

Catalog Name: Exterior Oil Paint, General Purpose  
Description: Federal TT-P-102; Class A, White Only  
Class B, Tints and Nonchalking White

<i>Color</i>	<i>Federal Color No.</i>	<i>Size Container</i>	<i>Stock Number</i>
White		1 gal.	FSS8010-290-4049 (Class A)
		5 gal.	FSS8010-290-4050 (Class A)
No. 11 Sun Tan*	13613	1 gal.	FSS8010-527-3195 (Class B)
No. 12 Spruce Green**	14159	1 gal.	FSS8010-616-7500 (Class B)
No. 19 Light Gray	26251	1 gal.	FSS8010-577-4523 (Class B)
No. 7 Coral	31433	1 gal.	To be assigned
		5 gal.	To be assigned
No. 23 Turquoise	35299	1 gal.	To be assigned
		5 gal.	To be assigned

\*Note: GSA color description, Ivory Cream

\*\*Note: Available from Federal Supply Service  
under Federal Specification TT-E-489, Class A

Thinning: This paint is of brushing consistency as received. For spraying, thin with Paint Thinner.

#### SPECIFIC APPLICATION INSTRUCTIONS

Article 2-2-1(A), Exterior Wood, General

#### ORDERING INFORMATION

Description: Exterior Oil Paint, Semi-Gloss,  
Special Fume-Resistant

Specification: Federal TT-P-103

<i>Color</i>	<i>Size</i>	<i>Container</i>	<i>Stock Number</i>
White	1 gal.		FSS8010-286-8493
	5 gal.		FSS8010-286-8494

#### 4-3-3, EXTERIOR VINYL ALKYD ENAMEL

LUSTER: Semi-gloss

USE: Primarily as an exterior topcoat on metal surfaces which have been treated with Pretreatment-Wash Primer and primed with Vinyl Red Lead Primer. Used extensively on buoys.

#### GENERAL APPLICATION INSTRUCTIONS

This paint may be applied over firmly adhering, age hardened conventional paints (with the exception of paints based on coal tar and asphalt) on wood and metal surfaces. It will not adhere if applied directly to wood, and may lift conventional paint films recently applied. Best results are achieved only over paints of the vinyl system; therefore it is

desirable, on a surface previously painted with other than vinyl paint, to remove the old coatings to bare metal. Apply 1 liberal coat of Pretreatment-Wash Primer to bare metal. Prime the surface with sufficient coats (usually 2 coats) of Vinyl Red Lead to give a dry film thickness of 4 mils. Follow with sufficient coats (usually 2 coats) of Vinyl Alkyd Paint to give a dry film thickness of 3 mils and a total dry film thickness of 7.5-10 mils for the system.

Spraying: This paint is designed for spray application. Because of rapid solvent evaporation, the spray gun must be kept within 8 to 10 in. of the work. The objective is to get a paint film that looks wet. Air pressure should be at least 40 psi above the liquid pressure. Each coat should consist of a vertical and a horizontal pass of the spray gun over the area. Special care is needed to insure that spray equipment is thoroughly clean before using this paint, since solvents used will dislodge hardened particles of conventional paints, causing the spray gun to clog frequently. Spray equipment should be cleaned with Vinyl Paint Thinner before use. Before use, charge equipment with Vinyl Paint Thinner and operate gun until all paint particles are cleared from the lines. Clean equipment immediately after use with Vinyl Paint Thinner.

Brushing: This paint is designed for spray application; however, it may be brushed on if applied properly. Take a full brush and spread it on without attempting to brush it

---

#### ORDERING INFORMATION (Article 4-3-3)

Description: Exterior Vinyl Alkyd Enamel

Specification: CGS-52P-5

<i>Coast Guard Color</i>	<i>Federal Color No.</i>	<i>Size Container</i>	<i>Stock Number</i>
Black	27038	1 gal.	CG8010-290-7290
White	27875	1 gal.	CG8010-290-7293
No. 13 Fire Red	21105	1 gal.	CG8010-290-7292
No. 18 International Orange*	12197	1 qt.	CG8010-290-7291

\*Note: When exhausted, to be replaced by  
(TT-E-489) FSS8010-527-3202

---

#### 4-3-4

out as with conventional paints. Due to the quick drying properties of this paint, do not attempt to cross work more than once. Stir paint frequently to prevent the pigment from settling.

**Drying:** Dries for recoating in 45 minutes at temperatures above 60° F. Lower temperatures may require slightly longer drying time.

**Thinning:** This paint is of spraying consistency as received. Since solvent evaporates rapidly, thinner may be required after the can has been open for some time. In very cold weather, store paint in a warm place 24 hours before using. Thinner may be required to reduce viscosity in cold weather. The proper thinner is Vinyl Paint Thinner. Do not attempt to use other thinners in this paint.

**PRECAUTIONS:** In mixing or using this paint in an enclosed area, particular attention should be given to the air temperature in the vicinity of application. If the air temperature is below the flash point, sufficient ventilation must be provided to insure that the vapor concentration does not exceed the lower limits of explosibility. In addition, usual paint precautions to keep open flames and sparks away from the painting area and the area where paints are mixed must be strictly enforced. Like most paint materials in common use, adequate ventilation to avoid prolonged breathing of the concentrated paint fumes is necessary.

#### SPECIFIC APPLICATION INSTRUCTIONS

Article 2-2-11, Surfaces Requiring Acid Resistance

Article 2-3-4(B), Exterior of Vessels Above Boot-top

Article 2-3-28, Surfaces Requiring Acid Resistance

Article 2-4-1, Exterior of Metal Buoys

Article 2-4-2, Interior of Metal Buoys

#### 4-3-4, EXTERIOR GLOSS ENAMEL

**LUSTER:** High gloss

**USE:** Recommended for the exterior and interior of metal surfaces where toughness, weather resistance, high gloss and freedom from chalking are desired. The following

examples illustrate some of the typical uses of this enamel:

- Exterior of vessels above the boot-top
- Automobiles
- Buoys (limited use)
- Signs
- Gas Cylinders
- Striping and Marking Enamel

#### GENERAL APPLICATION INSTRUCTIONS

**Unpainted Metal Surfaces:** Apply 1 liberal coat of Pretreatment-Wash Primer. Prime surfaces with appropriate number of coats of Quick Drying Red Lead Primer (prime aluminum with Yellow Zinc Chromate Primer). Follow with 2 coats of Exterior Gloss Enamel as received.

**Previously Painted Surfaces in good condition:** Priming not needed. Apply 1 coat enamel as received.

**Thinning:** For spraying, thin with Paint Thinner. For thinning in excess of 1 part thinner to 4 parts paint, use Synthetic Enamel Thinner in lieu of Paint Thinner.

#### SPECIFIC APPLICATION INSTRUCTIONS

Article 2-2-1(C), Exterior Wood Signs

Article 2-2-1(E), Creosoted Wood

Article 2-2-2(A), Exterior Ungalvanized Steel

Article 2-2-2(B), Exterior Galvanized Steel and Corrosion-Resisting Metals other than Aluminum

Article 2-2-2(C), Exterior Aluminum

Article 2-2-8, Interior of Refrigeration Boxes

Article 2-3-4(A), Exterior Steel, General

Article 2-3-4(D), Exterior Aluminum

Article 2-3-4(E), Exterior Wood

Article 2-3-17, Electric Cable

Article 2-3-18, Radio and Radar Antennas (Vessels)

Article 2-3-22, Wood Masts and Spars

Article 2-4-3, Metal Buoys with High Loss Probability

Article 2-4-4, Color Renewal on Station

Article 2-5-2, Repainting of Vehicles

## ORDERING INFORMATION (Article 4-3-4)

Description: Exterior Gloss Enamel  
 Specification: Federal TT-E-489c,  
 Class A, Air Drying

<i>Coast Guard Color</i>	<i>Federal Color No.</i>	<i>Size Container</i>	<i>Stock Number</i>
No. 14 Brilliant Yellow	13538	1 qt.	FSS8010-286-7758
		1 gal.	FSS8010-527-2045
No. 13 Fire Red	11105	1 qt.	CG8010-286-7756
		1 gal.	FSS8010-616-7486
		5 gal.	FSS8010-616-7487
		1 qt.	FSS8010-515-1596
White	17875	1 gal.	FSS8010-664-4761
		5 gal.	FSS8010-286-9088
		1 qt.	FSS8010-527-2053
Black	17038	1 gal.	FSS8010-527-2050
		5 gal.	FSS8010-286-7725
		1 qt.	CG8010-286-7760
No.16 Bright Green	14260	1 gal.	FSS8010-530-5563
No. 29 Bright Blue	15123	1 qt.	CG8010-286-7759
		1 gal.	FSS8010-853-1859
No. 22 High-Light Buff*	13578	1 gal.	FSS8010-584-3081
No. 18 International Orange	12197	1 qt.	FSS8010-527-3202
		1 gal.	FSS8010-527-3200
No. 33 Seal Brown	10080	1 gal.	FSS8010-286-7737
No. 24 Spar**	10371	1 gal.	FSS8010-285-3544
No. 19 Light Gray	16251	1 gal.	FSS8010-584-3077
No. 20 Medium Gray	16187	1 gal.	FSS8010-286-7731
No. 7 Coral	21433	1 gal.	To be assigned
		5 gal.	To be assigned
No. 23 Turquoise	25299	1 gal.	To be assigned
		5 gal.	To be assigned

\*Identical to GSA description, Warm Gray

\*\*Identical to GSA description, Buff

#### 4-3-5, ACRYLIC EMULSION PAINT FOR MASONRY

LUSTER: Eggshell

USE: As a finish coat on interior and exterior concrete and masonry walls. For concrete floors use Basement Floor Paint or Deck and Floor Enamel as applicable.

#### GENERAL APPLICATION INSTRUCTIONS

Unpainted Masonry: It is not necessary to allow new masonry to dry for an appreciable period before painting, but a minimum of

10 days of good dry weather should elapse for best results. Unless the surface is extremely porous, i.e., cinder block, or rough stucco, apply directly 2 coats of the Acrylic Emulsion Paint as received. Cinder block should receive a fill coat or grout coat outlined in Article 2-2-3 before the 2 coats of Acrylic Emulsion Paint are applied.

Previously Painted Masonry: Old coatings of oil paint or cement-water paint in sound condition need not be removed. However, peeling, flaking, scaling, excessively chalked paints or whitewash should be completely removed. Also any efflorescence shall be com-

---

 ORDERING INFORMATION (Article 4-3-5)

Description: Acrylic Emulsion Paint for Masonry Surfaces (Do not store in freezing temperatures)  
 Specification: Interim Federal TT-P-0019 (ARMY-CE)

<i>Color</i>	<i>Federal Color No.</i>	<i>Size Container</i>	<i>Stock Number</i>
White	37875	1 gal.	CG8010-823-7962
Sun Tan*	33613	1 gal.	CG8010-853-8146
Light Gray*	36251	1 gal.	CG8010-823-7963
Seal Brown*	10080	1 gal.	CG8010-823-7965
Black*	37038	1 gal.	CG8010-823-7964

\*Will be discontinued when stocks are exhausted

---

pletely removed. Then apply 2 coats of Acrylic Emulsion Paint as received. If operating conditions prohibit complete removal, a primer sealant clear alkali resistant varnish of low solids content should be applied. Spar varnish conforming to Military Specification MIL-V-1174, Stock Numbers FSS8010-234-5176 or FSS8010-166-1669 and slightly thinned with mineral spirits (TT-T-291, Grade 1) is suggested. Apply 2 coats of Acrylic Emulsion Paint as received.

Drying: Set-to-touch in 15 minutes. Dries hard for recoating in 1 hour.

Thinning: This paint is of brushing consistency as received. If thinning is necessary, thin cautiously with fresh or distilled water. DO NOT THIN WITH TURPENTINE, MINERAL SPIRITS, OR XYLENE; these thinners are not miscible with acrylic emulsion paints.

## SPECIFIC APPLICATION

## INSTRUCTIONS

Article 2-2-3(A), Exterior Walls Above Grade

**4-3-6, TILE RED ROOF PAINT**

USE: As a finish on wood and metal roofs.

## GENERAL APPLICATION

## INSTRUCTIONS

Unpainted Wood: Prime with 1 coat of Exterior White Wood Primer. Follow with 2 coats of paint as received.

Unpainted Metal: Prime with 1 liberal coat of Pretreatment-Wash Primer and 1 coat of Quick Drying Red Lead Primer. Follow with 2 coats of paint as received.

Previously Stained Wood: Prime and seal with 2 coats of Ready-Mixed Aluminum Paint. Follow with 2 coats of paint as received.

Previously Painted Surfaces: Priming is not needed. Apply 1 coat of paint as received.

Drying: Dries overnight to a soft film. Several days drying time needed between coats.

Thinning: This paint is of brushing consistency as received. For spraying, thin with Paint Thinner.

---

 ORDERING INFORMATION (Article 4-3-6)

Description: Tile Red Roof Paint  
 Specification: Federal TT-P-31

<i>Coast Guard Color</i>	<i>Federal Color No.</i>	<i>Size Container</i>	<i>Stock Number</i>
No. 26 Tile Red	10076 (Approx.)	1 gal.	FSS8010-286-9049

---



**SPECIFIC APPLICATION  
INSTRUCTIONS**

Article 2-2-5(A), Wood Roofs  
Article 2-2-5(B), Metal Roofs

**4-3-7, DECK AND FLOOR ENAMEL**

USE: As a finish coat on interior or exterior metal and wood decks, floors, steps, concrete floors above grade, and miscellaneous traffic areas. On concrete floors in contact with the ground, use Basement Floor Paint.

**GENERAL APPLICATION  
INSTRUCTIONS**

Unpainted Wood Surfaces: Prime with 1 coat of Deck and Floor Paint thinned with 1 qt. of thinning mixture ( $\frac{2}{3}$  Boiled Linseed Oil and  $\frac{1}{3}$  Paint Thinner) per gal. of paint. On interior floors, follow with 1 coat of Deck and Floor Enamel as received. On exterior floors follow the prime coat with 2 coats of Deck and Floor Enamel as received.

Unpainted Metal Surfaces: Apply 1 liberal coat of Pretreatment-Wash Primer. Prime surfaces with appropriate number of coats of Quick Drying Red Lead Primer (prime aluminum with Yellow Zinc Chromate Primer). Follow with 2 coats of Deck and Floor Enamel as received.

Unpainted Concrete Above Grade: Prepare the surface and apply 2 coats of enamel as received.

Previously Painted Surfaces: Priming not needed. Apply 2 coats paint as received.

Drying: Sets to touch in 2 hours. Dries hard for recoating in 18 hours.

Thinning: This paint is of brushing consistency as received. For spraying, thin with Paint Thinner.

**SPECIFIC APPLICATION  
INSTRUCTIONS**

Article 2-2-1(B), Exterior Floors, Decks, Steps, Bleachers  
Article 2-2-1(I), Interior Wood Floors  
Article 2-2-2(I), Metal Traffic Areas  
Article 2-2-3(E), Concrete Floors Both Above and Below Grade  
Article 2-3-6, Decks and Floor Plates

**4-3-8, BASEMENT FLOOR PAINT**

USE: A rubber-base solvent type paint for use on interior concrete floors, especially basement and other concrete floors in direct contact with the ground which are subject to dampness. It is not intended for exterior use. This paint cannot be applied over other conventional types of paint.

**GENERAL APPLICATION  
INSTRUCTIONS**

Unpainted Concrete: Apply to clean, bare, dry concrete floors. New concrete floors must be aged for 2 months prior to applying this paint. Floors with hard slick surfaces should be acid etched by flooding (1 gal. to 100 sq. ft.) with a mixture of 1 gal. of muriatic acid added to 4 gals. of water. After 15 minutes, hose off the acid using plenty of water. Allow the floor to dry thoroughly before painting. At least 2 coats should be applied

---

**ORDERING INFORMATION (Article 4-3-7)**

Description: Deck and Floor Enamel  
Specification: Federal TT-E-487

<i>Color</i>	<i>Federal Color No.</i>	<i>Size Container</i>	<i>Stock Number</i>
No. 26 Tile Red	10076	1 gal.	FS8010-285-4863
No. 31 Deck Green	24172	1 gal.	CG8010-285-4862
No. 19 Light Gray	16251	1 gal.	CG8010-285-4860
No. 20 Medium Gray	16187	1 gal.	FS8010-527-0216
No. 32 Blue Gray	16099	1 gal.	CG8010-285-4859

---

---

 ORDERING INFORMATION (Article 4-3-8)

Description: Paint, Rubber-Base, for Concrete Floors  
 Specification: Federal TT-P-91

<i>Color</i>	<i>Federal Color No.</i>	<i>Size Container</i>	<i>Stock Number</i>
No. 26 Tile Red*	10076	1 gal.	FSS8010-285-2676
Light Gray	16376	1 gal.	FSS8010-597-8219

\*Identical in color to GSA Reddish-Brown

---

and for extreme wear resistance 3 coats are recommended.

Previously Painted Floors: If a non-rubber base paint was previously used it should be removed with paint remover and the surface thoroughly scrubbed with soap and water. Treat as unpainted concrete.

CAUTION: This paint should be stored under good conditions (40° to 90° F.).

Drying: Sets to touch in 1 hour. Dries hard for recoating in 8 hours. Allow 48 hours after last coat before subjecting the floor to traffic.

Thinning: This paint is of brushing consistency as received. For spraying, thin with Synthetic Enamel Thinner.

#### SPECIFIC APPLICATION INSTRUCTIONS

Article 2-2-3(E), Concrete Floors, both  
Above and Below Grade

#### 4-3-9, EQUIPMENT ENAMEL

LUSTER: Semi-Gloss

USE: On metal furniture and equipment such

as laundry machinery and galley equipment and miscellaneous equipment of all types. On ship's joiner doors, switch boxes, controllers, switchboards, gauge boards and connection boxes. On interior machinery surfaces which do not exceed 300° F.

#### GENERAL APPLICATION INSTRUCTIONS

Unpainted Metal: Apply 1 liberal coat of Pretreatment-Wash Primer. Prime surfaces with appropriate number of coats of Quick Drying Red Lead Primer (prime aluminum with Yellow Zinc Chromate Primer). Follow with 2 coats of the enamel.

Drying: Sets to touch in 1 hour. Dries hard for recoating in 8 hours.

Thinning: This paint is of brushing consistency as received. If thinning is necessary, thin with Paint Thinner.

#### SPECIFIC APPLICATION INSTRUCTIONS

Article 2-2-2(G), Furniture and Equipment  
Article 2-2-2(H), Machinery, Shore Units

---

 ORDERING INFORMATION (Article 4-3-9)

Description: Light Gray Equipment Enamel, Medium  
Air Drying, Type 1, Class 2, Semi-Gloss

Specification: MIL-E-15090, Formula 111

<i>Color</i>	<i>Federal Color No.</i>	<i>Size Container</i>	<i>Stock Number</i>
Light Gray*	16307	1 qt.	CG8010-285-4858
		1 gal.	FSS8010-285-4868

\*GSA color description

---

Article 2-3-15(A), Interior Machinery  
 Article 2-3-16(A), Furniture and  
 Equipment, Interior  
 Article 2-3-21(B), Propeller Shafting,  
 Inboard

#### 4-3-10, INTERIOR GLOSS ENAMEL

LUSTER: High gloss

USE: For general purpose use on the interiors of vessels. Also on interior walls, ceilings and woodwork of galleys, heads, sick bays and other sanitary spaces in shore establishments where the surfaces are frequently scrubbed. Also for general use on wood and metal doors, door sash, window sash, baseboard, dados, etc., which must be frequently scrubbed. For a general purpose wall and ceiling paint in other than sanitary spaces for shore activities, use Interior Latex Emulsion Paint.

#### GENERAL APPLICATION INSTRUCTIONS

Unpainted Plaster and Porous Wallboard Surfaces: Seal surface with 1 coat of Interior Wall Primer-Sealer. Prime with 1 coat of Interior White Enamel Undercoat. Follow

with 1 coat of Interior Gloss Enamel as received.

Unpainted Wood and Non-Porous Wallboard Surfaces: Prime with 1 coat of Interior White Enamel Undercoat as received. Follow with 1 coat of Interior Gloss Enamel as received.

Unpainted Metal Surfaces: Apply 1 liberal coat of Pretreatment-Wash Primer. Prime surfaces with appropriate number of coats of Quick Drying Red Lead Primer (prime aluminum with Yellow Zinc Chromate Primer). Follow with 1 coat of White Enamel Undercoat and 1 coat of Interior Gloss Enamel as received.

Previously Painted Surfaces: Priming is not needed if the surface is in good condition and not too glossy. If the surface has a high gloss it may be necessary to either roughen the surface with sandpaper or to apply a coat of the Enamel Undercoat as received. Apply 1 coat of Interior Gloss Enamel.

Drying: Sets to touch in 2 hours and dries hard for recoating in 7 hours. Allow adequate drying time between coats.

Thinning: This paint is of brushing and spraying consistency as received. If thinning

---

#### ORDERING INFORMATION (Article 4-3-10)

Description: Interior Gloss Enamel  
 Specification: Federal TT-E-506

<i>Coast Guard Color</i>	<i>Federal Color No.</i>	<i>Size Container</i>	<i>Stock Number</i>
White	17875	1 qt.	FSS8010-297-2110
		1 gal.	FSS8010-290-2865
		5 gal.	FSS8010-286-7836
No. 1 Light Green	14516	1 gal.	FSS8010-582-1515
No. 2 Medium Green	14277	1 gal.	FSS8010-582-1517
No. 4 Soft Yellow	13695	1 gal.	FSS8010-616-0000
No. 6 Ivory	13711	1 gal.	FSS8010-582-1513
No. 25 Beach Sand*	12645	1 gal.	FSS8010-577-4131
No. 8 Terra Cotta	10233	1 gal.	FSS8010-616-7686
No. 9 Pearl Gray	16492	1 gal.	FSS8010-582-1508
No. 10 Light Blue	15526	1 gal.	FSS8010-577-4130
No. 7 Coral	21433	1 gal.	To be assigned
No. 23 Turquoise	25299	1 gal.	To be assigned

\*When ordering this color from GSA sources, specify Light Orange, Federal Color No. 12648

#### 4-3-11

is found necessary, thin with Synthetic Enamel Thinner and compensate for reduction in paint film thickness by applying a heavier than normal coat.

#### SPECIFIC APPLICATION INSTRUCTIONS

- Article 2-2-1(H), Interior Wood Trim
- Article 2-2-2(D), Interior Ungalvanized Steel
- Article 2-2-2(E), Interior Galvanized Steel and Corrosion-Resisting Metals
- Article 2-2-3(C), Interior Walls Above Grade
- Article 2-2-4, Coating System for Dry Wall Construction
- Article 2-3-5(A), Uninsulated Interior Metal Surfaces Not Subject to Moisture
- Article 2-3-5(B), Uninsulated Interior Metal Surfaces Subject to Moisture
- Article 2-3-5(C), Interior Wood
- Article 2-3-5(D), Interior Plastic
- Article 2-3-9, Voids and Cofferdams
- Article 2-3-13, Spaces Subject to Heavy Condensation
- Article 2-3-14(A), Interior Piping
- Article 2-3-17(A), Electric Cable, Interior

#### 4-3-11, ENAMEL, FIRE-RETARDANT

LUSTER: Semi-gloss

USE: For shipboard application on the interiors of metal bulkheads and overheads in habitability spaces. Reduction of fire hazards, due to extremely limited flame spread in the event of fire from other sources. Formulated with antimony oxide and chlorinated

alkyd resin. New formulas have reduced objectionable yellowing characteristics of previously used paints of this type. This enamel is not intended to prevent the burning of wood or other combustible substrates, but will retard combustion. Available in three colors: Soft White, Pastel Green and Equipment Gray.

#### GENERAL APPLICATION INSTRUCTIONS

Unpainted Metal Surfaces: Apply 1 liberal coat of Pretreatment-Wash Primer. Prime with appropriate number of coats of Quick Drying Red Lead Primer (prime aluminum with Zinc Chromate Primer). Follow with 2 coats of Fire-Retardant Enamel.

Drying: Sets to touch in 2 hours. Dries hard within 7 hours.

Thinning: This enamel can be brushed or sprayed. If excessive brush drag is experienced, thin with conventional Paint Thinner.

Flash Point: Not under 100° F.

#### SPECIFIC APPLICATION INSTRUCTIONS

- Article 3-11-2, Interior Colors for Vessels 65 Ft. and Over in Length

#### 4-3-12, INTERIOR LATEX EMULSION PAINT (FLAT)

LUSTER: Low Gloss

USE: On interior walls, ceilings, and woodwork as a general purpose paint on properly primed plaster, wallboard, wood, masonry. Good washability after 30 days.

---

#### ORDERING INFORMATION (Article 4-3-11)

Description: Enamel, Fire-Retardant

Specifications: MIL-E-17970 (White Enamel) Form. 124/58

MIL-E-17971 (Pastel Green) Form. 125/58

MIL-E-17972 (Equipment Gray) Form. 126/58

<i>Color</i>	<i>Federal Color No.</i>	<i>Size Container</i>	<i>Stock Number</i>
Soft White	—	1 gal.	FSS8010-577-4738
Equipment Gray	—	1 gal.	FSS8010-577-4736
Pastel Green	24664 (Approx.)	1 gal.	FSS8010-577-4734

## ORDERING INFORMATION (Article 4-3-12)

Description: Latex Emulsion Paint  
Specification: Federal TT-P-29, Type I

<i>Color</i>	<i>Federal Color No.</i>	<i>Size Container</i>	<i>Stock Number</i>
White	37875	1 gal.	FSS8010-598-5733
No. 1 Light Green	34516	1 gal.	FSS8010-584-3353
No. 2 Medium Green	34277	1 gal.	FSS8010-584-3354
No. 4 Soft Yellow	33695	1 gal.	FSS8010-579-9204
No. 6 Ivory	33711	1 gal.	FSS8010-584-3356
No. 26 Beach Sand*	31670	1 gal.	FSS8010-579-9199
No. 9 Pearl Gray	36492	1 gal.	FSS8010-584-3358
No. 10 Light Blue	35526	1 gal.	FSS8010-598-5737
No. 8 Terra Cotta	30233	1 gal.	CG8010-527-2494
No. 7 Coral	31433	1 gal.	To be assigned
No. 23 Turquoise	35299	1 gal.	To be assigned

\*When ordering this color from GSA sources, specify Peach, Federal Color 31670

#### GENERAL APPLICATION INSTRUCTIONS

Unpainted Plaster, Masonry, Wood and Wall-board Surfaces: Priming normally not needed unless surface is extremely porous, in which case apply a coat of Interior Wall Primer-Sealer followed by the Interior Latex Emulsion Paint.

Previously Painted Surfaces: Priming not needed. Apply 1 coat of the paint as received.

Drying: Sets to touch in 20 minutes and dries hard for recoating in 24 hours. Allow adequate drying time between coats. A period of 30 days should be allowed for a curing process with this paint. During this period the surfaces should not be washed. After the process is completed the washability approaches that of an oil paint.

Thinning: This paint should be satisfactory for either brush or spray application as received. If thinning becomes necessary, thin with water. Clean brushes and spray equipment with water or soap and water.

CAUTION: Do not store where temperature falls below 40° F., otherwise the emulsion will freeze and may result in unuseable paint.

#### SPECIFIC APPLICATION INSTRUCTIONS

Article 2-2-1(G), Interior Wood Walls

and Wood Wainscoting  
Article 2-2-3(C), Interior Walls Above Grade  
Article 2-2-3(D), Interior Walls Below Grade  
Article 2-2-4, Coating Systems for Dry Wall Construction

#### 4-3-13, STRIPING PAINT

Exterior Gloss Enamel, Article 4-3-4, is to be used as a striping paint where necessary. Exterior Gloss Enamel is suitable for all purposes for which a striping paint is used.

Some of the colors of Exterior Gloss Enamel are stocked in 1 qt. containers while in other colors 1 gal. containers are the smallest stocked.

#### 4-3-14, VINYL BOOT-TOPPING PAINT, BLACK

USE: As a boot-topping paint on steel, wood, and plastic vessels with white hulls.

#### GENERAL APPLICATION INSTRUCTIONS

This paint may be applied at any temperature over 5° F. The surface must be dry. It may be applied over well-adhering vinyl paint, but not over conventional paint, since lifting

#### 4-3-15

may occur. This paint should not be applied over bare steel as galvanic corrosion will result.

**Steel Surfaces:** Apply 1 liberal coat of Pretreatment-Wash Primer. Follow with sufficient coats of Vinyl Red Lead to yield dry film thickness of 6 mils. Then apply 2 coats Vinyl Boot-topping Black Paint to yield a total film thickness of 10 mils.

**Wood Surfaces:** Apply Black Vinyl Boot-topping Paint to dry wood previously treated with Wash Primer. If old coatings other than vinyl are on the surface, they must be removed completely. Firmly adhering vinyl paint can be painted. Apply 1 coat thinned by the addition of 1 pt. of Vinyl Thinner to 1 gal. of Vinyl Boot-topping Paint. Follow with 2 coats of paint as received.

**Plastic Surfaces:** Apply a liberal coat of Pretreatment-Wash Primer. Apply 1 coat of Black Vinyl Boot-topping Paint.

Additional instructions on spraying, brushing, drying, thinning, precautions regarding safety are outlined in Article 4-3-17.

#### SPECIFIC APPLICATION INSTRUCTIONS

Article 2-3-3(B), Steel Vessels in Salt Water — Vinyl System

#### ORDERING INFORMATION

Description: Black Vinyl Boot-top Antifouling Paint

Specification: MIL-P-16189, BuShips Formula 129

Color	Size Container	Stock Number
Black	5 gal.	FSS8010-290-4247
	1 gal.	CG8010-753-4945

#### 4-3-15, COLD PLASTIC ANTIFOULING PAINT, FORMULA 146/50

USE: As boot-topping paint on steel hulls of vessels in salt water.

#### GENERAL APPLICATION INSTRUCTIONS

Mixing: In all antifouling paints the cuprous oxide pigment is heavy and has a tendency to settle. Thorough mixing is necessary before use and constant agitation during use is imperative. This paint has a tendency to thicken

upon standing and it may appear that thinning is necessary for spraying. However, such dilution is not generally required. The paint should be agitated until it reaches spraying consistency. This will require at least 15 minutes of mixing time with a propeller type mechanical mixer. In cold weather store paint in a warm room for 24 hours before use.

Application: Spraying is the preferred method, although brushing is permissible. Apply 3 coats over surface previously coated with anticorrosive paint.

Drying: Allow 2 hours drying time between coats and 4 hours after last coat before undocking.

Thinning: This paint is of spraying consistency as received. If necessary, thin with Coal Tar Naphtha.

#### SPECIFIC APPLICATION INSTRUCTIONS

Article 2-3-3(A), Boot-top Painting, Steel Vessels in Salt Water — Cold Plastic System

#### ORDERING INFORMATION

Description: Cold Plastic Antifouling Paint

Specification: MIL-P-19449 (Ships), Formula No. 146/50

Color	Size Container	Stock Number
Black	5 gal.	FSS8010-290-8698

#### 4-3-16, COLD PLASTIC ANTIFOULING PAINT, FORMULA 105

USE: As an antifouling bottom paint on steel hulls in salt water.

#### GENERAL APPLICATION INSTRUCTIONS

Mixing: In all antifouling paints the pigment (cuprous oxide) is heavy and has a tendency to settle. Thorough mixing is necessary before use and constant agitation during use is imperative. This paint has a tendency to thicken upon standing and it may appear that thinning is necessary for spraying. However, such dilution is not generally required. The paint should be mixed until it reaches spraying consistency. This will require at least 15 minutes mixing time with a propeller type mechanical mixer. In cold weather, store paint in a warm room for 24 hours before use.

**Application:** Spraying is the preferred method although brushing is permissible. Apply 3 coats over properly primed surface.

**Drying:** Allow 2 hours drying time between coats and 4 hours after last coat before undocking.

**Thinning:** This paint is of spraying consistency as received. If necessary in cold weather thin with Coal Tar Naphtha.

#### SPECIAL APPLICATION INSTRUCTIONS

Article 2-3-2(B), Bottom Painting,  
Cold Plastic System

#### ORDERING INFORMATION

Description: Cold Plastic Antifouling Paint

Specification: MIL. SPEC. MIL-P-19451

Formula 105

<i>Color</i>	<i>Size Container</i>	<i>Stock Number</i>
Red	5 gal.	FSS8010-290-6651
	1 gal.	CG8010-721-9382

#### 4-3-17, VINYL ANTIFOULING PAINT

**USE:** As an antifouling paint for the bottom of wood, steel and plastic vessels and the underwater areas of steel and wood buoys.

#### GENERAL APPLICATION INSTRUCTIONS

This paint may be applied at any temperature above 5° F. The surface must be dry. It may be applied over well-adhering vinyl paint but not over old conventional paint. This paint should never be applied to bare unprimed metal as galvanic corrosion may result. Upon immersion in salt water the reddish brown color usually undergoes a gradual change to various shades of blue and green. This paint should not be used on the interior of water tanks or on roofs due to the high copper content of the paint.

**Metal Surfaces:** Apply 1 liberal coat (0.5 mil dry film thickness) of Pretreatment-Wash Primer. Prime surface with sufficient coats (usually 4 coats) of Vinyl Red Lead to give a dry film thickness of 6.0 mils. Follow with sufficient coats (usually 2 coats) of Vinyl Antifouling Paint to give a dry film thickness of 3.5 mils and a total dry film thickness of 10.0 mils for the system. Care should be

exercised to produce a smooth, non-pebbly finished appearance.

**Wood Surfaces:** Apply Vinyl Antifouling Paint to dry wood previously treated with wood preservative and wash primer. If old coatings are other than vinyl paints they must be completely removed. Vinyl Antifouling may be applied over old, firmly adhering vinyl paint. Apply 1 coat thinned by the addition of 1 pt. of thinner per gal. of paint. Follow with 2 coats of the paint as received.

**Plastic Surfaces:** Apply 1 liberal coat of Pretreatment-Wash Primer. Follow with 2 coats of Vinyl Antifouling Paint.

**Spraying:** This paint is designed for spray application. Because of rapid solvent evaporation, the spray gun must be kept within 8 to 10 in. of the work. The objective is to get a paint film that looks wet. Air pressure should be at least 40 psi above the liquid pressure. Each coat should consist of a vertical and a horizontal pass of the spray gun over each area. Special care is needed to insure that spray equipment is thoroughly clean before using this paint, since solvents used will dislodge hardened particles of conventional paints, causing the spray gun to clog frequently. Spray equipment should be cleaned with Vinyl Paint Thinner. Before use, charge equipment with Vinyl Paint Thinner and operate gun until all paint particles are cleared from the lines. Clean equipment immediately after use with Vinyl Paint Thinner.

**Brushing:** This paint is designed for spray application. However, it may be brushed on if applied properly. Take a full brush and spread it on without attempting to brush it out as with conventional paints. Due to the quick drying properties of this paint, do not attempt to cross work more than once. Stir paint frequently to prevent the cuprous oxide pigment from settling.

**Drying:** Dries for recoating in 30 minutes at temperatures above 60° F. Lower temperatures may require slightly longer drying time.

**Thinning:** This paint is of spraying consistency as received. Since solvent evaporates rapidly, thinner may be required after the can has been open for some time. In very cold weather, store paint in a warm place 24 hours before using. Thinner may be required to reduce viscosity in cold weather.

#### 4-3-17

The proper thinner is Vinyl Paint Thinner. Do not attempt to use other thinners in this paint.

**PRECAUTIONS:** In mixing or using this paint in an enclosed area, particular attention should be given to the air temperature in the vicinity of application. If the air temperature is below the flash point of the paint (40° F.), the material can be applied with normal ventilation. When the air temperature is above that of the flash point, sufficient ventilation must be provided to insure that the vapor concentration does not exceed the lower limits of explosibility. In addition, usual paint precautions to keep open flames and sparks away from the painting area and the area where paints are mixed must be strictly enforced. Like most paint materials in common use, adequate ventilation to avoid prolonged breathing of the concentrated paint fumes is necessary. Cans of this paint in storage should be turned over every 3 months to prevent hard settling.

#### SPECIFIC APPLICATION INSTRUCTIONS

Article 2-3-2(C), Bottom Painting,  
Vinyl System

Article 2-3-2(F), Bottom Painting,  
Wooden Boats

Article 2-4-1(B), Exterior of Metal Buoys,  
Below Waterline

#### ORDERING INFORMATION

Description: Vinyl Antifouling Paint

Specification: Purchase Description

FS-11-63, Amend-1, dated 29 Oct. 1963

*Color*      *Size Container*      *Stock Number*

Reddish Brown    1 gal.    CG8010-290-4075

5 gal.    CG8010-290-4076

#### 4-3-18, POLYISOBUTYLENE ANTIFOULING PAINT

**USE:** As an antifouling paint for use on rubber sonar domes and other rubber components subject to immersion in salt water. Contains polyisobutylene polymer, rosin, cuprous oxide, and solvents.

#### GENERAL APPLICATION INSTRUCTIONS

Apply 2 coats by spray of Antifouling Paint

over the previously applied primer-tie coat (Formula 133) MIL-P-22298.

#### SPECIFIC APPLICATION INSTRUCTIONS

Article 2-3-26(D), Painting of Rubber  
Surfaces of Sonar Domes and the  
Diaphragms of Sound Transducers

#### ORDERING INFORMATION

Description: Paint, Antifouling,  
Polyisobutylene

Specification: MIL-P-22299 (Ships),  
Formula 134

*Size Container*

1 gal.

*Stock Number*

FSS8010-823-7911

#### 4-3-19, RUBBER TIE-COAT FOR SONAR DOMES

**USE:** For use on rubber surfaces and surfaces coated with rubber cement. Serves as a primer tie-coat for the subsequent Antifouling Paint, Formula 134.

#### GENERAL APPLICATION INSTRUCTIONS

Apply 2 coats by spray of Rubber Tie-Coat (Formula 133) to the properly prepared surface.

#### SPECIFIC APPLICATION INSTRUCTIONS

Article 2-3-26(D), Painting of Rubber  
Surfaces of Sonar Domes and the  
Diaphragms of Sound Transducers

#### ORDERING INFORMATION

Description: Black Polyisobutylene Coating  
Tie-Coat

Specification: MIL-P-22298 (Ships),  
Formula 133

*Size Container*

1 gal.

*Stock Number*

FSS8010-823-7910

#### 4-3-20, ALUMINUM PAINT (READY-MIXED)

**USE:** For sealing creosoted or stained surfaces and knot and resin pockets in wood prior to the application of color coats. Not a heat-resistant paint. For surface above 300° F. use Heat-Resisting Aluminum Paint.



## GENERAL APPLICATION INSTRUCTIONS

Creosoted or Stained Wood: Allow newly creosoted wood to age 6 months. Remove all dirt and oil from the surface. Apply 2 coats of paint as received. Brush in 1 direction only to improve leafing.

Knots and Resin Pockets: Scrape excess resin and smooth the surface. Apply 1 coat of paint as received to resinous areas.

Drying: Sets to touch in 2 hours and dries hard for recoating in 16 hours.

Thinning: This paint is of brushing consistency as received. For spraying, thin as necessary with Paint Thinner.

CAUTION: The stability or shelf-life of this paint is less than that of most paints. Do not overstock. Overage paint loses its "leafing" properties.

## SPECIFIC APPLICATION INSTRUCTIONS

Article 2-2-1(A), Exterior Wood, General

Article 2-2-1(B), Exterior Floors, Decks,  
Steps, Bleachers

Article 2-2-1(E), Creosoted Wood

Article 2-2-1(F), Previously Stained Wood  
Shingles and Siding

Article 2-2-1(H), Interior Wood Trim

Article 2-2-1(I), Interior Wood Floors

Article 2-2-5(A), Wood Roofs

## ORDERING INFORMATION

Description: Ready-Mixed Aluminum Paint  
Specification: TT-P-38

<i>Size Container</i>	<i>Stock Number</i>
1 qt.	CG8010-290-7288
1 gal.	CG8010-290-7289

## 4-3-21, HEAT-RESISTING ALUMINUM PAINT (READY-MIXED)

USE: As a primer and finish coat on heated surfaces such as boiler drums and casings, steam lines, turbines and other steam machinery which are subjected to temperatures up to 1200° F. This is a ready-mixed paint containing silicone resin and aluminum pigment. For sealing creosoted or resinous wood use Ready-Mixed Aluminum Paint.

## GENERAL APPLICATION INSTRUCTIONS

Continued stirring is suggested to keep the

pigment from settling. Apply directly to the metal while the surface is cold.

Drying: Allow 8 hours between coats and 8 hours after last coat before subjecting the surface to high temperatures.

Thinning: Normally, this paint will not need thinning. If thinning is necessary, thin with Paint Thinner.

## SPECIFIC APPLICATION INSTRUCTIONS

Article 2-2-2(K), Hot Surfaces

Article 2-3-14(A), Interior Piping

Article 2-3-15(A), Interior Machinery

Article 2-3-24, Smoke Stacks

## ORDERING INFORMATION

Description: Heat-Resisting Paint (1200° F.)  
Specification: MIL-P-14276

<i>Size Container</i>	<i>Stock Number</i>
1 gal.	FSS8010-815-2692

## 4-3-22, TRAFFIC PAINT

USE: For traffic lines and safety zone markings on concrete, brick or asphalt pavement. Do not procure more than 6 months' supply because of settling tendencies of the paint.

## GENERAL APPLICATION INSTRUCTIONS

Apply directly to dry, clean pavement.

Drying: Sets to touch in 5 to 30 minutes. Dries hard in 1 hour at temperatures between 70° and 80° F.

Thinning: This paint is of brushing consistency as received. For application by paint stripping machines, thin as necessary with Paint Thinner.

## SPECIFIC APPLICATION INSTRUCTIONS

Article 2-2-9, Road and Runway Markings

## ORDERING INFORMATION

Description: Traffic Paint  
Specification: Federal TT-P-115

<i>Color</i>	<i>Size Container</i>	<i>Stock Number</i>
White	1 gal.	FSS8010-286-9074
Yellow	1 gal.	FSS8010-286-9076
Black	1 gal.	FSS8010-286-9072

#### 4-3-25

#### 4-3-23, ZINC DUST PIGMENTED ENAMEL

USE: For use on the interior of steel drinking water and feed water tanks.

#### GENERAL APPLICATION INSTRUCTIONS

This paint is issued as a two-package unit; 55½ lbs. of dry zinc dust and 5 gals. of the base paint comprise 1 unit. Mix as follows:

To 1 gal. of the liquid portion, the zinc dust shall be added in increments of 2½ to 5 lbs., and the mixture stirred with a paddle until no lumps or dry particles of zinc dust remain. The remaining 4 gals. of liquid shall be added in amounts of ½ gal. and stirring continued after each addition until the mixture is homogeneous. Zinc dust shall not be mixed with the liquid portion until just before application. Only enough paint shall be mixed for immediate use.

*Mixed paint shall not be stored.* (After the material is mixed, a gas pressure may build up within closed containers.)

Zinc Dust Paint shall be applied to conformance with the following instructions:

The tank shall be thoroughly cleaned of all oil paint coatings. (In new construction it is especially important to remove entirely the Zinc Chromate After-Pickling Paint in drinking water tanks.) Removal of the old paint coatings should be done by sandblasting if practicable. A power wirebrush may be used. Apply 1 coat of Zinc Dust Paint. Unheated air shall then be circulated through the tank for 12 hours and a second coat applied. Unheated air shall again be circulated for 12 hours. Tanks shall be flushed twice with fresh water before being placed in service.

Drying: Sets to touch in 3 minutes and dries hard for recoating in 12 hours.

#### SPECIFIC APPLICATION INSTRUCTIONS

Article 2-2-2(L), Steel Water Tanks (Interior Surfaces)

Article 2-3-7, Water Tanks

#### ORDERING INFORMATION

Description: Water Resisting Enamel, Zinc Dust Pigmented

Specification: MIL-E-15145

Base Paint 5 gal. pail FSS8010-290-6645  
and Zinc Dust 55½ lb. pail

#### 4-3-24, ANTISWEAT-COATING BINDER, FIRE RETARDANT

USE: As a binder for Expanded Vermiculite Pigment to provide antisweat protection on piping and bulkheads subject to condensation. GENERAL APPLICATION

#### INSTRUCTIONS

Apply 1 liberal coat of Pretreatment-Wash Primer and 2 coats of Quick Drying Red Lead Primer. Follow with 1 liberal coat of Antisweat-Coating Binder. Allow the Binder to become tacky and apply 1 coat of Expanded Vermiculite by flocking or by hand sprinkling. Follow with 2 coats of Interior Gloss Enamel.

Drying: Dry to touch within 2 hours. Dries hard for recoating in 8 hours.

Thinning: Thin as necessary with Paint Thinner.

#### SPECIFIC APPLICATION INSTRUCTIONS

Article 2-3-13, Spaces Subject to Heavy Condensation

#### ORDERING INFORMATION

Description: Enamel Fire-Retardant (Binder for Antisweat Coatings)

Specification: MIL-P-15144, Formula 34

Size Container

Stock Number

1 gal.

FSS8010-290-6646

#### 4-3-25, EXPANDED VERMICULITE

USE: In conjunction with Antisweat-Coating Binder as a coating to prevent condensation on walls and pipes. Light golden color similar to color of ground cork.

#### GENERAL APPLICATION

#### INSTRUCTIONS

Apply 1 liberal coat of Pretreatment-Wash Primer and 2 coats of Quick Drying Red Lead Primer. Follow with 1 liberal coat of Antisweat-Coating Binder. Allow the binder to become tacky and apply 1 coat of the Expanded Vermiculite by flocking or by hand sprinkling. Follow with 2 coats of Interior Gloss Enamel.

#### SPECIFIC APPLICATION

#### INSTRUCTIONS

Article 2-3-13, Spaces Subject to Heavy Condensation

#### ORDERING INFORMATION

Description: Expanded Vermiculite Pigment

Specification: MIL-V-15196

Procure on local purchase.

## SECTION 4-4, VARNISHES AND LACQUERS

### 4-4-1, SPAR VARNISH

USE: A high quality phenolic varnish suitable for general use. Meets almost all requirements of exterior and interior varnishes. May be used on brightwork to prevent corrosion. Has excellent durability in marine atmosphere and salt spray.

#### GENERAL APPLICATION INSTRUCTIONS

Apply the appropriate number of coats to clean, dry, bare wood or metal. Sand lightly between coats.

Drying: Sets to touch in  $\frac{1}{2}$  to 2 hours. Dries hard for recoating in 8 hours.

Thinning: Thinning not normally required. If necessary thin with Paint Thinner.

#### SPECIFIC APPLICATION INSTRUCTIONS

Article 2-2-7, Window and Door Screen Frames

Article 2-3-4(D), Exterior Aluminum

Article 2-3-4(E), Exterior Wood

Article 2-3-5(C), Interior Wood

Article 2-3-23, Wood Ladders, Gangplanks, Staging and Boatswain's Chairs

#### ORDERING INFORMATION

Description: Spar Varnish Phenolic

Specification: MIL-V-1174, Formula 80

Color	Size Container	Stock Number
Clear	1 qt.	FSS8010-234-5176
	1 gal.	FSS8010-166-1669

### 4-4-2, ELECTRICAL INSULATING VARNISH

USE: A black, insulating, air drying varnish for painting electrical windings and other parts of motors, generators, transformers, and electrical parts in general. Oil and water resistant. Baking varnishes and high temperature silicone varnishes are also available through Standard Stock to those shops which have baking ovens.

#### GENERAL APPLICATION INSTRUCTIONS

Apply to clean, bare metal or over clean, dry insulation or well-adhering old coatings of insulating varnish.

Drying: Dries hard for recoating in 8 hours.

Thinning: If necessary, thin with Paint Thinner.

#### ORDERING INFORMATION

Description: Electrical Insulating Varnish,

Grade BA, Air Drying

Specification: MIL-V-1137, Type AN

Color	Size Container	Stock Number
Black	1 gal.	9G5970-166-1675

### 4-4-3, ASPHALT VARNISH

USE: For painting anchor chain and chain lockers.

#### GENERAL APPLICATION INSTRUCTIONS

Apply 1 liberal coat of Pretreatment-Wash Primer. Follow with 1 coat of Asphalt Varnish.

Drying: Sets to touch in 3 hours. Dries hard in 24 hours.

Thinning: If necessary, thin with Paint Thinner.

#### SPECIFIC APPLICATION INSTRUCTIONS

Article 2-3-19, Anchor Chain

#### ORDERING INFORMATION

Description: Asphalt Varnish

Specification: Federal TT-V-51

Color	Size Container	Stock Number
Jet Black	1 gal.	FSS8010-299-0214
Jet Black	5 gal.	FSS8010-160-5856

### 4-4-4, SPRAYING LACQUER (FOR SHOP HELMETS)

USE: For applying color code to shop helmets. Designed for application by spray only. Will not lift undercoats.

#### GENERAL APPLICATION INSTRUCTIONS

Clean helmet and wipe with Lacquer Thinner

## ORDERING INFORMATION (Article 4-4-4)

Description: Spraying Lacquer, (Shop Helmets), Pigmented, Type II  
Specification: Federal TT-L-58

<i>Coast Guard Color</i>	<i>Federal Color No.</i>	<i>Size Container</i>	<i>Stock Number</i>
No. 13 Fire Red	11105	1 gal. can	FSS8010-577-4524
No. 14 Brilliant Yellow	13538	1 gal. can	FSS8010-527-2624
No. 16 Bright Green	14260	1 gal. can	FSS8010-616-7503
No. 18 International Orange	12197	1 pt. can	FSS8010-161-5723
White	17875	1 qt. can	FSS8010-165-6140
Black	17038	1 gal. can	FSS8010-584-3090

to remove all traces of grease and oil. Apply 2 coats of the Lacquer by spray. Do not attempt to brush the Lacquer.

Drying: Dries tack-free within 10 minutes. Dries hard in 24 hours.

Thinning: Thinning is not normally needed. If found to be necessary, use Lacquer Thinner.

#### SPECIFIC APPLICATION INSTRUCTIONS

Article 3-21-1, Helmet Colors

#### 4-4-5, LACQUER, PRESSURIZED CONTAINER

USE: For aircraft repair and touch-up. Also for minor touch-up in difficult to reach metallic surfaces.

#### GENERAL APPLICATION INSTRUCTIONS

Apply over a clean, properly prepared surface. May lift conventional paints if not aged sufficiently. Apply with 50% overlap. Safety precautions should be observed since the solvents are flammable. Allow 4 hour interval before recoating.

#### 4-4-6, CLEAR BRUSHING LACQUER FOR BRIGHTWORK

USE: On brightwork to prevent corrosion and reduce labor expended in polishing. Not suitable for furniture finishing.

#### GENERAL APPLICATION INSTRUCTIONS

Polish brightwork. Wipe with a cloth damp-

ened in Lacquer Thinner. Apply 1 coat of Clear Brushing Lacquer. Old coatings of Lacquer may be removed by wiping with a cloth wetted with Lacquer Thinner.

Drying: Dries tack-free in 30 minutes.

Thinning: Thinning is not normally needed. Clean brushes and thin, if necessary, with Lacquer Thinner.

#### SPECIFIC APPLICATION INSTRUCTIONS

Article 2-2-12, Surfaces Not to be Painted

Article 2-3-27, Brightwork

Article 2-3-29, Surfaces Not to be Painted

#### ORDERING INFORMATION

Description: Brushing Lacquer for Copper and Brass

Specification: TT-L-26

<i>Size Container</i>	<i>Stock Number</i>
1 qt.	FSS8010-166-1688
1 pt.	FSS8010-166-1703

#### 4-4-7, CLEAR ACRYLIC COATING

USE: As a water-clear protective coating on brightwork. For waterproofing ignition systems, shipping tags, and shipping and package labels. For weatherproofing stencils on shipping containers, maps, drawings, etc.

#### GENERAL APPLICATION INSTRUCTIONS

This material is furnished in a pressurized dispenser of the aerosol type. A transparent, nonflammable liquid for spray application at

room temperature. Resistant to water, alcohol, alkali, acids, oils, grease, and discoloration at high temperatures. Apply wet coats.

Drying: Dries hard for recoating in 1 to 2 minutes.

#### SPECIFIC APPLICATION INSTRUCTIONS

Article 2-3-27, Brightwork

#### ORDERING INFORMATION

Description: Spray-type Clear Acrylic Coating

Specification: MIL-C-12599

<i>Color</i>	<i>Size Container</i>	<i>Stock Number</i>
Clear	12 oz. can (Spray Dis- penser)	FSS8030-264-3837

---

#### ORDERING INFORMATION (Article 4-4-5)

Description: High Gloss Lacquer in Pressurized Container, Type I,

Nitrocellulose, Pigmented; packaged in 16 oz. can

Specification: Federal TT-L-0050, Type I

<i>Color</i>	<i>Federal Color No.</i>	<i>Stock Number</i>
Black	17038	FSS8010-290-6984
Blue (Dark)	15080	FSS8010-721-9747
Gray (Dark)	16099	FSS8010-141-2958
Green (Dark)	14062	FSS8010-141-2951
Green	14110	FSS8010-721-9483
Olive Drab	14064	FSS8010-584-3149
Orange International	12197	FSS8010-584-3148
Red (Bright)	11136	FSS8010-141-2952
White	17875	FSS8010-290-6983
Yellow (Brilliant)	13655	FSS8010-141-2950
Yellow (Orange)	13538	FSS8010-721-9744
Silver (Aluminum, Type 2)	17178	FSS8010-721-9751

---

## SECTION 4-5, THINNERS

### 4-5-1, PAINT THINNER

USE: A general purpose paint thinner suitable for thinning of most Coast Guard conventional paints with the exception of those few which require thinners of higher solvent power. The correct thinner is specified for each paint listed in this Chapter. Paint Thinner may also be used for cleaning oil, grease, and wax from surfaces preparatory to painting.

#### GENERAL INSTRUCTIONS

This thinner is composed of volatile mineral spirits or petroleum spirits having a flash point not under 100° F. Clean brushes and spray equipment with the thinner specified for the paint in which the equipment was used. Where a thinner of higher solvent power is desired, use Synthetic-Enamel Thinner.

#### ORDERING INFORMATION

Description: Thinner, Paint, Mineral Spirits  
Specification: Federal TT-T-291, Grade 1

<i>Size Container</i>	<i>Stock Number</i>
1 gal.	FSS8010-242-2089
5 gal.	FSS8010-558-7026

### 4-5-2, SYNTHETIC-ENAMEL THINNER

USE: A thinner containing 45-60% aromatic hydrocarbons for synthetic resin base paints and enamels which require a thinner of higher solvent power than Paint Thinner. May be used as a substitute for Paint Thinner, to avoid delaying a job in case Paint Thinner is not readily available.

#### GENERAL INSTRUCTIONS

This thinner is composed of aromatic hydrocarbons, is of intermediate solvent power and has a flash point not under 80° F. Use this thinner in Exterior Gloss Enamel when thinning excess of 1 part thinner to 4 parts enamel.

Paint Thinner is compatible with Exterior Gloss Enamel up to 1 part thinner in 4 parts enamel.

#### ORDERING INFORMATION

Description: Synthetic Resin Enamel Thinner  
Specification: Federal TT-T-306

<i>Size Container</i>	<i>Stock Number</i>
1 pt.	FSS8010-160-5791
1 gal.	FSS8010-160-5794

### 4-5-3, VINYL PAINT THINNER

USE: For thinning vinyl type paints and for cleaning brushes, spray guns, and equipment used in vinyl paints.

#### GENERAL INSTRUCTIONS

A clear thinner consisting of equal parts by weight of toluene and methyl isobutyl ketone (MIBK). High solvent power. Rapid drying. Not suitable for thinning Pretreatment-Wash Primer.

CAUTION: Flammable. Keep away from heat and open flames. Avoid prolonged breathing of vapors. Provide adequate ventilation.

#### ORDERING INFORMATION

Description: Vinyl Paint Thinner  
Specification: MIL-T-19588(CG)

<i>Size Container</i>	<i>Stock Number</i>
1 qt.	CG6810-286-0459
1 gal.	CG6810-286-2285
5 gal.	CG6810-286-0458

### 4-5-4, LACQUER THINNER

USE: For thinning spraying or brushing lacquers, clear or pigmented. For removing old coatings of clear lacquer from brightwork.

#### GENERAL INFORMATION

Composed of butyl and ethyl acetate, butyl and ethyl alcohol and petroleum naphtha. Ketones such as methyl ethyl ketone may be present to a maximum of 10%.

CAUTION: Highly flammable. Keep away from heat and open flames. Avoid prolonged breathing of vapors. Provide adequate ventilation.

## ORDERING INFORMATION

Description: Dope and Lacquer Thinner

Specification: TT-T-266

<i>Size Container</i>	<i>Stock Number</i>
1 pt.	FSS8010-160-5786
1 qt.	FSS8010-165-5540
1 gal.	FSS8010-160-5787

**4-5-5, COAL TAR NAPHTHA**

USE: As a thinner for Cold Plastic Antifouling Paints. For cleaning brushes and spray equipment.

## GENERAL INSTRUCTIONS

Cold Plastic Antifouling Paints do not normally need to be thinned. Thorough mixing will usually bring the material to spraying consistency. In cold weather store paint in a warm room for 24 hours before using. This is a noncorrosive, high solvent power thinner. It has a flash point not under 110° F. If thinning becomes necessary, use only the minimum amount necessary to restore spraying consistency.

## ORDERING INFORMATION

Description: Naphtha, Coal Tar

Specification: MIL-N-15178

<i>Size Container</i>	<i>Stock Number</i>
5 gal.	9W6810-244-1210
50 gal. drum	9W6810-244-1211

**4-5-6, BOILED LINSEED OIL**

USE: Used primarily to thin priming coats. For wood surfaces.

GENERAL APPLICATION  
INSTRUCTIONS

For diluting paint, follow directions specified in applicable painting system.

Drying: Slow drying. Dries hard for recoating in 18 hours.

CAUTION: Dispose of all rags soaked with Linseed Oil as soon as possible after using. Do not allow oil or paint soaked rags to accumulate. Linseed Oil dries by an oxidation and polymerization chemical reaction which gives off heat resulting in spontaneous combustion if confined and not allowed to dissipate.

SPECIFIC APPLICATION  
INSTRUCTIONS

Article 2-2-1(B), Exterior Floors, Decks, Steps, Bleachers

Article 2-2-1(D), Wood Decks, Wharves, Piers, Ramps

Article 2-2-1(I), Interior Wood Floors

Article 2-2-1(L), Wood Windows and Doors

Article 2-2-12, Surfaces Not to be Painted

Article 2-3-4(E), Exterior Wood

Article 2-3-5(C), Interior Wood

Article 2-3-23, Wood Ladders, Gangplanks, Staging and Boatswain's Chairs

Article 2-3-29, Surfaces Not to be Painted

## ORDERING INFORMATION

Description: Linseed Oil, Boiled

Specification: TT-L-190

<i>Size Container</i>	<i>Stock Number</i>
1 gal.	FSS8010-152-3245
5 gal.	FSS8010-684-8789

## SECTION 4-6, COMPOUNDS AND CEMENTS

### 4-6-1, WHITE PUTTY

USE: To fill seams, dents, and holes in wood.

#### GENERAL APPLICATION

##### INSTRUCTIONS

Consists of linseed oil, whiting, and white lead. Work excess linseed oil into putty by kneading. Fill holes, seams, etc. after priming coat has dried. If putty is applied to unprimed wood, linseed oil in the putty will be absorbed by the wood, the putty will dry chalky, crack and fall out. Paint over putty as soon as a firm skin is formed on the surface.

Drying: Surface skin forms in 3 to 10 days, depending on exposure and weather conditions. Do not paint over fresh putty as the paint will not dry.

Thinning: Boiled linseed oil may be added if necessary.

#### SPECIFIC APPLICATION

##### INSTRUCTIONS

Article 1-5-4, Preparation of Wood Surfaces

#### ORDERING INFORMATION

Description: White Linseed Oil Putty

Specification: TT-P-791, Type II

Color	Size Container	Stock Number
White	1 pt. can	FSS8030-753-5011
	1 qt. can	FSS8030-753-5012

### 4-6-2, CALKING COMPOUND FOR WOODEN VESSELS

USE: As a durable compound for filling exterior hull seams of wooden vessels. For gun application.

#### GENERAL APPLICATION

##### INSTRUCTIONS

Calk seams with oakum. Soak seams and oakum with Copper Naphthenate Wood Preservative. After the Preservative has dried, pay seams with Calking Compound. Finish seams with a hollow or concave surface to prevent forcing the compound out of the seams when the planking swells.

Drying: May be painted over after 24 hours.

#### SPECIFIC APPLICATION

##### INSTRUCTIONS

Article 1-5-4(E), Calking Wooden Boats

Article 2-3-1(B), Wooden Boats and Decks

Article 2-3-22, Wood Masts and Spars

#### ORDERING INFORMATION

Description: Calking Compound for Wooden Vessels (Gun Application)

Specification: MIL-C-18969, Type I

Size Container

Stock Number

1/10 gal. cartridge

FSS8030-577-4740

### 4-6-3, CALKING COMPOUND FOR METAL SEAMS AND STEEL SASH

USE: Remains plastic. Corrosion-resistant and waterproof. Application at room temperature. Use on lightweight sheet metal and as a sealant. Also use for sealing air ports and window frames on vessels.

#### GENERAL APPLICATION

##### INSTRUCTIONS

Type I is designed for application by a hand-operated calking gun. Type II is knife grade only. Where wood is in contact with aluminum, apply 1 coat of Spar Varnish to the wood and allow it to dry before joining the faying surfaces. Whether the joint or seam is intended to be watertight or not, make the joint tight by calking from both sides. Label plates, regardless of material, to be installed on aluminum structures are to be embedded in Type II Compound.

#### SPECIFIC APPLICATION

##### INSTRUCTIONS

Article 2-2-2(C), Exterior Aluminum

Article 2-3-4(D), Exterior Aluminum

#### ORDERING INFORMATION

Description: Compound, Calking, for Metal Seams, Light Gray Color

Specification: MIL-C-18969

Size Container

Stock Number

Gun Application, Type I

1 gal. can

FSS8030-243-0956

Knife Application,

Type II, Class A

1 gal. can

FSS8030-550-8628



**4-6-4, PLASTIC CALKING COMPOUND**

USE: For sealing joints in masonry or wood buildings or joints between various combinations of structural materials such as wood and metal, masonry and wood, etc.

**GENERAL APPLICATION  
INSTRUCTIONS**

Apply to clean, dry surfaces. This material will not stain the surface and will give better service without the use of primers. Grade 1 is of a soft consistency that can be applied by hand gun. Grade 2 is for knife application and is about the consistency of glazing putty. Since Grade 1 shrinks considerably and sometimes wrinkles, Grade 2 is often used on the more conspicuous parts of buildings. Calking should not be attempted when the temperature is below 40° F. In cold weather (above 40° F.) the material may be softened by warming it in the container. Calking compounds usually undergo changes in consistency in the container and should not be kept in storage for a long period before use.

Drying: Remains plastic. A surface drying forms a skin which may be painted over 24 hours after application.

Thinning: No modification of the formulation is permitted. In cold weather (below 40° F.) the material may be softened by heating in the container.

**SPECIFIC APPLICATION  
INSTRUCTIONS**

Article 1-5-4(F), Calking Cracks on Buildings

Article 1-5-5(D), Sealing and Waterproofing the Surface, Masonry

**ORDERING INFORMATION**

Description: Plastic Calking Compound  
Specification: Federal TT-C-598

Color	Size Container	Stock Number
	Grade 1, For Gun Application	
Gray	1 gal. can	FSS8030-243-0948
	Grade 2, For Knife Application	
Gray	1 gal. can	FSS8030-243-0946

**4-6-5, PLASTIC WOOD**

USE: For filling holes, cracks and other

defects in wood. For building up or filling in parts of wood pattern or joiner work.

**GENERAL APPLICATION  
INSTRUCTIONS**

This material is light in color and may be stained while plastic to match dark colored woods. It cannot be stained after it has hardened. Apply with a putty knife and leave a slight excess on the surface to compensate for shrinkage. After setting, sand smooth. Adheres to wood or metal. The Solvent Fluid is suitable for softening the Plastic Wood after it has hardened. Plastic Wood may be cut, sawed, bored, reamed, or filled when dry and will hold nails.

Drying: Sets quickly. Hardens for working in 4 hours.

Thinning: Soften when necessary with Plastic Wood Fluid Solvent. Keep lid tightly sealed, to avoid loss of solvent.

**SPECIFIC APPLICATION  
INSTRUCTIONS**

Article 1-5-4(A), Preparation of Wood Surfaces, Bare Wood

Article 2-2-1(J), Furniture Finishing

**ORDERING INFORMATION**

Description: Plastic Wood Filler

Specification: TT-F-340

Size Container	Stock Number
4 oz. can	FSS8010-262-9171
1 lb. can	FSS8010-262-9172

**4-6-6, MARINE GLUE**

USE: For waterproofing wooden deck seams on boats.

**GENERAL APPLICATION  
INSTRUCTIONS**

Preparing the Seams: Clean seams out thoroughly and remove all traces of pitch, putty, resin or other seam compositions. Calk the seams carefully, leaving about 1/2 in. space above the calking for the Marine Glue. Calking irons should be dipped in water, coal oil, or other volatile fluid and not in linseed oil or grease, as these will prevent the glue from adhering to the planking.

Preparing the Glue: Melt the glue slowly in cast iron or heavy sheet iron pots or elec-

#### 4-6-8

trically heated glue pots. It should be heated to approximately 300° F. or until it becomes entirely fluid. Do not heat the glue to its boiling point of 350° F. When properly melted, it should drip like oil without stringing out. It should be used as promptly as possible in this consistency.

**Applying the Glue:** Pour the glue into the clean dry seams from a paying shell or ladle with a spout issuing a fine stream. The spout should be held about 1 in. away from the seam to allow air to escape; it should not be drawn on the seams as this permits air to be enveloped which cannot escape and the resultant air pockets leave the seams hollow and unsound. Apply the glue in 2 operations; the first filling to consist of a small quantity payed into the bottom of the seam and allowed to set before applying the second one. Allow the glue to overflow the seams slightly, permitting the excess to remain for several days. Remove the excess by scraping diagonally across the seam. In hot weather, when the glue is soft, application of water to the deck will facilitate scraping. Leave the glue flush with the deck.

**Drying:** Sets upon cooling.

**Thinning:** Altering the formulation of Marine Glue by the addition of solvents is not permitted.

#### SPECIFIC APPLICATION INSTRUCTIONS

Article 2-3-1(B), Wooden Boats and Decks

#### ORDERING INFORMATION

Description: Marine Glue

Specification: MIL-G-413, Class 2

Color	Size Container	Stock Number
-------	----------------	--------------

Jet Black	28 lb. box	FSS8030-174-2591
	250 lb. drum	FSS8030-174-2593

#### 4-6-7, SMOOTHING CEMENT FOR IRON OR STEEL

USE: For filling in rough or pitted iron or steel surfaces prior to painting.

#### GENERAL APPLICATION INSTRUCTIONS

Apply to clean dry metal. Mix cement thor-

oughly to obtain a smooth, uniform consistency. Apply with a putty knife, pressing the cement firmly into pits. Smooth off the surface while the cement is plastic. The surface may be sanded smooth after the cement has hardened.

**Drying:** Sets to touch in ½ to 2 hours. Dries hard in 24 hours.

**Thinning:** May be thinned, if necessary, with Paint Thinner.

#### SPECIFIC APPLICATION INSTRUCTIONS

Article 2-2-2(H), Machinery, Shore Units

Article 2-3-15, Machinery, Shipboard

#### ORDERING INFORMATION

Description: Smoothing Cement

Specification: MIL-C-15202, Formula No. 62

Size Container	Stock Number
----------------	--------------

1 gal.	FSS8010-227-1698
To be discontinued	

#### 4-6-8, HYDRAULIC CEMENT FOR IRON OR STEEL

USE: For closing minor defects such as surface porosity in castings; not to be used for sealing cracks or hot tears.

#### GENERAL APPLICATION INSTRUCTIONS

Clean the crack or pit thoroughly by wire-brushing. Press the cement into the opening firmly. This compound will not chip or break out when the work is sawed or filed. It will stand quenching in 60° F. water from 1500° F. without separating from the metal to which it is applied.

**Drying:** Allow the cement to dry for 24 hours at normal air temperature before placing in service.

**Thinning:** Mix with water.

#### ORDERING INFORMATION

Description: Hydraulic Cement for Iron or Steel

Specification: MIL-C-1219, Class B

Size Container	Stock Number
----------------	--------------

5 lb. can	FSS8030-250-4666
-----------	------------------

## SECTION 4-7, MISCELLANEOUS MATERIALS

### 4-7-1, WET-SANDBLASTING CHEMICALS

USE: As a rust inhibitor solution in wet sandblasting slurry and in the final wash.

#### GENERAL APPLICATION INSTRUCTIONS

Slurry: A 4 to 1 mixture of Diammonium Phosphate and Sodium Nitrate shall be used as follows: Add 2 lbs. of the mixture (fill a qt. can 4/5 full with Diammonium Phosphate and then to the top with Sodium Nitrate) to 15 gals. of water and 300 lbs. of sand in the sandblasting unit.

Final Wash: In the final operation of washing down the sand from the blasted area, 2 lbs. of the mixture are added to 40 gals. of water to make up the rust inhibiting wash.

CAUTION: Since this solution decomposes to form gases on standing, stock solutions of the inhibitor shall not be employed.

#### SPECIFIC APPLICATION INSTRUCTIONS

Article 1-5-1, Preparation of Metallic Surfaces (Except Aluminum and Galvanized Steel)

#### ORDERING INFORMATION

Description: Diammonium Phosphate  
Formula:  $(\text{NH}_4)_2\text{HPO}_4$

<i>Form</i>	<i>Size Container</i>	<i>Stock Number</i>
White Powder	100 lb. bag	9W6810-174-1821

Description: Sodium Nitrate  
Formula:  $\text{NaNO}_2$

<i>Form</i>	<i>Size Container</i>	<i>Stock Number</i>
Yellowish Crystals	150 lb. bbl.	1H6505-180-9987

### 4-7-2, LIQUID FLOOR WAX

USE: As a protective coating on all types of floors, including asphalt and rubber. This is a water-emulsion-type floor wax. Will not attack asphalt tile. Also imparts slip resistance.

#### GENERAL APPLICATION INSTRUCTIONS

Apply in thin coats with a cloth or mop. Dries to a transparent, lustrous, and practically colorless film. Dries to a hard film in 20 minutes. Polishing is not necessary but a high gloss may be obtained by machine buffing.

CAUTION: Protect from freezing.

#### SPECIFIC APPLICATION INSTRUCTIONS

Article 2-2-1(I), Interior Wood Floors  
Article 2-2-12, Surfaces Not to be Painted  
Article 2-3-29, Surfaces Not to be Painted

#### ORDERING EQUIPMENT

Description: Water-Emulsion Floor Wax

Specification: P-W-155

<i>Size Container</i>	<i>Stock Number</i>
1 gal.	FSS7930-132-5584

### 4-7-3, AUTOMOBILE POLISH

USE: For polishing all vehicles which have lacquer, baked enamel, or synthetic enamel finishes.

#### GENERAL APPLICATION INSTRUCTIONS

A liquid polish containing an abrasive in suspension. Volatile portion is essentially water. Shake often while using to prevent settling of the abrasive.

CAUTION: Protect from freezing.

#### SPECIFIC APPLICATION INSTRUCTIONS

Section 2-5, Coating Systems For Vehicles

#### ORDERING INFORMATION

Description: Automobile Polish (Liquid)  
Specification: Federal P-P-546

<i>Size Container</i>	<i>Stock Number</i>
1 pt.	FSS7930-266-7141
1 qt.	FSS7930-266-7142

### 4-7-4, PAINT AND VARNISH REMOVER (ORGANIC SOLVENT TYPE)

USE: To remove old coatings of paint or varnish from metal or wood.

#### 4-7-6

### GENERAL APPLICATION INSTRUCTIONS

This remover is nonflammable. Apply with a full brush without brushing out. Do not break the wax film which forms on the surface. The wax retards evaporation and allows the remover to lift the paint. After the paint or varnish blisters, remove it with a broad putty knife. Wash the surface with Paint Thinner to remove any traces of Paint Remover before refinishing.

**CAUTION:** Volatiles may be toxic. Avoid prolonged breathing of vapors. Proper ventilation is imperative. Prevent evaporation as far as practicable during actual use of the material. Has a limited shelf life. Do not overstock.

### SPECIFIC APPLICATION INSTRUCTIONS

Article 1-5-2, Preparation of  
Aluminum Surfaces

Article 1-5-4(D), Use of Paint Remover

Article 2-2-1(J), Furniture Finishing

Article 2-2-3(E), Concrete Floors Both  
Above and Below Grade

### ORDERING INFORMATION

Description: Paint and Varnish Remover,  
Organic Solvent Type

Specification: Federal TT-R-251, Type III,  
For Horizontal Surfaces—Class A

<i>Size Container</i>	<i>Stock Number</i>
1 qt.	FSS8010-160-5799
1 gal.	FSS8010-597-8234

For Vertical Surfaces—Class B

*Size Container*

1 gal.

*Stock Number*

FSS8010-160-5800

#### 4-7-5, PAINT CLEANER

USE: A synthetic organic detergent for removing dirt and grease from painted surfaces with soft or hard water. Will not harm high gloss finish of automotive vehicles and construction equipment. Contains no abrasive or fatty acid soaps. NOT INTENDED FOR USE ON AIRCRAFT SURFACES.

### SPECIFIC APPLICATION INSTRUCTIONS

Article 1-5-4(B), Preparation of Wood  
Surfaces Previously Painted

Article 1-5-6, Cleaning Painted Surfaces

### ORDERING INFORMATION

Description: Painted-Surface Cleaner

Specification: Federal P-D-220a

<i>Form</i>	<i>Size Container</i>	<i>Stock Number</i>
Type II, Liquid Class	1 gal.	FSS7930-634-4784

#### 4-7-6, METAL POLISH

USE: Removes tarnish from brass, copper, bronze and other metals. Free of acids, potassium cyanide.

### ORDERING INFORMATION

Description: Metal Polish (Liquid)

Specification: Federal P-P-556

<i>Form</i>	<i>Size Container</i>	<i>Stock Number</i>
Liquid	1 qt. can	FSS7930-269-1271

## SECTION 4-8, HEAVY DUTY COATINGS

### 4-8-1, EPOXY PROTECTIVE COATINGS (GENERAL)

USE: For use only in high maintenance areas where conventional coatings have proved difficult to maintain and where the necessary surface preparation can be accomplished. The use of these materials is justified and will be worthwhile only in those applications where proper surface preparation of less degree than commercial blast cleaning will be ineffective in providing the anticorrosive protection desired. At the present time the proprietary material marketed by Devco & Reynolds under the name "Devran" is authorized.

#### PREPARATION OF COATING

This is a 2 component coating and requires the proper mixing of the base component with a curing agent or convertor in the correct proportion. Only the amount of material which can be applied in half of the pot life should be mixed at one time. (Note that Formula 203 has a 4-hour pot life at 77°F.) Stir both base and convertor thoroughly, then combine and mix well. Do not use the convertor for 1 formulation with the base of another formulation, as this may impede proper curing. The coating may be applied immediately after mixing.

#### GENERAL APPLICATION INSTRUCTIONS

The epoxy coating should be applied to a properly prepared steel surface. This can be achieved by sandblasting to clean gray metal conforming to the Steel Structures Painting Council (SSPC), Specification 6-63, "Commercial Blast Cleaning" and should be cited in construction and repair specifications. It means complete removal of all mill scale. Gray mill scale binder may remain. Particular attention shall be given to all metal edges, rivet heads, and the undersides of structural members to insure that proper surface preparation has been obtained. The prime coat must be applied the same day the sandblasting is accomplished, and before the dew point has been reached. Allow 8 hours drying time to cover the prime coat and 16 hours for

succeeding coats. Some variation in drying times may be noticed. For example, Formula 209 will dry more quickly than this, and Formula 207 will require more time. Each coat should be free of solvent and hard to the fingernail before recoating.

Application may be by spray, brush, or roller. Spray application is more economical on large jobs but brush application is particularly desirable for the primer coat on heavily pitted surfaces, around rivets, and behind hard-to-get-at structures. Note: Clean brushes immediately after use or they may be permanently damaged.

(a) Epoxy coatings should not be applied with a surface temperature below 50° F. If necessary, artificial heat should be used, and the continuance of artificial heat after application will accelerate curing.

(b) Good housekeeping is important. Use special epoxy thinner to clean equipment thoroughly after use, before the material begins to cure. Make sure that all equipment is free of old material before use.

(c) While Devran may be subjected to light mechanical contact after drying hard to the touch, it must be completely cured before immersion in water, fuel, etc.

### 4-8-2, EPOXY SYSTEMS, SPECIFIC

Devran 203 System: Tank and bilge coating (except potable water tanks) consists of 202 Primer followed by 2 coats of Devran 203 in contrasting colors.

This system should be applied by spray yielding a total dry film thickness of 9 mils. Excessive film thickness must be avoided because of possible solvent entrapment.

Devran 209 System: A high performance color coat system consisting of 1 coat 202 Primer followed by 2 coats of 209. Devran 209, when applied by spray, requires heavy duty spray equipment and is applied at a rate of about 350 sq. ft. per gal. to yield a 2.0 mil film thickness.

Devran 209 may be used as a color coat over either Coal Tar Epoxy, Insulmastic 553 FR, Devran 203, or on plastic boats. In all

## 4-8-2

cases the base coat must be completely cured before application of the Devran in order to eliminate bleeding. Where the rate of cure is retarded, due to extended periods of low temperature, a tie-coat of Devran 210 should be applied. Base coat surfaces should be given a light solvent wipe before color coating, using MIBK or Vinyl Thinner. It may be found that 1 coat of Devran 209 is sufficient to hide the base coat.

Devran 202 may be used as a Primer under Coal Tar Epoxy, if time does not permit the immediate application of the Coal Tar Epoxy after surface preparation.

Devran 207 is a 2-component coating possessing excellent resistance to fresh water. Devran 207 is authorized as a potable water tank coating. On maintenance painting of tanks in service, the complete removal of any existing coatings must be accomplished. Three coats of contrasting colors are required, to a minimum dry film thickness of 6 mils. It is particularly important that 100% coverage be achieved in potable water tanks. Sterilization following coating is to be carried out in accordance with existing directives.

### SPECIFIC APPLICATION INSTRUCTIONS

- Article 2-2-2(J), Waterfront and  
Underground Metal Surfaces
- Article 2-2-2(L), Steel Water Tanks  
(Interior Surfaces)
- Article 2-3-7(B), Water Tanks,  
Epoxy Coating System

### ORDERING INFORMATION

Local procurement and/or specification in repair or construction contracts of these approved special coating systems is authorized at the discretion of the District Commander in applications where comparison with conventional systems indicates that the additional initial material, preparation, and application costs are justified. Devran authorized products not listed below may be purchased from the following supplier: Devoe & Raynolds Company, Inc., Delancy and Rutherford Street, Newark, N.J. 07105, or P.O. Box 188, Riverside, Cal. 92502. The following products are available as Coast Guard Stock Items:

Catalog Name: Epoxy Paint, "Devran" or Coast Guard approved equivalent.

Packaged in 1 gal. can (2 components)

Formula No.	Color	Stock Number
202	Buff	CG8010-G00-1193
209	Black	CG8010-G00-1192
209	White	CG8010-G00-1046
209	Marine Red	CG8010-G00-1047
209	Spar	CG8010-G00-1048
209	Deck Gray	CG8010-G00-1059
209	Light Gray	CG8010-G00-1060

## 4-8-3, COAL-TAR EPOXY COATINGS

USE: For use on underwater appendages, bilges, voids, hidden areas, off-shore fixed steel structures, dissimilar metal junctions, embedding material for hull anodes, underwater body and boot-topping areas. Close attention must be devoted to proper surface preparation, equipment used, and coating application for satisfactory performance. At the present time the proprietary coatings Tarsel, Amercoat 78, and Amercoat 79 are authorized.

### PREPARATION OF COATING

These coatings are supplied in 2 components. To prepare for use and before adding the container of curing agent or convertor, thoroughly agitate the container of Coal-Tar Epoxy using power mixer, if available. When thoroughly mixed, the Coal-Tar Epoxy breaks down into a thick jet black viscous liquid. Add curing agent with constant agitation. The quantity prepared should be limited to that which can be applied in 1 hour. Follow the manufacturer's directions explicitly.

### GENERAL APPLICATION INSTRUCTIONS

Apply the coating as soon after mixing as possible. If by brush, scoop the Coal-Tar Epoxy from the container and apply heavily in sweeping, overlapping strokes. Do not brush out to a thin film. If by roller, use one with a firm nap (rug type), not a lamb's wool type. If the work is stopped for 10 minutes or more, clean all tools with special Coal-Tar Epoxy Thinner. Otherwise, the material will set up and make cleaning impossible. *If by spray gun*, an 8:1 or higher ratio barrel pump must be used with a mastic gun having a 3/16 in. or 1/8 in. internal mixing nozzle. A 3/16 in. nozzle in the gun will permit application of

Coal-Tar Epoxy at approximately 10 gals. per hour, while a  $\frac{1}{8}$  in. nozzle affords a lower application rate but gives a smoother coating with fewer dimples. Air pressure of 85 psi at the pump and 100 psi at the gun is satisfactory. Satisfactory results can also be obtained with air pressure of 65 psi at the pump. Air pressure fluctuations should be limited to plus or minus 8 psi. A minimum  $\frac{3}{4}$  in. inside diameter material-hose should be used between the barrel pump and gun. The material-hose must be resistant to aromatic solvents. A minimum thickness of 16 mils is required on all surfaces to be coated. This should always be applied in 2 coats. Each coat should be about 8-10 mils thick, to provide this minimum (not average) thickness of 16 mils.

The first coat should be applied and allowed to dry, tack-free, before application of the second coat. In summer weather, a second coat can sometimes be applied about 4 hours after the first coat. If, for any reason, the first coat is left exposed in sunlight for 72 hours or more before application of the second coat, the surface should be lightly wire-brushed and wiped with methyl isobutyl ketone (MIBK) or Vinyl Paint Thinner before applying the second coat.

Whenever possible, the material should be applied without thinning. This will afford an 8-10 mil application on vertical surfaces without running, curtaining, or sagging. Where thinning must be done, it should be limited to a quantity of thinner not more than equivalent to the amount of catalyst added, i.e., not more than 6 oz. per gal. or as specified.

NOTE: See specific instructions from manufacturer on the proprietary product being applied.

#### COLD WEATHER APPLICATION

When the temperature is below that at which the application of Tarsol is usually recommended, the material can be applied and cured provided that external heat is applied to the surface. The use of heat under any conditions will accelerate the curing of the coating. The temperature of the surface to be coated should be at least 50° F.

#### SURFACE PREPARATION

Steel surfaces shall be prepared by sandblast-

ing to clean gray metal as defined in Steel Structures Painting Council (SSPC) Specification 6-63, "Commercial Blast Cleaning," which should be cited in construction and repair specifications. It means complete removal of all mill scale. Gray mill scale binder may remain. Surfaces must be completely free of moisture, soil, dust and grit. Wherever possible areas to be coated shall be sandblasted and coated immediately. In areas where it is not feasible, the use of Devran 202 Primer should be employed.

#### TOP COLOR COAT OVER COAL-TAR EPOXY

Where black or red is not satisfactory as a surface color, where it is exposed to direct sunlight, Coal-Tar Epoxy must be color coated. To prevent bleeding, the coating should be completely cured. Where a high performance color coat is desired, 2 coats of Devran 209 may be used, following a wipe-down with MIBK or Vinyl Paint Thinner. In areas where less wear is expected, Standard Alkyd Enamel (TT-E-489) may be used with similar wipedown. Colors should conform to the Paint and Color Manual where specified, except in voids and bilges completely masked from view.

#### ANTIFOULING COATING OVER COAL-TAR EPOXY

Both vinyl and cold plastic antifouling coatings have been satisfactorily used over Coal-Tar Epoxy. The Coal-Tar Epoxy should be allowed to cure, and wiped down with MIBK or Vinyl Paint Thinner before application of the antifouling paint.

#### DISSIMILAR METAL JUNCTIONS

Coal-Tar Epoxy may be applied over the joint between dissimilar metals to reduce galvanic corrosion. Coal-Tar Epoxy should be applied in 2 coats over a width of 6 in. on either side of the joint. Color coating may be obtained by use of Devran Formula 209 or Standard Alkyd Enamel, TT-E-489.

#### SPECIFIC APPLICATION INSTRUCTIONS

Article 2-2-2(J), Waterfront and  
Underground Metal Surfaces

### 4-8-3

Article 2-3-1(A), Protective Coatings for Construction and Maintenance, Steel Vessels

Article 2-3-2(D), Coal-Tar Epoxy System

Article 2-3-3(C), Steel Vessels, Coal-Tar Epoxy System

#### ORDERING INFORMATION

Catalog Name: Coal-Tar Epoxy Coating.

Tarset is manufactured by Pittsburgh Chemical Company, Protective Coatings Division, Pittsburgh, Pa. 15219.

Amercoat 78 and 79 are manufactured by Amercoat Corporation, Brea, Cal. 92621.

Specification: MIL-P-23236 (Ships), Class 2.

Tarset and Amercoat are approved and have qualified under QPL requirements.

Color	Size	Container	Stock Number
Black, tarset	1 gal.		CG8030-G00-1042
	5 gal.		CG8030-G00-1041
Red, tarset	1 gal.		CG8030-G00-1190
	5 gal.		CG8030-G00-1189

Amercoat 78 and Amercoat 79 are also approved and have qualified under QPL requirements of MIL-P-23236 (Ships) Class 2. Amercoat 78 (Amine cured), Black and Red color, Amercoat 79 (Amine cured), Black and Red color manufactured by the Amercoat Corporation, 201 North Berry Street, Brea, Cal. 92621, or 360 Carnegie Avenue, Kenilworth, N.J. 07033. These coatings should be mixed and applied in conformance to the Amercoat Corporation directions and are compatible with Tarset in maintenance work. Always use recommended curing agent for the brand being used.

### 4-8-4, HEAVY BODY MASTIC COATING

USE: For thermal insulation and anti-condensation.

DESCRIPTION OF MATERIAL: A fire retardant mastic compound of Gilsonite asphalt, cork, and mica. It is an effective antisweat coating and thermal insulator, and also provides corrosion protection. It has a rough surface texture, and requires a primer coat and color coats for appearances. In some cases it is a superior substitute for fiberglass blankets, cork or vermiculite. The product, "Insulmastic 553FR" meets the above description and is authorized for use.

#### SURFACE PREPARATION

Steel surfaces should be prepared by sand-blasting to clean gray metal free of moisture, soil, dust, and grit when the first coat is applied.

#### GENERAL APPLICATION INSTRUCTIONS

The steel surface should be treated with Wash Primer (Formula 117) MIL-C-15328, 1 coat of Zinc Chromate Alkyd Primer (Formula 84/47) TT-P-645, followed by one coat of Insulmastic 553FR applied  $\frac{1}{4}$  in. thick, followed by 2 coats of Devran 209 of the proper color. The latter should not be applied sooner than about 10 days after the application of the Insulmastic, in order to allow time for solvent evaporation. The use of the epoxy color coat produces a hard finish, making maintenance easier.

Insulmastic 553FR may be applied by either hot or cold spray as received. Thinning is not required. However, the material is heavy-bodied and therefore should be thoroughly mixed using a power mixer.

Spray application is preferred as this will give a less dense coating. Use an interior mix-mastic spray gun with a  $\frac{1}{4}$  in., 5/16 in., or  $\frac{3}{8}$  in. nozzle operated from an 8 to 1 ratio barrel pump driven by 105 cfm, 100 psi air compressor. A  $\frac{1}{4}$  in. nozzle is best when working at a distance from the pump. The first 15 ft. of hose from the gun may be  $\frac{3}{4}$  in. I.D. for ease of handling. The remainder should be  $1\frac{1}{4}$  in. I.D. The hose should be neoprene lined or solvent resistant, and should be 2400 psi tested.

Apply Insulmastic 553FR at a rate of about 5 sq. ft. per gal. to obtain a dry film thickness of 250 mils in 1 application. This thickness should also be applied if the special consistency type (for troweling only) is applied by trowel. Do not apply when surface temperatures to be coated are less than 50° F. During cold weather, surfaces to be coated can be heated to a temperature above 50° F. and application can be continued using the hot spray method. The surfaces coated and the surrounding area temperature should be above 50° F. until cure is complete. At 77° F. the material will dry tack-free in 24 hours. The material should be thoroughly cured



with a firm dry film in 3 to 10 days, depending on ambient temperature, humidity, and ventilation. Where drying conditions are adverse, 2 applications of 125 mils may be used, allowing time for the first to cure before application of the second coat. There will be some surface roughness due to the nature of the material, but no globs or deep depressions should be permitted. The Devran 209 color coat must not be applied until the Insulmastic has fully dried. This may be as much as 14 days under extremely unfavorable conditions. The material can be considered dry when the solvent odor has disappeared and the surface is firm to the fingernail. Give the Insulmastic surface a solvent wipe with Vinyl Thinner before Devran application.

#### SPECIFIC APPLICATION INSTRUCTIONS

Article 2-3-13, Spaces Subject to Heavy Condensation

#### ORDERING INFORMATION

Insulmastic 553FR may be purchased from the Pittsburgh Chemical Company, Protective Coatings Division, Grant Building, Pittsburgh, Pa. 15219. The cost of Insulmastic 553FR is \$1.62 per gal. f.o.b. Summit, Ill. in 5 gal. containers.

#### 4-8-5, INORGANIC ZINC SILICATE COATINGS

USE: As a primer and complete system over steel surfaces. Possesses high abrasion resistance and resists degradation due to sunlight. Can be used for the protection of buoy decks and may be topcoated with vinyl alkyd or epoxy. Expansion of usage will depend on results of tests now in progress. Limited data as an underwater body coating on ships operating in fresh water with corallary ice-breaking duties appears promising. This coating is supplied as a 2-package unit and is of the "post-curing" type. 1 gal. of the powder must be mixed with the quantity of liquid supplied in each gal. can, producing 1 gal. of the mixed coating. The mixture must be used within 4 hours after mixing.

#### GENERAL APPLICATION INSTRUCTIONS

The steel surfaces should be blasted to an even, gray-white color as defined by the Steel Structures Painting Council Standard No. 5. Blast Cleaning to White Metal. Pour powder portion slowly into the liquid while stirring. Do not mix in reverse order. Apply a heavy wet coat, overlapping each pass 50% to avoid thin spots. Do not apply over 5 mils. Rinse spray equipment with fresh water immediately after use.

Allow to air-dry until it becomes a light gray, then allow an additional hour minimum and apply the curing solution. For satisfactory curing, air temperature must be not lower than 20° F. After a lapse of 24 hours, wash off residue with fresh water. The coating is then ready for service.

Safety Note: Since curing solution is acidic, prolonged contact with the skin should be avoided. Should it be splashed on the face, wash immediately and thoroughly with fresh water.

#### SPECIFIC APPLICATION INSTRUCTIONS

Article 2-3-2(E), Bottom Painting,  
Inorganic Zinc Silicate

#### ORDERING INFORMATION

Until stock numbers are assigned, Zinc Silicate Coatings shall be procured on a local purchase basis.

The following post cure coatings have qualified under MIL-P-23236, Class 3, and are approved for Coast Guard service in the specific areas listed above.

DIMETCOTE #3, Amercoat Corp., Brea, Cal. 92621.

RUST-BAN #190/195, Humble Oil & Refining Co., Houston, Texas 77002.

CATHACAT #300, Devoe & Reynolds Co., Newark, N.J. 07105 or Riverside, Cal. 92502.

Touch up of worn areas may be achieved by using the self-curing type qualified under MIL-P-23236, Class 3.

## SECTION 4-9, PAINT SPRAY EQUIPMENT

### 4-9-1, TYPES OF EQUIPMENT, STANDARD STOCK

The following paint spray equipment is available from the sources indicated below.

(a) Paint spray outfit, lightweight, Type B, consisting of light duty touchup gun, pressure cup, air hose, air compressor, compressor motor and air pulsation tank or chamber (AC). (Mil. Spec. MIL-S-15297 Type B). Stock No. 1H4940-221-2446 (AC current).

(b) Paint spray outfit, Type A, consisting of heavy duty spray gun, 5 gal. pressure tank, 1 qt. pressure cup, two 25 ft. lengths material hose, two 25 ft. lengths air hose (Mil. Spec. MIL-S-15297 Type A). Stock No. GS4940-221-2447.

(c) 2 gal. pressure tank (Mil. Spec. MIL-S-15297 Type A). Stock No. 1H4940-251-6798.

(d) Heavy duty spray gun with removable 1 qt. pressure type cup with lid and 1 extra 1 qt. cup without lid (Mil. Spec. MIL-S-15297, Type A). Stock No. 1H4940-261-8415.

(e) Heavy duty spray gun with one 6 ft. extension handle and one 8 ft. extension handle (Mil. Spec. MIL-S-15297). Stock No. 1H4940-287-8800.

(f) 25 ft. length material hose with suitable fittings attached. Stock No. 9C4720-289-

3429 ( $\frac{3}{8}$  in. female coupling and male connector).

(g) 25 ft. lengths of air hose with suitable fittings attached. Stock No. 9C4720-289-4611 (female coupling and male connector), ( $\frac{1}{4}$  in. female,  $\frac{3}{8}$  in. male).

Replacement and spare parts for paint spray equipment are carried by Ships Parts Control Center, Naval Supply Depot, Mechanicsburg, Pennsylvania. When ordering parts for paint spray equipment (other than complete spray gun assemblies, pressure tanks and material and air hose), the manufacturer's part numbers as well as manufacturer's name and model number of equipment for which required, must be placed on the requisition or purchase order.

### 4-9-2, HOT SPRAY, AIRLESS

The following lists some sources of supply for hot spray and airless type equipment but should not be construed to indicate preference for equipment offered by these manufacturers or eliminate other sources of supply.

The De Vilbiss Co., Toledo, Ohio 43601

The Gray Co., Inc., Minneapolis, Minn. 55413

The Spee-Flo Corp., Houston, Texas 77011

Balcrank Corp., Cincinnati, Ohio 45209

## GLOSSARY

Defined herein are expressions, terms and nomenclature commonly encountered in the realm of Paints, Sealers and Adhesives

**Acrylic Resin** — A synthetic resin made from derivatives of acrylic acid.

**Adhesive** — A substance compound for bonding materials together by surface attachment. It is not used primarily to fill voids or pores or for sealing purposes. Adhesive is a general term and includes, among others, cement, glue, mucilage, and paste.

**Air Dry** — Drying of a paint or varnish film at ordinary room temperatures (70° to 90° F.) unless a specific temperature is mentioned. See Dry.

**Alkyd Resin** — A synthetic condensation product made from polyhydric alcohols and polybasic acids; generally modified with resins, fatty acids, or fatty oils (such as soybean, linseed, and dehydrated castor). The varnishes are widely used in industrial finishes.

**Anatase** — A crystal structure form of titanium dioxide having a specific gravity of 3.9 and refractive index of 2.53 and characterized by excellent whiteness, high opacity, and low chemical reactivity. See Rutile.

**Aniline Point** — The temperature at which a hydrocarbon solvent becomes miscible with an equal volume of anhydrous and chemically pure aniline. This is frequently referred to as the "critical solution temperature." See Mixed Aniline Point.

**Baking Finish** — An enamel or lacquer which requires application of artificial heat for stated periods of time and at stated temperatures. Baking temperatures at above 150° F. for desired properties.

**Bleeding** — When the color of a previous paint coat is absorbed into the top coat imparting a certain amount of color, it is said to bleed. The solubility of the color ingredient of the undercoat in the vehicle of the new coat is usually the cause of this condition.

**Boot-Topping Paint** — A water, weather and

fouling resistant paint used on the boot-topping area of vessels. The boot-topping area is that area on the exterior of the vessel extending from the light-load waterline to six inches above the full-load waterline.

**Calking Compound** — A dough-like substance designed to fill joints or seams and to remain sufficiently pliable after application to allow for expansion and/or contraction of joints.

**Catalyst** — A substance whose presence changes the rate of a chemical reaction without itself undergoing permanent change in its composition.

**Cement** — A material or a mixture of materials (without aggregate) which, when in a plastic state, possesses adhesive and cohesive properties, and which will harden in place. See Adhesive.

**Chalking** — A phenomenon of paint coatings manifested by the presence of a loose powder, coming from the film itself, or at just beneath the surface. This is best detected on white paint by rubbing a piece of black velvet over it.

**Coating Compound, Bituminous, Emulsion Type** — A composition consisting of an emulsion of bitumens in water.

**Coating Compound, Bituminous, Solvent Type** — A composition containing bituminous ingredients such as asphalt, coal tar, pitch, pine tar, or petroleum residuum with solvents. It may contain inorganic fillers and/or wax.

**Coating Compound, Fluorescent** — A compound for application on objects so that the markings may be visible in the dark during exposure to ultraviolet rays.

**Coating Compound, Internal Boiler Surfaces** — A liquid composition formulated for application on the interior steel and iron surfaces of boilers and boiler tubes to form a rust-proof surface to which water scale does not bond as tightly as to bare steel. Resistant to

## GLOSSARY

hot water and steam. Not affected by high boiler pressure or by wet heat. Does not appreciably retard heat transfer.

**Color** — A term used to denote visual appearance, i.e., red, yellow, etc. Where materials are concerned such as pigments, the term is colorant.

**Consistency** — Relative stiffness or resistance to deformation of a coating composition in bulk; the property may be a composite of plasticity, viscosity, yield value, and thixotropy (a reversible isothermal change from gel to liquid when subjected to stirring or shaking). In the special case of a simple liquid, as distinguished from a complex liquid, the consistency and viscosity are identical. See Viscosity and K.U. (Krebs Units).

**Corrosion Preventive Compound** — A coating compound formulated to physically exclude corrosion causing substances from metal surfaces, and which can be removed by wiping with suitable solvent. It may contain corrosion inhibitors.

**Cut** — As applied to shellac varnishes, the term indicates the number of pounds of dry solid shellac dissolved in alcohol solvent to make up 1 gal. of varnish.

**Diluent** — A liquid, usually a petroleum hydrocarbon, which is blended with an active solvent and used in a varnish or lacquer. It is generally used to increase the bulk and decrease the cost. A diluent may not necessarily be a solvent for the solid ingredients in the vehicle, but nevertheless, its addition can be tolerated within certain limits. See Solvent.

**Dope** — A type of lacquer formulated for coating textile fabric surfaces to increase durability by imparting tautness, weather resistance, and strength.

**Dry** — A term used to indicate when a film of paint, varnish, lacquer, or enamel has become completely solidified. The film is DRY HARD when the maximum pressure that can be exerted between the thumb and finger (without twisting) does not move the film or leave a mark which remains noticeable. The film is DRY FIRM when the soft, tacky condition no longer exists and it feels firm

under moderate pressure of the finger. See Air Dry.

**Drying Oil** — An oil which possesses to a marked degree the property of readily taking up oxygen from the air and changing to a relatively hard, tough, elastic substance when exposed in a thin film to the air. The drying process also involves polymerization. See Polymer.

**Elastomer** — An elastic, rubber-like substance, as natural rubber or any variety of synthetic rubber.

**Enamel** — Consists of pigment dispersed in a varnish containing natural or synthetic resin. The varnish may be modified with drying oil to the extent that the total drying oil content of the vehicle does not exceed 75% by weight of the total nonvolatile portion of the vehicle. When applied in a thin layer, it dries principally by polymerization and/or oxidation to form a hard, smooth, opaque film.

**Enamel, Heat Resisting** — An enamel that has the quality to withstand temperatures of 400° F. and higher.

**Epoxy Resin** — A synthetic resin, generally a copolymer of epichlorhydrin and bisphenol A. Cures to a hard coating by reacting with an amine or polyamide.

**Ester Gum** — A resin made from rosin acids and a polyhydric alcohol such as glycerine.

**Filler, Dent, Metal Surface** — A dough-like pigmented composition formulated for filling dents, creases and imperfections in a metal surface, in order to form a continuous smooth surface with adjacent areas.

**Filler, Wood, Paste** — A composition in paste form containing pigment in the form of finely ground silica or quartz used to fill the pores and grain of wood before applying paint.

**Filler, Wood, Plastic** — A composition consisting of finely divided wood or vegetable fiber, cellulose derivative or resin binding material and volatile solvents. It hardens on evaporation of the solvent and is used primarily for building up or filling in wood patterns, or joiner work. It may be stained to various colors.

**Flammable** — A volatile liquid or a gas which has a flash point of 80° F. or lower with the Tag open-cup tester (ICC definition). Some industries set the limit at 100° F. "Flammable" is preferred to "inflammable" with which it is synonymous.

**Flash Point** — The temperature to which a liquid must be heated before its vapor will "flash" or burn momentarily, when a small flame is applied. Can be measured by means of open cup or closed cup. Method of test should be specified along with temperature.

**Ford Viscosity Cup** — An efflux-type viscometer with an automatic time-recording device attached to measure the time in seconds required for the outflow of the contents.

**Gardner-Holdt Viscosity** — The viscosity of any transparent liquid as measured by the Gardner-Bubble Viscometer. It is based on a standard series of water-white oils sealed in standardized tubes, each given a letter designation. By quickly inverting the tubes in the vertical position, the rates at which the air bubbles rise can be compared with a test sample.

**Gel** — A semisolid system consisting of a network of solid aggregates in which liquid is held.

**Glazing Compound, Sash** — A dough-like compound consisting of pigments mixed in suitable oils and/or resinous vehicles designed for securing glass in a sash. Retains its plasticity for an extended period.

**Gloss, Specular** — The luster, shininess, or reflecting ability of a surface, or the ability of a surface to reflect light regularly. It is based upon the degree of optical smoothness of a surface, variations in smoothness being microscopic. Values above 70 are classified as being full gloss, 70 to 30 as semigloss, 30 to 6 as eggshell, 6 to 2 as flat to eggshell, and 2 or less as flat. 6 or less is also classified as lusterless.

**Glue** — Originally, a hard gelatin obtained from hides, tendons, cartilage, bones, and other connective tissues of animals. Also an adhesive prepared from these substances by hydrolysis (application of water and heat), chemically known as collagen. See Adhesive.

**Gold Size** — A pigmented adhesive composition formulated for attaching gold leaf to surfaces.

**Hiding Power** — The power of a paint or pigment to obscure or render invisible a surface over which it is applied. It is one of the most important physical properties of a white pigment. It is determined by the difference in index of refraction between the material and its surrounding medium. See Refractive Index.

**Iodine Number** — It is the measure of the unsaturation of the fatty acid radicals of vegetable oils and is related to their drying properties. Specifically, it is the number of centigrams of halogen, calculated as iodine, which under specified conditions reacts with one gram of oil.

**Kauri Reduction Test** — A test used to predict the durability of a varnish as a measure of its toughness. The method consists essentially in measuring the amount of added "run-kauri in turpentine solution" necessary to produce a brittle varnish. Higher percentage values indicate greater toughness and durability.

**K.U. (Krebs Units)** — The consistency of most paints is given as so many K.U. as determined by the modified Krebs-Stormer rotary-type viscometer. Since a pigmented liquid coating is not a simple liquid, its consistency as expressed by K.U. is only an apparent measure of its viscosity. See Consistency and Viscosity.

**Lacquer** — A clear or pigmented liquid coating composition which, when applied in a thin layer, sets and dries rapidly to form a solid film chiefly by evaporation of the solvent portion of the vehicle. It is composed basically of a cellulose derivative and/or a blend of resins, such as vinyl, acrylic, polystyrene, and the like, mixed in a solvent, with or without plasticizers.

**Leafing** — The ability of an aluminum or gold bronze paint, to exhibit a brilliant or silvery appearance. This occurs when the flat pigment particles align themselves parallel with the coated surfaces to give the appearance of a solid sheet of metal.

## GLOSSARY

**Linseed Oil, Alkali-Refined** — Unbodied linseed oil which has been alkali treated.

**Linseed Oil, Boiled** — Linseed oil with added drying metallic salts, which may or may not be heated.

**Linseed Oil Mixture, Thinned** — A blend of heat polymerized linseed oil, raw or boiled linseed oil, and volatile thinner, with or without driers.

**Linseed Oil, Raw** — Oil extracted from flaxseed. Does not contain driers.

**Linseed Oil, Thinned** — Consists of raw linseed oil, drier and thinner.

**Mass Color** — The color, when viewed by reflected light, of a pigment-vehicle mixture of such thickness as to obscure completely the background. The dispersed pigment is free from extender or other pigments.

**Metal Conditioning Compound** — A compound specifically formulated for application on metal surfaces to facilitate subsequent removal of rust, and to render the surface resistant to the formation of rust.

**Mineral Spirits** — A volatile petroleum product, intermediate between gasoline and kerosene, used extensively as a thinner for paints and varnishes. Lower in cost than turpentine.

**Mixed Aniline Point** — An accurate and precise control test for thinner solvent power which requires no temperature control. It is the critical solution temperature of a mixture of 10 ml of anhydrous aniline, 5 ml of thinner under test, and 5 ml of normal heptane whose straight aniline point is 140° F. See Aniline Point.

**Nonvolatile Vehicle** — The liquid portion of a paint, enamel, varnish, or related products, excepting the volatile thinners and water.

**Oil Length** — The number of gallons of oil cooked with 100 pounds of resin in the manufacture of a varnish.

**Paint, Antifouling** — The last coat of paint applied to the underwater body of a ship or surfaces of other items which are exposed to sea water. Contains toxic ingredients, such as red or yellow mercuric oxide or red cuprous

oxide. These toxic substances retard the attachment of barnacles and other marine growth.

**Paint, Heat Resisting** — A paint that has the quality to withstand temperatures of 400° F. and higher.

**Paint, Oil** — A paint that uses drying oil, or drying oil modified with varnish, as the principal nonvolatile component of the vehicle. The total drying oil content must be greater than 75% by weight of the total nonvolatile portion of the vehicle.

**Paint, Rubber** — A paint whose basic vehicle is synthetic and/or natural rubber either in solution or emulsion form.

**Paint, Silk Screen Process** — A pigmented paint for use in the manufacture of decalcomanias.

**Paint, Stencil** — A lusterless paint designed primarily for stenciling.

**Paint, Traffic** — A paint used for marking streets, highways, airport runways, and the like. Characterized by rapid drying. Reflectorized by the use of small glass beads.

**Paint, Water, Paste** — A paint whose basic vehicle is an emulsion of drying oils, drying oils and resins, or oil-extended resins, in water.

**pH Value** — A number denoting the degree of acidity or alkalinity of a solution by indicating the hydrogen ion concentration. Values range from 0 to 14 with the neutral point at 7. Below 7 denotes acidity, above 7 denotes alkalinity.

**Phenolic resin** — A synthetic resin made by reacting phenols with aldehydes by an aldol-condensation process.

**Pigment** — A finely divided, substantially insoluble solid used to extend other pigments, impart opacity, color, and/or impart color to a vehicle. It may come in dry powder form, flake form, or paste form. Paste items are pigments ground in drying oil or varnish, with or without small amounts of volatile thinner, wetting and dispersing agents. Asphaltic materials are not pigments unless substantially insoluble in the vehicle.

**Plastic Strip, Adhesive Coated** — A strip of solid material fabricated from organic resin. It is coated with adhesive on one side and has a removable paper or cloth backing. The adhesive is designed to be activated by a solvent.

**Plasticizer** — A liquid or solid organic chemical added to paint, varnish, or lacquer to impart flexibility.

**Plastisol** — A composition of vinyl base resin dispersed in a plasticizer, with or without colorants, stabilizers, and other agents, primarily used as a protective coating on various surfaces against the effects of exposure to various elements, such as weather, fuels, lubricants, acids, and other generally deleterious elements. The compound must be fused at approximately 350° F. or more to achieve a tough, flexible, and nonporous coating after application. A primer may be used to form a base for adhesion of the compound.

**Polymer** — A chemical compound in which some relatively simple unit structure or group is repeated throughout the body of the molecule; a compound in which a number of identical atoms or groups are united by covalent bonds.

**Preservative Coatings, Canvas** — A liquid composition of nonspecific ingredients, for application on fabricated canvas articles, such as life preservers and canopies, to increase the durability of the products. It is of brushing consistency, and penetrates the cloth as well as forms a coating which dries to a hard film. It may impart such properties as resistance to fire, water, mildew and weathering.

**Preservative Coating, Rubber** — An elastomer base preparation which is applied to fabricated rubber products as a preserving agent against cracking, checking, hardening or other forms of deterioration occurring during storage, use, or exposure to weather. It dries to form a coating and comes in either concentrated or ready mixed form.

**Primer Coating** — A coating primarily formulated to form a bond between the surface and the succeeding coat of paint, enamel, and/or lacquer, as the case may be. Metal primers contain rust inhibitive pigments.

Excludes items primarily formulated as surface sealers or adhesives.

**Putty** — A dough-like compound of whiting and linseed oil. It may contain small amounts of white lead, red lead, lampblack, and/or litharge. See Calking Compound.

**Refractive Index** — The ratio of the velocity of light in a certain medium compared with its velocity in air. When light passes from one medium into another, it generally changes velocity. The ratio of the velocity in the first medium to that in the second is the "relative index of refraction" for the two media.

**Resin** — Any of a class of solid or semisolid organic products of natural or synthetic origin generally of high molecular weight with no definite melting point. Resins are generally water-insoluble and have little or no tendency to crystallize. However, certain resins, such as some polyvinyl alcohols and polyacrylates, are readily dispersible in water, and others, such as polyamides and polyvinylidene chloride are readily crystallized.

**Rosin** — A natural resin obtained as a residue in the distillation of crude turpentine from the sap of the pine tree (gum rosin) or from an extract of the stumps and other parts of the tree (wood rosin). Used in some antifouling paints to form soluble matrix.

**Rust Arresting Coating** — A liquid composition consisting basically of a mixture of vegetable oil and animal oil or petroleum derivatives formulated for application on rusted areas to arrest further corrosion. One type dries hard and may be painted over where appearance is not a factor. Another type is for temporary use on a surface only until proper preparation and painting of the surface can be accomplished.

**Rutile** — A form of titanium dioxide having specific gravity of 4.2 and refractive index of 2.71. It is characterized by higher opacity and greater inertness as compared with the anatase crystal structure form. Also characterized by resistance to chalking. See Anatase.

**Sealer, Surface** — A composition in liquid form primarily used to seal porous surfaces, the nonvolatile portion of which contains varnish, drying oils, and/or resins.

## GLOSSARY

**Sealing Compound** — A compound formulated for coating, or for filling voids, cracks, joints, and seams of objects and/or materials to exclude foreign matter and/or to prevent the transmission of fluids therethrough. It is not designed to act as a primer coating or to be sanded or ground after application. It cannot be wiped off. See Calking Compound.

**Shade** — A term descriptive of a lightness difference between surface colors, the other attributes of color being essentially constant. A lighter shade of a color is one that has higher lightness, and a darker shade is one that has a lower lightness. Shade of a color may also be defined as the mixture of black with that color, as opposed to tint. See Tint.

**Shellac, Cut** — Dry shellac dissolved in alcohol. May contain pigment or dyes.

**Shellac, Dry** — A refined natural resin obtained from the crude lac secretion produced by a scale insect (*Laccifer lacca*). May be in various forms such as flakes, disks, pieces or powder. Available in natural color, orange, and also in bleached form.

**Shellac Stick** — A shellac, or other resinous material, in stick form, usually used in the minor repair of wood surfaces. It is applied by melting.

**Silicone** — A polymeric organosiloxane composed of multiples of the structure:

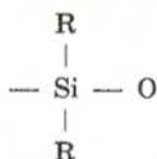

where R is a hydrocarbon radical, or derived therefrom by substitution of oxygen for a portion of the organic groups; a polymeric organosilicon oxide. When used in paints, imparts resistance to heat. See Polymer.

**Solvent** — Any liquid which will dissolve another substance. Solvent power of a liquid is specific, that is, it can dissolve certain substances but not others. See Diluent.

**Specific Gravity** — The ratio of the weight in air of a given volume of material at a stated temperature (usually at 60° F.) to the weight in air of an equal volume of dis-

tilled water at a stated temperature (usually at 60° F.).

**SSU — Standard Saybolt Universal** — The viscosity of petroleum-base, rust-preventive, and metal-conditioning compounds is given as so many seconds, when determined by the Saybolt Universal Viscosimeter.

**Stain** — A liquid composition that colors wood or other similar porous material. It is transparent or translucent. It may be a dye dissolved in water, alcohol, toluene, or other volatile liquid; it may be a mixture of colored pigment, drying oil, and thinner; or a mixture of colored pigment, wood preservative, drying oil, and thinner commonly used for staining shingles.

**Surfacer, Liquid** — A liquid composition mainly used to establish a smooth surface for subsequent application of a topcoat, the nonvolatile portion of which contains pigments, varnish, drying oils, and/or resins.

**Synthetic** — Derived by chemical methods purposely directed to that end, as distinguished from naturally occurring

**Thermoplastic** — Capable of plastic flow or permanent deformation under load when heated; capable of softening repeatedly upon warming.

**Thermosetting** — Having the property of undergoing a chemical reaction by the action of heat, catalysts, or ultraviolet light leading to a relatively infusible state.

**Thinner, Paint, Mineral Spirits** — A straight or blended run of petroleum naphthas stocked as a thinner for paints, varnishes, and enamels, and with a rated aniline point not less than 100° F.

**Thinner, Synthetic Resin Enamel** — A hydrocarbon base thinner of intermediate solvent power which is suitable for thinning synthetic resin base enamels. Contains at least 45% aromatic hydrocarbons.

**Tint** — A color produced by the mixture of white pigment or paint in predominating amount with a colored pigment or paint, not white. The tint of a color is therefore, much lighter and much less saturated than the color itself. See Shade.



**Toner** — An organic pigment which does not contain inorganic pigment or inorganic carrying base. It is usually a heavy metal salt of a water soluble dye.

**Turpentine** — The volatile oil consisting primarily of a number of terpene hydrocarbons of the general formula  $C_{10}H_{16}$  distilled from the products of the pine tree.

**Urethane** — A synthetic resin made from toluene diisocyanate and a polyol. Can be formulated into vehicles for organic coatings.

**Varnish** — A liquid composition which is converted to a transparent or translucent solid film after application as a thin layer.

**Varnish, Asphalt** — A coating composed of asphalts, drying oils, thinners, and driers.

**Varnish, Oil** — A liquid composition of drying oils and resins which is converted to a transparent or translucent hard film after application as a thin layer. It dries and sets by evaporation, oxidation, and polymerization.

**Vehicle** — The liquid portion of any paint, or lacquer. In this case, anything that is dissolved in the liquid portion is part of the vehicle. It may include oils, resins, driers, plasticizers, solvents, diluents, and nitrocellulose.

**Vinyl Resin** — A synthetic resin made from vinyl compounds. Vinyl coatings are usually copolymers of vinyl chloride and vinyl acetate.

**Viscosity** — A property of fluids which may be described as a resistance to flow. Viscosity is the measure of the combined effects of cohesion and adhesion. See Consistency.

**Volatile** — Capable of relatively rapid evaporation under ordinary conditions, as into an

evacuated space at room temperature; capable of exerting an appreciable vapor pressure under the conditions of observation.

**Wash Primer, Metal Pretreatment, Resin-Acid** — Designed for application on clean metal surfaces in order to form a thin coating which increases the adhesion of a subsequently applied coating system. Not intended as a permanent protective coating by itself.

**Wax, Water Emulsion** — A colloidal emulsion of wax in water. It is designed to be used as a protective coating over asphalt tile floors. It can be used over vinyl, and rubber flooring.

**Whiting** — A naturally occurring calcium carbonate which is finely ground and washed. Its prime use is that of a pigment in putty, paint, enamel, and similar items.

#### COMPARISON OF THE HIDING POWER OF VARIOUS WHITE PIGMENTS

Note: Anatase Titanium Dioxide equals 100 as reference.

<i>Name of Pigment</i>	<i>Relative Weights for Equal Hiding</i>
Rutile Titanium Dioxide	90
Anatase Titanium Dioxide	100
Zinc Sulfide	200
Titanium-Calcium (Rutile)	250
Titanium-Barium (Anatase)	300
Lithopone	420
Antimony Oxide	495
Zinc Oxide	540
White Lead	950



# INDEX

This is a simplified index with a minimum of duplicate and cross references. Two numbers, such as 3-4, indicate complete Sections bearing on any subject. Three numbers, such as 3-4-2, indicate Articles within Sections. Numbers having an appended letter, such as 3-4-2(A), indicate paragraphs within Articles. Needless repetitions have been avoided. Where the specifications for any items such as fences, flag poles and the like appear in numerous places, and are all identical, only one or two references have been included for the sake of convenience.

## A

Abrasive Paper Grading, 1-5-7  
Academy, see Administrative Facilities  
Access Plates, color principles, vessels, 3-13-2(D), 3-14-2(D)  
Acid Resistance, Surfaces Requiring, Shore Establishments, 2-2-11 vessels, 2-3-28  
Acrylic Coating, clear, 4-4-7  
Acrylic Emulsion Paint for Masonry, 4-3-5  
Administrative Facilities, color principles, exterior, 3-8-1 color principles, interior, 3-8-2  
Aerial Identification, vessels, 3-13-1(S), 3-22-3  
Air Stations, color principles, exterior, 3-7-1 color principles, interior, 3-7-2  
Aircastles, 3-13-1(B)  
Aircraft, coating systems for, 2-6 color systems, 3-15 painting and marking details, 3-22-3  
Airless spray, 1-9-1(C)  
Alkyd Vehicles, 1-3-7  
Alligatoring, 1-10-2  
Aluminum Paint, Heat-resisting, 4-3-21 Ready-mixed, 4-3-20  
Aluminum Pigment, 1-3-4(D)  
Aluminum Surfaces, exterior, 2-2-2(C) preparation of, 1-5-2  
Ambulances, 3-12-1(A)  
Anchor Chain, coating systems, 2-3-19, 3-14-1(I) markings, 3-13-1(P)  
Anchors, 3-13-1 galvanized, 3-14-1(I)  
Antennas, Radio and Radar, 2-3-18  
Anticorrosive Shipbottom Primer, 4-2-6  
Antifouling Paint, Cold Plastic, 4-3-15, 4-3-16 Polyisobutylene, 4-3-18 Rubber tie-coat for sonar domes, 4-3-19 Vinyl, 4-3-17  
Antimony oxide, 1-3-1(C)  
Antisweat Coating Binder, 4-3-23

Applicator Nozzles, 2-2-12  
Area Offices, see Administrative Facilities  
Asbestos-Cement Siding, 2-2-12  
Asphalt Varnish, 4-4-3  
Auditoriums, color principles, Administrative Facilities, 3-8-2(R)  
Automobile Polish, 4-7-3  
Automobiles, 3-12-1(A)  
Automotive and Power Cranes, 3-11-4  
Aviation Obstruction Marking, 3-3-1, 3-6-1, 3-7-1(G)  
Aviation Runway Marking, 3-7-1(H)  
Awning Ridgepoles, 3-13-1(K)  
Awning Stanchions, 3-13-1(K)

## B

Balustrades, 3-3-1  
Barber Shops, color principles, Administrative Facilities, 3-8-2(O)  
Bare Wood, preparation of, 1-5-4(A)  
Barges, exterior, 3-14-1(A)  
Barges, color principles, floating, 3-11-3 identification markings, 3-14-1(M)  
Barracks, color principles, Administrative Facilities, 3-8-2(C)  
Air Stations, 3-7-2(C)  
Basement Floor Paint, 4-3-8  
Basements, color principles, Air Stations, 3-7-2(J)  
Bases and Depots, color principles, exterior, 3-9-1 color principles, interior, 3-9-2  
Basic Carbonate White Lead, 1-3-1(C)  
Basic Silicate White Lead, 1-3-1(C)  
Basic Sulphate White Lead, 1-3-1(C)  
Battery Rooms, color principles, Air Stations, 3-7-2(J)  
Beach Carts, 3-12-1(A)  
Beams, 3-3-2  
Bells, bronze, 2-2-12  
Benches, 3-3-2(D)  
Bilges, coating systems, 2-3-11 color principles, vessels, 3-13-2(C) 3-14-2(C)  
Bins, 3-3-2(D)  
Bits, 3-13-1(C), 3-13-1(K)  
Bleachers, coating systems, 2-2-1(B) color principles, 3-3-1  
Blistering, 1-10-4  
Blocks, 3-13-1(K)  
Blue, Iron, 1-3-2(B)  
Boat Booms, 3-13-1(K), 3-13-1(L)  
Boat Davits and Boat Stowage, color principles, vessels, 3-13-1(J)  
Boat Houses, color principles, Rescue Stations, 3-5-2(F) Shore Establishments, 3-3-2(B)  
Boatswain's Chairs, wood, 2-2-12, 2-3-23, 3-13-9(L)  
Boiler, color principles, equipment, 3-3-2(D) color principles, rooms, 3-3-2(B)  
Bollards and Cleats, 3-11-5  
Bolts, Threaded Parts, Exposed to Weather, 2-2-12  
Boot-top Painting, 2-3-3

Boot-Topping Paint, Black, 4-3-14  
Bottom Painting, 2-3-2  
Boxing, Paint, 1-6  
Breakwaters, 3-13-1(B)  
Brick Walls, 2-2-12  
Bridge Wings, 3-13-1(B)  
Bridges and Trestles, 3-3-1  
Brightwork, coating systems, 2-2-10 lacquer for, 4-4-6 vessels, 2-3-27  
Brush Keepers, 1-7-5  
Brush Painting, brush construction, 1-7-1 care of brushes, 1-7-5 new brushes, breaking in, 1-7-3 skin irritations, 1-7-7 striping, 1-7-6 technique, 1-7-4  
Brushes, types of, 1-7-2 flat wall, 1-7-2(A) flat sash, 1-7-2(D) flat varnish, 1-7-2(C) lettering, 1-7-2(F) marking, 1-7-2(F) oval sash, 1-7-2(E) oval varnish, 1-7-2(B)  
Building, color principles, Administration Facilities, 3-8-1 Air Stations, 3-7-1 Base and Depots, 3-9-1 Light Stations, 3-4-1 Radio and Loran Stations, 3-6-1 Rescue Stations, 3-5-1 Shore Establishments, 3-3-1  
Bulkheads, color principles, vessels, 3-14-2(A)  
Bulldozers, 3-7-1(I)  
Bulwarks, 3-13-1(B)  
Buoy Boats, 3-14-1(A)  
Buoy Carriers, 3-12-1(B)  
Buoys, coating systems, 2-4 color renewal, 2-4-4 high loss probability, 2-4-3 metal, exterior, 2-4-1 metal, interior, 2-4-2  
Burning Off, old paint from wood surfaces, 1-5-4(C)

## C

Cabins, color principles, vessels, 3-13-1(B), 3-13-1(D)  
Cable, electric, 2-3-17  
Cafeterias, color principles, Air Stations, 3-7-2(G)  
Calcium carbonate, 1-3-3(B)  
Carbonate White Lead 1-3-1(C)  
Calking, buildings, 1-5-4(F) boats, wooden, 1-5-4(E)  
Calking Compound, metal seams, 4-6-3 plastic, 4-6-4 wooden vessels, 4-6-2  
Campaign Ribbons, Painted Replicas, vessels, 3-11-1  
Canvas Covers, 2-2-12  
Cargo Spaces, color principles, vessels, 3-14-1(D)  
Carpeting, 3-10-2

## INDEX

Carryalls, 3-12-1(A)  
Castor Oil, 1-3-5(E)  
Catwalks, color principles,  
2-2-2(I), 3-3-1  
Cedar Closet Linings, 2-2-12  
Ceilings, color principles,  
Administration Facilities, 3-8-2(A)  
Air Stations, 3-7-2(A)  
Bases and Depots, 3-9-2(A)  
Light Stations, 3-4-2(A)  
Radio and Loran Stations, 3-6-2(A)  
Rescue Stations, 3-5-2(A)  
Shore Establishments, 3-3-2  
Cement, hydraulic, 4-6-8  
smoothing, 4-6-7  
Cements, application instructions, 4-6  
ordering information, 4-6  
Chain, galvanized, 2-2-12  
Chain Locker, 2-3-10  
Chalking, 1-10-1  
Chapels, color principles,  
Administrative Facilities, 3-8-2(S)  
Chlorinated Rubber Vehicles, 1-3-10  
Chocks, 3-13-1(C), 3-13-1(K)  
Chrome Green, 1-3-2(E)  
Chrome Yellow, 1-3-2(D)  
Chromium Oxide, and  
Chromium Hydroxide, 1-3-2(F)  
Classrooms, color principles,  
Administrative Facilities, 3-8-2(M)  
Shore Establishments, 3-3-2(A)  
Cleaning Painted Surfaces, 1-5-6  
Closets, 3-3-2(A)  
Clothes Poles, 3-3-1  
Coal Tar Epoxy Coatings, 4-8-3  
Naphtha, 4-5-5  
Coating Systems for, Aircraft, 2-6  
Buoys, 2-4  
Shore Establishments, 2-2  
Vehicles, 2-5  
Vessels, 2-3  
Cockpits, color principles,  
vessels, 3-14-1(D)  
Cofferdams, color systems, 2-3-9  
Color, pigments, 1-3-2  
specifications, 3-24  
standard, misc., 3-23  
use of color, 3-2  
Communication Centers,  
color principles,  
Air Stations, 3-7-2(F)  
Communication Vehicles, 3-12-1(E)  
Companionways, color principles,  
vessels, 3-13-2(K), 3-14-2(I)  
Compartment Colors, vessels, 3-13-2  
Compass Stands, 3-13-1(K)  
Composition Floors, 3-10-1  
Composition of Paint, 1-3  
Compounds,  
application instructions, 4-6  
ordering information, 4-6  
Compressed Gas Cylinder,  
identification, 3-18  
Compressors, 3-11-5  
Concrete, 2-2-12  
Condensation, space subject to  
heavy, 2-3-13  
Contract Painting, 1-11-8  
Control Boxes, 3-11-5

Controllers, electrical, 3-13-1(B)  
Copper and Mercury  
Compounds, 1-3-4(E)  
Copper Naphthenate Wood  
Preservative, 4-2-7  
Corridors, color principles,  
Air Stations, 3-7-2(K)  
Corrosion prevention, red lead,  
1-3-4(A)  
Counter Tops, 3-10-3  
Coverage of Paint, 1-11-3  
Cradles, boat, 3-5-1(H)  
Cranes, dry dock, 3-3-1  
floating dry dock, 3-11-1  
movable, small, 3-3-1  
truck, 3-3-1  
Crash and Rescue Trucks, 3-12-1(C)  
Crawler Cranes, 3-11-1  
Creosoted Wood, 2-2-12

## D

Damage Control and Safety Markings,  
color principles,  
vessels, 3-13-1(M), 3-13-1(G),  
3-14-1(J)  
Davits, 3-13-1(K)  
Deck Chests, 3-13-1(K)  
markings, 3-13-1(L)  
Deck and Floor Enamel, 4-3-7  
Deck Houses, 3-13-1(B)  
Deck treads, non-skid, 3-13-1(L)  
Decks, coating systems, Shore  
Establishments, metal, 2-2-2(J)  
Shore Establishments,  
wood, 2-2-1(B)  
vessels, 2-3-6, 3-13-1(L)  
Decks, color principles, vessels,  
exterior, 3-13-1(C), 3-14-1(C)  
vessels, interior, 3-14-2(B)  
Decoration in Painting, 1-2-2  
Dental Clinics, color principles,  
Air Stations, 3-7-2(L)  
Depots, see Bases and Depots  
Derricks, color principles, 3-3-1  
floating, 3-11-3  
Desks, color principles, 3-3-2(D)  
tops, 3-10-3  
Devran (coating), 4-8-2  
Dew-Point, Temperature of, 1-11-2  
Diaphones, 3-13-1(K)  
Dining Rooms, color principles,  
Air Stations, 3-7-2(G)  
Light Stations, 3-4-2(F)  
Radio and Loran Stations, 3-6-2(F)  
Rescue Stations, 3-5-2(E)  
Direction Finder Stands and  
Loops, 3-13-1(K)  
Dirt Collection, 1-10-8  
Dispensaries, color principles,  
Air Stations, 3-7-2(L)  
District Offices,  
see Administrative Facilities  
Dock Equipment, 3-11-5  
Docks, coating systems, 2-2-1(D)  
color principles, 3-3-1  
Dodgers, canvas, 3-13-1(B)  
Dogs, 3-13-1(L)  
Door Screens, 2-2-7

Doors, coating systems, 2-2-1(L)  
color principles,  
Shore Establishments, 3-3-1  
vessels, 3-13-2(D), 3-14-2(D)  
Downspouts, 2-2-2(F)  
Draft Marks, vessels, marks, 3-13-1(I)  
vessels, numerals, 3-22-2  
Drafting Rooms, color principles,  
Administrative Facilities, 3-8-2(M)  
Shore Establishments, 3-3-2(A)  
Drapery Materials, 3-10-5  
Dredges, floating, 3-11-3  
Dry Dock Cranes, 3-11-1  
Drydocks, 3-11-2  
Dry Wall Construction, Coatings, 2-2-4

## E

Eaves, 3-3-1  
Electric cable, 2-3-17  
shipboard marking, 3-23-8  
Electrical Insulating Varnish, 4-4-2  
Electrical Insulation, 3-23-9  
Electronic Repair Shops,  
see Bases and Depots  
Electronics Stations, see Radio and  
Loran Stations  
Emblems, Ship, 3-13-1(U)  
Emulsion Vehicles, 1-3-12  
Enamel, Equipment, 4-3-9  
Enamel, Exterior Gloss, 4-3-4  
Fire-retardant, 4-3-11  
Interior Gloss, 4-3-10  
Zinc Dust Pigmented, 4-3-23  
Enamel Undercoat,  
Interior White, 4-2-12  
Enamels, application instructions, 4-3  
ordering information, 4-3  
thinner, 4-1  
Engine Rooms, 3-3-2(B)  
Engine Trunks, color principles,  
vessels, 3-13-1(B), 3-13-1(D)  
Engines, 3-11-5  
Ensign Staffs, 3-13-1(K)  
Epoxy Protective Coatings, 4-8-1  
Epoxy Systems, specific, 4-8-2  
Epoxy Vehicles, 1-3-13  
Equipment, airless spray, 4-9-1  
hot spray, 4-9-2  
conventional spray, 4-9-1  
Equipment, color principles, 3-8-1(I),  
Administration Facilities, 3-8-2(U)  
Air Stations, 3-7-1(I), 3-7-1(K),  
3-7-2(P)  
Bases and Depots, 3-9-1(H), 3-9-2(R)  
Light Stations, 3-4-2(M)  
Radio and Loran Stations, 3-6-1(J),  
3-6-2(M)  
Rescue Stations, 3-5-1(H), 3-5-2(K)  
Shore Establishments, 3-3-2(D)  
vessels, 2-3-16  
Exchanges, color principles, 3-7-2(M)  
Expanded Vermiculite, 4-3-25  
Explosion Prevention, spray  
painting, 1-9-7(B)  
Extender Pigments, 1-3-3  
Exterior Surfaces, frequency of  
painting, 1-11-1(B)  
above boot-top, 2-3-4

## F

Federal Standard No. 595,  
for colors, 3-23-1, 3-24

Fences, 3-3-1

Filing Cabinets, color principles,  
3-7-2(P)

Fillers, application instructions, 4-2  
ordering information, 4-2  
shelf life, 4-1

Film Thickness, control of, 1-11-6

Fire Equipment, color principles,  
Bases and Depots, 3-9-1(E)  
vessels, 3-14-2(G)

Fire Extinguishers, Marking, 3-16-2

Fire and Health Hazards in Paint  
Storage and Mixing, 1-4-2

Fire Hose and Nozzles, 2-2-12

Fireman Valves, 3-13-1(K)

Fire Trucks, 3-12-1(C)

First Aid Rooms, color principles,  
Air Bases, 3-7-2(L)

Fish Oil, 1-3-5(D)

Flag Poles, 3-3-1

Flag Staffs, 3-13-1(K)

Flag Towers, 3-3-1

Flaking, 1-10-3

Flashing, 2-2-2(F)

Flash Points of Solvents, 1-9-7(A)

Floatable Equipment, Markings On,  
vessels, 3-13-1(O), 3-14-1(L)

Floating Drydocks, 3-11-2

Floating Equipment, 3-11-3

Floats, 3-3-1

Flood Relief Punts, 3-14-1

Floor Plates, 2-3-6

Floors, coating systems,  
composition, 3-10-1  
concrete, above grade, 2-2-3(E)  
concrete, below grade, 2-2-3(E)  
exterior, 2-2-1(B)  
gymnasium, 2-2-1(I)  
interior, 2-2-1(I)  
linoleum, 3-10-1  
painted, 2-2-1(I)

Floors, color principles,  
Air Stations, 3-7-2(Q)  
Bases and Depots, 3-9-2(S)  
Light Stations, 3-4-2(N)  
Radio and Loran Stations, 3-6-2(N)  
Rescue Stations, 3-5-2(L)  
Shore Establishments,  
exterior, 3-3-1  
Shore Establishments,  
interior, 3-3-2(C)

Floors, not to be painted,  
linoleum, 2-2-12  
industrial shop, 2-2-12  
marble, 2-2-12  
terrazzo, 2-2-12  
treads, non-skid, 2-2-12  
floor sealers, 4-2-9

Fluorescent tubes (lighting), 3-3-3

Fog Signal Stations, see Light Stations

Foundations, color principles,  
Air Stations, 3-7-1(D)  
Light Stations, 3-4-1(E)  
Radio and Loran Stations, 3-6-1(E)  
Rescue Stations, 3-5-1(D)

Foundry, 3-3-2(B)

French Polishing, 2-2-1(K)

Frequency of Painting, 1-11-1

Fuel Oil Tanks, 2-3-8

Functional Uses in Painting, 1-2-3

Furnace Rooms, 3-3-2(B)

Furnishings for Shore  
Establishments, 3-10

Furniture finishing, 2-2-1(J)  
French polishing, 2-2-1(K)  
masking tape, use of, 2-2-1(K)  
metal, painting, 2-2-2(G)  
repairing finishes, 2-2-1(K)  
stick shellac, 2-2-1(K)  
vessels, 2-3-16

Furniture, Fixtures and Equipment,  
color principles,  
vessels, 3-13-2(E), 3-14-2(E)

## G

Galleys, 3-3-2(A)

Galvanized Steel Surfaces,  
exterior, painting of, 2-2-2(B)  
interior, painting of, 2-2-2(E)  
preparation of, 1-5-3

Gangplanks, metal, 3-13-1(K)  
wood, 2-3-23

Gantry Cranes, 3-11-1

Garages, color principles,  
Light Stations, 3-4-2(K)  
Shore Establishments, 3-3-2(B)

Gas Discoloration, 1-10-5

Gaskets, 2-2-12

Gasoline Drums, 3-13-1(K)

Gasoline Storage Racks, 3-13-1(K)

Gasoline Trucks, 3-7-1(I)

Gears, 2-2-12

Generator Rooms, 3-4-2(I)

Glands, packing, 2-2-12

Glare, reduction of, 3-13-1(B)

Gloss Enamel, exterior, 4-3-4

Gratings, wood, 2-2-12

Grease Cups, 2-2-12

Group Offices,  
see Administrative Facilities

Gun Shields, 3-13-1(B)

Gun Tubs, 3-13-1(B)

Guns and Ordnance Equipment,  
color principles  
vessels, 3-13-1(I)

Gutters, color principles, 3-3-1  
painting of, 2-2-2(F)

Gymnasiums, 3-3-2(A)

Gypsy Head Whelps, 3-13-1(L)

## H

Hallways, color principles,  
Light Stations, 3-5-2(H)  
Radio and Loran Stations, 3-6-2(J)  
Rescue Stations, 3-5-2(H)

Hammerhead Cranes, color principles,  
Shore Establishments, 3-3-1  
miscellaneous, 3-11-1

Handrails, vessels, 3-14-1(M)

Hangars, color principles,  
Air Stations, 3-7-2(N)  
Shore Establishments, 3-3-2(B)

Hatch Coamings, 3-13-1(K)

Hatch Covers, color principles,  
vessels, 3-13-2(D), 3-14-2(D)

Hazardous Paint Materials, 1-3-17

Hazards to Air Navigation,  
color principles,  
Air Stations, 3-7-1(G)  
Radio and Loran Stations, 3-6-1(G)

Headquarters, see Administrative  
Facilities

Heads, 3-3-2(A)

Heat Treating Departments,  
color principles,  
equipment, 3-3-2(D)  
Shore Establishments, 3-3-2(B)

Heated Surfaces, color principles,  
vessels, 3-13-2(J), 3-13-2(H)

Heavy Body Mastic Coating, 4-8-4

Heavy Duty Coatings, 4-8

Helmets, safety, 3-21

Highway Signs, 3-20-1

Hose, all types, 2-2-12

Hose Racks, Saddles and Reels,  
3-13-1(K)

Hot Spray Equipment, 4-9-2

Hot Surfaces, boiler fronts,  
heating furnaces, hot water  
heaters, hot water tanks,  
hot piping, smoke pipes, 2-2-2(K)

Hulls, color principles, inside, 3-14-1(D)  
vessels, 3-13-1(A)  
identification markings, 3-13-1(R),  
3-14-1(M)

Hydraulic Cement, 4-6-8

Hydroxide, Chromium, 1-3-2(F)

## I

Identification Markings,  
aerial, 3-13-1(S)  
barges, 3-14-1(M)  
boats assigned to named  
vessels, 3-14-1(M)  
boats assigned to mobile boarding  
teams, 3-14-1(M)  
boats attached to shore stations,  
3-14-1(M)  
boats 30 to 65 feet in length,  
3-14-1(M)  
boats under 30 feet in length,  
3-14-1(M)  
hull, 3-13-1(R), 3-14-1(M)  
reserve small craft, 3-14-1(M)  
signs, 3-20-5  
special purpose, 3-14-1(M)  
vehicles, 3-12-1(E)

Illumination, 3-3-3

Inaccessible Spaces, 2-3-12

Inactive Unit Signs, 3-20-4

Infirmaries, color principles,  
Air Stations, 3-7-2(L)  
Shore Establishments, 3-3-2(A)

Insulators, 2-2-12

Interior Latex Emulsion Paint, 4-3-12

Interior Surfaces, frequency of  
painting, 1-11-1(A)  
vessels, 2-3-5

## INDEX

Interior White Enamel Undercoat, 4-2-12  
Iron Blues, 1-3-2(B)  
Iron, ornamental, 3-3-1  
Iron Oxide, 1-3-2(C)  
Items not to be painted, vessels, 3-13-1(L), 3-14-1(I)

## J

Jack Staffs, 3-13-1(K)  
Jeeps, 3-12-1(A)  
Job Mixed Paints, (Prohibited), 1-3-15

## K

K-guns, 3-13-1(K)  
Knife edges, 3-13-1(L)

## L

Laboratories, color principles, Administrative Facilities, 3-8-2(M) Shore Establishments, 3-3-2(A)  
Lacquer thinner, 4-5-4  
Lacquers, application instructions, 4-4 ordering information, 4-4 shelf life, 4-1  
Ladders, coating systems, metal, 2-2-2(I) not to be painted, 2-2-12 vessels, 2-3-23  
Ladders, color principles, Shore Establishments, 3-3-1 vessels, 3-13-1(B), 3-14-1(M), 3-14-1(I)  
Ladders, boarding, 3-13-1(K)  
Lampblack, 1-3-2(G)  
Lampposts, 3-3-1  
Lantern House, 3-4-1(D)  
LARCs, 3-14-1  
Latex Emulsion Paint, interior, 4-3-12  
Lathes, color principles, Air Station, 3-7-2(P)  
Lattice, wood, 3-3-1  
Launchings, 3-3-1  
Laundries, 3-3-2(A)  
LCMs, 3-14-1  
Laying off (Painting), 1-7-4  
Lead chromates, 1-3-2(A)  
Lead molybdates, 1-3-2(A)  
Leather Coverings, 2-2-12  
Letters and Numerals, 3-22  
Libraries, color principles, Administrative Facilities, 3-8-2(Q)  
Life Rafts, Life Rings, Life Buoys and Life Floats, 3-13-1(K) markings, 3-14-1(L)  
Lifejackets, markings, 3-14-1(L)  
Liferails, 3-13-1(K)  
Light Attendant Stations, see Light Stations  
Light Stations, color principles, exterior, 3-4-1 color principles, interior, 3-4-2  
Light Towers, color principles, 3-4-1(D)  
Light Vessels, 1-13-1(R)

Lighthouses, 3-3-1  
Linoleum Floors, 3-10-1  
Linseed Oil, boiled, 1-3-5(A), 4-5-6 raw, 1-3-5(A) shelf life, 4-1  
Liquid Floor Wax, 4-7-2  
Lithopone, 1-3-1(C)  
Living Spaces, color principles, Light Stations, 3-4-2(D)  
Rescue Stations, 3-5-2(D)  
Shore Establishments, 3-3-2(A)  
Locker Rooms, 3-3-2(A)  
Lockers, 3-13-1(B)  
Locomotives, 3-3-1  
Lookout Towers, 3-3-1  
Lounges, 3-3-2(A)  
Low Light Levels, 3-6-2(H)

## M

Machine Tools, color principles, 3-7-2(P)  
Machinery, coating systems, Shore Establishments, 2-2-2(H) vessels, 2-3-15  
Machinery, color principles, Administrative Areas, 3-8-1(I) Air Stations, 3-7-2(P) Bases and Depots, 3-9-1(H), 3-9-2(R) Light Stations, 3-4-2(M) Rescue Stations, 3-5-1(H), 3-5-2(K) vessels, 3-13-1(I), 3-13-2(F), 3-14-2(F) vessels, decks, 3-13-1(H)  
Machinery, colors, 3-17  
Magnesium Silicate, 1-3-3(A)  
Manufacture of Paint, 1-3-16  
Marine Glue, 2-3-1, 4-6-6  
Marine Inspection Offices, see Administrative Facilities  
Markers, 2-2-12  
Masking Tape, 2-2-1(K)  
Masonry Paint, 4-3-5  
Masonry Surfaces, coating systems, 2-2-3 cleaning, 1-5-5(A) exterior walls, above grade, 2-2-3(A) exterior walls, below grade, 2-2-3(B) interior walls, above grade, 2-2-3(C) interior walls, below grade, 2-2-3(D) not to be painted, 2-2-12 preparation, 1-5-5 pretreatment, 1-5-5(E) repair, 1-5-5(B) sealing, 1-5-6(D) swimming pools, 2-2-3(F) waterproofing, 1-5-6(D)  
Masts and Spars, color principles, vessels, 3-13-1(F)  
Masts, wood, 2-3-22  
Materials, miscellaneous, application instructions, 4-7 ordering information, 4-7  
Mercury Compounds, 1-3-4(E)  
Mess Halls, color principles, Air Stations, 3-7-2(G)

Mess Halls, color principles, Cont'd  
Light Stations, 3-4-2(F)  
Radio and Loran Stations, 3-5-2(E)  
Rescue Stations, 3-5-2(E)  
Shore Establishments, 3-3-2(A)  
Metal Polish, 4-7-6  
Metal Surfaces, coating systems, 2-2-2 aluminum, 1-5-2 galvanized steel, 1-5-3 not to be painted, 2-2-12 roofs, 2-2-5(B) surfaces (except aluminum and galvanized steel), 1-5-1 underground, 2-2-2(J) waterfront, 2-2-2(J)  
Metal Traffic Areas, 2-2-2(I)  
Mildew, 1-10-6  
Milling Machines, color principles, Air Stations, 3-7-2(P)  
Miscellaneous Color Standards, 3-23  
Mobile Boarding Unit Vehicles, 3-12-1(E)  
Mobile Land Equipment, 3-11-4  
Monitors, electric, 3-11-5  
Mooring, see Bases and Depots  
Motor Cargo Boats, 3-14-1(A)  
Motors, 3-5-2(K)  
Mules, 3-7-1(I)

## N

Name Plates, 2-2-12  
Naphtha, coal tar, 4-5-5  
Navigation, Aids to use of color, 3-23-2  
New Brushes, Breaking in, 1-7-3  
Numbered Vessels, 3-13-1(R)

## O

Oars, 3-13-1(L) markings, 3-14-1(L)  
Offices, color principles, Administrative Facilities, 3-8-2(E) Air Stations, 3-7-2(E) Light Stations, 3-5-2(F) Radio and Loran Stations, 3-6-2(F) Rescue Stations, 3-5-2(F) Shore Establishments, 3-3-2(A)  
Oil Cups, 2-2-12  
Oil Holes, 2-2-12  
Oil Vehicles, 1-3-5  
Oleoresinous Vehicles, 1-3-6  
Operations Rooms, color principles, Administrative Facilities, 3-8-2(E) Air Stations, 3-7-2(E) Light Stations, 3-3-4(E) Radio and Loran Stations, 3-6-2(G) Rescue Stations, 3-5-2(F)  
Ordering Paints, 1-11-3  
Ordnance, Working Parts, 2-2-12  
Organo-metallic-tin (TBTO), 1-3-4(F)  
Ovens, 3-3-2(D)  
Overhead Areas, color principles, Shore Establishments, 3-3-2 vessels, 3-13-1(B), 3-13-2(A)  
Oxide, Chromium, 1-3-2(F)  
Zinc, 1-3-1(B)

## P

Paint, aluminum, 1-3-4(D), 4-3-20, 4-3-21  
 coverage, 1-11-3  
 job mixed, prohibited, 1-3-15  
 manufacture, 1-3-16  
 mixing, 1-6  
 ordering, 1-11-3  
 ordering information, 4-3  
 pigment, 1-3  
 records, 1-11-7  
 remover, 1-5-4(D)  
 storage, 1-4, 4-1  
 thinner, 4-5-1  
 vehicle, 1-3

Paint Cleaner, 4-7-5

Paint Drier, 4-1

Paint Failures, alligatoring, 1-10-2  
 blistering, 1-10-4  
 chalking, 1-10-1  
 dirt collection, 1-10-8  
 flaking, cracking and scaling, 1-10-3  
 gas discoloration, 1-10-5  
 mildew, 1-10-6  
 peeling, 1-10-9  
 suction spotting, 1-10-7

Paint Mixers, 1-6

Paint Mixing Attachment, 1-6

Paint Spray Equipment, 4-9

Paint and Varnish Remover, 4-7-4  
 shelf life, 4-1

Painting,  
 application instructions, 4-3  
 contract, 1-11-8  
 dew-point, temperature, 1-11-2  
 downspouts, 2-2-2(F)  
 flashing, 2-2-2(F)  
 frequency, 1-11-1  
 furniture, metal, 2-2-2(G)  
 gutters, 2-2-2(F)  
 laying on, 1-7-4  
 machinery, 2-2-2(H)  
 organizing job, 1-11-4  
 purpose of, 1-2  
 scaffolding, 1-11-5  
 steel, galvanized, exterior, 2-2-2(B)  
 steel, galvanized, interior, 2-2-2(E)  
 steel, ungalvanized,  
 exterior, 2-2-2(A)  
 steel, ungalvanized,  
 interior, 2-2-2(D)  
 supervision of, 1-11  
 surfaces, exterior, 1-11-1(B)  
 surfaces, interior, 1-11-1(A)  
 weather conditions, 1-11-2

Painting Instructions,  
 Miscellaneous details and fittings,  
 3-13-1(K)

Pantries, 3-3-2(A)

Paper, Abrasive, Grading, 1-5-7

Passageways, color principles,  
 Air Stations, 3-7-2(K)  
 Shore Establishments, 3-3-2(A)

Paste Wood Fillers, 4-2-8

Pelorus Pedestals, 3-13-1(K)

Pharmacies, color principles,  
 Air Stations, 3-7-2(L)

Phenolic Resin Vehicles, 1-3-8

Piers, 2-2-1(D)

Pigment, aluminum, 1-3-4(D)  
 emulsion vehicles, 1-3-12  
 extender, 1-3-3, 1-3-12  
 shelf life, 4-1  
 white, 1-3-1

Pilot Houses, color principles,  
 vessels, 3-13-1(B), 3-13-1(D),  
 3-14-1(B)  
 visor, 3-13-1(K)

Piping identification, colors, 3-19-1  
 marking, 3-19-2  
 Shore Establishments, 2-2-2(N)  
 vessels, 2-3-14

Plaques, 2-2-12

Plaster, 2-2-3(C)

Plaster Surfaces,  
 pretreatment, 1-5-5(E)  
 repair of, 1-5-5(C)  
 sealing, 1-5-5(D)

Plastic Boats, 3-14-1(A)

Plastic Wood, 4-6-5

Platforms, 3-3-1

Plumbing Fixtures, 2-2-12

Porcelain Enamel Surfaces, 2-2-12

Port Offices, Captain of the,  
 see Administrative Facilities

Power Rooms, emergency, 3-3-2(B)

Preservatives,  
 application instructions, 4-2  
 ordering instructions, 4-2

Pretreatment—Wash Primer, 4-2-1

Previously Painted Wood  
 Surfaces, 1-5-4(B)  
 cleaning painted surfaces, 1-5-6

Primers, application instructions, 4-2  
 ordering information, 4-2  
 shelf life, 4-1

Primers, Metal Surfaces  
 Magnesium Silicate, 1-3-3(A)  
 Propellers, shafting, 2-3-2(O), 2-3-21

Protection in Painting, 1-2-1

Protective Coatings during  
 Construction, vessels, 2-3-1

Publications and References, 3-23

Pumps, 3-11-5

Putty, white, 4-6-1

## Q

Quonset Huts, 3-3-1

## R

Radar Antenna, 3-13-1(K)

Radio Direction Finder Stands  
 and Loops, 3-13-1(K)

Radio Direction Finder Stations,  
 see Radio and Loran Stations

Radio and Loran Stations,  
 color principles, exterior, 3-6-1  
 color principles, interior, 3-6-2

Radio Rooms, color principles,  
 Air Stations, 3-27-2(F)  
 Light Stations, 3-4-2(E)

Radiobeacon Stations,  
 see Radio and Loran Stations

Racks, 3-3-2(D)

Radiators, 3-3-2(B)

Radio Antenna Poles, 3-3-1

Radio and Radar Antennas, 2-3-18

Radio Towers, 3-3-1

Railings, 3-3-1, wood, 3-13-1(L)

Railway Cranes and Locomotives,  
 color principles, 3-11-4

Ramps, coating principles,  
 Shore Establishments, 2-2-1(D)  
 color principles,  
 Shore Establishments, 3-3-1

Range Light Towers, 3-3-1

Ready Service Lockers, 3-13-1(K)

Receiving Centers,  
 see Administrative Facilities

Reception Rooms, color principles,  
 Administrative Facilities, 3-8-2(D)  
 Shore Establishments, 3-3-2(A)

Records, Paint, 1-11-7

Recreation Rooms, color principles,  
 Air Stations, 3-7-2(H)  
 Light Stations, 3-4-2(F)  
 Rescue Stations, 3-5-2(E)  
 Shore Establishments, 3-3-2(A)

Recruiting Stations,  
 see Administrative Facilities

Red Lead, 1-3-4(A)

Red Lead Primer, Quick Drying, 4-2-2  
 Slow Drying, 4-2-4  
 Vinyl, 4-2-3

References and Publications, 3-23

Refrigeration Boxes, 2-2-8

Release Mechanisms, 3-13-1(L)

Rescue Stations, color principles,  
 exterior, 3-5-1  
 color principles, interior, 3-5-2

Reserve Small Craft, 3-14-16

Respirators, spray painting,  
 air supply, 1-9-6(C)  
 cartridge, 1-9-6(C)  
 dust, 1-9-6(C)  
 filter, 1-9-6(C)  
 hood, 1-9-6(C)

Rest Rooms, color principles  
 Administrative Facilities, 3-8-2(D)  
 Shore Establishments, 3-3-2(A)

Rigging, painted, 3-13-1(K), 3-13-1(L)

Risers, 3-5-2(H)

Road Markings,  
 Coating Systems for, 2-2-9

Road Rollers, 3-11-4

Roller Coating Paint Pans, dip type,  
 1-8-3

Roller Construction, 1-8-1

Rollers, types (paint),  
 double yoke, 1-8-2(D)  
 heavy duty 1-8-2(D)  
 jumbo, 1-8-2(C)  
 trim, 1-8-2(B)  
 specific rollers available, 1-8-4  
 synthetic covers, 1-8-1(L)  
 use and care of, 1-8-4

Roof coating, 4-1

Roof Paint, Tile Red, 4-3-6

Roof Vents, 3-3-1

Roofs, coating systems,  
 metal, 2-2-5(B)  
 shingle, 2-2-5(C)  
 slate, 2-2-5(D)  
 wood, 2-2-5(A)

## INDEX

Roofs, color principles,  
Bases and Depots, 3-9-1(D)  
Light Stations, 3-4-1(E)  
Radio and Loran Stations, 3-6-1(E),  
3-3-1  
Rescue Stations, 3-5-1(D)  
Shore Establishments, general, 3-3-1  
Rubber Solution Vehicles, chlorinated,  
1-3-10  
Running Light Screens,  
color principles,  
vessels, 3-13-1(G), 3-14-1(G)  
Runway Markings,  
coating systems, 2-2-9  
color principles, 3-7-1(H)  
Rust Preventive, Thin Film, 4-2-13

## S

Safety Color Code, 3-16  
Safety Color Markings,  
color principles,  
vessels, 3-13-2(H)  
Safety Helmets, color systems,  
3-2-1  
Safety, need for, 1-2-4  
Safety Precautions in Abrasive  
Cleaning, 1-5-8  
protective clothing, 1-5-8(A)  
safety rules for dryblast, 1-5-8(B)  
safety rules for wetblast, 1-5-8(C)  
Safety Signs, 3-20-2  
Sandblasting, 1-5-1  
Sanitary Spaces, color principles,  
Air Stations, 3-7-2(I)  
Light Stations, 3-4-2(G)  
Radio and Loran Stations, 3-6-2(I)  
Rescue Stations, 3-5-2(G)  
Shore Establishments, 3-3-2(A)  
Saws, power, color principles,  
Air Stations, 3-7-2(P)  
Scaffolding, 1-11-5  
Scientific Practice in Use of Color,  
shore establishments, 3-2-1  
vehicles, 3-2-1  
vessels, 3-2-1  
Scooters, 3-12-1(B)  
Sculleries, 3-3-2(A)  
Sealers, application instructions, 4-2  
ordering information, 4-2  
Searchlight, shutters, 3-13-1(L)  
Searchlights, 3-13-1(K)  
Shapers, color principles  
Air Stations, 3-7-2(P)  
Shelf Life of Paints, Varnishes and  
Related Products, 4-1  
Shelving, 3-3-2(D)  
Shingles, 2-2-1(F)  
roofs, 2-2-5(C)  
Ship Emblems, 1-13-1(U)  
Shipboard Boats, 3-14-1(A)  
Shipboard Storage of Paints, 1-4-4  
Shipways, color principles,  
Shore Establishments, 3-3-1  
miscellaneous, 3-11-1  
Shops, color principles,  
Air Stations, 3-7-2(O)  
Bases and Depots, 3-9-2(N)  
Light Stations, 3-4-2(C)

Shops, color principles, Cont'd  
Radio and Loran Stations, 3-5-2(C)  
Rescue Stations, 3-5-2(C)  
Shore Establishments, 3-3-2(A)  
Skin Irritations (Painting), 1-7-7  
Smokestacks, coating system, 2-3-24  
Smokestacks, color principles,  
Bases and Depots, 3-9-1(E)  
Smoother Cement for Iron  
or Steel, 4-6-7  
Snow Plows, 3-12-1(B)  
Snowmobiles, 3-12-1(B)  
Soffits, 3-5-2(H)  
Solvents and Thinners, 1-3-14  
Sonar Domes, 2-3-26  
Soybean Oil, 1-3-5(C)  
Spar Varnish, 4-4-1  
Spare Parts Storerooms, 3-7-2(J)  
Spark Proof Floors, 2-2-12  
Spars, wood, 2-3-22  
Special Purpose Pigments, 1-3-4  
Specifications, Color, 3-2-4  
Spontaneous Combustion, 1-4-2  
Spray Painting, care of equipment,  
1-9-5  
fire and explosion data, 1-9-8  
operation of equipment, 1-9-4  
Parts of conventional systems, 1-9-2  
bleeders and non-bleeder guns,  
1-9-2(A)  
conventional gun, 1-9-3  
internal and external mix guns,  
1-9-2(B)  
pressure and suction feed  
guns, 1-9-2(C)  
safety precautions, general, 1-9-6  
airless equipment, 1-9-6(B)  
fire and explosion, 1-9-6(A)  
health precautions, 1-9-6(C)  
skin and eye care, 1-9-6(D)  
safety precautions, interior  
painting, 1-9-7  
flash points of solvents, 1-9-7(A)  
lower explosive limits of solvents,  
1-9-7(A)  
mandatory requirements, 1-9-7(C)  
Spray Painting Equipment, 1-9-1  
conventional 1-9-1(A)  
Spray Shield, 3-13-1(K)  
Spraying Lacquer, 4-4-4  
Stacks, color principles,  
vessels, 3-13-1(E)  
Stages, 2-2-12  
Stain, 4-1  
Stairs, color principles, exterior,  
3-3-1  
interior, 3-3-2(A)  
Air Stations, 3-7-2(K)  
Light Stations, 3-4-2(H)  
Radio and Loran Stations, 3-6-2(J)  
Rescue Stations, 3-5-2(H)  
Shore Establishments, 3-3-2(A)  
Stanchions, color principles,  
Air Stations, 3-7-2(P),  
vessels, 3-13-1(B), 3-14-1(I)  
Standard Lettering System, 3-22-1  
Station Wagons, 3-12-1(A)  
Steps, 2-2-1(B)  
Stick Shellac, Use of, 2-2-1(K)

Stock Rooms, 3-3-2(B)  
Storage of Flammable Liquids,  
color principles,  
Bases and Depots, 3-9-1(F)  
Storage and Utility Spaces,  
color principles,  
Air Stations, 3-7-2(J)  
Bases and Depots, 3-9-2(I)  
Light Stations, 3-4-2(I)  
Radio and Loran Stations, 3-6-2(K)  
Rescue Stations, 3-5-2(I)  
Shore Establishments, 3-3-2  
Storm Warning Towers, 3-3-1  
Stringers, 3-5-2(H)  
Striping, 1-7-6  
Striping Paint, 4-3-13  
Strongbacks, wood, 3-13-1(L)  
Structures, miscellaneous,  
color principles,  
Shore Establishments, 3-3-1  
Suction Spotting, 1-10-7  
Superstructure, color principles,  
vessels, 3-13-1(B), 3-14-1(B)  
Supervision of Painting, 1-11  
Supply Centers, see Bases and Depots  
Supply Depots, see Bases and Depots  
Surface Preparation, 1-5  
aluminum, 1-5-2  
galvanized steel, 1-5-3  
masonry, 1-5-5  
metallic, 1-5-1  
vessels, 2-3-28  
wood, bare, 1-5-4(A)  
previously painted, 1-5-4(B)  
Surfaces Not To Be Painted,  
Shore Establishments, 2-2-12  
vessels, 2-3-29  
Surface Sealer, 4-1  
Swimming Pools, 2-2-3(F)  
Switch Boxes, 3-13-1(B)  
Synthetic Enamel Thinner, 4-5-2

## T

Tables, 3-3-2(D)  
Tank Trucks, 3-12-1(E)  
Tanks, compressed air, 3-18,  
flammable liquid, 2-2-2(O)  
fuel oil, 3-4-5  
steel, 2-2-2(M)  
water, 2-2-2(L)  
water, vessels, 2-3-7  
wood, 2-2-6  
Tanks, color principles,  
Light Stations, 3-4-1(G)  
Radio and Loran Stations, 3-6-1(G)  
Rescue Stations, 3-5-1(G)  
Shore Establishments, 2-2-2(O),  
3-3-1, 3-11-5  
Test Stands, color principles,  
Administrative Facilities, 3-7-2(P)  
Testing Apparatus, color principles,  
Administrative Facilities, 3-7-2(P)  
Theaters, color principles,  
Administrative Facilities, 3-8-2(R)  
Thinners, application instructions, 4-5  
ordering information, 4-5  
Thinners, Solvents and, 1-3-14



Tile and Ceramic Tile, 2-2-12  
 TICWAN Boats, 3-14-1  
 Tillers, 3-13-1(K)  
 Titanium-calcium, 1-3-1(C)  
 Titanium Dioxide, 1-3-1(A)  
 Toboggans, 3-12-1(B)  
 Toluidine Red Toners, 1-3-2(A)  
 Tool Grinders, color principles,  
   Air Stations, 3-7-2(P)  
 Towers, color principles, flags, 3-3-1  
   Light Stations, 3-4-2(L)  
   lookout, 3-3-1  
   radio, 3-3-1  
   range light, 3-3-1  
   storm warning, 3-3-1  
 Towing Rail, 3-13-1(L)  
 Tractors, 3-7-1(I)  
 Traffic Areas, color principles,  
   Air Stations, 3-7-1(J)  
   Bases and Depots, 3-9-1(G)  
   Light Stations, 3-4-1(H)  
   Radio and Loran Stations, 3-6-1(I)  
   Rescue Stations, 3-5-1(G)  
 Traffic Paint, 4-3-22  
 Trailers, 3-12-1(A)  
 Training Rooms, 3-3-2(A)  
 Training Stations,  
   see Administrative Facilities  
 Transducers, 2-3-26  
 Transporters, 3-7-1(I)  
 Trash Scoops, 3-11-5  
 Trim, color principles,  
   Administrative Facilities, 3-8-2(B)  
   Air Stations, 3-7-2(B)  
   Bases and Depots, 3-9-2(B)  
   Industrial, 3-3-2(B)  
   non-industrial, 3-3-2(A)  
   Light Stations, 3-4-2(B)  
   Radio and Loran Stations, 3-6-2(B)  
   Rescue Stations, 3-5-2(B)  
   Shore Establishments, 3-3-1  
 Trucks, color principles,  
   fire, crash and rescue, 3-12-1(C)  
   lift and pallet, 3-7-1(I)  
   other, 3-12-1(B)  
 Truck-tractors, 3-12-1(A)  
 Tung (China wood) Oil, 1-3-5(B)

## U

Underground Metal Surfaces, 2-2-2(J)  
 Ungalvanized Steel,  
   exterior painting of, 2-2-2(A)  
   interior, painting of, 2-2-2(D)  
 Upholstering Materials, 3-10-4  
 Utility Boats, 3-14-1(D)

## V

Valves, 2-2-12  
 Varnishes, application instructions, 4-4  
   ordering information, 4-4  
   shelf life, 4-1  
 Vegetable Lockers, 3-13-1(K)  
 Vehicles, at Air Stations, 3-7-1(I)  
   exterior colors, 3-12-1  
   interior colors, 3-12-2  
   safety markings, 3-12-1(F)  
   use of color, 3-2-1

Vehicles, coating systems, new  
 vehicles, 2-5-1  
   repainting, 2-5-2  
   undercoating, 2-5-3  
 Vehicles, color systems, 3-12  
 Vehicles, paint, alkyd, 1-3-7  
   chlorinated rubber, 1-3-10  
   emulsion, 1-3-12  
   epoxy, 1-3-13  
   oil, 1-3-5  
   oleoresinous, 1-3-6  
   phenolic resin, 1-3-8  
   silicone, 1-3-11  
   vinyl resins, 1-3-9  
 Vent and Exhaust Ducts, 3-3-2(D)  
 Ventilation ducts, 3-13-1(B)  
 Ventilators, 3-13-1(K)  
 Vessel Identification,  
   abbreviations, 3-14-1(M)  
 Vessels, coating systems,  
   anchor chain, 2-3-19  
   bilges, 2-3-11  
   boatswain's chairs, 2-3-23  
   boot-top painting, 2-3-3  
   bottom painting, 2-3-2  
   brightwork, 2-3-27  
   chain locker, 2-3-10  
   cofferdams, 2-3-9  
   electric cable, 2-3-17  
   equipment, 2-3-16  
   exterior, above boot-top, 2-3-4  
   floor plates, 2-3-6  
   fuel oil tanks, 2-3-8  
   furniture, 2-3-16  
   gangplanks, 2-3-23  
   inaccessible spaces, 2-3-12  
   interior, 2-3-5  
   ladders, 2-3-23  
   machinery, 2-3-15  
   masts and spars, 2-3-22  
   piping, 2-3-14  
   propeller shafting, 2-3-21  
   propellers, 2-3-20  
   protective coatings during  
     construction, 2-3-1  
   radio and radar antennas, 2-3-18  
   smoke stacks, 2-3-24  
   sonar domes, 2-3-26  
   space subject to heavy  
     condensation, 2-3-13  
   staging, 2-3-23  
   surfaces not to be  
     painted, 2-3-29  
   surfaces requiring acid  
     resistance, 2-3-28  
   transducers, 2-3-26  
   voids, 2-3-9  
   water tanks, 2-3-7  
   zinc anodes, 2-3-25  
 Vessels, color principles, 65 feet in  
   length or over, exterior, 3-13-1  
   interior, 3-13-2  
   surfaces not to be painted, 3-13-1(L)  
 Vessels, color principles, less than  
   65 feet in length, exterior, 3-14-1  
   interior, 3-14-2  
 Vessels, surfaces not to be painted,  
   2-3-29

Vinyl Alkyd Paint, Exterior, 4-3-3  
 Vinyl Boot-topping Paint, 4-3-14  
   thinner, 4-5-3  
 Vinyl Resin Vehicles, 1-3-9  
 Voids, coating systems, 2-3-9  
   color principles,  
     vessels, 3-13-2(C), 3-14-2(C)

## W

Wainscoting, wood, 2-2-1(G)  
 Wall Primer-Sealer, interior, 4-2-11  
 Walls, 3-3-2(A)  
 Walls, masonry,  
   exterior, above grade, 2-2-3(A)  
   exterior, below grade, 2-2-3(B)  
   interior, above grade, 2-2-3(C)  
   interior, below grade, 2-2-3(D)  
 Walls, wood, 2-2-1(G)  
 War Service Insignia, 3-13-1(Q)  
 Wardrooms, color principles,  
   Administrative Facilities, 3-8-2(D)  
   Air Stations, 3-7-2(D)  
   Shore Establishments, 3-3-2(A)  
 Warehouses, 3-3-1  
 Warning Signs, 3-20-2  
 Waste Receptacles, 3-3-1  
 Water Tanks, coating systems, 2-2-6  
   Shore Establishments, 2-2-2(L)  
   vessels, 2-3-7  
 Waterfront Metal Surfaces, 2-2-2(J)  
 Waterways, 1-13-1(C)  
 Weather Conditions for  
   Painting, 1-11-2  
 Weather Vanes, 3-3-1  
 Welding Generators, 3-11-5  
 Wet-Sandblasting Chemicals, 4-7-1  
 Wharves, 2-2-1(D)  
 Wheelhouse Visors, 3-13-1(B)  
 White Pigments, 1-3-1  
 Winches, color principles, 3-3-1,  
   3-11-5  
 Wind Instrument Staffs, 3-3-1  
 Window Sash, 3-3-1  
 Window Screens, 2-2-7  
   Shades, 3-10-6  
 Windows, wood, 2-2-1(L)  
 Wire Screening, 3-3-2(D)  
 Women's Rest Rooms,  
   Administrative Facilities, 3-8-2(D)  
 Wood Filler, paste, 4-2-5  
   shelf life, 4-1  
 Wood Primer, exterior, 4-2-1(O)  
 Wood Surfaces, bare wood, 1-5-4(A)  
   bleachers, 2-2-1(B)  
   burning-off, 1-5-4(C)  
   calking, boats, 1-5-4(E)  
   calking, buildings, 1-5-4(F)  
   calking compounds, 4-6-2  
   coating systems, 2-2-1(A)  
   creosotes, 2-2-1(E)  
   decks, 2-2-1(B)  
   docks, 2-2-1(D)  
   doors, 2-2-1(L)  
   floors, 2-2-1(B)  
   floors, gymnasium, 2-2-1(I)  
   floors, painted, 2-2-1(I)  
   furniture, finishing, 2-2-1(J)

## INDEX

Wood Surfaces, bare wood, Cont'd  
not to be painted, 2-2-12  
paint remover, 1-5-4(D)  
painted, 2-2-1(I)  
piers, 2-2-1(D)  
preparation, 1-5-4  
previously painted, 1-5-4(B)  
previously stained, 2-2-1(F)  
ramps, 2-2-1(D)  
roofs, 2-2-5(A)  
shingles, 2-2-1(F)  
siding, 2-2-1(F)

Wood Surfaces, bare wood, Cont'd  
signs, exterior, 2-2-1(C)  
steps, 2-2-1(B)  
trim, interior, 2-2-1(H)  
wainscoting, 2-2-1(G)  
walls, 2-2-1(G)  
wharves, 2-2-1(D)  
windows, 2-2-1(K)  
Wood Water Tanks, 2-2-6  
Workshops, 3-3-2(B)  
Work benches, color principles,  
Air Stations, 3-7-2(P)

## Y

Yard, see Bases and Depots  
Yellow, Chrome, 1-3-2(D)

## Z

Zinc, Anodes, 2-3-25, 3-13-1(L)  
Zinc Chromate, 1-3-4(B)  
Zinc Dust, 1-3-4(C)  
Zinc Dust Pigmented Enamel, 4-3-23  
Zinc Oxide, 1-3-1(B)  
Zinc Silicate Coatings, inorganic,  
4-8-5  
Zinc Sulfide, 1-3-1(C)



