

ALL HANDS



MAY 1977



*You pushed WHICH button!!!
(For more on refresher training at Guantanamo Bay, Cuba, see page 4. Photo by PH1 Terry Mitchell.)*

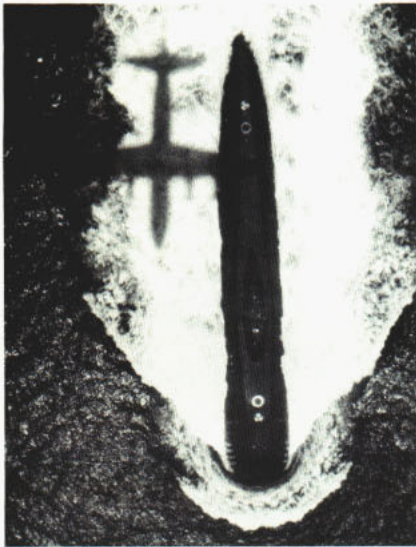

Page 14



Page 26



Page 32

ALL HANDS

MAGAZINE OF THE U.S. NAVY – 54th YEAR OF PUBLICATION
MAY 1977 NUMBER 724

Features

- 4 **NO PLACE FOR THIN SKINS**
A fresh look at Gitmo refresher training
- 14 **SEARCHING FOR NEW RED SEAS**
An interview with RADM Harvey, Dir. of Naval Intelligence
- 22 **LIFE IN THE SOVIET NAVY**
... And we thought WE had it rough
- 26 **RUBE GOLDBERG WOULD BE PROUD**
The Naval Academy develops a heat balanced engine
- 32 **THERE AREN'T ANY STOP SIGNS IN THE AIR**
The demanding job of Navy air controllers
- 40 **BEST IN THE NAVY**
SecNav awards for messes and clubs
- 43 **FROM KATHMANDU TO EVEREST**
Two Navy men trek through Nepal
- 46 **HELPING NAVY FAMILIES IN NEED**
The Navy Relief Society in action

Departments

- 2 Currents
- 13 Grains of Salt
- 30 Rights and Benefits
- 38 Bearings

Covers:

Front Cover: A Tartar missile is fired from the Tartar-D surface-to-air launcher on the forward deck of the nuclear-powered guided missile cruiser USS California (CGN 36). Photo by PH1 William J. Pointer.

Chief of Naval Operations: Admiral James L. Holloway III
Chief of Information: Rear Admiral David M. Cooney
Dir. Print Media Div. (INRA): Lieutenant Commander D. McCurrach
Editor: John F. Coleman
Production Editor: Lieutenant John Alexander
Layout Editor: E. L. Fast
Art Editor: Michael Tuffli

Staff: LT Bill Ray
 JO1 John Yonemura
 JO1 Jerry Atchison
 DM1 Lloyd Marshall
 JO1 (SS) Peter Sundberg
 PH1 Terry Mitchell
 JO2 Dan Wheeler
 JO2 Davida Matthews
 JO3 Alan Meyer
 JO3N Francis Bir
 Edward Jenkins
 Elaine McNeil

Currents

Arlington Interment

Criteria Expanded ● The Department of Defense recently announced revised criteria for interment in Arlington National Cemetery, effective Apr. 15, 1977. The acquisition of additional land by the cemetery has provided room for approximately 100,000 more graves and will extend the life of Arlington as an active cemetery through the year 2000. Under the expanded criteria, veterans who have been awarded the Distinguished Service Cross, the Air Force Cross, the Navy Cross, the Distinguished Service Medal, the Silver Star or the Purple Heart and were honorably discharged, now will be eligible for burial in Arlington. Veterans who were separated from active duty with a physical disability of 30 per cent or greater also will be eligible. Since 1976, eligibility has been limited to persons who died while on active duty, those eligible for retirement compensation, Medal of Honor recipients, high government officials who were veterans and the dependents of those eligible or already buried at Arlington.

Uniform and Grooming

Regulations Revised May 1, 1977 ● A forthcoming "Change Two" to Navy Uniform Regulations contains several changes which will further standardize Navy uniform and grooming regulations. The changes, which go into effect on May 1, include specific grooming standards on beards and moustaches, provide guidance on regulation uniform items obtained from non-Navy sources and set uniform requirements for travel on government aircraft. The regulations specify length and bulk guidelines for beards similar to those already in effect for hair. The bulk of a beard (distance that the mass of facial hair protrudes from the skin on the face) shall not exceed one-half inch. The length of individual facial hair shall be limited to three-quarters of an inch. Additionally, when a moustache is worn with a beard, it must blend smoothly into the beard. A new article in the revised uniform regulations also provides guidelines for personnel interested in suggesting changes to Navy uniforms. Full details on changes and additions to uniform and grooming standards are contained in BuPers Notice 1020 of 2 Mar 1977.

1977 Navy League

Award Winners Announced ● The Navy League of the United States has announced this year's winners of its national awards. The awards recognize outstanding individual achievements in leadership, maritime affairs, science, service to community and literature. The winners are: Rear Admiral Kent J. Carroll, Commander, Naval Forces, Marianas; Air Controlman 1st Class Joe D. Huey, *USS John F. Kennedy*; Senior Chief Air Controlman Bonnie Sue Creamer, Recruit Training Command, Orlando, Fla.; Commander Allison J. Holifield, Officer in Charge, Nuclear Powered Research Submarine NR-1; and E. B. Potter, Professor of Naval History, U.S. Naval Academy.

Junior Officers

Needed for Nuclear-Power Training ● The rapid expansion of the Navy's nuclear-powered force has created a demand for qualified unrestricted line junior officers (O-3 and below). The Navy currently has 29 Los Angeles class submarines, five Trident submarines, three Virginia class cruisers and two Nimitz class aircraft carriers authorized or under construction in addition to the 115 nuclear-powered ships currently in operation. Nuclear-trained officers are needed to fill billets in these ships and those scheduled to be built in the future. Eligible officers are encouraged to apply for nuclear-power training in accordance with BuPers Manual, 6610300. Details are in NavOp 038/77 of March 1977.

Yeoman, Personnelman

Volunteers Sought for Submarine Duty ● An increase in requirements for Yeomen and Personnelmen on submarines has created a pressing need for volunteers from the YN and PN ratings. Currently, there are 24 billets in Pacific Fleet submarines and 67 billets in Atlantic Fleet submarines open for Yeomen and Personnelmen in pay grades E-4 and below. Specific homeport requests will be guaranteed. Requests may be submitted on NavPers 1307/6 in accordance with Chapter Five of the Enlisted Transfer Manual. For further information, interested personnel may contact their detailer or Enlisted Rating Coordinator for Submarines (Autovon 224-1014).

Self-Help Bronze Hammer

Awards Program Winners Announced ● The Chief of Naval Operations has announced the winners of the Navy Self-Help Bronze Hammer Awards Program. The program recognizes those naval activities which have made the most progress in improving the quality of Navy life by using self-help for the enhancement of living quarters and personnel support, welfare and recreational facilities. The winners and runners-up in each category are:

Category	Winner	Runner-up
Construction Battalion in the area, enlisted allowance greater than 1,000	NAS, Alameda	NTC, San Diego
Construction Battalion in the area, enlisted allowance less than 1,000	NS, Pearl Harbor	NSA, Treasure Island
Construction Battalion not in the area, enlisted allowance more than 1,000	NSA, Philadelphia	NAS, Chase Field
Construction Battalion not in the area, enlisted allowance less than 1,000	NSG, Winter Harbor	NWC, China Lake

In addition, special awards were made to the Pinehurst Community Center at NAS Lakehurst, and to Helicopter Anti-Submarine Squadron Light Thirty-five at San Diego.

No place for thin skins

Gitmo Refresher Training

BY JO2 DAN WHEELER
PHOTOS BY
PHI TERRY MITCHELL

A sailor fumbles with his OBA. An instructor throws out a question about damage control. The answer catches in a fireman's throat. A flame-safety lamp malfunctions and a petty officer's eyes close in despair—what else can go wrong? Even the engines seem to cough and stutter in embarrassment while a division officer and CPO commiserate in silence.

They thought their men were ready for Gitmo. They weren't.

That's what refresher training at the Guantanamo Bay Naval Base can do to a crew. It usually does. No one claimed training would be easy and it isn't.

Officers and men in a ship undergoing instruction can expect to work half days—that's 12 hours under the gun, six days a week. Underway at 0600, sometimes earlier; tied up again at 1800, sometimes later—and that's the easy part. Time in-between is spent drilling, practicing, learning.

General Quarters quickly becomes the standard steaming condition. Engineering and damage control drills, warfare exercises and maneuvering operations are the Plan Of The Day, not just one day, but every day. For four weeks there is no stand down.

Gitmo is the toughest, most thorough shipboard training the Atlantic Fleet has to offer. It makes a ship combat-ready and molds her crew into an efficient fighting team. After a few days under the scrutiny of Fleet Training Group (FTG) instructor/observers (I/O), seasoned Navy men sharpen their skills, recruits get a taste of "salt" and a large helping of confidence. Gitmo demands even more. No operational procedure, fleet doctrine or piece of gear escapes untested.

"The training here pays off," said a 30-year senior chief, one of Gitmo's I/Os. "What they learn here may someday save their lives or possibly their ship. Down here a green crew becomes a team in short order."

Ships come to FTG for shakedown cruises manned by men who never served together before. They come from extended stand down periods and from the yards. Most ships have experienced a high rate of crew turnover since their last trip to Guantanamo. Some are sharper than others, but they all need one thing—intensified, uninterrupted training.

Gitmo isn't a place for thin skins. Said one CO after a particularly trying day, "Sure I'm concerned about the discrepancies, but you can't let yourself get upset. Each commanding officer has to realize that if his crew were at the level of training they should be, his ship wouldn't be here.

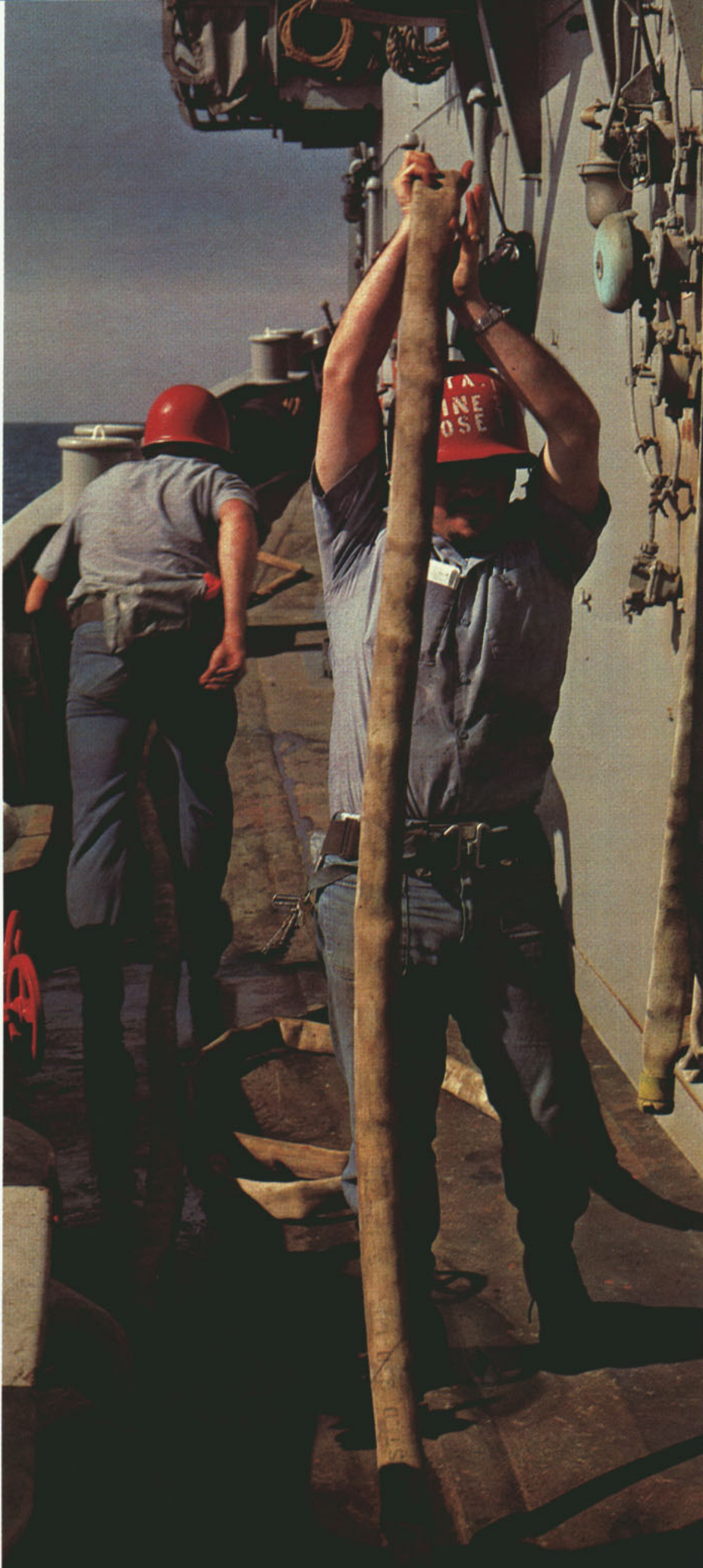

Firefighting teams don't waste time when there is a drill.

Each group of I/Os gives the captain a report on the day's drill results. This captain has been to Gitmo several times and is not upset by his crew's initial failure to score highly.

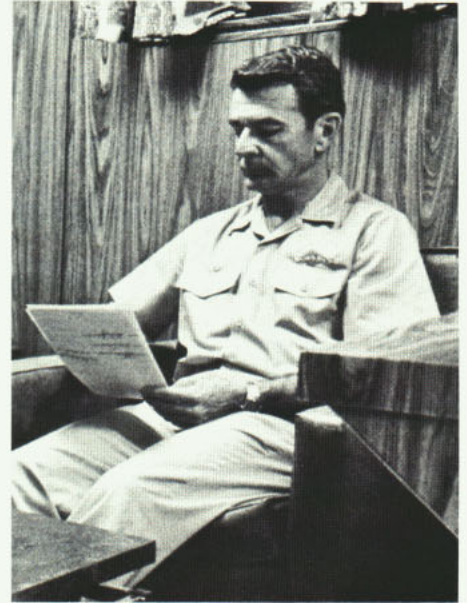

The only thing that concerns me is, 'are my men trainable?'" The answer to that question begins to unfold on a ship's first day in Gitmo.

The FTG I/Os explain to each division what will be expected of them. Informative handouts are distributed to every sailor. Each is given a list of questions and answers about his job which he is expected to learn and learn well.

Quizzing individuals, however, is only a small part of the overall training procedure. The primary objective is two-fold. First, each division and department must be taught to operate as a team. Weak links have to be identified and given extra instruction. Each individual must understand what role he plays in the team operation.

Next, each division has to be taught how to operate as a part of the ship's overall team, a unified crew. No longer is the weapons department, for instance, unconcerned about the engineering department—now each learns

When a personnel casualty strikes, sometimes it's necessary to give some on-the-scene instruction.

Drills are held both in port and at sea. Sailors tote rescue and assistance gear onto the pier during one of numerous inport drills.



how its job depends on the performance of the other. When malfunctioning gear in any department breaks the rhythm, each segment of the team must continue to carry the ball. Not until a crew learns to do that are they ready to leave Gitmo.

The first step is the "walk-through"—ungraded drills for each division. Again an I/O explains what is expected and then solicits questions. "Speak up!" he said, "there's no such thing as a stupid question, just people acting stupid by not asking." Questions are asked, answered, and then the walk-through begins. Content of these initial walk-throughs is the same as those to be faced later except no grade is recorded. Its purpose is entirely instructional.

A typical example was a berthing compartment fire (drill) recently sprung by I/Os on a ship in training. The word was passed on the 1MC and a fire party went into action. They took too long and soon the voice of an I/O penetrated their battle dress station.

"Hey, you got a fire here! Are you going to put it out? Who's the scene leader here, who's in charge?"

A big sailor clad in fire fighting gear said, "Me."

"Scene leader, take charge of your men!"

The time factor is important in drills, yet the safety factor is never ignored. Equipment is never tied up to the point that it cannot be activated quickly in case of a genuine emergency.

Those initial drills don't win any commendations. It's obvious that most of the crew knows generally what they should be doing, but they're nervous and make mistakes. In the case of the fire drill just described, the I/O stopped it and gave each man individual instruction. Then he fired a salvo of questions. If a crew member hesitated for more than an instant, the I/O answered his own question and fired another. When that walk-through was over, the division knew they'd been drilled and had profited from it.

Following each drill there's a brief-

ing for the crew in which strong points are noted and weak points discussed. There's no brow beating or yelling. The tone is subdued but intense like that in a classroom where a professor is teaching students eager to learn. "Today you had a little problem," began the I/O, "but that's O.K. You're here to learn and we're here to teach you. Before long this will be routine and your scores will show it."

Frequently, when a briefing is completed, the leading petty officer (LPO) or chief asks an I/O if it's possible for him to come aboard after hours and critique several of their drills, off the record. It's not an unusual request and most I/Os don't object to returning.

After the crew is briefed, the captain is brought up to date on his ship's progress. "You've got some good men



Much signalman training is conducted from the signal shack at FTG. An I/O hoists a set of pennants during a drill with an inport ship.



“What else can happen to me today???”

Training continues after hours as a scene leader instructs his men on some of the finer points of damage control.

on this ship, Captain, and they’re paying attention. That’s what we want,” reported one I/O.

“That’s what I’m concerned about,” replied the captain.

Thereafter, each ship’s performance is reviewed weekly in a conference with the COs. FTG personnel look for overall progress, allowing for an occasional bad day. All ships have them from time to time when they can’t “get it together.” That’s taken into consideration, but if the backsliding continues, extra training is in order.

Though the pace is hard on crews —“We’ve been at it 16 hours a day for more than a week,” lamented one sailor—it’s equally hard on I/Os. No man is expected to keep up a 12-hour per day pace for an entire two-year tour of duty. Consequently, I/Os usually get underway three days each week and ships in training don’t draw the same I/Os each trip out. This benefits the ships as well as the instructors by affording crews the opportunity to draw on the experience of many I/Os during the course of training. I/Os, in turn, are able to



Heading back into port after a hard day of training. Many days a crew will leave before dawn and return after sunset.

During Rescue and Assistance drills, it is not enough to have the gear on the pier in time. It also must be in sound working order.



work a somewhat normal schedule by having two and a half days on shore weekly.

It's a learning experience for them also. "We come to FTG as an expert in one area," said a warrant officer I/O. "By the time we leave, we're usually well versed in three or four due to our association with fleet sailors and other FTG instructors."

On the morning of the first graded drills, I/Os arrive at the quarterdeck

about 30 minutes early. Their counterparts on board meet them and the inspection begins.

Watertight fittings are checked, discrepancies signed off and training problems, thus far, hashed out. The engineering I/O checks out his spaces and reports to the captain, "Captain, you are ready to go to sea for training."

Once the graded drills begin, a personnel injury can be expected at any time to test any crew member's knowledge of first aid. The first casualty, in one instance, happened on the bridge. A sailor with a chalk white face staggered in and fell by the helm. Before he hit the deck, it was obvious he had a stomach injury—his

(fake) "intestines" hung from his shirt and "blood" (a concoction of chemical coloring) soaked his clothes.

The OOD treated him quickly and correctly. "Most crews have a good idea what to do in case of a casualty," said the corpsman I/O. "Once it has been impressed on them that their corpsman or doctor could get killed or injured, they learn fast. By the time they leave Gitmo, they can easily pass a basic first aid course."

Incessant drilling takes its toll in strength and tempers, but with each new try, the results get better. "It's a beautiful thing," commented one ship's captain, "to watch your crew



The I/O is physically on the scene during each drill to instruct and correct as needed. It is more important that correct procedures are learned than it is to get a good grade.

Every man on board is required to know the basics of first aid. Here, knowledge is tested when a sailor stumbles onto the bridge "suffering" from a stomach wound.

being transformed from individuals to a team; changed from persons going their own way to a team working together. My experiences at Gitmo have convinced me that I/Os here are real professionals."

"I've been here four times," a senior chief boatswain's mate said, "and every time I've learned something. I'm good at my job, but I always learn more."

You can't help but learn something. "Most of the people who come here," said a senior I/O, "have the knowledge to pass a routine inspection. We try to delve deeper, though, so if

An I/O's day can start as early as 0500 and last until late in the evening. Here, an inspection of ship's records by damage control and engineering department I/Os draws rapt attention, and at least one chuckle.



a ship is faced with a real emergency the crew won't choke—they'll know their jobs. Some sailors say this is nit-picking. We don't think so. It's either right or wrong. The complainers are usually the ones who don't know their jobs inside out."

By the time the first drill is over and the ship is heading back to port, the crew is visibly exhausted. They've made mistakes and learned why their way of doing things is not as good as the right way. Their illusion that there is a "Gitmo way" and a "fleet way" has long since been deep-sixed.

The post-training briefing disclosed that the ship improved since the walk-

through, but the I/Os continued teaching. "All right, let's have some questions," one said. "Think. Think about what you've seen and learned today. This isn't a game; it could happen for real. What are you going to do if there is an oil spray fire in the engineroom and one of your buddies is injured, six others are dead? This is serious, full time business—Let's have some answers!"

And so it goes on. The training never seems to end and there is no time for relaxation underway. All too soon, though, refresher training does end—a grueling month is over. The crew notices very little change in themselves—it happened gradually with little time to think about it.

Still, several hundred sailors have lost their initial awkwardness and found a confidence that comes only from knowing their jobs thoroughly. The I/Os can see the difference.

Another Navy ship has made it. ⚓

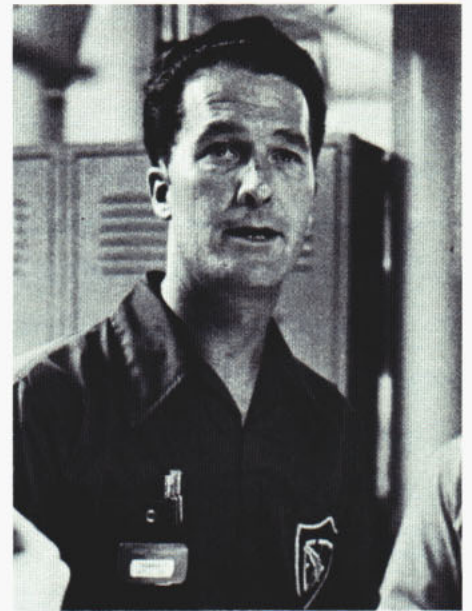

Gitmo I/Os usually ride ships in training three days a week and work on shore the other two and a half. Here, an I/O lectures an unseen audience on the merits of being prepared in case of emergency.



NEXT DANGER
BREATHING APPARATUS
TYPE A-3
MILITARY EQUIPMENT

a college for ships

BY JO2 DAN WHEELER

Navy ships changed in design and mission as wooden vessels gave way to iron and iron to steel, yet the basic methods of training Navy men remained virtually unchanged through the years. Historically, training in the fleet was accomplished through absorption of recruits into existing shipboard organizations. This method served the Navy well until the outbreak of World War II.

Early in the war, however, naval officials realized that the relatively small number of career Navy men couldn't meet the training requirements of ships being commissioned for the war effort. Navy professionals were spread thin throughout the fleet and old training methods rapidly proved inadequate for a growing sea service with worldwide commitments. Wartime conditions and the influx of predominantly untrained people demanded quicker and more effective methods of readying crews for battle.

Admiral Ernest J. King, Commander-in-Chief, U. S. Fleet, responded to the need by ordering the establishment of Fleet Operational Training Commands whose sole purpose was

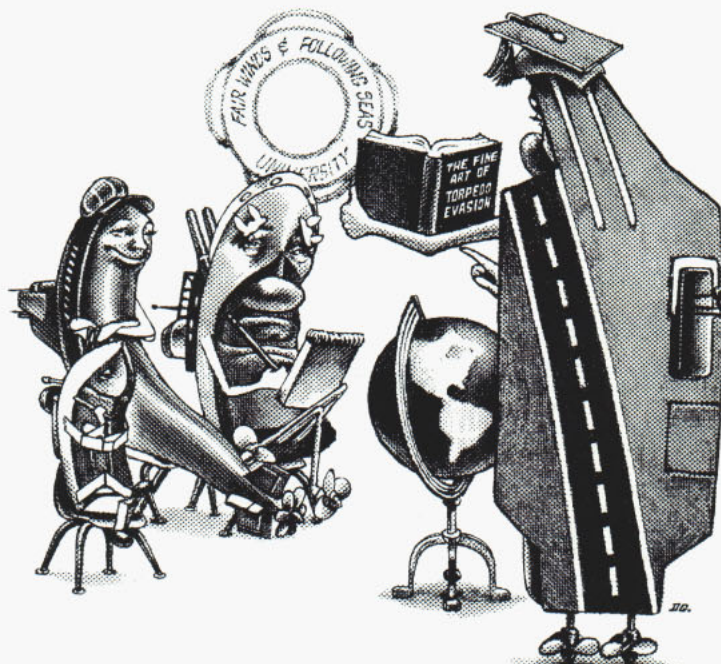

to schedule and supervise operational instruction during shakedown or initial cruises and periodic refresher training as required. The present day Fleet Training Group (FTG), Guantanamo Bay are the offspring of those early commands.

Established in August 1943 and renamed FTG in January 1946, FTG, Gitmo is responsible for providing realistic, combat-oriented, underway shipboard instruction. Emphasis is on evaluation and improvement of the various shipboard teams rather than directly increasing knowledge and skills of individual crew members. FTG also assists commanding officers in meeting operational and training standards imposed by their type and fleet commanders by using proven instructional methods, standards and procedures—everything taught is according to existing fleet doctrine and is not for use solely at Guantanamo.

At the end of 1958, FTG began training ships of friendly foreign nations in addition to those of MSTs, now MSC, U. S. Coast Guard and the Navy. With a staff today of about 100 instructor/observers and some 60 FTG support personnel, FTG trains the crews of 75 to 100 ships annually and makes available a host of facilities including:

- complete ship repair support
- ammunition and bulk fuel storage
- 6,500 feet of pier space
- two airfields

- services of a composite air squadron for training support
- medical and dental facilities
- fleet recreational areas and retail store outlets

Additionally, Gitmo has proven to be an excellent location at which to conduct any kind of concentrated shipboard evolution required by shakedown or refresher training. One major advantage of its location—though not always popular among crew members—is its isolation. There are few of the distractions normally present at stateside homeports which prevent sailors and instructors alike from totally immersing themselves into the strict training schedule.

Except for an occasional hurricane or tropical storm, Gitmo offers ideal weather year 'round for fleet operations. Within minutes of weighing anchor, any ship can be in deep water in a short time where any underway exercise from gunnery to ASW can be held. The 14,000-square mile training area is free of major air and commercial sea traffic, allowing freedom of movement to aircraft, ships and submarines involved in exercises.

“Training” has been the military mission of Fleet Training Group since its inception and has continued with only brief interruption for nearly 35 years. As long as the Atlantic Fleet requires a “school for ships,” Gitmo will be the alma mater awarding the diplomas.

Grains of Salt

Exploring the Arctic Ice Caps

BY LT TOM DAVIS

Eric the Red led the way with the discovery of Greenland in 985, but it wasn't until the late 15th Century that other European adventurers and soldiers of fortune followed by showing an active interest in polar exploration. Excited by the possibility of finding a northwest passage to the Far East—and tales of jewels and emeralds scattered on the oriental beaches—Europeans organized numerous expeditions during the next 350 years attempting to discover the elusive route connecting the Atlantic and the Pacific Oceans.

Perhaps the most ambitious of the early expeditions was headed by Sir John Franklin of the Royal Navy in 1845. Setting sail with 129 men on board two ships, Franklin thought himself well-equipped to venture into the Arctic ice, but the hoary northern winter soon proved him wrong. His entire expedition perished when their ships became entrapped in drifting pack ice.

During the next 12 years, more than \$20 million was spent on 20 rescue missions ostensibly formed to determine the fate of Franklin and his men. Between 1850 and 1873, three major American expeditions entered the search. One was commanded by Navy Lieutenant Edward DeHaven; two others by Navy surgeons, Elisha Kent Kane and Isaac Israel Haynes. Although a wealth of scientific information about the lands and waters of the eastern Canadian Arctic and the west coast of Greenland was collected, few traces of the ill-fated Franklin Expedition were ever found.

Of all early Arctic explorers, both

European and American, one man's work dominates the history of Arctic exploration—Robert E. Peary, a U.S. naval officer. In 1892, Peary established for the first time that Greenland was an island, and during the next 40 years he travelled farther north and added more to the knowledge of Arctic geography and survival methods than any other man of his generation. On April 6, 1909, after 13 years of obsessive work, eight separate expeditions and nine winters in the Arctic, Peary realized his life's ambition when he and five companions became the first men to reach the North Pole. For this magnificent achievement, Peary was promoted to rear admiral.

Seventeen years later on May 9, 1926, another Navy officer, Commander Richard E. Byrd, made history when he and his co-pilot Floyd Bennett flew their tri-engine *Fokker* over the North Pole for the first time. Three years later, Byrd again made history when he became the first man to fly over the South Pole. From his first trip to Antarctica in 1928, Byrd continued active exploration and research for more than 28 years. He not only took part in the International Geophysical Year in 1956, but also directed the exploration activities of the Navy's Operation Deep Freeze I in the same year. Deep Freeze Operations have continued uninterrupted to this day.

Byrd, however, was not the first American to take an expedition to the southern polar cap. The credit for that belongs to another Navyman, Lieutenant Charles Wilkes, who became America's first polar explorer nearly 100 years earlier.

During the first 20 years of the 19th Century, U. S. interest in the area south of Cape Horn waxed as sealers and ship owners became concerned that America was falling behind Europe in the race for fishing and sealing grounds, new trade routes and bases in the area. In 1821, pressure was put on Congress to appropriate funds to outfit a naval expedition to explore the Antarctic waters, but 15 years passed before legislation was finally enacted.

On May 14, 1836, the United States Exploring Expedition was authorized. Another two years passed before it set sail from Hampton Roads, Va., under the command of LT Wilkes in six vessels in such poor repair that only two survived the four-year voyage.

During three forays into Antarctic waters proper, Wilkes was able to sight enough points along the 1500 miles of icy coast to establish that Antarctica was indeed a continent and not a group of separate islands as previously supposed.

Perhaps the most dramatic moment in modern U. S. naval polar exploration came on March 17, 1959, when USS *Skate* (SSN 578) surfaced through the ice at the North Pole. Four years later on August 2, 1963, *Skate* again made history when she rendezvoused with USS *Sea Dragon* (SSN 584) under the ice at the North Pole. These sub-Arctic achievements demonstrated that the Arctic Ocean is not only accessible under the ice cap, but is actually an operational area open to nuclear submarines regardless of season. After nearly 500 years of searching, the northwest passage had been found, with the North Pole thrown in to boot.

"The Soviet Union is systematically building forces at a steady rate to provide its political leadership with the political and military options afforded by a large, powerful and flexible navy. Our main adversary is on the move to capitalize on the use of the sea as another and, for them, a new area of competition with the West."

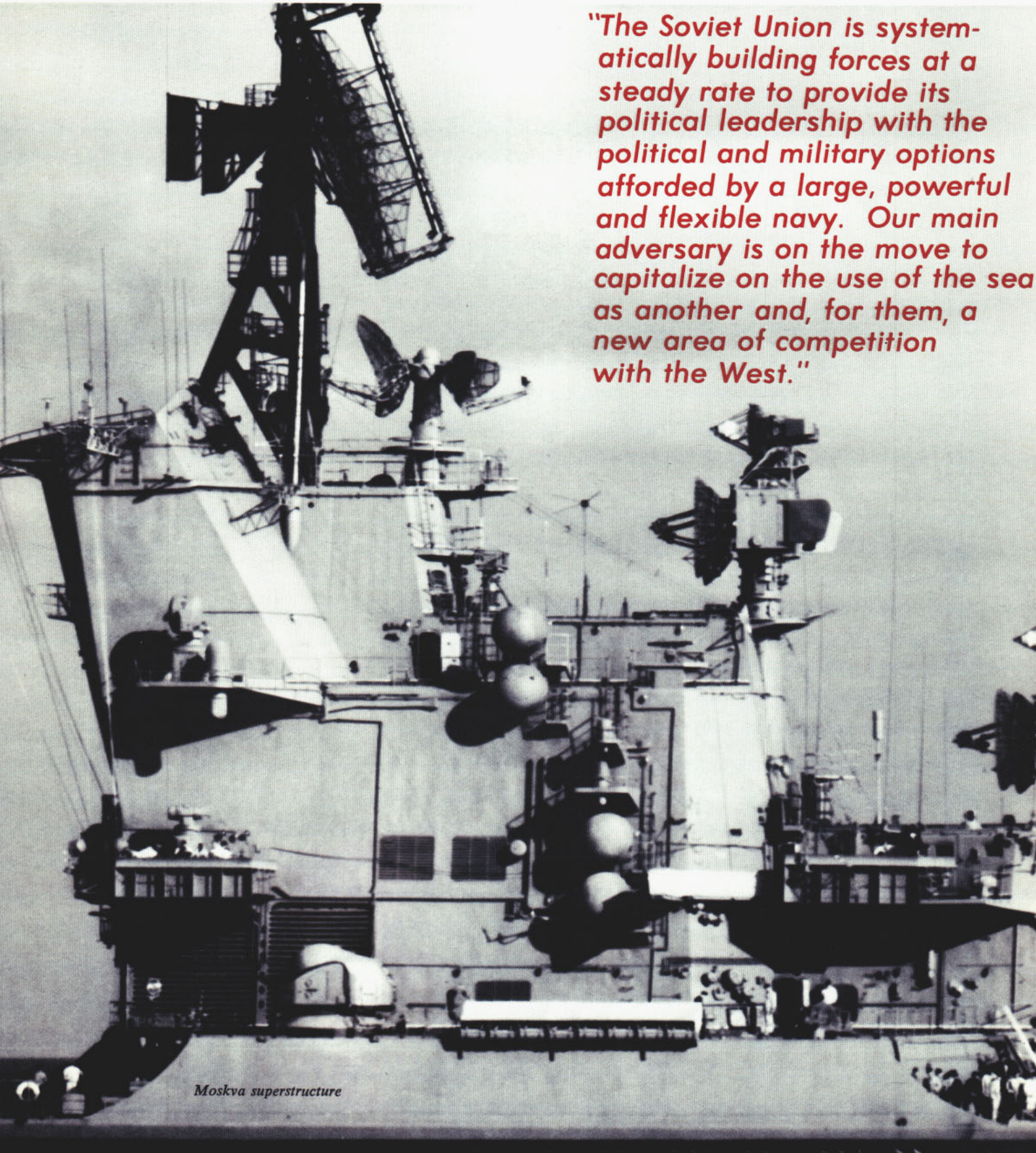

Moskva superstructure



The Soviet Naval Challenge

Searching for New Red Seas

ALL HANDS recently visited Rear Admiral Donald P. Harvey, Director of Naval Intelligence, to discuss the growing Soviet naval threat to U.S. national interests. Following is the transcript of the conversation.

- Q.** Admiral Harvey, a topic of increasing concern to many Americans is the growing Soviet naval challenge. Is there any way of measuring their Navy against our own?
- A.** Unfortunately, there's no easy way to do that because there are so many variables in the comparison. Some people compare numbers of ships and weapons, but that's just one factor, and it can be misleading. Actually, on paper, the total number of units in the Soviet inventory has been gradually decreasing over the past few years; yet their capabilities are increasing.
- Q.** How can that be?
- A.** Because they are replacing larger numbers of older, less capable units, such as small surface combatants and diesel submarines, with smaller numbers of highly capable units. And, the fastest growing areas of the Soviet Navy are the ones that give them the greatest capabilities. Notable among these are the capability to push their maritime defense farther into the open ocean; to deny use of the sea to others far from their shores; and to support their national policies worldwide.
- Q.** Could you give some examples of those areas where the Soviet Navy is expanding in both capabilities and numbers?
- A.** They include sea-launched ballistic and cruise missiles, nuclear-powered submarines, high endurance surface combatants with missile capability, sea-based aircraft, supersonic missile-carrying strike aircraft, ocean-going amphibious ships and underway replenishment ships. (→)

*Right: Soviet Victor-class nuclear submarine in the shadow of U. S. patrol aircraft;
Opposite page: Yakovlev YAK-36 Forger fighter plane approaches Kiev's flight deck.*

- Q.** If raw numbers don't always give an accurate account of Soviet naval strength, how can the challenge best be measured?
- A.** One of the most relevant yardsticks is to evaluate the combat capabilities of individual Soviet naval units, and the ability of those units to fulfill their missions.
- Q.** How can we be sure what their missions are?
- A.** We can draw a pretty good estimate based on a number of factors. One is their basic needs with regard to the seas. We find those needs to be different from our own. We, and our allies, must depend on ocean commerce for our economic as well as our military survival. But the Soviets are essentially a continental power, and though they are increasingly exploiting the benefits of the sea, those benefits are not vital to their continued existence. Simply stated, the U.S. Navy must be prepared to control the sea areas required to fulfill our objectives, while the Soviets need only be prepared to deny us this use of the sea.
- Q.** Do the Soviets themselves give any clues as to how they plan to use their Navy?
- A.** Of course, their very activities give some indication. But, beyond that, the Soviet Naval leadership has been quite outspoken about their goals. This is particularly true in the case of Admiral Sergei Gorshkov, Commander in Chief of the Soviet Navy since 1955, and chief architect of its growth. Gorshkov speaks of broad ranging strategic

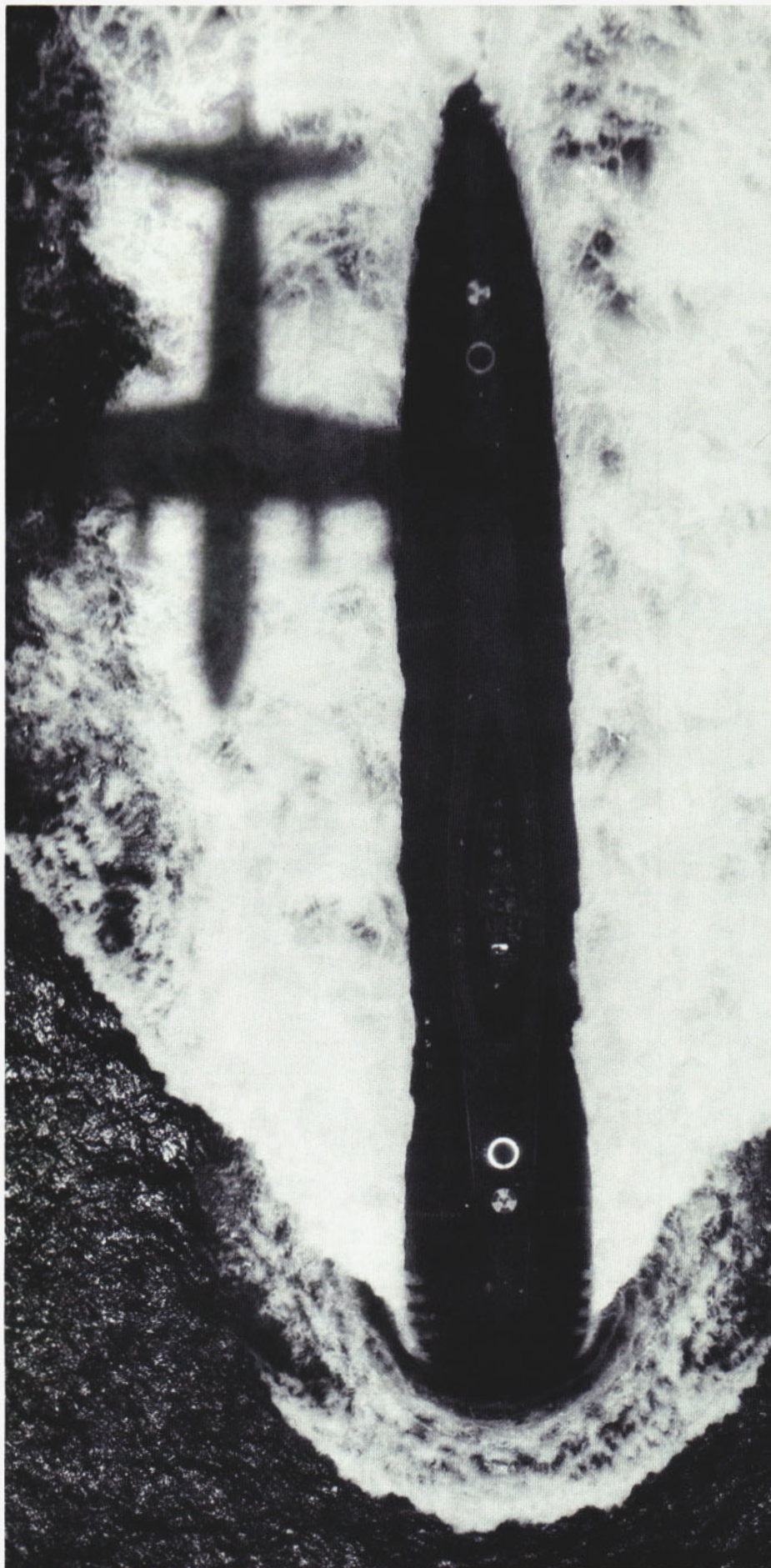

and tactical missions for the Navy in support of what he calls "the battle against the shore." To carry out such missions, he calls for a large "balanced force" capable of carrying out a wide variety of tasks. He envisions an expanding role for the Navy as a worldwide instrument of state policy.

Q. Based on all the available evidence then, what is the Soviet Navy up to? What are its missions?

A. I think we can discern at least five: strategic deterrence and strike; control of their sea frontiers; sea denial; seaborne projection; and support of state policy. Their capabilities in these areas vary; some are old missions, some are relatively new. But the sum total of their ability to perform each is the best yardstick we have of the Soviet naval threat.

Q. Has Soviet naval strategic deterrence received the same high

priority that it has in the U.S. Navy?

A. Over the last decade the Soviets have allocated considerable resources to their fleet of nuclear strike submarines and that trend continues today. In the past 10 years, they have completed 53 nuclear ballistic missile submarines. They added eight in 1976 alone—an extraordinary effort. They have 34 Yankee Class submarines, largely equipped with 16 SS-N-6 missiles with a 1,300-plus nautical mile range. There are now 19 of the more recent Delta Class subs, which carry the 4,200-nautical mile SS-N-8 missile. That range, by the way, is comparable to our Trident system which is not yet operational. Some DELTAs also carry the new SS-NX-18 missile, an improved version of SS-N-8 capable of delivering multiple warheads. Both the SS-N-8 and SS-NX-18 are capable of hitting most targets in the U.S. from Soviet home waters. In addition to the 53

modern nuclear ballistic missile submarines, the Soviets maintain a force of some 30 older ballistic missile subs—both nuclear and diesel powered. Today about 35 per cent of the Soviet strategic missiles capable of striking the U.S. are aboard submarines, and that percentage will probably grow in the future.

Q. What is the nature of the Navy's sea frontier control mission?

A. This is a traditional Soviet naval role in which they consider the Navy as an extension of their land defenses. The kind of forces assigned to this mission include their large mine warfare force, numerous amphibious craft, the naval infantry force, coastal defense units, segments of their naval aviation and surface combatant forces—many equipped with advanced missile and anti-submarine warfare systems. A notable feature of the Soviet sea frontier control mission is that modern technology has allowed them to extend their defenses far-



ther and farther from their shores.

- Q.** How does that differ from the sea denial mission?
- A.** Sea denial involves operations in waters outside those which the Soviets consider necessary to their defense. Relying primarily on their vast submarine fleet and their increasingly formidable land and sea-based air power, as well as their sophisticated principle surface combatants, Soviet sea denial operations could seriously threaten U.S. and allied sea lines of communication. Modern nuclear attack submarines such as the November and Victor classes pose a substantial sea

Right: Kotlin class destroyer trails in the wake of the fast frigate USS Bradley; Below: Kythera anchorage in the Mediterranean, showing units of the Soviet fleet.

denial threat. Surface combatants like the Kara and Kresta class cruisers, Kashin and the Krivak destroyers provide a large back-up force to the submarine and air sea denial forces and are a necessary part of the "balanced" Navy as perceived by Admiral Gorshkov. Undoubtedly, some of the most dramatic recent developments in this area have involved Soviet naval aviation. Their new supersonic Backfire bomber, now operational, represents a significantly improved capability, permitting anti-ship operations over the north Atlantic sea lanes, as well as those to the western Pacific.



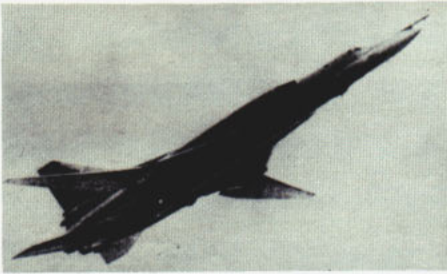

Left: Backfire supersonic bomber has greatly improved capabilities over its predecessor, the Badger; Below: Kamov Ka-25 Hormone ASW helicopter in flight near Moskva class helicopter carrier.



- Q.** What's the significance of their new aircraft carrier, the Kiev?
- A.** Kiev and its embarked vertical short takeoff and landing aircraft mark the beginning of a new era in Soviet naval development. The Soviets call Kiev an Antisubmarine Warfare Cruiser, reflecting their concern for U.S. submarine capabilities. The fact is, they have designated all principal combatants built since 1968 as ASW ships of one type or another. Kiev's 35 aircraft, which include Forger VSTOLs and Hormone helicopters, represent only one aspect of her capabilities. She also has at least two sonars, a nuclear-capable ASW missile launcher, ASW rockets and torpedo tubes, eight large surface-to-surface missile launchers, two twin-arm medium range and two twin-arm short range surface-to-air missile launchers, two twin 76 mm guns, eight small caliber gatling guns and extensive electronics and communications. That's some

weapons platform! And there are at least two more Kiev class carriers under construction.

- Q.** Aircraft carriers, then, would seem to fit into the Soviet Navy's seaborne projection mission?
- A.** Carriers could imply an interest in that role. Seaborne projection is the use of naval force to project power ashore. Although the Soviets now have little ability for projection against well defended areas distant from their shores, they are building forces that could be the beginning of projection power. Developments we are watching include an expanding oceangoing amphibious capability, their new carrier-based air strike potential, a growing merchant marine that is adaptable to amphibious support, their large fleet of multi-purpose surface combatants and a slowly increasing underway replenishment capability.
- Q.** The other Soviet naval mission

you mentioned was that of supporting state policy. Does that mean an increasing "show-the-flag" role for their units?

- A.** Yes, that trend is quite clear. Since the 1960s, the Soviet Navy has established itself in the seas of the world with forces operating regularly in the Mediterranean, the Indian Ocean and off the west coast of Africa. They also make occasional deployments of their combatants to the Caribbean. In addition, Soviet ships have made calls to an expanding number of ports throughout the world. Soviet naval reconnaissance planes use airfields in Cuba, Guinea and Somalia for staging operational sorties. Soviet intelligence collection, oceanographic research and space support ships deploy around the globe. Because of this greater worldwide naval reach, the Soviets are now in a position to narrow our naval options, while expanding their own in times of tension. (→)

Below: Krivak class destroyer Bodry in the English Channel; Right: Kiev underway in the Mediterranean.

- Q.** Greater reach would require greater access to support bases in distant areas, wouldn't it?
- A.** Yes, and Soviet interest in the state policy support mission is indicated here as well. They have acquired access to port facilities in the Mediterranean, the Indian Ocean, the Caribbean and West Africa. The loss of Egyptian port facilities last year caused them to seek alternate facilities, and they have made some increased use of Syrian and Yugoslav ports. They have also begun to use air facilities in Somalia.



- Q.** Admiral, to gain some perspective on the exact nature of the Soviet naval threat, would you identify some of their current strengths and weaknesses?
- A.** Let's start with the weaknesses. The Soviets' open ocean ASW capability is low. They presently lack a meaningful sea-based tactical air capability. Their strike and reconnaissance bombers are vulnerable to attack beyond the range of their land-based fighters. Their underway replenishment capability is low. And last, but by no means least, geography limits the effective use of their Navy. Major fleet areas are geographically separated and located great distances from the world's major sea lanes. Moreover, access to the open ocean is limited by narrow straits in the Black Sea, Baltic Sea and the Sea of Japan.

strategic submarine force, the largest general purpose submarine force, the largest mine warfare force and mine stockpile, and the largest shipbuilding industry in the world. Their extensive ocean surveillance system includes the largest fleet of ships dedicated to intelligence collection. They possess an advanced anti-ship missile capability which is spread among a variety of launch platforms—including ships, submarines and aircraft. Chemical, bacteriological and radiation defense measures are built into their ships and are regularly exercised. And, they are prepared to operate in a complex electronics warfare environment.

- Q.** Admiral Harvey, the Soviet Navy is clearly our most formidable threat on the high seas. How should U.S. Navy men and women view that threat, and what, if anything, can be done to counter it?
- A.** As professionals, we ought to look at the threat objectively,

- Q.** And their strengths?
- A.** First, possession of the largest



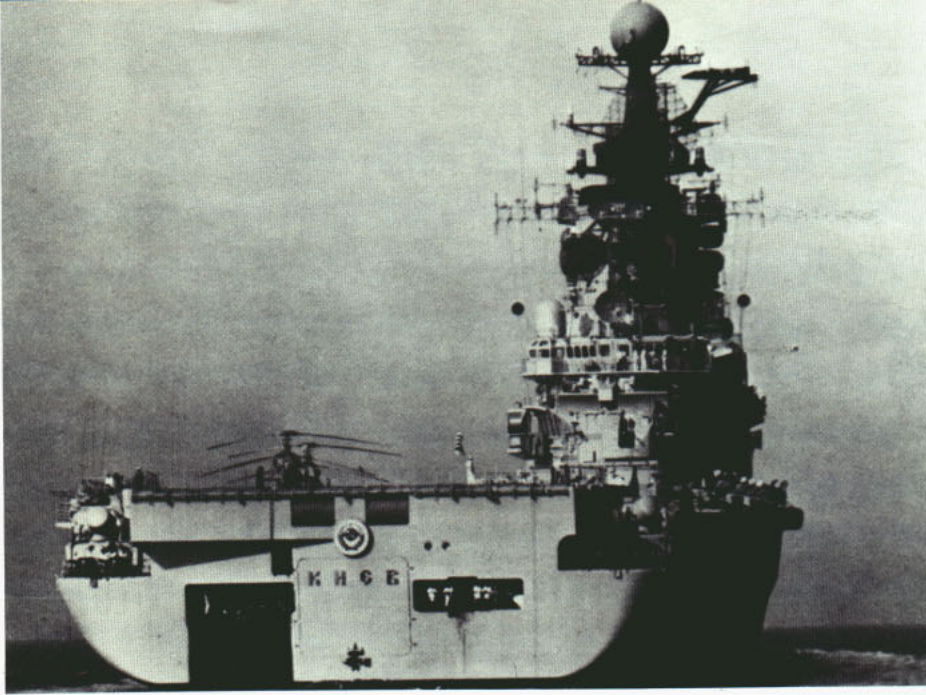

Below left: Moskva class helicopter carrier, right, refuels from Soviet fleet oiler Boris Chilikin.

based on facts rather than emotions. We should not discount the fact that the Soviet Navy lags the U.S. Navy in technology, combat experience, sea-based air power and overall quality of many systems. At the same time we should be aware, as should the American people, that our pri-

mary adversary is building a large, powerful, flexible Navy that provides their leaders increasing political and military options. The Soviet Union is clearly on the move to capitalize on the use of the sea as another (and for them a new) area of competition with the West. The other

side of that coin is a substantial rise in the complexity of the threat facing the U.S. Navy. We cannot stop the development of Soviet seapower. We can only meet the challenge to forestall a narrowing of the naval options available to the U.S., while tempering those available to the Soviet Union. ↴

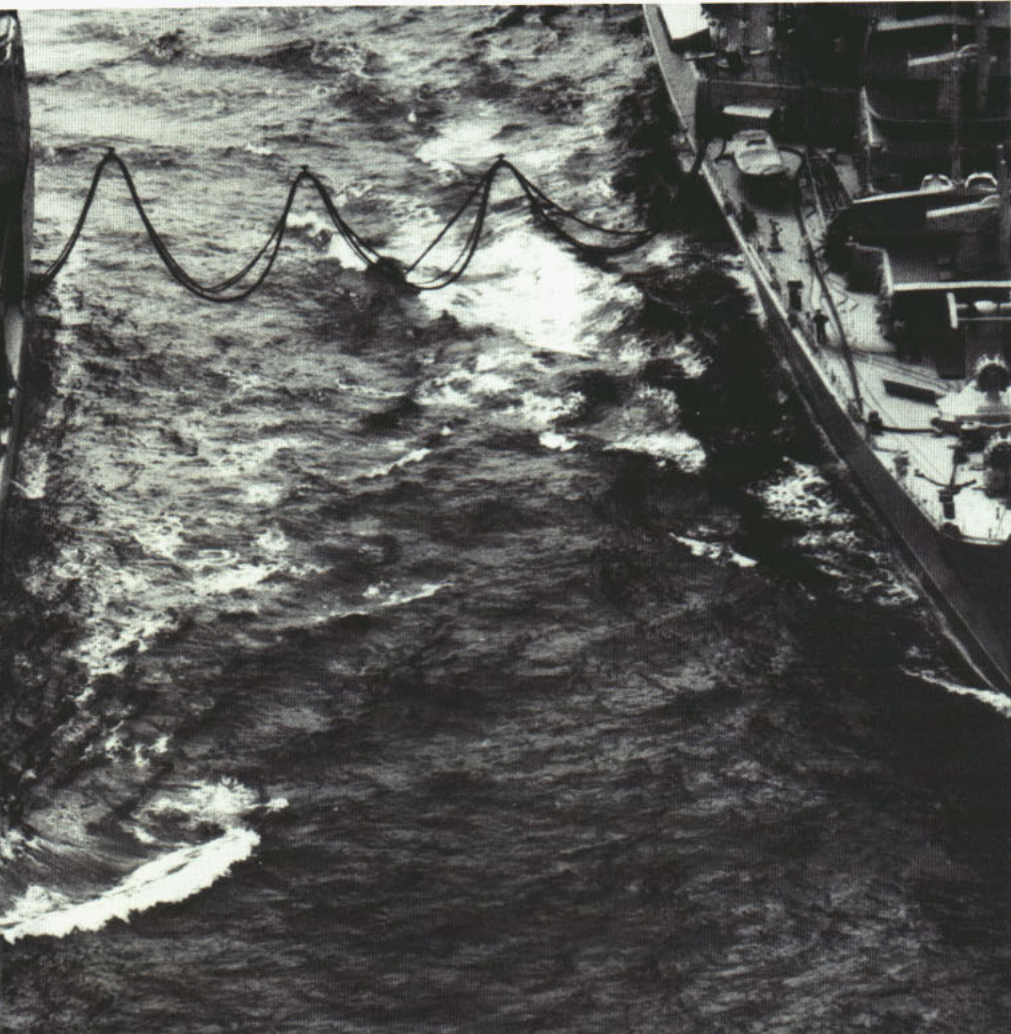

Rear Admiral Donald P. Harvey received a Bachelor of Science Degree from the U.S. Naval Academy in June 1947 and also holds two Masters Degrees from the Fletcher School of Law and Diplomacy. He became the 50th Director of Naval Intelligence on July 20, 1976, after serving as Chief of Staff and Director of Plans, Defense Intelligence Agency.

LIFE IN THE SOVIET

BY JO2 DAN WHEELER

"It interrupted my civilian career, but I find that inevitable," a Soviet sailor said of his tour in the Navy. Another, more inclined toward the Communist Party line, described his tour of duty as the "selfless taking up of arms in defense of the Motherland."

Both accept the Spartan life of the Soviet Navyman without complaint, though it's unlikely that either will serve longer than the mandatory three years.

And why should they? It's a demanding, exacting life where basic training begins many years before induction and "morale" means "political reliability." There is little basis for comparison between the Russian navyman and the American sailor. Here are some hard facts about the hard life of your Russian counterpart.

Life Aboard Ship

Only the most physically fit and best trained go to sea for their initial tour of duty; there is no sea/shore rotation during this period. Living conditions in newer ships are good—by Soviet standards—most have showers, mess decks and some air conditioned spaces.

Soviet Navy food is about the same quality as that served to workers in Soviet factories. Though selection is limited and culinary beauty ignored, no one complains—they expect no more.

Typically, breakfast is dried fruit heated and softened in water, brown bread and hot tea; lunch is similar—soup, bread and tea; and for dinner, dried fish, potatoes, bread and tea. Such capitalistic frivolities as chewing gum, candy, cookies and other geedunk are nonexistent. They're not even readily available at home, much less at sea. Compensating for the blandness of daily fare is a tea break each evening at 1930.

Berthing areas are divided into small living compartments, each sleeping about a dozen men. A single shelf in each space serves as mess, study and operating table in case of emergency. Warrants, officers and enlisted are segregated in this "classless" society, yet none have quarters equal to those in a U. S. Navy ship. Officers' staterooms are similar to the officer quarters in U. S. ships of the 1920s. There are a lot of wooden fixtures and they are somewhat cramped.

Newer vessels have heads with showers—a luxury not found on older Soviet men-of-war—and while at sea, according to an official Soviet publication, submarine sailors have it better, "The crew can regularly take a shower." Showers evidently double as laundry facilities since there are none on board, however, their main purpose is nuclear biological decontamination.

It would seem that Soviet sailors rarely wash and never iron their two sets of wool blues though they are worn for liberty, work and inspection. Comfort and habitability are not high on the list of Soviet priorities.

There are no ship's stores comparable to those on U. S. vessels. Uniform replacements are evidently taken care of by the government; toothpaste, soap and other toiletries are issued in sickbay. Luxury items such as watches, cameras and jewelry simply are not available—even if they were, few sailors could afford them.

An internal radio system plays popular and classical music as well as an ample supply of political indoctrination material throughout the day, and—on birthdays—the pre-recorded voices of relatives wishing their favorite sailor many happy returns. (Birthdays are no small matter; the ship's cook bakes a cake and the entire crew joins in the celebration.)

Idle chit-chat, card playing and other frivolous uses of





time are frowned on; certain types of approved recreation are scheduled. Every hour of the seven-day work week is earmarked for some "useful" activity—any free time is usually usurped by the political officer. Hours not spent doing ship's work are used in learning Soviet history and philosophy (according to Lenin) or studying rating (specialist) requirements.

Underway watches are stood in much the same manner as those in the U. S. Navy and the typical day is not dras-

tically different:

Reveille is at 0600 followed by calisthenics at 0630; breakfast at 0700 and turn-to or political classes from 0800 until 1300 when lunch is served. Following the noon meal, the crew turns-to until dinner at 1800. Between 1800 and taps at 2300, either more political lessons, ship's work or "constructive" recreational time is scheduled.

Much emphasis is placed on learning the history of the Soviet Navy. Each crew member is expected, and strongly

encouraged, to learn about his ship's combat record and honors awarded her. Frequently, the entire crew spends thematic evenings in the ship's martial museum studying their ship's exploits, charts of her past cruises, photo albums and the lives and deeds of heroes drawn from her ranks. Each is urged to live up to the glory accorded his predecessors (those names are never removed from their ship's roster).

It's traditional for Soviet ships to lower their colors when passing over the coordinates where another Soviet warship sank in battle. During a solemn ceremony, the crew listens to an officer recite the story of the heroic ship's contributions to the Soviet cause and, finally, a commemorative wreath is tossed ceremoniously over the side.

Promotions, Pay and Liberty

Every Soviet sailor does a particular job and only that one job. It may be maintaining a specific piece of gear or painting the ship's side, but that is his only assignment during his initial tour. Even though the Soviets have begun some cross training in recent years, each sailor is responsible for training his own replacement. He may not be released from active duty until his replacement can perform satisfactorily.

(Unless a sailor attends an advanced specialist school, this on-the-job training is the only hands-on instruction he will receive.)

Every sailor tries to win at least three special badges or pins: one as a specialist (3rd, 2nd, 1st and master); another

Sailors who are technically proficient, politically enthusiastic and well-disciplined are encouraged to make the Navy their career, though less than 10 per cent do so.

for the Komsomol, a political achievement pin; and an outstanding conduct award. Specialist pins are designators of technical proficiency and not indicators of rank (though pay is affected by specialty at least as much as rank). Rank is determined by time in service and advancement is more or less automatic. Pay is based on a number of factors but the average recruit earns about \$10 a month to start and can earn as much as \$35 a month by the end of his three years.

Sailors who are technically proficient, politically enthusiastic and well-disciplined are encouraged to make the Navy their career, though less than 10 per cent do so. As a reenlistment incentive, qualified sailors are offered the rank of Michman (warrant officer). Michmans have better quarters, more pay and responsibility and the opportunity to be advanced to regular officer ranks after advanced schooling.

Junior officers do the work normally done by chief petty

officers in our Navy. They are the hands-on professional specialists who can handle most maintenance in their departments—enlisted specialists are actually little more than low level technicians (by U. S. Navy standards). During his early years of service, each junior officer is evaluated by his commanding officer for his potential to assume command at sea. If not judged to be command material, he will become a career specialist, continuing to rise in rank but limited to one field only.

Commanding officers of Soviet ships usually choose their own successors. Each selects his executive officer from among the department heads; the XO has the opportunity to be tutored by the captain and take the command-at-sea test. If successful, he will be given command of his present ship when the captain is transferred, or command of a ship of the same class.

While the Soviet Navy officially endorses "one-man command," the captain (a line officer) is subject to strict professional and political checks. For instance, when an officer senior to the captain and qualified for command at sea rides his ship, the senior visitor may take the con while entering port and conduct training exercises. Additionally, the CO, as a member of the Communist Party, is liable to socialist criticism from the lowest ranking seaman in matters political. Constant interference by seniors and the shipboard political officer (ZAMPOL) along with criticism by subordinates tend to undermine the CO's authority and create a situation which stifles innovation, initiative and decisiveness on the part of commanders. In the past, political officers were not naval officers—now, however, there is a trend toward giving these officers some shipboard duties and experience.

Officers' pay structure is very complicated since it is based on rank, speciality, time in service, type of duty, position on board ship, etc. Pay is considered quite good by Soviet standards, however, and is equivalent to that of any highly paid Soviet professional. Because of the good pay and social prestige, most officers make the Navy their career.

Soviet warships make maximum use of every mile of every cruise. Every possible training situation is seen as an opportunity to make the crew more proficient. It is not unusual for a Soviet ship on a seven-month deployment to stay at sea for the entire seven months, although much of that time is spent at anchorage or tied to a buoy. Liberty for the crew is almost unheard of.

Liberty, when it does come, consists of several hours of shopping in a town near the homeport. A group of four or five sailors accompanied by an officer make up each liberty party. This is normal routine and is never questioned—the officer is simply the man in charge; every group must have someone in charge according to communist logic. The officer is not there to prevent defection as is thought by many westerners; he is simply the supervisor. Most Soviets would never consider defection.

Leave is another matter entirely. Most sailors don't get any during their first three-year tour. At most, an exemplary seaman will receive 20 days leave over a three-year period which he will more than likely spend at a Soviet recreation



camp. Married sailors rarely see their families during the compulsory service; single sailors have little chance of getting married. They don't feel that such regulations are unduly restrictive—it is exactly like what they have been trained to expect.

When a Navyman—officers or enlisted—reaches age 50, he can usually retire. Although his pension will usually be sufficient so that he will not have to find other employment, the state will continue to use his talents as an instructor or in some other military-related job. There are plenty of such jobs available, especially for men with skills and leadership experience.

Training and Politics

Every Soviet male (few women, it is believed, serve in the armed forces) receives 140 hours of intensive military training during his last two years of high school and is given the opportunity to join a DOSAAF (All-Union Voluntary Society for Assistance to the Army, Air Force and Navy), a military club designed to teach a specialty useful to the armed forces. His membership and particular interests usually determine which branch of the service he will join.

Regular naval officers receive five years of training in one of 12 Higher Naval Schools (roughly equivalent to the U. S. Naval Academy). Selection is based on previous academic and political achievement, and scores on competitive exams. It is also based on a subjective process ensuring that sons of Navy officers, politicians, prominent bureau-

crats, and career enlisted men will have a better than average chance for selection. Thus, by Soviet standards, the Soviet Navy officer is an urban, educated and advantaged youth.

There are more than 100 nationalities within the Union of Soviet Socialist Republic—15 of them considered major—and the vast majority of Navy officers are Slavs, the elite of Soviet society.

Each November, Socialist Competition begins throughout the service. Everyone in each ship's company pledges to meet some kind of politically advantageous goal during the coming year. For instance, a sailor may promise to read 300 pages of Lenin to earn his Komsomol pin—regardless of what is pledged, it will be done even if it has to be fudged for the record. Political pressure never subsides—each sailor is continually being urged to do something more for the party.

At the end of each cruise or at the completion of active duty, each sailor is given the opportunity to write for the record his thoughts about the Navy and the accomplishments of his ship. Most read something like:

"I have been deeply moved by the untiring efforts of the officers and men to fill their Socialist Competition quotas in the area of speciality development. Their dedication to the Motherland has made me realize what a great blessing it is to be a Soviet sailor . . ."

(Based in part on a Soviet Navy publication—*Life in the Soviet Navy* by V. Mordasov—and interviews with knowledgeable U. S. Navy authorities.) ⚓

The Heat Balanced Engine

“Rube Goldberg

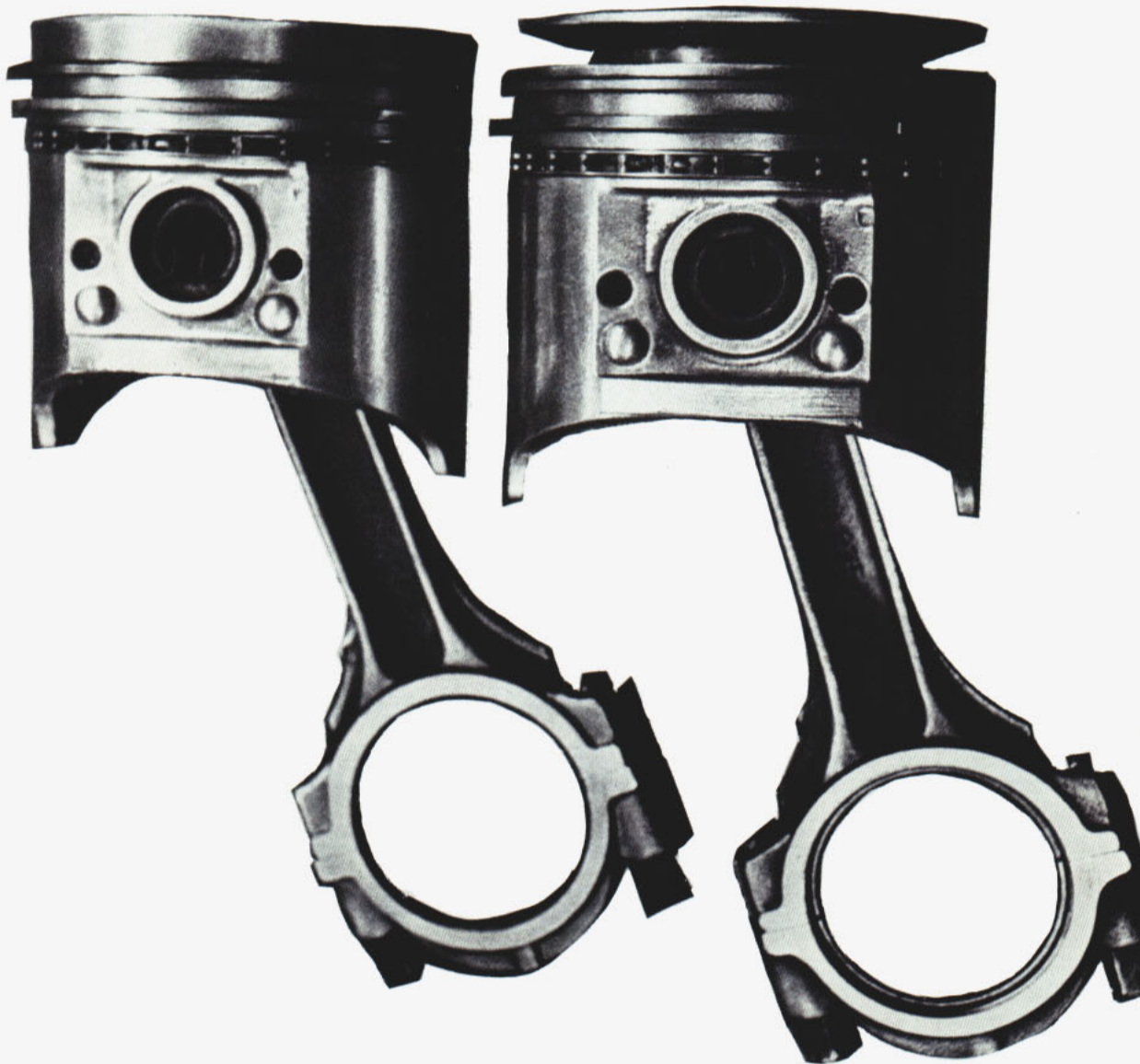

Would Be Proud”

STORY AND PHOTOS BY PH1 TERRY MITCHELL

Except for a few “Rube Goldberg*” devices, it looks like the old standard six-cylinder engine. Orange tubes, however, run from the brass thingumajig to the blue whatsit and back again, by way of the chrome widget. Not exactly your basic engine accessories.

This engine, developed at the U. S. Naval Academy, is an application of a theory that dates back many years in the history of the internal combustion engine. This theory purported that in order to make an internal combustion engine more efficient, you must lengthen the actual time of combustion in the cylinder.

Academy engineers, Dr. Andrew Pouring and Richard “Rick” Blaser, have demonstrated the theory with their engine, identified as NAHBE, or Naval Academy Heat Balanced Engine. The experimental engine achieves more efficient combustion through the addition of mushroom-shaped caps machined to the tops of the pistons along with a modified air/fuel intake system.

Standard internal combustion engine pistons have flat or domed tops which compress a mixture of fuel and air against the top of their cylinder. The ignition of the compressed mixture by a spark causes an explosion that thrusts the piston downward. The caps which Pouring and Blaser added to the piston tops accumulate a secondary reservoir of air underneath them. When the spark-produced explosion occurs above the cap, the air previously trapped underneath is fed out into the cylinder, prolonging time of combustion, and making it more efficient.

Before he came to the Academy, Blaser had experimented since 1971 with various types of engines. First experiments

involved the addition of perforated caps—not unlike bathtub strainers—to the tops of the pistons. Cap after cap of different sizes, types and patterns of perforations failed in both theory and mechanically. Finally, Blaser tried placing a solid cap on the piston. Success! He finally had achieved what others had been trying to do for years.

Taking his still crudely modified engine to major automobile manufacturers, he received little encouragement. Dr. Pouring, believing Blaser’s engine showed promise, formed a research team with Blaser and a few other technicians at the Naval Academy to further the development. Blaser was hired as a contract researcher.

The team pursued the theory further, refining the cap and redesigning it; it soon resembled the shape of a mushroom. Using a single-cylinder test engine on the Academy’s small dynamometer as a basis for the experiments, the team refined the engine through still more designing and modifications. The engine’s operation confirmed their expectations— increase of efficiency up to 40 per cent with more than an 80 per cent reduction in carbon monoxide and unburned

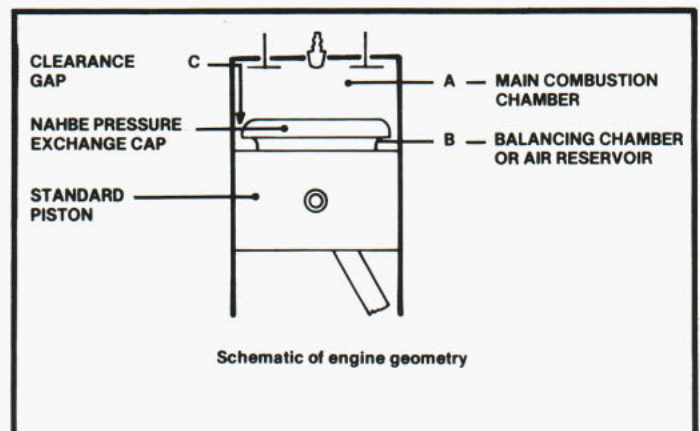

* Rube Goldberg (1883-1970) was famous for his cartoons of mechanical contrivances whose humor was derived from their absurd, unnecessary complexity.

hydrocarbons (the biggest source of pollution by the automobile).

The time had come to apply the principles demonstrated in the laboratory to an engine in a four-wheel vehicle. Strictly a low budget operation, the team searched and finally found an old Army M-151 jeep in the scrap heap at nearby Fort Meade, Md.

The 10-year-old vehicle was towed to the Academy and rolled into the basement of Melville Hall where transformation would begin. First the jeep's engine was removed and completely disassembled. The pistons were sent to the nearby machine shop for necessary modifications. The piston was first machined down at the top, a weld was added to the top, and then machined to form the required cap.

The intake manifold was then modified to accept extra air inlets. Small air accumulators were threaded into the holes to provide extra air which is required by the engine. A heater water valve, from a late model car, was pressed into service as a regulator for the extra inlets.

With assembly completed, the engine was re-installed in

**“Just for kicks
we ran it
on peanut oil.”**

the jeep. The body also underwent a few changes, mostly in the form of a paint job.

Rolled out of Melville Hall, the jeep was ready for the first test runs; it responded to the turn of the starter. The NABHE jeep was off. After a few short spins, it was evident that the engine functioned like the laboratory engine.

With slightly more horsepower and far more torque, the NAHBE-equipped jeep began to do some amazing things. A hill climb was conducted; the jeep bounced and jounced its way through the climb at idle. Transmission gear selection was no problem as the jeep pulled out in third gear.

One local skeptic conducted the same test with four passengers aboard. He then stopped and tried again, this time in fourth gear. With a slight strain, the NAHBE jeep chugged away, making the driver a true believer.

The blue and gold jeep now awaits other demonstrations and future modifications to its fuel system.

Lab research continued on the universal, standard, single-cylinder Combustion Fuel Research engine, modified to simulate the full-scale NAHBE. Study of possible fuels—alcohol, water and alcohol, alcohol and gasoline, diesel fuel—was undertaken. “We studied anything that burns,” said Dr. Pouring. “Just for kicks, we ran it on peanut oil. The engine didn't like it because the peanut oil is so thick and we were reduced to putting it in with an eyedropper.”

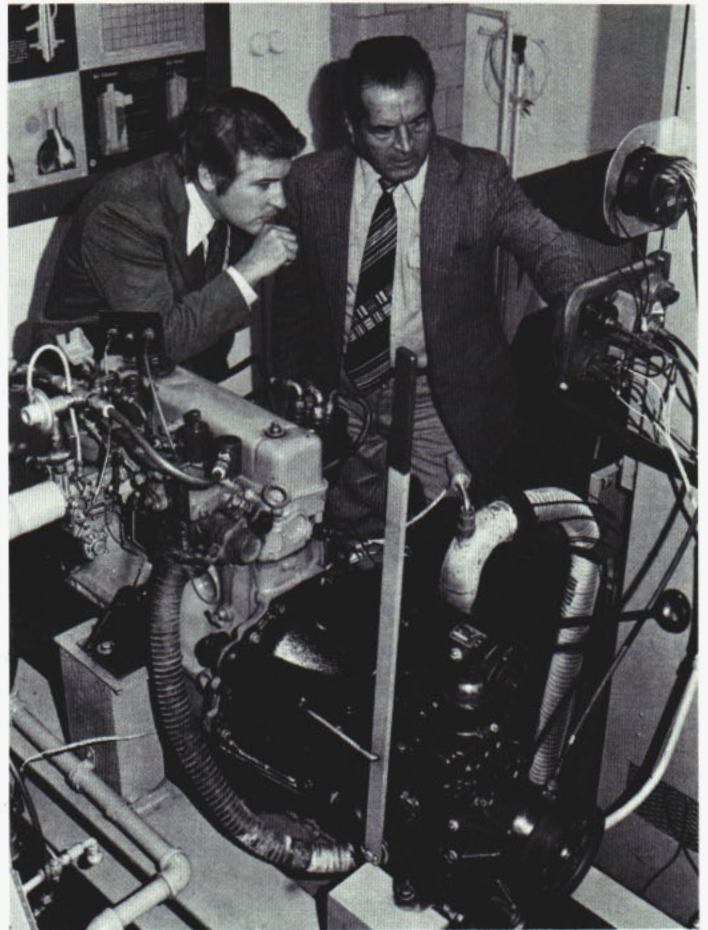

"Anyway," he continued, "I sent my wife to the market to buy a quart of peanut oil just for the test, and it cost somewhere around \$1.37."

Besides the wide variety of fuels which can be used, the NAHBE has other benefits as well as applications. For one, pressures at the moment of combustion in the cylinder are lower, putting less strain on the engine's bearings. Thus, the bearings do not wear out as fast and the engine's structural strength can be less, thereby making it lighter than a production model of a regular engine.

Conversion of the Navy's P-250 fire pump to diesel fuel operation is one thing the researchers are considering. Again, owing to the efficient combustion process of the NAHBE, engines with the NAHBE modifications can be run as diesels or on regular gasoline. This conversion would give the fire pump the flexibility of running on two basic fuels. In addition, the pump would be quieter and would run smoother. "Quieter and smoother operation in the Navy's point of view is an immediate gain for diesel type operations, especially for use in auxiliaries onboard ships," said Dr. Pouring.

Seeking to measure the NAHBE's success against other engines, the team took a partly modified engine to a consulting company in Springfield, Va., for testing against the Environmental Protection Agency's (EPA) standards for automobile emissions. The NAHBE scored well under the EPA standard of 15 grams per mile of carbon monoxide emissions with only about 7.3 grams per mile. "This performance is due to the fact that the NAHBE basically

changes the combustion process," according to Rick Blaser.

This also eliminates the need for exotic and expensive treatment of the exhaust gases, namely a catalytic converter.

Efficiency in combustion also means less fuel usage. "And, octane rating of a fuel has no meaning in this engine," said Dr. Pouring.

Blaser stated that based on existing data, that would mean anywhere from a 15 per cent to 40 per cent gain in every barrel of crude oil refined into fuel for the NAHBE type engine.

The brass thingumajigs, chrome widgets and blue what-sits work along with a mushroom cap. No, not your basic engine accessories—perhaps that's still in the future. We like to think Rube Goldberg would be proud of this one.



*Far Left:
Dr. Andrew Pouring and Rick Blaser,
co-developers of the NAHBE, monitor a
dynamometer measuring engine performance.*



*Above:
Trident Scholar Midshipman 1st Class
Tim Whited, Dr. Pouring and Rick Blaser
discuss Tim's project, a square-cylinder
engine using NAHBE modifications.*

*Left:
Rick Blaser in the driver's seat of NAHBE
I, powered by the engine that he and his
associate, Dr. Andrew Pouring, developed.*

Rights & Benefits

New CHAMPUS Guidelines Are Issued

Navy dependents and retirees have one of the most comprehensive health care plans in the world at their disposal—Champus (Civilian Health And Medical Program Of The Uniformed Services). Under provisions of Champus, dependents of active duty, retired and deceased Navy people are eligible to receive medical care from a number of civilian medical facilities and physicians on a cost-sharing basis.

Though Champus covers many maladies and provides for treatment at numerous medical facilities, there are exclusions and conditions which must be met in order to qualify. Misunderstandings about these exclusions and requirements have caused some Navy families severe financial hardship; they were forced to pay expensive medical costs because Champus requirements had not been fulfilled.

In other cases, Navy people who were eligible for Champus did not take advantage of the program because they were not aware of their eligibility and consequently bore the entire expense of treatment at a civilian facility.

In an effort to minimize such occurrences, Champus officials are currently distributing specific, easy to understand guidelines Navywide for use in base newspapers, and a new instruction (DoD 6010.8) has been written which outlines the entire Champus package. Individuals with specific questions about benefits, or their own eligibility, should still contact their Champus representative at the nearest Uniformed Services medical facility before seeking treatment.

Space doesn't permit ALL HANDS to publish specific exclusions and requirements under Champus. In an effort, however, to minimize misunderstandings about approved treatments, the following list of covered illnesses and available health care is offered. The list doesn't outline specific Champus requirements in detail; a Champus representative upon request will fill you in as they apply to your particular circumstances.

- **TREATMENT FOR ALCOHOLISM**—Champus will share the cost, up to seven days, for inpatient hospital care required to detoxify a beneficiary during acute stages of alcoholism when the beneficiary suffers from delirium, confusion, trauma, unconsciousness and malnutrition, and is unable to function. Such detoxification usually takes from three to seven days.

Benefits related to treatment of alcoholism—detoxification and rehabilitation—are limited to 21 days per episode. Champus will share the cost for no more than three rehabilitative stays during a beneficiary's lifetime. There is no limit, however, on the number of inpatient stays for detoxification.

- **SURGICAL ASSISTANCE BY A PHYSICIAN**—Champus will share that cost, provided the procedure was

complex enough to require a surgical assistant to be present and provided, also, a qualified intern or resident was not available. These restrictions are imposed as part of Champus' overall emphasis on assuring that payment is made only for care actually necessary.

- **SUCCESSIVE INPATIENT ADMISSIONS**—To give servicemembers a financial break, Champus regulations provide that successive inpatient admissions for their spouses or children will be considered as one confinement in computing their share of inpatient charges, provided no more than 60 days have elapsed between admissions. Exceptions are: successive inpatient admissions related to a single maternity care episode will be counted as one confinement regardless of the number of days between admissions; a maternity admission or an admission related to an accidental injury will be considered separate confinements and cost shared accordingly.

- **STUDIES, GRANTS AND RESEARCH PROGRAMS**—Champus will not duplicate payments when medical care is furnished as part of a scientific or medical study, a research program, or a program funded by a grant.

- **PSYCHOTHERAPY**—Champus will share the cost of one hour of psychotherapy treatment during a 24-hour period, up to a maximum of five one-hour sessions per week for inpatient care and two one-hour sessions per week for outpatient care.

- **PRIVATE ROOMS**—Champus will share the cost of private rooms only when there is a valid and acceptable reason for not using a semi-private room. Such reasons are outlined by Champus and any Champus representative will explain them.

- **PRIVATE DUTY (SPECIAL) NURSING**—Champus will share such cost if certain requirements are met. Details are available from any Champus representative.

- **STANDARDS FOR HOSPITALS COMPLIANCE WITH CIVIL RIGHTS ACT**—Champus will share cost only for care received from hospitals meeting its standards. Furthermore, it shares costs only for care from hospitals that do not practice discrimination on the basis of race, color or national origin—those that comply with Title VI of the Civil Rights Act.

- **CUSTODIAL CARE**—Custodial care is excluded from the Champus benefits package. Generally, custodial care is long-term care provided primarily to support the essentials of daily living in situations where the patient must have a protected, monitored and controlled environment. Champus will not share any related expenses with the exception of prescription drugs and medicines, and one hour of skilled nursing care per day (when such care is necessary).

• **DENTAL CARE**—Dental benefits are limited to care medically necessary in treating a medical problem covered by the program, and is essential for controlling that problem.

• **ORAL SURGERY**—Such treatment performed by a physician or oral surgeon is considered as medical care, not as dental care. Champus will not, however, share the cost of preparing the mouth for dentures, nor for removal of unerupted teeth, teeth that are partially erupted, teeth that are not in their normal position, or impacted teeth. Orthodontic work is also excluded except as related to correction of cleft palate.

• **COURT-ORDERED CARE**—Champus doesn't share the cost of court-ordered medical services or supplies.

• **PREVENTIVE CARE**—Generally, Champus will not share the cost of preventive care such as physical examinations, immunizations and screening procedures when no symptoms are present. Exceptions are outlined in the Champus instruction (DoD 6010.8).

• **PHYSICAL THERAPY**—Champus will share the cost of several physical therapy sessions per week when it is provided by a physician or by a registered physical therapist under supervision of a physician. These benefits are generally limited to a 60-day period for each illness or injury.

• **MILITARY SERVICE-CONNECTED ILLNESS OR INJURY**—Champus benefits are not available for such care—VA administers a program to cover this.

• **MATERNITY COST SHARING** — Champus will share the cost on an inpatient basis for all services and supplies related to a maternity care episode when an expectant mother plans to have her baby at a civilian hospital or similar medical facility. The only exception to this rule is ambulance service which is always cost-shared on an outpatient basis. Consult the Champus instruction or your representative for specific details about this provision.

• **EYEGLASSES**—Champus usually will not cost-share for eyeglasses, spectacles, contact lenses or other optical devices. Exceptions involve optical devices required as a result of surgery or serious eye damage.

• **DUAL COVERAGE**—Active duty service members are not eligible for benefits under Champus even though they may be dependents of eligible Champus recipients. Active duty members are covered under the Uniformed Services Medical Care System.

• **DOMICILIARY CARE**—This is care provided by an institution where the facility serves as a "substitute home"—it is not medically necessary for the care to be provided by an institution. An example of this is an extension of a hospital stay beyond the time considered medically necessary because the beneficiary lives alone. This is excluded under Champus cost sharing provisions.

• **DIAGNOSTIC ADMISSIONS**—This expense will be

shared by Champus on an inpatient basis when the diagnostic tests could not have been performed on an outpatient basis. Diagnostic tests which can be performed on an outpatient basis are cost-shared on an outpatient basis regardless of where the tests were actually performed.

• **CONTINUED ELIGIBILITY FOR AN INCAPACITATED CHILD AGE 21 OR OLDER**—Champus will continue to share the cost of treatment for a child over 21 provided the child cannot support himself because of mental or physical incapacity. There are exceptions to this coverage and your Champus representative should be consulted for details.

• **CONCURRENT INPATIENT PHYSICIAN CARE**—In illnesses involving one of the three following situations, specific guidance should be sought from your Champus representative to ascertain the exact limits of Champus coverage: same physician/different types of care given concurrently; different physicians/inpatient medical, only, given concurrently.

• **ANNULMENT, EFFECT ON ELIGIBILITY**—An individual whose marriage to an active duty member or retired servicemember is annulled loses Champus eligibility as of 12:01 a.m. on the day following the day on which the court granted the annulment order. Champus benefits received between the date of marriage and the date of annulment do not have to be reimbursed.

• **AMBULANCE SERVICE**—Champus will generally share this cost.

• **EDUCATION**—Champus will not share the cost of any service or supply for general education as in the case of natural childbirth, remedial reading and special tutoring classes.

• **DURABLE MEDICAL EQUIPMENT** — Champus shares the cost for a wide range of durable medical equipment under both its Basic Program and its Program for the Handicapped, provided that the equipment cannot be borrowed from a local Uniformed Services medical facility.

• **PRESCRIPTION DRUGS AND MEDICINES** — Champus will share the cost of all prescription drugs and medicines with certain exceptions, most of which involve weight control drugs, non-USFDA approved drugs and drugs used in drug abuse related situations.

• **COSMETIC, RECONSTRUCTIVE AND/OR PLASTIC SURGERY**—Champus will share the cost of such surgery when it meets the following criteria: corrects a marked deviation from the normal standard and it existed at birth (congenital anomaly); restores body form following an accidental injury; or revises a disfiguring resulting from cancer surgery.

• **PROGRAM FOR THE HANDICAPPED**—Champus will provide care for the physically and mentally handicapped when certain requirements are met. Consult your representative for details. ↓



'There aren't any **STOP**

BY JO1 JERRY ATCHISON

"I always think of it as playing double-deck pinochle," he said as he laid out a drinking-straw diagram on the table. "The only difference is we Navy Air Controlmen (ACs) have to possess the ability to remember every card played."

Navy Air Traffic Controllers are, by Navy standards, a small community of about 2,500 men and women (including the Marine Corps) who may use the pinochle analogy as a description of their work but consider it anything but a game. Recently, when a group of ACs got together in Memphis, Tenn., to swap professional notes and discuss air traffic control in their areas, their seriousness became apparent.

"Suppose each of these straws represents a runway," the AC said. "Now each of these runways crosses or runs parallel to each other or intersects at right angles and all of them may, at various times, contain aircraft moving from one point to another.

"In the meantime you've got aircraft overhead in the area of this airport. They, too, are flying paths that may cross or run parallel or—God forbid—right at each other.

"If they were all cars on a highway, things could be sorted out and controlled quite nicely. Such things as stop signs and exit ramps, lane markers as well, tell the driver where they may and may not go and when.

"There aren't any stop signs in the air and that's where the air traffic con-

troller comes in," he said.

Air Traffic Control can cover a broad range of feelings according to one Federal Aviation Administration (FAA) man. "On the one hand it can be hours of boredom followed by seconds of sheer terror," he said. "On the other it can be likened to an orchestra conductor smoothly leading his group through a performance."

All ACs learn that their primary mission is to ensure the safe, orderly and expeditious movement of air traffic under varying weather conditions. Contrary to the popular myths revolving around air traffic controllers as the men who sit in glass-enclosed airport towers and—while under a great deal of stress—tell the pilots of planes where to go and when, there's a lot more than meets the eye.

"If all aircraft were the same, the job would be pretty simple," the AC said. "One of our jobs is to maintain separation between planes in the air. But if you've got a single-engine private aircraft putt-putting along at 100 knots, being followed by an A-7 that's cruising at 500 knots, the air controller has to do something about it."

ACs learn, therefore, not only how to direct aircraft, but they also learn details of hundreds of military and civilian aircraft designs and characteristics. "After all, you can't expect a commercial jet to turn in the same radius as that little two-seater."

And it grows even more complicated. When a pilot calls in for land-



signs in the air'



Naval Air Traffic Controlmen (and women) are on duty around the clock and around the world ensuring the safe, expeditious flow of aircraft.

ing instructions, the Air Controlman must give precise and correct instructions. These instructions contain and are based on a great number of determinations made quickly by the AC. First of all, he has to recognize the aircraft and mentally review the performance characteristics associated with this plane. Does it have a fast or slow landing speed? Can it land safely with a cross wind or a tail wind? How much runway does it need to land and under what conditions? Can the plane be safely fitted into the approach pattern?

The AC must make all these determinations in the split seconds dictated by today's high speed aircraft. He doesn't have time to refer the matter to his superior. In the end, having to bear that type of responsibility is what attracts many of the Navy's ACs to their work.

"The best air controllers are not just those who accept responsibility," said one lieutenant commander, a former enlisted AC. "The best are those who actively seek additional responsibility."

Sharing the burden of responsibility within the rate can make for some interesting occurrences. For example, it is not unusual to see a second class petty officer working as an air controlman while a new chief may not be



Left: Air Control students learn proper airport procedures using this mock-up of a typical airport. Above: An air control module is manned during flight operations. Right: Operations onboard USS Incheon (LPH 12).

come home from work and I've known he still 'hasn't landed,' she said. "But there's really no difference between him and anyone else who has a hard day at the office.

"Besides, if they didn't like their work, why is it that every time two air controlmen get together the only thing they talk about is air traffic control?"

Navy ACs are governed by the rules and regulations established by the Federal Aviation Administration (FAA). It is the FAA that grants their "license" to do the job as ACs—the Facility Rating Card. It is also the FAA or a Navy doctor designated by the FAA who conducts annual physical examinations of each air controlman.

The Air Controlman Class "A" School at NATTC, Millington, Memphis, Tenn., is where all fledgling ACs get their first exposure to the maze of equipment, procedures, rules and regulations that dictate the air control-

qualified to do so.

Every time an AC is transferred to a new duty station he must be retrained, requalified and recertified. Every airport has different characteristics. The new AC not only must learn the particular patterns flown in the area but other things as well, like memorizing all objects over 200 feet high in a 20- or 40-mile radius. He must know what type of air traffic to expect and from where. Because of this and many other variables, the newly arrived AC at NAS, Pt. Mugu, Calif., for example, may spend as much as two years learning the layout before being certified.

Then there are the unique requirements placed upon the Navy AC. Aircraft carriers are moving airports. The

AC aboard the carrier must consider that the ship is moving, that his landing field is much smaller than ashore, and that—if it were a combat situation—those planes he is responsible for recovering may not be in the best of shape.

What effect does all this have on the air controlman?

"I know books and movies show us as nervous fellows with ulcers who finally give it all up when the stress gets too great," a master chief AC said. "But that's not the way things are. If we were like that we wouldn't be in the program in the first place."

The master chief's wife was quick to qualify that statement—just a bit. "There have been a few days when he's



man's work. The students train on equipment that closely approximates what they will find in the field. Included in their 14-week training program is time spent on various simulators that can sometimes be scary in their ability to recreate "incidents" that the AC should never have to deal with but be prepared nonetheless.

One very nerve-wracking exercise for the AC student points out the importance of not only knowing what must be done and when but also the limits of one air controller's abilities.

Students sit at their radar panels and guide targets on their screens through the patterns and in the right direction, maintaining safe separation between planes and following the proper procedures. The instructor gradually adds first one, then another target to the radar display. Eventually the student reaches a point where he can no longer safely guide all the simulated aircraft through the patterns and he asks for help.

"The air controller who doesn't ask for help is kidding himself and endangering the planes intrusted to him," one instructor said. "That's why we put these kids through what can be a pretty frustrating exercise."

The story about the air traffic controller who didn't need help also circulates around the school. One AC, with many years experience, guided so many planes during a three-hour period that he did not once "un-key" his microphone during that entire time. His supervisor, who stood by ready to start passing off the overload of planes to another air controller, was flabbergasted. When it was all over, duplicates of the tape made during all conversations between air controller and aircraft were sent to other activities. That Navy AC, and others like him, have earned high praise from the FAA.

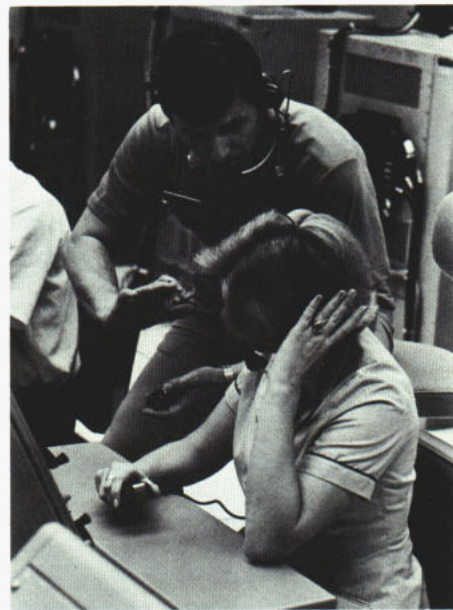

At Air Controlman Class "A" School, individual instruction ensures each student learns the precise procedures required of their demanding rate.



There are about 26,000 FAA civilian air traffic controllers. An instructor at the FAA school for civilian air traffic controllers recently pointed up the reputation of Navy ACs: "Navy Air Controlmen accept a monumental responsibility day in and day out, every hour of the work day. Their ability to do that well is an example all Air Controlmen know and try to emulate."

Anyone for a little double-deck pinochle with an Air Controlman? ♣

AC1 JOE HUEY



Air Traffic Controlman of the Year

Although air controlmen, as a group, don't like to discuss some of the "incidents" that can result in disaster, one that happened last year earned recognition for the air controlman involved and congratulations from his fellow operators.

AC1 Joe D. Huey was named Naval Air Traffic Controller of 1976 because he did his job as he was trained to do it—but in some rather unusual circumstances. You see, Joe was air controller onboard the aircraft carrier *USS John F. Kennedy (CV 67)*, handling 14 planes in the air preparing to land, when that ship and the guided

missile cruiser *USS Belknap (CG 26)* collided.

In *Kennedy's* air traffic control center, he quickly assessed the situation. As the approach controller, Joe immediately notified the 14 pilots of the circumstances and directed them into holding patterns. He gave them altitude assignments and provided constant radar vectors to ensure their safe separation. He did all this while communication equipment damaged in the collision gave out and equipment necessary for the safe landing of aircraft on a carrier became of questionable use.

Huey coordinated the safe landing of all 14 aircraft at a nearby shore installation in spite of equipment problems.

"Petty Officer Huey's calm coordination of the limited communications available and his correct application of emergency air traffic control procedures contributed greatly to the successful recovery of all aircraft," his citation read.

It may have been "all in a day's work" for AC1 Joe D. Huey . . . but what a day! ⚓



U.S. SAVINGS BONDS

Aim for Tomorrow



Alexander Hamilton took quill in hand on Sept. 13, 1789, and signed the first savings bond ever issued by the Treasury of the United States. That bond, for \$20,000, was the first of five such bonds presented to the City of New York for a \$200,000 loan to the federal government. It paid six per cent interest.

Not until 1879, could private citizens invest small amounts of cash in the government. Till then, the U. S. dealt with banks because all bonds had to be paid for in gold coin and there wasn't enough gold in general circulation. Then Congress approved a plan where the little guy could purchase \$10 notes at the window of any post office—this was the birth of the Postal Savings System, which only recently came to an end.

Investment in the government by the private citizen took a big step with Liberty Bond sales in World War I. With World War II came the birth of Payroll Savings and millions of citizens became shareholders with the purchase of Series E and, later, Series H bonds.

Are you one of the shareholders? Now is the time to get on the bandwagon—May is Savings Bond Month. Below are two tables showing how the plan can work wonders for a future retirement or business investment nest egg, or a fund to put junior through college. Keep in mind that the interest rate on new issues of U. S. Savings Bonds is subject to continuous review by the Treasury and may be increased or decreased in accordance with changes in economic and financial conditions. Therefore the below tables reflect *current* interest and growth rates.

HERE'S HOW THE SAVINGS BONDS RETIREMENT PLAN WORKS

Monthly Purchase for 15 years	Original Investment	Interest*	Total Accumulation	Exchange for H Bond	Average H Bond Interest for 10 yrs
\$ 18.75	\$ 3,375	\$ 1,980.36	\$ 5,355.36	\$ 5,500	\$ 27.85
37.50	6,750	3,960.72	10,701.72	11,000	55.70
56.25	10,125	5,941.08	16,066.08	16,500	83.54
75.00	13,500	7,921.44	21,421.44	21,500	108.86
150.00	27,000	15,842.88	42,842.88	43,000	217.72

* Add cash to purchase of next multiple of \$500.

HERE'S HOW YOUR "DOLLARS FOR EDUCATION" GROW IN SERIES E BONDS

If your Child's Age is:	Value of E Bonds at Age 18 through monthly investments of:			
	\$18.75	\$37.50	\$56.25	\$75.00
at birth	\$7,130.47	\$14,260.94	\$21,391.41	\$28,521.88
1	6,503.47	13,006.94	19,510.41	26,013.88
2	5,912.47	11,824.94	17,737.41	23,649.88
4	4,830.21	9,660.42	14,490.63	19,320.84
6	3,868.61	7,737.22	11,605.83	15,474.44
8	3,014.22	6,028.44	9,042.66	12,056.64
10	2,255.16	4,510.32	6,765.48	9,020.64
12	1,580.76	3,161.52	4,742.28	6,323.04

Bearings

The Middies Show Their Colors. . .

June Week at the Naval Academy picked up a new tradition last year when it presented its first naval review.

Last June, the Academy's 80-foot yard patrol craft and 40 sailboats with sails full passed in precision formation before the Naval Academy superintendent and hundreds of June Week visitors.

It will happen again this year. Both the power and sail contingents will have a chance to display their seamanship in two 30-minute demonstrations

of close maneuvers and racing tactics.

The sailing program will feature every type of boat used by the Academy's midshipman sailing squadron, which competes intercollegiately, and the midshipman sailing club.

In addition to sailing races in the Annapolis area, midshipman crews also sail in international trans-ocean races such as the Newport-Bermuda race and the Trans-Atlantic race. Last summer a contingent of Naval Academy yawls sailed with the Tall Ships from Bermuda to Newport.



. . .But Can They Stand Up to the Groton Gang of Four?

One trans-ocean sailing race the midshipmen have entered that may present formidable opposition is this year's Marion (Mass.) to Bermuda race to be held in late June.

The middies will want to keep their eye particularly on a 32-foot ketch crewed by a group who profess, "We don't particularly care about winning the race. We just want to beat the middies."

The four-man Groton crew is composed entirely of Navy chief petty officers—submariners all. "We just want to show those middies that 'Submariners do it better'," said ETC John Williams, owner of the boat *Wanderer* and official spokesman of the Groton crew.

"We're even going to sail her unmanned to give the midshipmen a chance."

Chief Williams admitted this is his first trans-ocean race but professed great confidence in his crew—all of whom have had previous sailing experience. He noted that a "fierce"

training schedule, would get them all in prime shape for the big race.

The other "Wanderer" crewmen—ETCM Mike Quigley, ETC Leroy Osterfeld and QMC Jim Spear (Ret)—count heavily on their common submarine duty and sailing experience. Two of them are also Navy divers.

When asked if this meant they could win the race whether the "Wanderer" was above or beneath the water, Chief Williams chuckled and noted as how he preferred entering Bermuda—ahead of the middies—under full sail and above the water.

Watch future issues of All Hands for the outcome.

What's in a Name?

If you should ever wind up in the hospital at Naval Base, Subic Bay, Republic of the Philippines, you might hear the name Rodriguez more than once. Shown from left, Rolando, Rodolfo and Leonardo Rodriguez, all hospital corpsman, are brothers, stationed at the Subic Bay hospital.



There's only one element missing to make this photograph complete. Camilo, another brother and also a hospital corpsman, is serving with the SeaBees at San Diego, Calif. (Photo by JO1 Jun Calaunan)



Sailor: 1, Robber: 0

When Electronics Technician 2nd Class Kenneth Adkins of the nuclear submarine USS *Shark* (SSN 591) stopped at the Carlisle (Pa.) motel for the night recently he thought he was just going to get a good night's rest before continuing on to Pascagoula, Miss.

What Adkins got instead was a crack on the head and a surprising role in foiling an armed robbery. Here's how the motel manager told the story:

"... Shortly after midnight . . . an armed robber herded six guests and employees from the motel's lobby into the adjoining office, forcing them to hand over their valuables and making the manager open the safe.

"At this point, Kenneth Adkins drove up and came into the motel seeking a room. The robber met him and cracked him over the head with a gun; he then dragged the sailor into the office and started to tie him up.

"At the right moment—and disregarding concern for his own safety—Mr. Adkins kicked the revolver out of

the robber's hand. With another kick, he sent the robber sprawling over a desk. Several people were then able to pin him until the police arrived.

"Mr. Adkins averted still another disaster. One of the guests picked up the revolver and was twirling it around. Had Adkins not retrieved the gun from the woman and kept it, we almost certainly would have had a third shot fired, possibly injuring someone.

"When the police arrived, he tried to forego any hospital treatment for his injuries (fearing it might delay his return to his ship). We insisted, however, and talked him into staying the remainder of the night with us.

"For his actions and assistance, Mr. Adkins has my utmost gratitude and respect. To act as he did, in the face of great danger (the robber was an escaped prisoner) and without regard for his own safety, reaffirms my faith in the men who guard this country's security."

That goes for us, as well!

Twelve Who Marched

NAVYMEN BREAK FOR A REST—Navymen? No, we haven't switched cutlines. Actually, several of these "legionnaires" are Navy personnel assigned to the Naval Communications Station in Sidi Yahia, Morocco. The Navymen, 12 in all, took leave (not French leave, though) to appear as



extras in the movie "March or Die," starring Gene Hackman, Catherine Deneuve and Max Von Sydow. Explained one volunteer, "It's just something I've always wanted to do at one time or another." He didn't indicate whether he was referring to filmmaking or meeting Catherine Deneuve.



Backward Boots

DON'T WORRY FRED, I'VE JUST GOT MY BOOTS ON BACKWARDS—No, the aircrewman reaching through the helicopter hatch is not a contortionist. Photographer's Mate 3rd Class Dan Fort caught the action while onboard USS *Blue Ridge* (LCC 19). Dan sends word the hands belong to one crewman and the feet dangling opposite belong to his assistant. And we thought we had photographic proof of the first rubber aircrewman.

BEST IN THE NAVY

T BY JO1 JERRY ATCHISON

here's a lot that goes into an award-winning Navy club. It's more than a sprig of parsley on your steak.

Personnel of the four clubs recently selected as "Best in the Navy" by the Secretary of the Navy Messes and Club Awards Program know what it takes—and they're happy to share it with every club.

"Listening to patrons and giving them what they want is the operating principle of the Enlisted club at Naval Station, Charleston," said club manager Arthur Bercume. His club was selected as best in the "Enlisted Mess Open" category.

Bercume added that he's not the only one who listens to patrons. "The employees all take pride in the club and their jobs. Their personalities, and the attitude of wanting to please, encourage patrons to voice their suggestions."

Patrons' suggestions at the Charleston club have resulted in things like:

- Specialty food nights each month, with international menus at bargain prices.

- Disc jockeys from local radio stations manning the booth for disco night three nights a week.

- Boxing smoker staged at the club.

- A submarine sandwich and pizza shop open seven days a week when the dining room is closed.

The manager of "The Drydock," another award winning club at the Norfolk Naval Shipyard, thinks his patrons are pretty important also. "We want them to be proud of it," said James P. Astrauckas. His club was selected as best in the "Enlisted Club" category.

"Patrons have a part in improving the facility by evaluating every phase of the service and the items purchased," he said. "We have received some good suggestions, and they are being used in day-to-day operations."

These are some of the things that make "The Drydock" a special club:

- Professional entertainment six nights a week.

- One night of "Quadrascene," an all-encompassing experience with movies, slides, turntable and disc jockey activity.

But award-winning clubs in the Norfolk area are not restricted to "The Drydock." Over at the Naval Amphibious Base, Little Creek, is the winner in the "Chief Petty Officers' Mess Open" category. "The key to success is improvement," said club manager Carl E. Todd.

He went on to say that the reason Little Creek was able to make improvements was due to increased patronage. More customers mean more

money. This, in turn, can be put to work for improvements.

Adding credence to Todd's formula for success is the fact that the Little Creek Chiefs' Club has won the Secretary of the Navy Messes and Clubs Award two out of a possible three times.

Todd, a retired Navy warrant officer with more than 37 years experience in food service, shares common viewpoints with Lieutenant R. B. Read—who has only 18 months' experience in the business.

Read, manager of the Officers' and Faculty Club at the U. S. Naval Academy, reported, "The people working for the Annapolis club are enthusiastic, hardworking employees. Their talent and experience is overwhelming."

Read manages the winner in the "Commissioned Officers' Mess Open" category and is quick to give the credit to his staff. "All the way through the employee ranks, loyalty and enthusiasm reign. The waitresses have all been with the club over five years and one waiter, Mr. Albert Carpenter, has been employed here longer (since 1943) than I've been alive."



Meticulous attention to detail, whether it be in the preparation and presentation of food (left) or in the decor (below) is important to award-winning clubs.



Read brought together many of the successful ideas of the other award-winning club managers. "It doesn't do any good to cut a corner and save a buck if you lose a customer. That leads to an important key: one must offer what his customer wants.

"Sounds simple but it really isn't . . . The club must cater individually to each class of patron because they are equally important for a successful operation."

But "keeping the customer happy" is not the only thing the judges looked at in coming up with this year's four winning clubs. And to those who say they can't offer what these clubs do because of their constrained budgets, take note that each entrant also was graded on sound fiscal controls and effective management.

It boils down to professional service, heeding the customers' advice and creative investments in popular activities.

—And that's more than a sprig of parsley on the steak.

(See page 42)



Well-trained, conscientious employees make sure customers of an award-winning club get exactly what they ordered.



Patrons of the Commissioned Officer's Mess (Open), Naval Academy, Annapolis, enjoy a buffet, at their award-winning club.



The spacious "Drydock" Enlisted Mess (Open) at Naval Shipyard Norfolk, another award winner.

Nepal Pilgrims

From Kathmandu to Everest

PHOTOS BY LT HELENIAK AND
LT M. S. HARDER, III

“. . . request the pleasure of your company on trek in Nepal,” read the unexpected telegram last September to Lieutenant J. F. Heleniak, a Supply Corps officer stationed in West Palm Beach, Fla. Its author was a fellow Supply type, Lieutenant M. S. Harder, III, assigned halfway around the world in Hong Kong. Two months, four telegrams and many letters later, Heleniak and Harder converged on the land of Everest to begin what may have been the most unusual leave undertaken by Navy personnel in 1976. Here is LT Heleniak’s account.

After two months of detailed preparations, the 30-hour jet ride halfway around the world gave me time in which to mull over my proposed leave.

“Nepal? Where the . . . is that?” the postman had asked when he delivered my passport. Then, I tried to get information by telephone about Kathmandu, the operator asked, “Oh, is that in Canada?” Even my father, when told of my planned vacation to Nepal, said jokingly, “. . . something’s snapped in that brain of yours.”

I imagined Nepal as an exotic, remote mountain sanctuary, inhabited by mysterious mountain people and the

*Mount Everest, grandfather of mountains,
seen from the air during a sightseeing flight.*



Below: Porters are paid \$1.50 a day to carry loads of about 80 pounds, 10 to 15 miles. Right: Temples of Kathmandu.

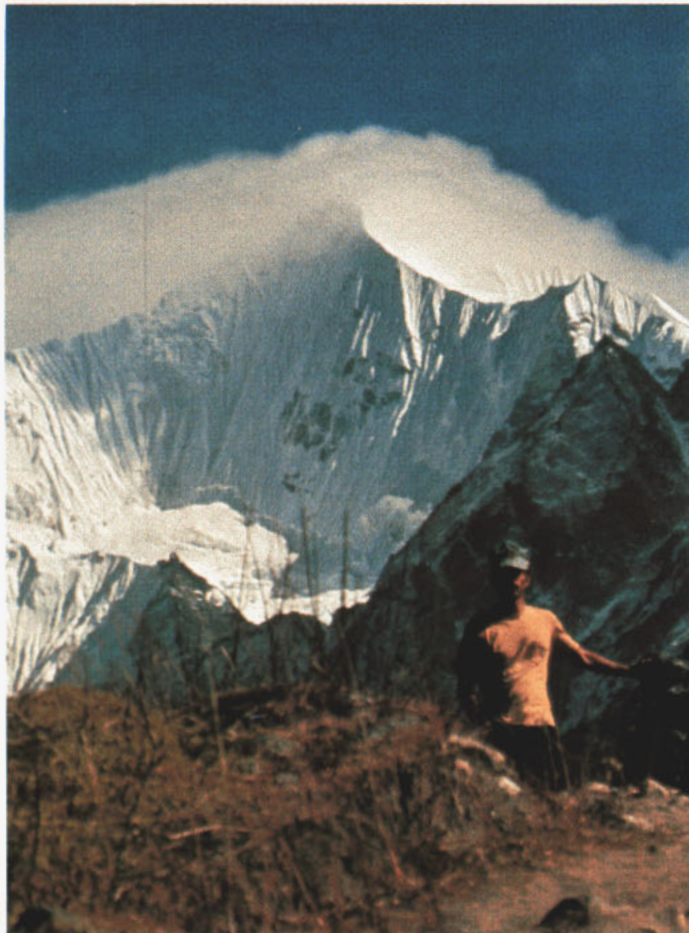
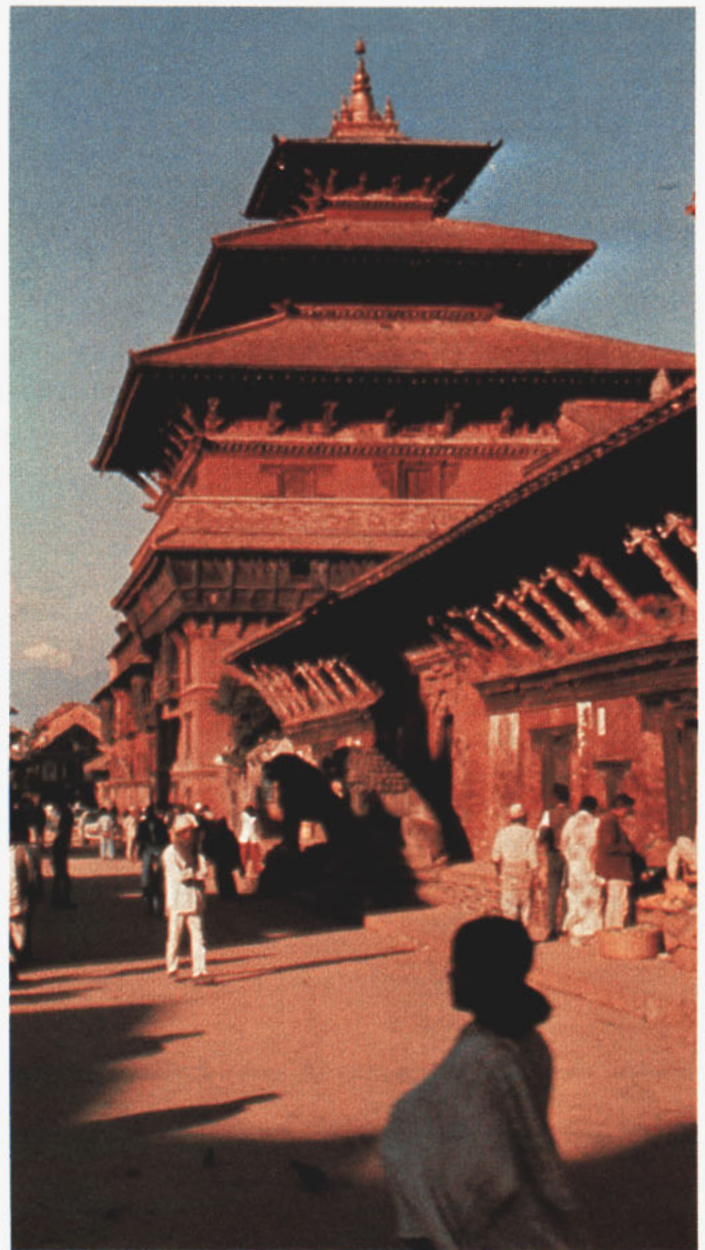

Left: Jim Heleniak, one of the expedition participants, is seen near 23,000-foot Lonpo Gang mountain. Above: The high elevations don't bother a yak grazing on scrub grass at the 10,500-foot level.

whole area overshadowed by the tallest of them all, Mt. Everest.

Before beginning our trip into the mountains, we spent three days acclimatizing to Kathmandu's moderate 4,300-foot elevation. We also learned that it never snows in Kathmandu (located on the same latitude as Miami, Fla.). But summer months bring monsoon rains from India's Bay of Bengal creating miserable leech-ridden, hiking conditions. The winter months of late December and January are quite cold and windy with heavy snowfalls in the higher valleys.

While not too well known in the United States, "trekking"—the British term for hiking—is popular in Nepal where you can hire bearers or porters for \$1.50 a day to carry all your equipment. Our group of 10 trekkers started out with 29 porters and seven Sherpa guides.

Because the Sherpas spend most of their lives at altitudes varying from 7,000 to 14,000 feet, they are incredibly strong at high altitudes. Our Sherpa leader, Mr. Ang Lima, 28, had been on some full-scale Himalayan expeditions and had climbed as high as 26,000 feet without the aid of supplemental oxygen.

Throughout the trek, Sherpas supervised the porters, prepared the food and generally took care of everything. Sherpas are extremely loyal to the trekker. Even if a trekker sprains an ankle or cannot walk, they will take turns carrying the disabled hiker on their backs. One of the leader's unpleasant duties was to dismiss unnecessary porters as our supplies diminished. Our original group of 29 porters was reduced to 19 by the last day of the trek.

Each porter, incredibly strong, carries loads weighing up to 100 pounds, balanced on his back with a support strap around his forehead.

During a typical day of trekking to Langtang Valley we passed through two villages and across many farmfields terraced into the steep hillside. Trekkers are regarded by the villagers as rich people from faraway lands and they were fascinated by our dress and fancy equipment. Every night we had an audience of children who watched the activities in our camp until sundown.

We had one strenuous day which featured a very steep climb from 8,400 feet to 13,500 feet over a distance of about seven miles. The other days averaged 11 miles over roughly 3,000 feet in elevation gains and losses.

After our trek to Langtang valley—with its majestic mountains—we returned to Kathmandu via an area of lakes called Gosain Kund—an area of major religious importance to Hindu worshippers, because the third lake is considered a Hindu holy lake.

Aside from a few headaches, nobody in our group suffered any ill effects from the thin air. (If you're planning such a trek, you should have a thorough physical exam before any high altitude climbing and also set a vigorous physical conditioning program to build up to top trim.)

All in all, rural Nepal and Kathmandu provide vacations for the adventurous. The friendly, cooperative people, the curious mountain villagers, the spectacular Himalayas, the intricate temples of the Kathmandu valley and the sense of accomplishing a truly unique adventure, all combined to make Nepal one of the best vacation spots in Asia.

Anyone for trekking? ⚓

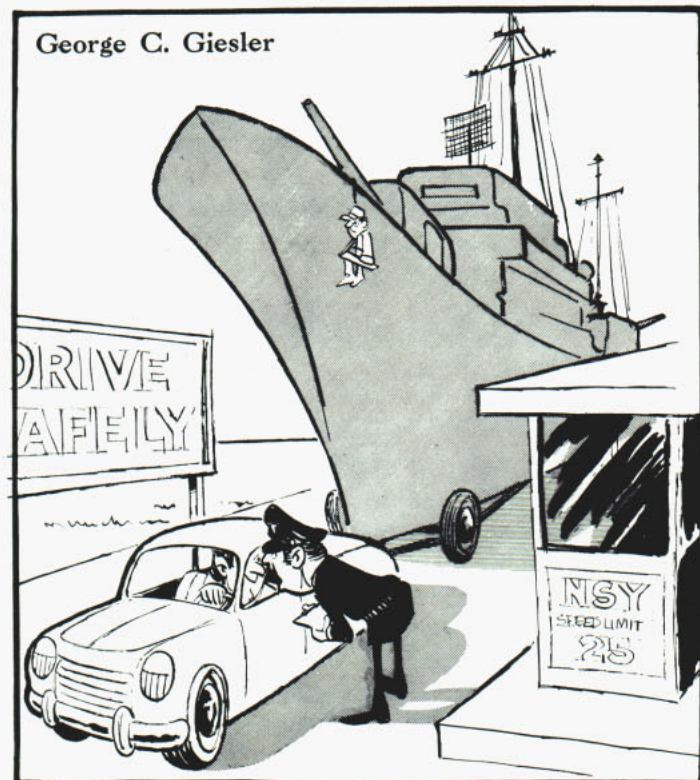

"I'd like to check your trunk, please!"

NAVY RELIEF

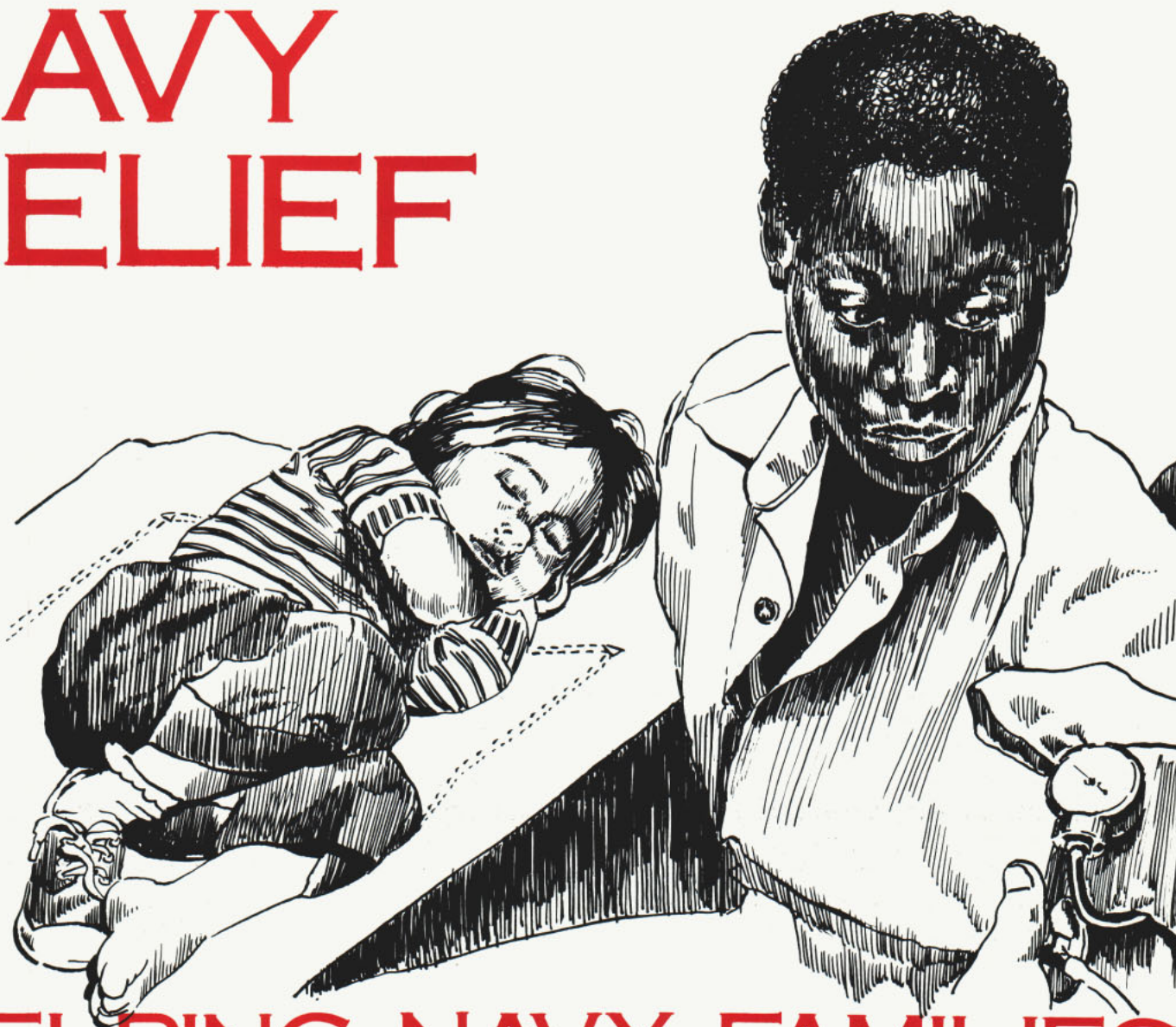

HELPING NAVY FAMILIES

When Hurricane *Pamela* hit the Island of Guam, Navy Relief officials responded to the request of Commander, U.S. Naval Forces, Marianas, for assistance and wired \$100,000 to be used in relief efforts.

A phone call to Navy Relief Headquarters from a senior commander in the European area advised that 75 Naval personnel had not received their pay checks because of a mix-up. Although it had been confirmed that the checks were in the mail, there was growing concern for the payment of bills and necessary household expenses. Navy Relief came forward with the offer of immediate financial assistance.

These are two examples of unusual situations in which help was ren-

dered by Navy Relief last year. But there were thousands of individual family emergency situations in which the Navy Relief Society provided \$5.3 million to those in need. In helping more than 75,000 individuals and families, the organization dispersed:

- \$3.5 million in direct relief loans
- \$1.3 million in education loans and
- \$471,000 in gratuities.

While dispensing funds is Navy Relief's chief occupation, the Society would be unable to do so without the donations of Navy people. Last year, Navy men and women contributed more than \$2.3 million to their relief

agency. This year, the call for donations is going out again.

During the period May 6 to June 6, Navy personnel will be called upon to help support their own charitable organization. But whether it is a Navy charity or any charity, it is important to know, first, exactly how those funds are used and what services the Navy Relief can provide.

Navy Relief offers emergency assistance for Navy and Marine Corps active duty and retired personnel, their dependents and their surviving widows and children. There is no field of human trouble in which the Society has not helped, either through counseling or by necessary financial assistance.

The types of aid provided include:



IN NEED

- *Financial Assistance*—may be an outright grant, a loan without interest, or a combination of the two, depending on the circumstances in each case and the degree of hardship that may be involved in the repayment of the loan.

- *Layettes*—made by volunteers for new babies, for those who need them.

- *Thrift Shops*—where articles of clothing and essentials may be purchased at rock-bottom prices.

- *Children's Waiting Rooms*—provided at naval medical facilities.

- *Counseling*—on financial management and referrals to community resources with special attention to the young Navy person and service family.

- *Visiting Nurses*—who visit mothers and their newborn infants, and the

elderly in need of medical attention at home.

- *Educational Programs*—providing opportunities for higher education to dependent children who might otherwise be unable to pursue their education beyond the high school level.

- *Sponsor Outside Programs*—such as Live Better for Less, Helping Hands, Toys for Tots, Motor Corps, and similar activities.

Those are a lot of services for the money. But there is one more important point to be made about the money Navy Relief collects each year: Not one penny of this collected money goes to pay salaries of Navy Relief personnel or telephone bills. Contributions go directly to help sailors and

Marines and their families in need. Funds to cover overhead comes from interest earned on investments made by Navy Relief many years ago.

In those areas with no Navy Relief activity nearby, the American Red Cross serves as the contact point and your commanding officer ashore or afloat can get Navy Relief support for you. So you're never far from help.

The idea behind Navy Relief hasn't changed since the Society was founded more than 70 years ago . . . "the Navy and Marine Corps take care of their own."

You can carry on this proud tradition by supporting your Navy Relief Society so that it will be here to help you tomorrow. ⚓

BENEFITS DON'T MEAN A THING UNTIL YOU'RE WITHOUT THEM.



Quality medical care for you and your family is just one of your Navy benefits. Price it out in civilian life and you know it doesn't come cheap.

In fact, you probably know your benefits by heart now. Because you count on them. Things like commissary and exchange privileges. 30 days' annual paid vacation. Housing. Retirement. Just to name a few.

But what good are benefits without job satisfaction? The question is, do you know all about the many career

opportunities currently available to you in the Navy.

Did you know that reenlistments under the STAR, SCORE or GUARD II Programs can open many new doors? With more training. New assignments. And a chance to run your own shop.

Or that there's plenty of room for growth in your present job? With an opportunity to earn an extra stripe or two. More responsibility. More schooling. Maybe even a reenlist-

ment bonus, too.

In your next hitch, you'll find advancement coming a lot quicker than if you had to start all over again in a civilian job.

The opportunities, and the benefits that go with them, are there. If you're ready to accept the challenge. So get the full story. See your Command Career Counselor soon. You won't get any sea stories.

You'll get the facts.

NAVY

IF YOU'RE GOOD, IT PAYS TO STAY IN.

Stern Shots

Don't be gun shy. How many of the missiles pictured here can you name? Check your answers at the bottom of this page.

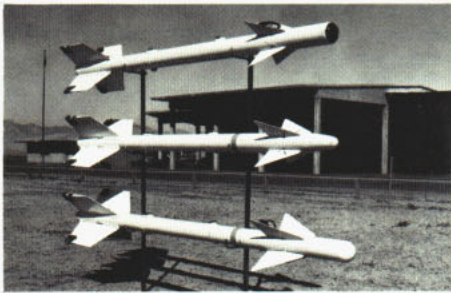

A

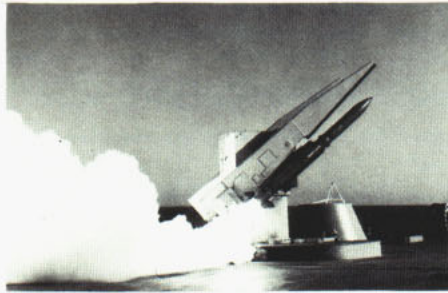

B



C

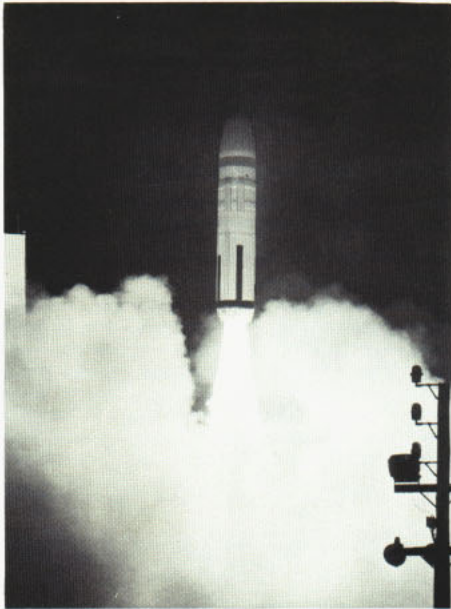

D



E



F

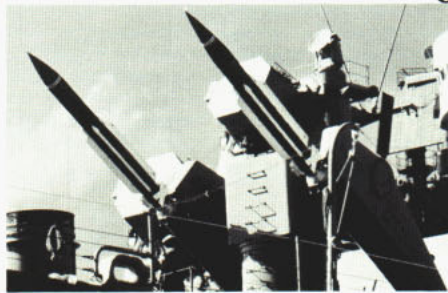

G



H

All Hands, the magazine of the U.S. Navy, published for the information and interest of all members of the Naval service, is issued monthly by the Office of the Chief of Information, Room 2E329, Pentagon, Wash., D.C. 20350. Issuance of this publication is approved in accordance with Department of the Navy Publications and Printing Regulations, P-35 (revised January 1974). Opinions expressed are not necessarily those of the Department of the Navy. Reference to regulations, orders and directives is for information only and does not by publication herein constitute authority for action. All original material may be reprinted.

ORIGINAL ARTICLES and information of general interest may be forwarded addressed to the Editor, All Hands, Navy Internal Relations Activity, Print Media Division, Room 1044, Crystal Plaza No. 6, 2221 Jefferson Davis Highway, Wash., D.C. 20360.

DISTRIBUTION: All Hands is distributed to all Navy activities on the standard Navy Distribution List (SNDL) on the basis of one copy for approximately six naval officers and enlisted personnel on active duty. Limited distribution to Marine Corps activities is effected by the Commandant.

PERSONAL COPIES: The Magazine is for sale by Superintendent of Documents, U.S. Government Printing Office, Wash., D.C. 20402. The rate for All Hands is \$1.65 per copy; subscription price is \$19.00 a year, domestic (including FPO and APO address for overseas mail); \$23.75 foreign. Remittances should be made payable to the Superintendent of Documents and forwarded directly to the Government Printing Office.

Answers: A(Sidewinder), B(SM-1 fired from Aegis platform), C(Harpoon), D(Trident), E(Talos), F(Tartar), G(Terrier), H(Phoenix).

In this issue:

The Soviet Challenge

