

Audit



Report

OFFICE OF THE INSPECTOR GENERAL

REVIEW OF THE V-22 AIRCRAFT PROGRAM

Report No. 94-131

June 14, 1994

Department of Defense

Additional Copies

To obtain additional copies of this report, contact the Secondary Reports Distribution Unit, Audit Planning and Technical Support Directorate, at (703) 614-6303 (DSN 224-6303) or FAX (703) 614-8542.

Suggestions for Future Audits

To suggest ideas for or to request future audits, contact the Planning and Coordination Branch, Audit Planning and Technical Support Directorate, at (703) 614-1868 (DSN 224-1868) or FAX (703) 614-8542. Ideas and requests can also be mailed to:

Inspector General, Department of Defense
OAIG-AUD (ATTN: APTS Audit Suggestions)
400 Army Navy Drive (Room 801)
Arlington, Virginia 22202-2884

DoD Hotline

To report fraud, waste, or abuse, call the DoD Hotline at (800) 424-9098 (DSN 223-5080) or write to the DoD Hotline, The Pentagon, Washington, D.C. 20301-1900. The identity of writers and callers is fully protected.

Acronyms

ASN(RD&A)	Assistant Secretary of the Navy (Research, Development, and Acquisition)
CSC	Conventional Systems Committee
DAB	Defense Acquisition Board
DAE	Defense Acquisition Executive
EMD	Engineering and Manufacturing Development
FSD	Full-Scale Development
FSED	Full-Scale Engineering Development
JROC	Joint Requirements Oversight Council
JSOR	Joint Services Operational Requirement
MLR	Medium-Lift Replacement
MV-X	Special Operations Advanced Multi-Mission Vertical Lift Aircraft
NAVAIR	Naval Air Systems Command
ORD	Operational Requirements Document
SECNAV	Secretary of the Navy
USD(A)	Under Secretary of Defense for Acquisition
USD(A&T)	Under Secretary of Defense for Acquisition and Technology



INSPECTOR GENERAL
DEPARTMENT OF DEFENSE
400 ARMY NAVY DRIVE
ARLINGTON, VIRGINIA 22202

June 14, 1994

**MEMORANDUM FOR ASSISTANT SECRETARY OF THE NAVY (RESEARCH,
DEVELOPMENT, AND ACQUISITION)**

SUBJECT: Review of the V-22 Aircraft Program (Report No. 94-131)

We are providing this final report for your information and use. The report discusses our review of the Navy V-22 Aircraft Program as a part of our Audit Project No. 3AE-0063, "Effectiveness of the Defense Acquisition Board Review Process for Fiscal Year 1994."

Your May 2, 1994, comments on a draft of this report provided an acceptable alternative solution to our recommendation. Therefore, no additional comments are required.

We appreciate the courtesies extended to the audit staff. If you have any questions on this report, please contact Mr. Brian M. Flynn, Acting Program Director, at (703) 693-0186 (DSN 223-0186) or Mr. Dennis E. Coldren, Project Manager, at (703) 693-0400 (DSN 223-0400). The distribution of this report is listed in Appendix D. The audit team members are listed inside the back cover.

A handwritten signature in black ink, reading "Robert J. Lieberman", is positioned above the typed name.

Robert J. Lieberman
Assistant Inspector General
for Auditing

Office of the Inspector General, DoD

Report No. 94-131
(Project No. 3AE-0063.01)

June 14, 1994

REVIEW OF THE V-22 AIRCRAFT PROGRAM

EXECUTIVE SUMMARY

Introduction. The Navy V-22 Osprey is a tilt-rotor, vertical takeoff and landing aircraft being developed for Joint Service application. The aircraft (Appendix A) is being designed to meet the amphibious and vertical assault needs of the Marine Corps, strike rescue needs of the Navy, and long-range needs of the U.S. Special Operations Command. The V-22 is an alternative to replace selected helicopters in the Navy and Marine Corps and to supplement existing Special Operations Command helicopters and aircraft. In May 1986, the V-22 Program entered Full-Scale Development. In April 1989, the Secretary of Defense deleted all funding after FY 1989 for the V-22 Program. However, Congress continued to fund the V-22 Program and mandated further development. In October 1992, the Navy terminated the Full-Scale Development contract and awarded an Engineering and Manufacturing Development (EMD) letter contract for \$550 million. Appendix B contains a chronology of events for the V-22 Program.

Objectives. The overall audit objective was to evaluate the Defense Acquisition Board (DAB) review process for the V-22 Program. Specifically, we assessed DAB oversight of the V-22 Program from April 1989 through March 1994 and adequacy of documentation prepared for the DAB Milestone II-Plus review originally scheduled for November 1993. We also assessed applicable internal controls.

Audit Results. The DAB review process was not properly utilized and therefore has not been effective for the V-22 Program. The V-22 Program entered EMD without proper authorization, a DAB review, a validated requirement, or a valid acquisition program baseline. Also, the Navy made major program decisions without either formal review by the Office of the Secretary of Defense or documented approval by the Defense acquisition executive (DAE). Although the time allowed to prepare for the Milestone II-Plus DAB review was limited, documentation required by the DAE for the review was reasonable and the review had the potential to correct deficiencies noted in this report, including a lack of current program documentation. On December 8, 1993, the DAE postponed the Milestone II-Plus review scheduled for the next day and later rescheduled it for September 1994.

Internal Controls. The audit did not identify material internal control weaknesses. Existing internal controls, if properly implemented, were sufficient to correct the deficiencies noted in this report. However, we found noncompliance with existing controls in the acquisition process. Part I of the report discusses the internal controls assessed.

Potential Benefits of Audit. Potential benefits of this audit were realized through implementation of alternative action to the draft report recommendation. In the

alternative action, the Navy acquisition executive obtained the approval of the DAE and concurrence of the Vice Chairman, Joint Chiefs of Staff, to definitize the EMD contract and increase DoD's financial commitment to the V-22 Program.

Management Comments. In our draft audit report, we recommended that the Assistant Secretary of the Navy (Research, Development, and Acquisition) postpone definitization of the V-22 EMD contract and limit obligation of contract funding to no more than the FY 1993 and prior appropriations until the DAB Milestone II-Plus review was held and the DAE chose the V-22 as the alternative to meet validated requirements. The Assistant Secretary did not concur with the draft recommendation. However, the Assistant Secretary proposed alternative corrective actions that included obtaining DAE approval to definitize the contract; soliciting concurrence of the Vice Chairman, Joint Chiefs of Staff, with definitization; and ensuring the Government's financial commitment was appropriately limited. The Navy definitized the contract, with the approval of the DAE, as a cost-plus-award-fee contract on May 3, 1994. A full discussion of the Assistant Secretary's response is in Part II and the complete text of the comments is in Part IV.

Audit Response. The alternative corrective actions met the intent of our draft audit report recommendation. However, we remain concerned that further delays in the DAB Milestone II-Plus review will again result in significant increases in Government liability unless a DAE decision is made on the production program. Therefore, we plan to follow-up on management actions to conduct the DAB review on schedule and appropriately limit DoD obligations until a decision is made.

Table of Contents

Executive Summary	i
Part I - Introduction	
Background	2
Objective	3
Scope and Methodology	3
Internal Controls	3
Prior Audits and Other Reviews	4
Part II - Finding and Recommendation	
Utilization of the Defense Acquisition Board Review Process	6
Part III - Additional Information	
Appendix A. Drawings of a V-22	30
Appendix B. Chronology of Events for V-22 Program	31
Appendix C. Organizations Visited or Contacted	39
Appendix D. Report Distribution	40
Part IV - Management Comments	
Assistant Secretary of the Navy (Research, Development, and Acquisition) Comments	44

This report was prepared by the Acquisition Management Directorate, Office of the Assistant Inspector General for Auditing, Department of Defense.

Part I - Introduction

Introduction

Background

The Navy V-22 Osprey (Appendix A) is a tilt-rotor, vertical takeoff and landing aircraft being developed for Joint Service application. The aircraft is being designed to meet the amphibious and vertical assault needs of the Marine Corps, strike rescue needs of the Navy, and long-range needs of the U.S. Special Operations Command (Special Operations Command). The V-22 is an alternative being considered to replace selected helicopters (CH-46E and CH-53D) in the Navy and Marine Corps and to supplement existing Special Operations Command helicopters and aircraft.

In April 1986, the V-22 Program passed Milestone II and entered Phase II, Full-Scale Development (FSD). In May 1986, the Navy awarded a fixed-price-incentive FSD contract with a ceiling price of \$1,825 million to the team of Bell Helicopter Textron, Inc., and Boeing Helicopter Company (Bell-Boeing) to design and produce six aircraft for flight and ground testing. Five of the six aircraft were produced but two crashed and were destroyed.¹ The FSD contract also included an option to buy 12 aircraft under pilot production. Also in May 1986, the Navy awarded a firm-fixed-price contract with a ceiling price of \$76 million to Allison Gas Turbine (Allison) to develop and produce engines for the FSD aircraft.

In April 1989, citing lack of affordability, the Secretary of Defense deleted all funding after FY 1989 for the V-22 Program and requested funding for a mix of CH-53 and H-60 helicopters. However, Congress denied the Secretary's request and continued to fund the V-22 Program. In June 1991, in response to a congressional mandate to obligate \$200 million, the Navy awarded Bell-Boeing an FSD Phase II letter contract for \$75 million, which was definitized in May 1992 as a cost-plus-fixed-fee contract and, as of March 1994, had a target price of \$109 million. In July 1992, in an effort to resolve the continuing impasse between DoD and Congress, the Secretary of Defense proposed a solution to congressional leaders that involved developing and evaluating the V-22 and helicopters as alternatives to the medium-lift replacement (MLR) requirement.

In October 1992, the Navy terminated the FSD contract and awarded a cost-reimbursable Engineering and Manufacturing Development (EMD) airframe letter contract to Bell-Boeing for \$550 million (\$558 million as of March 1994). In December 1992, the Navy awarded an EMD engine letter contract to Allison for \$65 million, which was definitized in September 1993 as a cost-plus-incentive-fee contract with a target price of \$141 million. In May 1994, the Navy definitized the EMD letter contract as a cost-plus-award-fee contract for \$2.65 billion. Appendix B expands on the chronology of events for the V-22 Program.

¹Aircraft #5 crashed during its first flight (before delivery to the Government) on June 11, 1991, and aircraft #4 crashed on July 20, 1992.

Objective

The overall audit objective was to evaluate the Defense Acquisition Board (DAB) review process for the V-22 Program. Specifically, we assessed DAB oversight of the V-22 Program from April 1989 through March 1994 and adequacy of documentation required for the DAB Milestone II-Plus review scheduled for December 9, 1993. Further, we assessed compliance with DoD Directive 5000.1, "Defense Acquisition," February 23, 1991; DoD Instruction 5000.2, "Defense Acquisition Management Policies and Procedures," February 23, 1991; and DoD Manual 5000.2-M, "Defense Acquisition Management Documentation and Reports," February 23, 1991. We also reviewed applicable internal controls.

Scope and Methodology

We performed this program audit from August 1993 through March 1994 and reviewed records dated May 1986 through February 1994 related to the V-22 Program. We performed this audit in accordance with auditing standards issued by the Comptroller General of the United States, as implemented by the Inspector General, DoD, and accordingly included such tests of internal controls as were deemed necessary. We reviewed DAB documentation, acquisition plans, contractor proposals, and contracts related to the V-22 Program. We discussed issues related to the V-22 Program, DAB review process, and preparation or review of DAB-required documents with officials and personnel from the Office of the Secretary of Defense, the Joint Staff, the Navy, the Marine Corps, and the Defense Logistics Agency. The audit did not place material reliance on the evaluation of computer-processed data to support the finding and recommendation. Appendix C lists organizations visited or contacted.

Internal Controls

We assessed internal controls related to the V-22 Program management and implementation of the requirements in DoD Directive 5010.38, "Internal Management Control Program," April 14, 1987, including performance of vulnerability assessments and management control reviews. Those controls and procedures are specified in DoD Directive 5000.1 and DoD Instruction 5000.2. The audit did not identify material internal control weaknesses; however, we found widespread noncompliance with existing controls in the acquisition process. Existing internal controls, if implemented, were adequate to prevent or detect the deficiencies noted in this report. Copies of the final report will be provided to the senior officials responsible for internal controls within the Office of the Secretary of Defense and the Department of the Navy.

Introduction

Prior Audits and Other Reviews

During the last 5 years, no audits covered the V-22 Program primarily relating to the DAB review process.

Part II - Finding and Recommendation

Utilization of the Defense Acquisition Board Review Process

The DAB review process was not properly utilized and has not been effective for the V-22 Program. Through award of a letter contract, the Program entered Engineering and Manufacturing Development (EMD) without proper authorization, a DAB review, a validated requirement, or a valid acquisition program baseline. Further, after 20 months in EMD, the Program still does not have a validated requirement or valid baseline and the DAB has not decided whether the V-22 will meet future medium-lift needs of the armed forces. While we recognize that the V-22 Program has encountered highly unusual political factors over the past 5 years, the main cause of the conditions noted in this report was the abandonment of numerous fundamental elements of the acquisition process. As a result, the V-22 Program's lack of necessary direction has added to continued Program uncertainty. Lacking a decision on the Program, the EMD contract remained undefinitized for 19 months and the Government liability continued to escalate. Although the DAB review that will determine whether the V-22 Program should continue has been postponed until September 1994, the Navy, in response to a draft of this report, obtained approval of the Under Secretary of Defense for Acquisition and Technology (USD[A&T]) to definitize the \$2.65-billion EMD contract in May 1994. However, we remain concerned that further delays in the DAB review could permit the Government financial obligation to increase significantly, particularly regarding prospective FY 1995 funding, without a DAB decision to produce the V-22.

Background

The V-22 Program is an Acquisition Category ID program, a major Defense acquisition program (major program) for which the USD(A&T)² is the milestone decision authority. The USD(A&T) chairs the DAB for milestone reviews; the DAB is supported by three committees. The committee responsible for oversight of the V-22 Program is the Conventional Systems Committee (CSC), chaired by the Director, Tactical Systems, Office of the USD(A&T). Requests for exceptions or waivers to any mandatory provisions of DoD Instruction 5000.2 must be submitted to the USD(A&T) via the DoD Component acquisition executive unless the Instruction grants specific waiver authority below the Under Secretary level. Statutory requirements may not be waived.

²Before November 1993, USD(A&T) was the Under Secretary of Defense for Acquisition (USD[A]).

Entry Into Engineering and Manufacturing Development

The V-22 Program's entry into EMD was irregular in four key ways:

- o no proper authorization was documented entering EMD,
- o no adherence to the acquisition chain was maintained entering EMD,
- o no DAB review was held before entering EMD, and
- o no validated requirement or valid acquisition program baseline has existed since the V-22 Program entered EMD.

Authorization to Enter Engineering and Manufacturing Development. A proper authority did not document authorization to enter EMD. Proper authorization would include an acquisition decision memorandum or a "Justification and Approval for Other Than Full and Open Competition." An acquisition decision memorandum signed by the DAE would be used to authorize entry into the EMD phase of the acquisition process and a Justification and Approval signed by the Service acquisition executive would be used to authorize award of contracts of more than \$50 million. Neither approval existed when the EMD contract was awarded in October 1992. The highest level of documented direction for EMD was made by the Program executive officer in a memorandum, dated October 19, 1992, which stated:

AIR-215J is authorized to proceed with contract award for the procurement of the V-22 EMD effort to include modification of two existing aircraft, 4 new production representative aircraft and a full flight test program to include OPEVAL [operational evaluation]. Concurrent with the above action, because the effort under the FSD contract has become superfluous to changing requirements, you are authorized to modify the existing FSD contract to delete all remaining work from CLINs [contract line item numbers] 0001 through 0027 and obtain consideration for the effort not completed.

This direction represented a major expansion in the scope of effort for which the request for proposal was issued and contract proposal was received. Both the request for proposal and proposal called for a V-22 Derivative Demonstration Program and limited the total funding to funds already appropriated for FY 1992 (\$790 million) plus any earmarked for FY 1993 (ultimately \$755 million). This scope and funding was consistent with the Secretary of Defense's proposal; the Justification and Approval approved by the Assistant Secretary of the Navy (Research, Development, and Acquisition) (ASN[RD&A]); the V-22 Acquisition Plan, dated August 17, 1992; and the FY 1993 Authorization Act.

No subsequent request for proposal was issued for the EMD effort; however, the contract issued October 22, 1992, contained a statement of work for EMD that included design, fabrication, and flight testing of four production-representative aircraft. Also, a revised acquisition plan was approved October 29, 1992. This plan:

Utilization of the Defense Acquisition Board Review Process

- o changed the procurement from a "V-22 derivative design and an advanced technology operational demonstration" to a V-22 EMD Derivative Program,

- o increased funding to include funds made available in FYs 1994 through 1999 in addition to FYs 1992 and 1993 appropriated funds, and

- o added an upgraded engine to the program.

Although the EMD letter contract had a \$550-million price, the Navy's estimate to complete the EMD program was \$2,276 million.

In a February 24, 1993, memorandum addressed to the Assistant Secretary of the Navy (Research, Development, and Acquisition),³ the Program executive officer stated:

In October 1992, based on verbal direction from the Secretary of the Navy, we awarded a letter contract to the team of Boeing Helicopter Company and Bell Helicopter Textron for engineering and manufacturing development (EMD) of the V-22 aircraft. The contract was awarded without the benefit of an approved Acquisition Program Baseline Agreement or documented approval to enter EMD. . . . I strongly recommend that a Defense Acquisition Board program review be scheduled as soon as possible to formally document approval to enter EMD and provide definitive guidance concerning operational requirements and production planning.

We interviewed the Program executive officer about authorization to enter EMD. In response, he stated that after a series of briefings on the V-22 proposal were given to the Acting Secretary of the Navy (SECNAV) and congressional leaders, the former ASN(RD&A) directed him to terminate the FSD contract and award the EMD airframe and engine letter contracts. We also interviewed the former ASN(RD&A). He stated that, based on the documentation, he must have authorized EMD but he did not specifically recall the decision.

Adherence to the Acquisition Chain. Former senior Defense officials did not adhere to the acquisition chain for the V-22 Program in that the former USD(A) did not take an active role as DAE and the Acting SECNAV apparently issued programmatic direction outside his authority. Title 10, United States Code, section 133, states:

Subject to the authority, direction, and control of the Secretary of Defense, the Under Secretary of Defense for Acquisition shall perform such duties and exercise such powers in relation to acquisition as the Secretary of Defense may prescribe, including supervising Department of Defense acquisition.

³From January 20, 1993, until October 22, 1993, the position of ASN(RD&A) was filled on an interim basis.

Utilization of the Defense Acquisition Board Review Process

DoD Directive 5000.1 states that program direction and control must be issued by and flow through a streamlined chain of authority and accountability. Since the V-22 Program is an Acquisition Category ID program with the USD(A&T) as the milestone decision authority, the chain of authority and accountability flows from the USD(A&T) to the ASN(RD&A), Program executive officer, and Program manager, respectively.

Actions by the Former Secretary of Defense. Only one document indicated the intent of the former Secretary of Defense regarding a new V-22 Program. On July 2, 1992, the Secretary wrote a letter to the majority and minority leaders of the Senate and House of Representatives "to resolve the current impasse over the expenditure of fiscal year 1992 funds for the V-22 tilt-rotor aircraft." The Secretary's proposal had two main points:

- o FY 1992 funds would be merged with FY 1993 funds for advanced technology and operational demonstrations for the V-22 aircraft and a new medium-lift helicopter.

- o The Administration would promptly pursue the demonstrations but defer a final decision on which alternative would best meet the future medium-lift needs of the armed forces. The proposal included modification of the two remaining FSD aircraft,⁴ deferral of the number of new aircraft to be built pending results of contract negotiations, and demonstration of operational usefulness for medium-lift needs.

Actions by the Former Under Secretary of Defense for Acquisition. In April 1991, the USD(A) established policy on contract review procedures for major programs. The policy stated:

I intend to review RFPs [requests for proposals] and contracts for selected major Defense acquisition programs prior to their release or execution. . . . Please notify me at least 30 days in advance of your intention to issue an RFP, announce the offeror selected, or award a contract for the . . . engineering and manufacturing development . . . phases of a major Defense acquisition program. In order to ensure that any necessary changes resulting from my review can still be made with minimum disruption, you may not release the RFP, award, or announce the winner of a contract until the completion of my review.

However, the USD(A) declined to review the V-22 EMD airframe and engine requests for proposal and contracts. In a memorandum to the ASN(RD&A) concerning the "V-22 Derivative Demonstration Program," October 20, 1992, the Deputy USD(A) stated, "I have chosen not to review the V-22 contract. It may be awarded upon completion of the Navy review." Further, the USD(A) did not conduct a DAB program review for EMD and did not formally authorize, approve, or provide guidance for the EMD decision.

Actions by the Former Acting Secretary of the Navy. On July 28, 1992, the Acting SECNAV directed release of the request for proposal to Bell-

⁴Aircraft #2 and #3 remained for flight testing as #1 was planned for ground testing, #4 and #5 crashed, and #6 was never completed.

Utilization of the Defense Acquisition Board Review Process

Boeing for a V-22 derivative advanced technology operational demonstration. On August 5, 1992, he testified before the House Armed Services Committee on the V-22 Program. The purpose of the hearing was to determine whether and how the DoD was planning to implement congressional direction to continue development of the V-22 aircraft. During the hearing, the Acting SECNAV said:

o In response to a question as to whether the contract would emphasize demonstration and validation or EMD, DoD was looking for a Full-Scale Engineering Development (FSED)⁵ follow-on, a FSD II cost-plus contract. He stated, "If you want to call it a demonstrator, a prototype, we are not making a production decision at this time." He added that DoD intended to do an FSED follow-on but to stop short of production because there was

nothing that the Congress has done thus far to make a production decision. . . . Whatever, semantically, you want to call it, we are hoping to get more aircraft that can be tested and validated to meet whatever demands are produced by that, as well as to proceed and make a production decision as to what we elect to finally go with.

o Regarding award of a contract, a DAB meeting would have to be held later the following month (September 1992) to approve the program and send out the request for proposal.

o In response to one member who recalled a meeting where the Secretary of Defense said DoD would build five or six production V-22s, the number of aircraft would be as determined by the contractor's proposal.

o In response to a request to outline the steps in awarding a contract, the request for proposal would be released on August 11, 1992; the contractor must respond by September 30, 1992; the proposal would be reviewed; and it was estimated the contract would be awarded by the end of December 1992.

While the Acting SECNAV recognized the need for a DAB review, no review was held until June 30, 1993, much later than the award of the EMD contract in October 1992. Further, the timing of the contract award was advanced from late December 1992 to October 1992. According to several current and former DoD officials, the White House directed the accelerated timing so that the award could be announced before the Presidential election.

In addition to the Acting SECNAV's testimony and Program executive officer's memorandum, the Defense Acquisition Executive Summary, dated October 25, 1992, also referenced the Acting SECNAV's direction on V-22 EMD:

Based on SECNAV direction, a new program (EMD Derivative) is being established with a planned letter contract award of October 1992 and future DAES [Defense Acquisition Executive Summary] assessments . . . will address the "new" program. The EMD Derivative program will procure four new production representative

⁵Formerly called Full-Scale Development.

Utilization of the Defense Acquisition Board Review Process

aircraft to demonstrate the ability of the V-22 aircraft to perform the MLR ORD [operational requirements document] requirements.

Actions by the Former Navy Acquisition Executive. On August 10, 1992, the Navy acquisition executive (former ASN[RD&A]) approved the issuance of a contract to Bell-Boeing for a V-22 Derivative Demonstration Program by signing a Justification and Approval, which stated:

The proposed contractual action will provide, pursuant to an understanding between the Secretary of Defense and Congress, for the procurement of a V-22 derivative design and an advanced technology demonstration. The objective is to demonstrate through sensible aircraft prototyping, the ability for the V-22 derivative design to satisfactorily and affordably meet the operational needs as specified in the USMC [U.S. Marine Corps] Medium Lift Replacement (MLR) Operational Requirements Document. . . . This acquisition will be funded with the funds included in the FY92 Defense Appropriations Act for V-22 plus such funds, if any, earmarked for the V-22 by Congress in FY93.

On September 25, 1992, the ASN(RD&A) wrote a memorandum to the SECNAV concerning the "V-22 Derivative Demonstration Program," which stated:

Attached is my current understanding of Bell-Boeing's proposed response to our RFP [request for proposal]. The response includes a derivative demonstration program and options for a more complex follow-on program (E&MD). I suggest we stick with the basic demonstration program which will require \$665 million in FY 1993.

The Acting SECNAV responded to the ASN(RD&A) memorandum with a hand-written note that stated, "Jerry - As we discussed today 10/9, proceed as agreed to vice this approach. Thanks. Sean." The former ASN(RD&A) told us he didn't recall the meeting with the Acting SECNAV but all documentation implied a Department decision to proceed with EMD, so he must have authorized it.

The authority of the USD(A) to manage major programs, provided by DoD Directive 5134.1, is not available to Service Secretaries for Acquisition Category ID programs. Although the SECNAV is part of the streamlined chain of authority for programs that are Category IC and below, he is not in the chain for Category ID programs such as the V-22. Therefore, the SECNAV had no authority to direct the award of the EMD contracts. Further, documentation does not support that the apparent direction issued by the Acting SECNAV was exactly as intended by Congress or the Office of the Secretary of Defense. Also, the failure of the USD(A) to take an active role in the V-22 restructure removed the discipline of DAB oversight from the process.

Defense Acquisition Board Review. Although in August 1992, the SECNAV articulated the need for a DAB review to issue the request for proposal and approve the Program, no DAB review was held until June 30, 1993. The purpose of that review, as stated in the resulting USD(A) guidance memorandum, dated August 5, 1993, was to establish a decision framework for a formal DAB review to be held in November 1993 and to provide guidance to

Utilization of the Defense Acquisition Board Review Process

the Navy on the necessary actions to support DAB decisions. Thus, the initial DAB review, which was not held until 8 months after the first EMD letter contract was awarded, was basically a planning meeting for a more formal DAB review, termed "Milestone II-Plus," in which major Program decisions were to be made and which now is not scheduled until September 1994, 23 months after award of the EMD contract.

In his February 24, 1993, memorandum to ASN(RD&A), the Program executive officer for the V-22 Program strongly recommended that a DAB program review be scheduled as soon as possible "to formally document approval to enter EMD and provide definitive guidance concerning operational requirements and production planning." We asked the Program executive officer and the Program manager whether the absence of an acquisition decision memorandum for EMD was affecting the contractor's performance. The Program executive officer replied that performance was affected and was manifested by a reluctance to invest, hire a larger workforce, and position for production. The Program manager added that this effect also applied to vendors and subcontractors.

Validation of Requirements. The V-22 entered EMD in October 1992 and has continued development since then without having a requirement validated by the Joint Requirements Oversight Council (JROC).

DoD Instruction 5000.2 states that a program may not enter EMD unless the milestone decision authority confirms that performance objectives and thresholds have been validated. For Acquisition Category I programs, the JROC is the validation authority for all mission needs and for performance objectives and thresholds in the acquisition program baseline for programs coming to the DAB for review.

The Joint Services Operational Requirement (JSOR) for the Advanced Vertical Lift Aircraft, dated April 1985, established a joint operational requirement for an aircraft that would provide the Army, Navy, Air Force, and Marine Corps the ability to conduct combat, combat support, and combat service support missions requiring vertical takeoff and landing capabilities.

The FSD contract required the aircraft to meet the JSOR in the 12-aircraft pilot production option, which would have followed production of the six FSD aircraft. However, the Government did not exercise the production option as it was terminated via an Under Secretary of Defense memorandum, dated December 1, 1989.

On March 11, 1992, in a memorandum to the USD(A), the ASN(RD&A) stated that it was impossible to meet JSOR requirements but it was possible to meet MLR requirements. On April 2, 1992, in a letter to the Speaker of the House, the Secretary of Defense stated that

the V-22 currently does not satisfy the existing Joint Service Operational Requirement (JSOR), and it will require substantial redesign and testing before it will. . . . To fabricate six additional test aircraft that would meet the JSOR . . . would require \$2.8 billion to execute. . . . The ability of the aircraft to satisfy the JSOR would

Utilization of the Defense Acquisition Board Review Process

not be demonstrated until July 1999, two and a half years later than the December 1996 date specified in the statute. . . . We do not, however, intend to execute this program because it is not affordable within the overall constraints we face on Defense resources.

On May 7, 1992, in preparation for the MLR Milestone 0 review, the JROC reviewed a draft MLR ORD and the mission-need statements for the Navy's Amphibious Search and Rescue and Helicopter Combat Support. It recommended that MLR proceed into the Concept Exploration and Definition phase and that a cost and operational effectiveness analysis be performed to develop and refine key parameters of the MLR requirement. The JROC stated that:

- o It could not support the specific values expressed in the draft MLR ORD; it would review and validate key parameters before Milestone I; and it asked the Marine Corps to further define the threat, scenario, and capabilities required.

- o A new mission-need statement for the Marine Corps was not necessary since the JSOR adequately stated the broad, generic need for a follow-on to the CH-46E and the CH-53D helicopters.

- o The requirements for Amphibious Search and Rescue and Helicopter Combat Support may be met with MLR aircraft, but those for long-range Special Operations Forces cannot likely be met by the MLR solution.

On June 10, 1993, the JROC validated the Special Operations Advanced Multi-Mission Vertical Lift Aircraft (MV-X) mission-need statement, establishing the requirement for a deep infiltration and exfiltration capability. However, it stated that, in light of a rapidly changing strategic environment, the JSOR was valid only as a statement of the broad, generic mission need for an MLR aircraft (CH-46E follow-on).

The USD(A), in an August 5, 1993, guidance memorandum resulting from the June 30, 1993, V-22 DAB review:

- o directed preparation of ORDs for both the MLR and MV-X;

- o directed preparation of a cost and operational effectiveness analysis that addressed both MLR and MV-X requirements;

- o requested that the JROC review the ORDs proposed by the Navy and the Special Operations Command before the DAB and recommend whether a single joint requirement should be adopted; and

- o directed the Navy, pending the November 1993 DAB review, to continue the development program while contractually preserving full joint capability to the greatest extent possible (i.e., JSOR-equivalent specifications).

We compared the JSOR to the MLR ORD to determine the main difference in requirements. We found that although the payload requirements were the same (i.e., an external lift capability of 10,000 pounds), the main difference was

Utilization of the Defense Acquisition Board Review Process

speed. Specifically, the JSOR required a continuous cruise speed of at least 250 knots and a dash speed of 275 knots compared to the MLR ORD, which required a continuous cruise speed of at least 180 knots (200 knots desired). We discussed MLR requirements with the MLR Program manager, who stated that the maximum speed for existing helicopters was about 160 knots. In a June 28, 1993, memorandum to the USD(A), the Director, Tactical Systems, stated, "MLR was seen as a helicopter instead of a tilt-rotor, but the Marines documented a requirement of 180 knots max speed which is well short of the 250-knot regime but very heroic for a helicopter."

On December 6, 1993, the JROC reviewed the proposed MV-X and MLR requirements based on the cost and operational effectiveness analyses. It validated key performance parameters for the MV-X, but, as in May 1992, the JROC could not validate them for the MLR, citing concerns with speed and self-deployability. The proposed threshold for speed was now 250 knots versus the 180 knots specified in the earlier MLR ORD. Another JROC meeting was scheduled for July 1994 to support the September 1994 DAB review. At the July 1994 meeting, the JROC plans to reconsider MLR key performance parameters and evaluate joint program potential of the MV-X and MLR requirements.

The statement of work in the EMD letter contract provides that one objective of EMD is to demonstrate the ability of the design to satisfactorily meet the operational needs of MLR. However, the statement also adds that "when proposed specification changes degrade the V-22's capability to meet the JSOR, the contractor shall provide an analysis of cost and effort to restore that capability."

Although the EMD contract requires the contractor to demonstrate MLR requirements, the JROC has rejected MLR key performance parameters and does not plan to reconsider them before July 1994. Also, because the JROC stated in June 1993 that the JSOR was valid only as a statement of the broad, generic mission need for an MLR aircraft, the JSOR is not a valid requirements document for the V-22. Therefore, the USD(A) direction to contractually preserve full joint capability to the greatest extent possible (i.e., JSOR-equivalent specifications) was not based on valid requirements.

Validity of Acquisition Program Baselines. The V-22 Program has not had a valid acquisition program baseline for more than 2 years. Since November 1991, the Program has operated first with a breached baseline and then with an invalid baseline.

The V-22 FSD Program operated with a breached baseline from October 22, 1991, (when the Deputy Program executive officer notified the ASN[RD&A] of the breaches) through October 22, 1992, (when the FSD Program was terminated and the EMD letter contract was awarded). On November 18, 1991, the Navy submitted to the USD(A) the required notice of cost and schedule breaches to the revised development baseline, dated December 30, 1990. However, it did not submit a proposed baseline revision because of its pending analysis of the aircraft #5 mishap, outstanding contractual issues, and need for guidance from the Office of the Secretary of Defense on congressional budget

actions. The Navy set the second quarter of FY 1992 as a goal for establishing a new baseline in which it would establish new schedule, technical, and cost parameters to complete the existing FSD contract. However, the new baseline was never established because the Secretary of Defense considered the congressional mandate unachievable. The eventual compromise resulted in termination of FSD and start of EMD.

Since October 22, 1992, the V-22 EMD Program has been operating without a valid baseline since the breached FSD baseline continued to be used. The Performance Management action officer, Office of the USD(A&T), has correctly noted in Defense Acquisition Executive Summary Program Assessment Justification Reports since February 1993 that a program deviation report and a revised baseline should be submitted. However, the Navy has acknowledged in its V-22 Defense Acquisition Executive Summary reports since January 1993 that a baseline had not been approved for EMD and that the reported baseline values were not valid. Also, the Navy could not realistically comply with the request for a revised baseline because the USD(A) did not issue guidance until August 5, 1993, on fundamental documentation requirements supporting a baseline (i.e., an ORD and a test and evaluation master plan).

Without a valid baseline, the DAB has not had and will not have a formal measure with which to judge Program success at the Milestone II-Plus review. Also, because of a lack of DAB oversight, the Navy obligated \$615 million on two EMD contracts with a current value of more than \$2.79 billion and restructured the V-22 Program without proper authorization, a DAB review, a validated requirement, or a valid baseline.

Program Oversight During Full-Scale Development

Reviews of the V-22 Program during FSD were not always held when needed to address significant issues. The Program experienced major disruptions caused by DoD and congressional actions beginning in April 1989 as well as chronic cost, schedule, and performance problems. However, no DAB or CSC review was held until January 1992 although a Navy program decision meeting was held in June 1991. Further, the focus of those reviews was on satisfying congressional requirements rather than addressing programmatic issues. Also, decisions resulting from the Navy meeting were made without documented USD(A) approval.

Program Disruptions. In an April 1989 amended FY 1990 budget submission, the Secretary of Defense deleted all funding after FY 1989 for the V-22 Program. However, in November 1989, Congress reversed the Secretary's action in the FY 1990 Appropriations Act by providing \$255 million for research, development, test, and evaluation of the Program.

In December 1989, DoD terminated the production option on the FSD contract, which had been exercised in March 1989, and did not request V-22 Program funding in the FY 1991 budget submission. However, in October 1990, in the

Utilization of the Defense Acquisition Board Review Process

FY 1991 Appropriations Act, Congress provided the V-22 Program with \$238 million in research, development, test, and evaluation funding (which included \$200 million transferred from FY 1989 procurement funds) and \$165 million in new procurement funding. Also, in April 1991, Congress directed the Navy in the FY 1991 Dire Emergency Supplemental Act to obligate the \$200 million in FY 1989 procurement funds for V-22 Program within 60 days.

In November 1991, in the FY 1992 Appropriations Act, Congress provided \$625 million in research, development, test, and evaluation funding and transferred the \$165 million in FY 1991 procurement funding to FY 1992 research, development, test, and evaluation funding to build three new production-representative aircraft. Those aircraft were planned to demonstrate the full operational requirements of the JSOR by December 31, 1996. Also, the Secretary of Defense was directed to provide within 60 days the total funding plan for the combined \$790 million and a schedule to complete Phase II FSED.

The House of Representatives' bill for the FY 1993 Authorization Act had provided for a much greater scope of effort and financial commitment to the V-22 Program than the Senate amendment. However, the House receded in favor of the Senate amendment, which deleted the House's requirement for DoD to build six production-representative aircraft and request future years' funding. The conferees also recommended that DoD close out the FSD contract in favor of a new cost-reimbursable contract. The Conference Report, dated October 1, 1992, stated:

The House bill contained a provision (sec. 211) that would require the Department of Defense to develop, manufacture, and operationally test three production representative V-22 aircraft. These would be in addition to the three production representative aircraft authorized and appropriated in fiscal year 1992. The House provision would also require the Secretary of Defense to request necessary funds in future budget requests to complete development, manufacture, and operational testing of six production representative V-22 aircraft.

The Senate amendment included a similar provision (sec. 211) which would not require the Secretary of Defense to request additional funds in future budget requests for the V-22 aircraft program.

The House receded with an amendment that would authorize the use of \$755 million only for the V-22 Osprey aircraft program, and direct the use of FY 1993 and prior year funds only for the development, manufacture, and operational testing of the V-22 Osprey or derivative tilt-rotor aircraft.

The Conferees note that the current V-22 full-scale development (FSD) program is being operated under a fixed-price contract. Many of the terms and conditions under which that agreement was reached are no longer valid. Given the change in program direction proposed by the Secretary of Defense, the conferees believe that it is no longer cost-effective or prudent to complete a number of tasks called for in the existing FSD contract. The conferees understand that any new V-22 contract will be a cost-plus type instrument. Since it would be difficult to manage various phases of the effort under two such

Utilization of the Defense Acquisition Board Review Process

disparate contacting vehicles, therefore, the conferees believe that the Defense Department should move expeditiously to reduce the scope of the FSD contract, as appropriate, and close it out.

Program Performance. From March 1989 through October 1992, the V-22 Program manager's estimate at completion for the FSD contract showed a worsening trend in cost performance, overrunning the ceiling price of \$1,825 million by \$23 million (1-percent overrun) in March 1989 and climbing to \$488 million (27-percent overrun) by October 1992. Also, since December 1989, quarterly Defense Acquisition Executive Summary reviews by Office of the Secretary of Defense staff highlighted unfavorable trends in cost, schedule, and performance.

In August 1991, based on allegations of deliberate understatement of V-22 development costs raised by an anonymous Bell Helicopter employee, the Comptroller of the Department of Defense directed the Defense Contract Audit Agency to perform an audit of FSD contract performance. The audit found that

- o the FSD contract was 2-1/2 years behind schedule, contractor total program losses could approach \$462 million, and significant risk remained of further schedule slippage and cost growth;

- o major problems were being experienced with all development tasks: design, manufacturing, and flight testing;

- o aircraft weight was 2,900 pounds heavier than FSD-guaranteed weight, but the contractor was not expected or required to redesign or modify FSD aircraft; and

- o FSD Phase II efforts were not funded for aircraft modifications.

Program Reviews. No DAB or CSC review was held from December 1986⁶ until January 1992 although a Navy program decision meeting was held in June 1991. Further, those meetings focused on satisfying congressional requirements rather than addressing programmatic issues. Also, decisions resulting from the Navy meeting were made without documented USD(A) approval.

Navy Program Decision Meeting. The purpose of the June 6, 1991, Navy program decision meeting was to decide how to comply with the Dire Emergency Supplemental Act. An issue discussed at the first session of the meeting was major program status and whether the USD(A) should decide on obligating \$200 million. The attendees determined that since this decision was not for a program milestone and the Navy was just continuing development, the Navy was free to decide. A related issue discussed at the second session was whether the USD(A) had to approve the award due to the threshold of

⁶In December 1986, the Defense Systems Acquisition Review Council (forerunner of the DAB) held a program review, which authorized continued FSD of the V-22 Program but noted that affordability remained a problem.

Utilization of the Defense Acquisition Board Review Process

modifications awarded under firm-fixed-price contracts. Naval Air Systems Command (NAVAIR) was tasked to resolve the issue with USD(A) staff and inform the ASN(RD&A) of any action necessary.

Four days later, without USD(A) action, the Navy obligated the \$200 million for existing FSD efforts under contract, field activities support, an engine upgrade modification to the existing contract with Allison, and award of a \$75 million cost-plus-fixed-fee "FSD Phase II" letter contract to Bell-Boeing for a drive system and engine nacelle upgrade. Since FSD Phase II was a new cost-reimbursable contract for additional development rather than a modification of the existing fixed-price FSD contracts, we believe that formal USD(A) approval should have been obtained before award was made.

Conventional Systems Committee Program Review. On January 14, 1992, a CSC program review was held to prepare for a DAB review on January 17, 1992.⁷ Its focus was on the form of the response to the Congress and the contracting strategy to accomplish it. The Committee concluded that the alternatives requiring only FY 1992 funding were most consistent with the previous Department decision that the Program was unaffordable. The CSC Chairman tasked the Director, Defense Procurement, to assess potential grounds for termination for default of the FSD contract; DoD General Counsel to consider legal implications of alternatives; the Navy to review a suggestion to consider a commercial prototype program by re-engineering aircraft #6 to eliminate Marine Corps-peculiar requirements; and the JROC to review the required operational capability to ensure it was current and valid.

Defense Acquisition Board Program Review. The purpose of the January 17, 1992, DAB program review was to review alternatives for a V-22 acquisition plan that would satisfy the statutory requirements of the FY 1992 Authorization and Appropriation Acts. In the resulting acquisition decision memorandum, dated January 21, 1992, the USD(A) stated that it would be premature for him to authorize a new development contract for the V-22 until he had determined that the contractor had satisfied all performance requirements of the original fixed-price contract. Therefore, the Navy was requested to report within 30 days on:

- o what performance the contractor was required to demonstrate on the existing \$1.8 billion contract,

- o what additional contributions to the achievement of Program requirements would be provided by the separate contracts for the technology effort entered in June 1991,

- o what additional funding requirements the Government needed to fund to develop an aircraft that met the JSOR, and

- o what the estimated cost would be of a follow-on contract for the additional requirements.

⁷The DAB review was directed by the USD(A) on December 16, 1991, to decide how to meet congressional requirements.

The USD(A) stated that on receipt of the requested information, he would decide on further development efforts.

Conventional Systems Committee Special Program Review. On April 9, 1992, a CSC special program review was held to receive the Navy plan for a Performance Demonstration Program, review the status of issues discussed at the January 1992 CSC and DAB meetings, and make appropriate recommendations to the DAB Chairman. In a memorandum to the USD(A), dated May 7, 1992, the CSC Chairman concluded that the full V-22 EMD program was unaffordable; compliance with statutory language could not be met with available funds; the Performance Demonstration Program did not make adequate progress to justify the expenditure; the MLR requirement needed to be validated; and, once the requirement was validated, a new cost and operational effectiveness analysis was needed to address alternatives to meet the MLR requirement.

In an acquisition decision memorandum, dated May 15, 1992, the USD(A) concurred with the conclusions of the CSC Chairman and stated that progress was needed on the MLR program. Further, the USD(A) requested the Navy, Marine Corps, and JROC to review and define the MLR requirement; the Navy to coordinate Milestone 0 and I reviews for the MLR program; and the Assistant Secretary of Defense (Program Analysis and Evaluation) to develop and staff MLR cost and operational effectiveness analysis guidance. However, no V-22 DAB review was held. The debate continued on the V-22 Program until the Secretary of Defense issued his July 2, 1992, letter to Congress that outlined the advanced technology and operational demonstration program.

Milestone II-Plus Review

Although limited time was allowed to prepare for the planned December 9, 1993, DAB Milestone II-Plus review, documentation required by the USD(A&T) for the review was reasonable and the review had the potential to correct deficiencies noted in this report, including a lack of current program documentation such as an acquisition program baseline. However, at the DAB readiness review on December 8, 1993, the USD(A&T), citing deficiencies of the cost and operational effectiveness analysis, postponed the review and later rescheduled it for September 1994.

DAB Review Process. The DoD Instruction 5000.2 states that the DAB milestone review process will begin with a planning meeting at least 6 months before the DAB milestone review. Draft documentation will be provided to the DAB Executive Secretary no later than 45 days before a scheduled DAB Committee review. The Office of the Secretary of Defense staff will review the documentation and identify major issues at a documentation review meeting held no later than 30 days before a DAB Committee review and a memorandum will be coordinated with DAB principals and issued to the Component acquisition executive within 5 days of the review. The DoD Instruction also provides that the USD(A&T) may hold DAB special program reviews between milestone

Utilization of the Defense Acquisition Board Review Process

reviews to address either the overall program status or particular issues of concern. Documentation required should be tailored to the specific requirements for the program review.

Guidance and Documentation. The USD(A) memorandum, "V-22/MLR/MV-X Guidance," dated August 5, 1993, provided guidance for a formal DAB review of the V-22 Program. It also stated that the review was intended to support the Secretary's decisions on the content of the budget and the future years Defense program. The Navy and the Special Operations Command were directed to prepare for a November 1993 DAB review that would consider the V-22 as a candidate for a "Milestone II-Plus" decision in conjunction with the requirements of the MLR and the MV-X. The memorandum required preparation of the following documentation:

- o integrated cost and operational effectiveness analysis,
- o operational requirements documents for MLR and MV-X,
- o integrated program summary,
- o acquisition program baseline,
- o draft test and evaluation master plan, and
- o Milestone II-equivalent cost information.

The level of documentation required by the USD(A) approximated that of a Milestone II review and was reasonable under the circumstances.

Postponed Decisions. The DAB review date was driven by the desire to include the results of the review in the FY 1995 budget cycle, with the main issue being whether the V-22 would be a joint Program encompassing the MLR and MV-X requirements. However, because the DAB review was postponed, the main issue was not decided and the USD(A&T) directed the Navy to redesignate the \$2.55 billion programmed in FYs 1996 through 1999 for V-22 procurement to "Marine Corps Medium Lift Alternative."⁸ While the desire to decide before preparation of the DoD Budget is understandable, we believe the limited time allowed to prepare and review V-22 Program documentation for the scheduled DAB Milestone II-Plus review contributed to the last-minute cancellation of the December 1993 review and deferral of key V-22 Program decisions for another 9 months. For a review of this magnitude, direction should have been given 26 weeks before the review rather than only 14 weeks before, as was the case for this Program. Documents such as a cost and operational effectiveness analysis are difficult to generate in a short time.

Impact of Postponed Decisions. Rather than a desire to meet the budget submission, the driving concern should have been the need to first decide on the V-22, then to definitize the EMD contract. However, the Navy definitized the

⁸The FY 1995 President's Budget requested \$497 million for continued development of the Program. Procurement funds were not requested.

\$2.65-billion EMD contract in May 1994, long before the DAB review was planned to select the medium-lift alternative and before the JROC planned to validate MLR requirements. This sequence of events has two adverse effects:

- o The EMD contract was definitized without the availability of several requirements including an approved acquisition program baseline, ORD, or test and evaluation master plan.

- o The termination liability will increase automatically and rapidly from the current level.

Termination liability will increase *automatically* because ASN(RD&A) approval for increasing the limit of Government obligation will not be required. Further, termination liability would increase *rapidly* because the contract has reached the point where expenditure rates accelerate. Specifically, after 17 months of EMD (through March 31, 1994), the termination liability approximated \$487 million. However, during the 6 months between March 31, 1994, and September 30, 1994, termination liability is expected to more than double from \$487 million to \$977 million. Consequently, if the September 1994 DAB review were to result in selection of an alternative other than the V-22, the cost to terminate the definitized EMD contract would be an additional \$490 million (\$977 million less \$487 million).

If the letter contract had remained undefinitized, the limit of Government obligation would have had to be increased via contract modifications. The modifications would have directly affected the contract price, and the ASN(RD&A) would have had to approve each modification that was more than \$50 million. Given the expenditure rate in the Bell-Boeing proposal of December 1993, we estimated that FY 1993 and prior funds would have been sufficient to fund termination liability for the EMD program through December 1994 (\$1,205 million).

Causes for Ineffectiveness of the DAB Process

Main Causes. The DAB process for the V-22 Program has not been effective for the following main reasons:

- o After V-22 pilot production was cancelled in December 1989, no subsequent milestone review was required and special program reviews were not held except to satisfy congressional requirements.

- o The former USD(A) did not ensure that DAB reviews were held and guidance was issued when needed, major decisions were documented, and only the proper authority issued direction.

- o The former Navy acquisition executive did not ensure that the decision to award the EMD contract was properly authorized.

Utilization of the Defense Acquisition Board Review Process

o The V-22 Program was allowed to proceed into the second year of EMD without a formal decision on whether the V-22 was the preferred alternative to meet either the MLR needs of the Navy or the long-range needs of the Special Operations Command.

Contributing Causes. Required controls were bypassed for contract review and approval that should have identified proper authorization for EMD. Also, terminology to describe proposed V-22 programs may have caused confusion as to what program was intended or understood.

Bypassed Controls. To meet the accelerated schedule for awarding the EMD contract, the Navy bypassed required controls that should have ensured proper review and approval of the EMD contract and identified proper authorization. Specifically, those controls were approval for use of letter contracts, certification of urgency, revision of the Justification and Approval, and legal review of the contract.

Use of Letter Contracts. The Defense Federal Acquisition Regulation Supplement prescribes policies and procedures implementing title 10, United States Code, section 2326 for undefinitized contract actions. It cites a letter contract as an example of an undefinitized contract action and states:

The contracting officer shall obtain approval from the head of the contracting activity before entering into a UCA [undefinitized contract action]. The request for approval must fully explain the need to begin performance before definitization, including the adverse impact on agency requirements resulting from delays in beginning performance.

UCAs shall contain definitization schedules which provide for definitization by the earliest of the following dates-- (1) The date which is within 180 days after issuance of the action (this date may be extended but may not exceed the date which is 180 days after the contractor submits a qualifying proposal); or (2) The date on which the amount of funds spent under the contract action is equal to more than 50 percent of the not-to-exceed price.

The NAVAIR Instruction 4200.33, "Undefinitized Contractual Actions," April 11, 1988, in effect when the EMD contract was awarded, states:

The use of undefinitized contracts is not good business since the contractor bears minimum cost risk and operates in a cost-plus mode until negotiations are complete. The undefinitized contract provides very little incentive for the contractor to control costs due to the fact that costs incurred, up to the time of negotiation, are usually accepted by the Government.

The use of letter contracts for V-22 EMD was not justified based on the Defense Federal Acquisition Regulation Supplement or the NAVAIR Instruction. The Navy did not make either the required request for approval to use the letter contracts or the required explanation of the adverse impact on agency requirements. Instead, the letter contract was justified based on "uncertainties involved in contract performance," as stated in the Justification and Approval. Further, before the letter contract was awarded, the Navy recognized that it

would not be definitized within even twice the required 180 days. The Business Clearance, approved on October 20, 1992, established November 1, 1993, as the date for contract definitization. However, that action did not occur until May 1994; therefore, the letter contract remained undefinitized for 19 months. For the reasons stated in the NAVAIR Instruction, letter contracts in general are not good business, especially for an entire phase of a major program.

Certification of Urgency. NAVAIR Instruction 4200.33 required an urgency certification when urgency of the requirement necessitated use of a ceiling-priced order. Also, a statement was to be provided that fully addressed the urgency. The criteria for urgency included: safety of flight; readiness impact: "The deployment of ready systems would be jeopardized"; and exceptions to the Defense Federal Acquisition Regulation Supplement. The Instruction also stated, "Use of a ceiling priced order will be kept to an absolute minimum, and will not be used . . . in any case where the requirements are not clearly defined."

The Acting Program executive officer approved a NAVAIR Ceiling-Priced Order Certification of Urgency on October 13, 1992, to "design, fabricate, and flight test 4 EMD aircraft and modify 2 FSD aircraft." The estimated ceiling price was \$1.355 billion. The urgency rationale stated, "Urgent contractor action is required to comply with the congressional and Department of Defense direction to initiate the V-22 EMD program in order to meet fleet readiness." The urgency rationale "to meet fleet readiness" was invalid since there was no requirement for the V-22 and it was not a ready system. Further, the rationale was not fully explained as required. Also, the \$1.355 billion ceiling price represented the cost of a Derivative Demonstration Program, not EMD, for which \$2.0 billion was requested in the Business Clearance on October 20, 1992. Discussions with NAVAIR officials indicated "readiness" seemed the best choice of the three options. In fact, the real reason for urgency was the imposed deadline to award the contract.

Revision of the Justification and Approval. NAVAIR Instruction 4200.31B, "Requirements for Preparation and Approval of Justification and Approvals and Determination and Findings Under the Competition in Contracting Act," August 31, 1992, states,

A J&A [Justification and Approval] must reflect the strategies contained in the corresponding AP [Acquisition Plan]. If any of the strategies change, necessitating an AP amendment, an amendment to the J&A or a formal notice of the change to the J&A approval authority for concurrence shall be processed.

The Acquisition Plan changed as follows:

- o The Acquisition Plan, approved August 17, 1992, described the program as covering "a one-time procurement of a V-22 derivative design and an advanced technology operational demonstration." The plan continued, "This Acquisition will be funded with funds included in the FY92 Defense Appropriations Act for V-22 plus such funds, if any, earmarked

Utilization of the Defense Acquisition Board Review Process

for the V-22 by Congress in FY93." The Annex mentioned only the team of Bell-Boeing as the proposed sources and stated the proposed contract was expected to be awarded in December 1992.

o The Acquisition Plan, Revision 1, approved October 29, 1992, (7 days after the contract was awarded) described the program as covering "a one-time procurement of a V-22 Engineering and Manufacturing Development (EMD) Derivative Program." The revision continued, "This Acquisition will be funded with FY92 and FY93 appropriated funds plus other funds made available in FY94 - FY99 to complete the program." The Revision added an upgraded engine to the program, mentioned the teams of Bell-Boeing and Allison as the proposed sources, and stated the proposed contracts were expected to be awarded in October and December 1992, respectively.

Although the former ASN(RD&A) acknowledged that a revised Justification and Approval should have been executed, none was prepared.

Legal Review. The Navy Acquisition Procedures Supplement, January 1992, states, "Contract documents shall be forwarded to the appropriate attorney or attorneys in the OGC [Office of General Counsel] for review as to form and legality and any additional pertinent comment or advice." The NAVAIR Instruction 5400.1B, January 15, 1988, states "Counsel (AIR OOC) [NAVAIR Office of Counsel] is responsible for ensuring the proper form and legality of all NAVAIRHQ [Headquarters, NAVAIR] contracts, modifications, and amendments."

However, NAVAIR Contracting officials did not provide the EMD contract for legal review and the NAVAIR Office of Counsel did not insist on this. Also, NAVAIR Counsel was aware that no formal authorization for EMD existed but apparently did not raise those issues to the Navy Office of General Counsel. Either performing a legal review or elevating the issues should have identified the inconsistency between the Justification and Approval and the contract; highlighted the need for a revised Justification and Approval; and, therefore, required the Navy acquisition executive to make a formal decision on EMD.

Confusing Terminology. The wide array of terms used to describe proposed V-22 programs such as FSD Phase II; Phase II FSED; FSED Follow-on; advanced technology and operational demonstration; Derivative Demonstration Program: Basic, Follow-on, Supplement I, and Supplement II; Derivative EMD; and EMD may have caused confusion as to what program was intended or understood. Sometimes different terms were used to describe the same program and sometimes the same term was used to describe different programs. For example, FSD Phase II was used by

o the Navy to describe a contract awarded in June 1991 for a drive train/engine nacelle upgrade,

o Congress in the FY 1992 Appropriations Act to describe additional effort directed on the FSD contract,

o the Acting SECNAV in August 1992 to describe DoD's proposal to Congress, and

o the Comptroller of the Department of Defense to describe EMD in a December 1992 Program Budget Decision regarding the V-22 Program.

Conclusion

We found no justifiable basis for the dramatic change in the V-22 Program from an advanced technology operational demonstration, normally a part of the Demonstration and Validation phase of the acquisition process, to a full EMD effort including manufacture of production-representative units for initial operational test and evaluation. Such an EMD program should only have been initiated if DoD had clearly made a decision concerning fulfilling the MLR and MV-X requirements.

The Navy made key decisions that the former USD(A) should have approved and formally documented, especially authorization to enter EMD. Compliance with congressional direction does not exempt DoD officials and staff from fulfilling their responsibilities to provide proper guidance and oversight when possible. When the decision was made to enter EMD, the USD(A) should have been directly involved via the DAB process.

The former ASN(RD&A) and other Navy officials expressed concern about terminating an FSD contract that was a fixed-price instrument and awarding a cost-reimbursable contract for the same effort. This concern supported continuing with a Derivative Demonstration Program versus a full EMD effort because a decision to actually field the V-22 had not, and still has not, been made. In fact, the EMD contract is for aircraft principally designed to meet a lesser requirement, that of the MLR rather than that of the previous JSOR.

We strongly disagree with the use of undefinitized EMD letter contracts for major programs. In particular, until May 1994, the V-22 airframe EMD letter contract remained undefinitized for 19 months. Such contracts are disadvantageous because DoD assumes increased cost risk in the award, obligation, and negotiation process. While the timing of the letter contract award was influenced by several factors, they should not have precluded the DAB from establishing effective program oversight, including approval of an acquisition program baseline for performance measurement purposes.

The V-22 Program has been in EMD since October 1992 without a valid baseline or requirement. Further, with USD(A&T) approval, the Navy definitized the \$2.65-billion contract before the DAB review was held to select a medium-lift alternative and before the JROC validated the requirements. In fact, the JROC specifically decided not to validate the requirement without additional justification. Definitization without validated requirements can lead to costly contract modifications. Although properly authorized, that action

Utilization of the Defense Acquisition Board Review Process

enabled Government obligations on the contract to continue automatically. Consequently, without further action, obligations could increase regardless of the outcome of a DAB review or decision to select the V-22 to meet future medium-lift needs of the armed forces.

Until the DAB decides on the V-22, any FY 1995 funds provided should not be committed to the Program. We estimate FY 1993 and prior funds will be sufficient to fund termination liability for the EMD program at least through December 1994, well beyond the DAB decision scheduled for September 1994.

Recommendation Deleted in Final Report

In our draft audit report, we recommended that the Assistant Secretary of the Navy (Research, Development, and Acquisition) postpone definitization of the V-22 Engineering and Manufacturing Development contract and limit obligation of contract funding to no more than the FY 1993 and prior appropriations until the Defense Acquisition Board Milestone II-Plus review was held and the Defense Acquisition Executive chose the V-22 as the alternative to meet validated requirements.

Management Comments and Audit Response

On April 5, 1994, the ASN(RD&A) and the V-22 Program executive officer met with Deputy Inspector General, DoD, and his audit staff to discuss the draft audit report recommendation. Although nonconcurring with the recommendation, the ASN(RD&A) proposed alternative corrective action that included obtaining DAE approval to definitize the contract, soliciting Joint Staff concurrence with definitizing the contract, and ensuring the Government's financial commitment was appropriately limited. The ASN(RD&A) agreed to review increases in Government obligations relative to V-22 Program progress, particularly regarding prospective FY 1995 funding. Before approving such increases, the ASN(RD&A) would consider upcoming decisions by the JROC and the DAB.

The Deputy Inspector General agreed to support definitization of the EMD contract, contingent on USD(A&T) approval to definitize the contract, Joint Staff concurrence, and the ASN(RD&A)'s assurance to appropriately limit financial obligation. On April 20, 1994, the ASN(RD&A) asked the DAE to concur with the Navy plan to definitize the EMD contract. Also on that date, the ASN(RD&A) notified the Vice Chairman, Joint Chiefs of Staff, of the Navy's plan to definitize the EMD contract and asked to discuss any related concerns of the Vice Chairman. On April 29, 1994, the DAE authorized definitization; on May 2, 1994, the ASN(RD&A) issued a memorandum to the Deputy Inspector General confirming their verbal agreements; and on May 3, 1994, the Navy definitized the contract. On May 23, 1994, the Vice Chairman

Utilization of the Defense Acquisition Board Review Process

concurrent with definitization of the EMD contract but noted that such concurrence should not be construed as concurrence with specific values of requirements expressed in the JSOR, the definitized EMD contract, or the Marine Corps draft ORD. The Vice Chairman added that those decisions would be made in the upcoming JROC meeting on medium-lift issues. The full text of the management comments is in Part IV.

The alternative corrective action met the intent of our recommendation, which was to obtain proper approvals and limit Government financial obligation until DoD decisions were made on MLR requirements and V-22 production. Therefore, no additional comments are required. However, we remain concerned that further delays in the DAB Milestone II-Plus review will again result in significant increases in Government liability without a DAE decision on the production program. Therefore, we plan to follow-up on management actions to conduct the DAB review on schedule and appropriately limit DoD obligations until a decision is made.

Part III - Additional Information

Appendix A. Drawings of a V-22

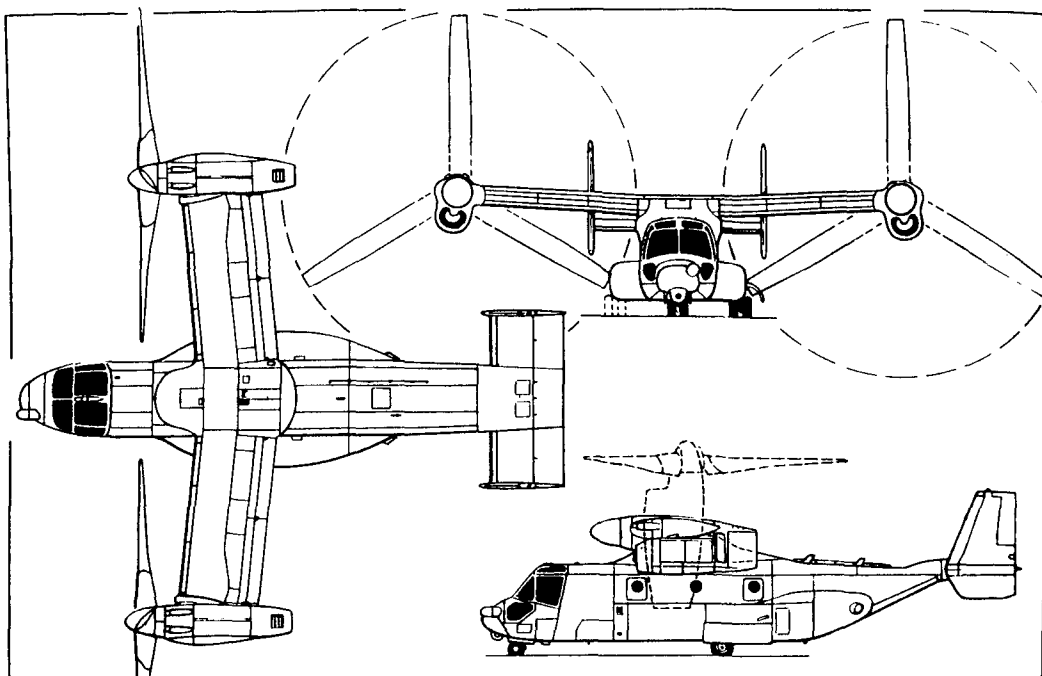

Appendix B. Chronology of Events for V-22 Program

<u>Date</u>	<u>Event</u>
4/86	Defense Systems Acquisition Review Council Milestone II review.
5/1/86	Approval for entry into FSD. Contracts signed with Bell Helicopter Textron, Inc., and Boeing Helicopter Company (Bell-Boeing); and Allison Gas Turbine (Allison).
12/18/86	Program review. Acquisition decision memorandum requested Navy to assess impact of very-important-person configuration and anti-submarine warfare variant and plan for Milestone 0/I in November 1987. Cost and operational effectiveness analysis required for variant. Army requested to complete analysis in late 1987 justifying planned use of V-22.
3/19/89	First flight of aircraft #1.
3/89	Production option exercised on FSD contract (long-lead).
4/19/89	In FY 1990 Amended President's Budget, Secretary of Defense cancelled V-22 Program funding after 1989 due to lack of affordability. He instead funded a CH-53/H-60 mix.
10/89	Congress deleted CH-53/H-60 mix and funded V-22 in FY 1990 Budget.
12/1/89	Under Secretary of Defense memorandum terminated production options for FSD contract.
4/90	Navy funded MLR in FY 1992 Program Objective Memorandum.
4/10/91	Dire Emergency Supplemental Act required Navy to obligate \$200 million in FY 1989 aircraft procurement funds for V-22 program within 60 days.
6/6/91	Navy program decision meeting held to decide how to comply with Dire Emergency Supplemental Act.
6/10/91	Navy awarded letter contract to Bell-Boeing for drive system and engine nacelle upgrade using \$75.5 million of \$200 million in FY 1989 aircraft procurement funds.
6/11/91	Aircraft #5 crashed on first flight.
6/19/91	ASN(RD&A) signed acquisition decision memorandum for Navy program decision meeting of June 6, 1991.

Appendix B. Chronology of Events for V-22 Program

- 11/26/91 FY 1992 Appropriations Act provided \$625 million for V-22 research, development, test, and evaluation and transferred \$165 million from FY 1991
- to provide new production representative aircraft which will have an objective to demonstrate the full operational requirements of the Joint Services Operational Requirement (JSOR) not later than December 31, 1996: *Provided*, That to the extent practicable, the production representative V-22 aircraft shall be produced on tooling which qualifies production design." Secretary of Defense directed to provide the total funding plan and schedule to complete Phase II FSED within 60 days of enactment.
- 12/91 Program Budget Decision 749 re-phased development funding profile of MLR program: zeroed FY 1992 and funded only \$10 million in FY 1993.
- 12/16/91 USD(A) directed V-22 DAB for mid-January 1992 to decide how to meet congressional requirements.
- 1/14/92 CSC program review.
- 1/17/92 DAB program review held to review alternatives for V-22 acquisition plan that would satisfy statutory requirements formulated by FY 1992 Authorization and Appropriation Acts.
- 1/21/92 USD(A) memorandum to SECNAV requested information on what performance the contractor is required to demonstrate on FSD contract and on what the estimated cost would be of a follow-on contract to fund additional requirements to meet JSOR.
- 1/26/92 Comptroller of the Department of Defense letter to the President of the Senate and the Speaker of the House, in response to FY 1992 Appropriations Act, stated that cost of second V-22 development phase could not be accurately estimated but gave a preliminary Navy estimate of the congressionally-directed program as more than \$2.5 billion. The letter also stated, "We do not believe it would be possible to satisfy the statutory requirement to demonstrate the full JSOR by December 1996 even were substantial additional funding to be provided."
- 2/28/92 ASN(RD&A) memorandum to USD(A) provided details of review of FSD contract and additional requirements to meet JSOR. Memo referenced meeting with the Deputy Secretary of Defense on January 24, 1992, when he asked what program the Navy could assemble within existing appropriated funds to address Marine Corps MLR requirements. Memo also stated MLR requirement is somewhat short of JSOR.
- 3/11/92 ASN(RD&A) memorandum to USD(A) provided recommendations for finitely bounded \$790 million research and development program. It stated that it is impossible to meet JSOR requirements but MLR requirements will be met.

Appendix B. Chronology of Events for V-22 Program

- 3/23/92 Speaker of the House letter to Secretary of Defense responded to Comptroller of the Department of Defense letter, January 26, 1992, and stated Congress is disappointed that its direction to proceed with Phase II V-22 FSED has not been treated with appropriate attention by DoD. It added, "Notwithstanding the reasons described in the referenced letter, it appears that the Department of Defense is not complying with the law and congressional intent." A detailed response was requested within 15 days of USD(A) review of situation.
- 4/2/92 Secretary of Defense letter to Speaker of the House stated:

The V-22 currently does not satisfy the existing Joint Service Operational Requirement (JSOR), and . . . it will require substantial redesign and testing before it will. . . . To fabricate six additional test aircraft that would meet the JSOR . . . would require \$2.8 billion to execute The ability of the aircraft to satisfy the JSOR would not be demonstrated until July 1999, two and a half years later than the December 1996 date specified in the statute. . . . We do not, however, intend to execute this program, because it is not affordable within the overall constraints we face on Defense resources.
- 4/9/92 CSC special program review.
- 5/15/92 USD(A) memorandum stated, "V-22 remains unaffordable and the program as directed by statute is unexecutable." Requested that Navy, Marine Corps, and JROC review and define MLR requirement as quickly as possible and that Navy coordinate with DAB to schedule timely Milestone 0 and I reviews.
- 6/5/92 JROC memorandum to USD(A) recommended that MLR proceed into the Concept Exploration and Demonstration phase and that a cost and operational effectiveness analysis be performed to develop and refine key parameters of the MLR requirement. The JROC stated it could *not* support the specific values expressed in the draft MLR ORD.
- 7/2/92 Secretary of Defense wrote letter to majority and minority leaders of Senate and House "to resolve the current impasse over the expenditure of fiscal year 1992 funds for the V-22 tilt-rotor aircraft." Key provisions were that FY 1992 funds would be merged with FY 1993 funds "with the resulting funds to be made available for advanced technology and operational demonstrations for the V-22 aircraft and a new medium lift helicopter."
- 7/20/92 Aircraft #4 with crew of seven crashed at Quantico, Virginia, due to failure of a section of interconnecting drive shaft.
- 7/28/92 SECNAV directed release of request for proposal to Bell-Boeing (by August 14, 1992) for a V-22 derivative advanced technology operational demonstration.
- 7/30/92 Navy placed a synopsis of acquisition of V-22-derivative advanced technology operational demonstration in *Commerce Business Daily*.

Appendix B. Chronology of Events for V-22 Program

- 8/4/92 CSC review held for MLR Program. The review recommended DAB Milestone 0 approval.
- 8/5/92 Office of the Secretary of Defense released FY 1992 funds of \$790 million to the Navy.
- 8/5/92 SECNAV testified on V-22 Program before House Armed Services Committee.
- 8/10/92 ASN(RD&A) approved Justification and Approval for EMD letter contract. The Justification and Approval stated, "The proposed contractual action will call for Bell-Boeing to provide a V-22 derivative design and to demonstrate through sensible aircraft prototyping, the ability of that design to meet the medium lift replacement needs of the armed forces."
- 8/11/92 Navy released request for proposal for derivative V-22 and demonstration of MLR ORD capability.
- 8/13/92 DAB readiness meeting held for MLR Milestone 0.
- 8/17/92 Program executive officer approved Annex H to Acquisition Plan No. A-42-37-1-40 for "a one-time procurement of a V-22 derivative design and an advanced technology operational demonstration."
- 8/18/92 DAB MLR Milestone 0 review held to examine Marine Corps requirement for MLR aircraft.
- 9/23/92 Program executive officer faxed ASN(RD&A) information on the proposal expected to be submitted by Bell-Boeing. The proposal was expected to include two separate programs: a basic program (demonstration) and a follow-on program (EMD). The NAVAIR estimate for a full EMD program was \$2.276 billion, which would require use of additional funding not yet provided.
- 9/25/92 ASN(RD&A) wrote memorandum to SECNAV that recommended sticking with the basic derivative demonstration program.
- 9/30/92 Bell-Boeing submitted proposal to NAVAIR. Proposal was for derivative V-22 and demonstration of MLR ORD capability. Price: \$1.305 billion for basic Derivative Demonstration Program; \$1.354 billion with Supplement I. Supplement II was unpriced.
- 10/1/92 In FY 1993 Authorization Act, Congress endorsed Secretary of Defense's proposal and authorized use of \$755 million of FY 1993 and prior year research, development, test, and evaluation funds only for development, manufacture, and operational testing of V-22 Osprey or derivative tilt-rotor aircraft.

Appendix B. Chronology of Events for V-22 Program

- 10/9/92 Acting SECNAV responded to ASN(RD&A) memorandum of September 25, 1992, by writing a note on the memorandum that stated, "Jerry - As we discussed today 10/9, proceed as agreed to vice this approach. Thanks. Sean."
- 10/9/92 Acting SECNAV stated in letter to Rep. Curt Weldon (R-PA), "The exact amounts required for contract obligation cannot be determined until we complete an evaluation of the recently received responses to our RFPs [requests for proposal] for a V-22 Derivative Demonstration Program and alternative advanced technology demonstration studies."
- 10/13/92 Contracting officer and deputy Program manager signed Procurement Planning Agreement for an "EMD Derivative Program." The expected date of contract award was October 19, 1992.
- 10/13/92 Acting Program executive officer approved Certification of Urgency to "design, fabricate, and flight test 4 EMD aircraft and modify 2 FSD aircraft." Estimated ceiling price: \$1.355 billion. Urgency rationale was "to meet fleet readiness."
- 10/17/92 Bell-Boeing representative signed EMD contract.
- 10/19/92 Program executive officer authorized contracting officer to proceed with contract award for procurement of V-22 EMD effort to include modification of two existing aircraft, four new production-representative aircraft, and a full flight test program to include operational evaluation. Also authorized modification of FSD contract to delete all remaining work.
- 10/20/92 Business Clearance approved for award of a cost-reimbursable letter contract to Bell-Boeing for modification of two existing FSD aircraft and the design, development, fabrication, and test of four new EMD aircraft. Cumulative limitation of Government liability requested: \$2.0 billion. Initial funding increment to be obligated: \$550 million. Date established for contract definitization: November 1, 1993.
- 10/20/92 Deputy USD(A) wrote memorandum, subject: "V-22 Derivative Demonstration Program," to ASN(RD&A) stating, "I have chosen not to review the V-22 contract. It may be awarded upon completion of the Navy review."
- 10/22/92 FSD airframe contract was terminated. Letter contract awarded to Bell-Boeing to begin EMD. Type: Cost-reimbursable. Price: \$550 million.
- 10/29/92 Acting Program executive officer approved Acquisition Plan, Revision 1.

Appendix B. Chronology of Events for V-22 Program

- 12/10/92 Deputy ASN(RD&A) for Acquisition Policy, Integrity, and Accountability memorandum requested Director, Acquisition Policy and Program Integration, USD(A), waive review of request for proposal and contract for engine letter contract to meet aircraft "derivative demonstration program" schedule.
- 12/15/92 Director, Acquisition Policy and Program Integration, USD(A), granted waiver for review of engine request for proposal and contract for "derivative demonstration program."
- 12/18/92 Navy placed synopsis in *Commerce Business Daily* of contract award to Bell-Boeing on October 22, 1992, to "modify and test the V-22 derivative aircraft." The contract amount is \$1.4 billion, of which \$550 million is being obligated.
- 12/29/92 EMD engine letter contract awarded to Allison. Price: \$65 million.
- 1/25/93 Program executive officer commented in Defense Acquisition Executive Summary, "Recommend that a DAB level program review be held in the near term to review all aspects of the EMD program plan."
- 2/24/93 Program executive officer memorandum to ASN(RD&A) requested DAB formally document approval to enter EMD.
- 4/15/93 Bell-Boeing submitted initial proposal for V-22 EMD. Price: \$2.35 billion.
- 6/1/93 Program executive officer memorandum to ASN(RD&A) stated that the baseline V-22 Program is currently unexecutable in both EMD and production due to budgetary shortfalls.
- 6/10/93 JROC validated MV-X mission-need statement, establishing the requirement for a deep infiltration, exfiltration capability. The JROC stated that, in light of a rapidly changing strategic environment, the JSOR is valid only as a statement of the broad, generic mission need for an MLR aircraft (CH-46E follow-on).
- 6/17/93 CSC program review. Objectives were to better understand status of EMD program, linkage between MLR requirements and V-22 Program trade-off studies, joint program potential, and dual-use potential of V-22 (civil and military). Assistant Secretary of Defense (Program Analysis and Evaluation) was requested to develop cost and operational effectiveness analysis guidance. Navy was tasked to develop costed V-22 and helicopter alternatives.
- 6/30/93 USD(A) program review. Purpose was to review requirements status, including JSOR, MLR, and MV-X; review status of V-22 Program; evaluate alternative programs to satisfy MLR and MV-X requirements; and determine potential guidance for formal approval of V-22 EMD

Appendix B. Chronology of Events for V-22 Program

- program, establishment of V-22 development goals, Milestone 0 approval to MV-X, and integration of MLR and MV-X cost and operational effectiveness analyses.
- 8/5/93 USD(A) memorandum provided V-22, MLR, and MV-X guidance. It directed an integrated MLR and MV-X cost and operational effectiveness analysis, a schedule leading to DAB consideration of MV-X Milestone 0 approval, Navy preparation of program profiles to match three illustrative future years Defense program approximate funding levels, Navy and Special Operations Command preparation for November DAB that would consider V-22 as candidate for Milestone II-Plus decision, and preparation of documentation for DAB. It also requested that JROC review Navy and Special Operations Command-proposed ORDs and recommend whether a single or joint requirement should be adopted.
- 9/30/93 EMD engine letter contract was definitized. Target price: \$140.9 million. Type: cost-plus incentive fee.
- 9/30/93 Bell-Boeing submitted "Delta" proposal for V-22 EMD. Price: \$2.55 billion.
- 12/6/93 JROC validated key performance parameters for MV-X but not for MLR, citing concerns with speed and self-deployability.
- 12/7/93 CSC meeting held to prepare for DAB Milestone II-Plus review scheduled for December 9, 1993.
- 12/8/93 DAB readiness meeting held to prepare for DAB Milestone II-Plus review scheduled for December 9, 1993. Navy requested that DAB review be delayed until certain issues can be resolved.
- 12/10/93 Bell-Boeing submitted "Delta Update" proposal for V-22 EMD. Price: \$2.639 billion.
- 12/13/93 ASN(RD&A) requested that USD(A&T) reschedule DAB review no later than September 1994 and before the FY 1996 budget review.
- 12/15/93 USD(A&T) cited need for V-22 or any other Marine Corps medium-lift alternative to have firm analytical support before commitment to production. He approved all actions proposed in ASN(RD&A) memorandum, December 13, 1993; rescheduled DAB review for September 9, 1994; and directed redesignation of V-22 procurement funds in Navy Program Objective Memorandum as "Marine Corps Medium Lift Alternative," pending a decision on how to meet the requirement.
- 4/20/94 ASN(RD&A) requested that USD(A&T) concur with Navy plan to definitize EMD contract. Also, ASN(RD&A) notified Vice Chairman of Joint Chiefs of Staff of Navy plan to definitize EMD contract and asked to discuss any concerns the Vice Chairman had with that plan.

Appendix B. Chronology of Events for V-22 Program

- 4/29/94 USD(A&T) authorized ASN(RD&A) to definitize EMD contract.
- 5/3/94 Navy definitized EMD contract. Type: Cost-plus-award-fee. Estimated cost plus award fee: \$2.65 billion (\$2,390 million plus \$260 million).
- 5/23/94 The Vice Chairman, Joint Chiefs of Staff, concurred with definitization of EMD contract but noted that such concurrence should not be construed as concurrence with specific values of requirements expressed in the JSOR, the definitized EMD contract, or the Marine Corps draft ORD. The Vice Chairman added that those decisions would be made in the upcoming JROC meeting on medium-lift issues.

Appendix C. Organizations Visited or Contacted

Office of the Secretary of Defense

Under Secretary of Defense for Acquisition and Technology, Washington, DC
Director, Acquisition Program Integration, Washington, DC
Director, Defense Procurement, Washington, DC
Director, Operational Test and Evaluation, Washington, DC
Director, Program Analysis and Evaluation, Washington, DC
Director, Tactical Systems, Washington, DC
Director, Test and Evaluation, Washington, DC
Comptroller of the Department of Defense, Washington, DC
Deputy Comptroller, Management Systems, Washington, DC
Deputy Comptroller, Program and Budget, Washington, DC

Department of the Navy

Assistant Secretary of the Navy (Financial Management), Washington, DC
Assistant Secretary of the Navy (Research, Development, and Acquisition),
Washington, DC
Deputy Assistant Secretary of the Navy (Air Warfare), Washington, DC
Program Executive Officer, Air Anti-Submarine Warfare, Assault and Special
Mission Programs, Arlington, VA
Medium-Lift Replacement Program Office, Arlington, VA
V-22 Program Office, Arlington, VA
Chief of Naval Research, Arlington, VA
Naval Air Systems Command, Arlington, VA
Counsel, Office of Comptroller of the Navy, Washington, DC

Other Defense Organizations

Defense Logistics Agency, Defense Contract Management Command, Defense Plant
Representative Office, Boeing Helicopters, Philadelphia, PA
Joint Staff, Washington, DC

Contractor

Boeing, Philadelphia, PA

Appendix D. Report Distribution

Office of the Secretary of Defense

Under Secretary of Defense for Acquisition and Technology
Deputy Under Secretary of Defense for Acquisition Reform
Director, Acquisition Program Integration
Director, Defense Procurement
Director, Defense Research and Engineering
Director, Operational Test and Evaluation
Director, Program Analysis and Evaluation
Director, Tactical Systems
Director, Test and Evaluation
Assistant Secretary of Defense (Legislative Affairs)
Comptroller of the Department of Defense
Deputy Comptroller, Management Systems
Deputy Comptroller, Program and Budget
General Counsel
Assistant to the Secretary of Defense (Public Affairs)

Department of the Navy

Secretary of the Navy
Commandant of the Marine Corps
Assistant Secretary of the Navy (Financial Management)
Assistant Secretary of the Navy (Research, Development, and Acquisition)
Commander, Naval Air Systems Command
Comptroller of the Navy
Auditor General, Naval Audit Service
Deputy Assistant Secretary of the Navy (Air Warfare)
Chief of Naval Research
Program Executive Officer, Air Anti-Submarine Warfare, Assault and Special Mission Programs
Program Manager, Medium-Lift Replacement Program Office
Program Manager, V-22 Program Office

Department of the Air Force

Air Force Audit Agency

Other Defense Organizations

Chairman, Joint Chiefs of Staff

Commander in Chief, U.S. Special Operations Command
Inspector General, Central Imagery Office
Director, Defense Contract Audit Agency
Director, Defense Logistics Agency
Inspector General, Defense Intelligence Agency
Inspector General, National Security Agency
Director, Defense Logistics Studies Information Exchange
Defense Contract Management Command
Commander, Defense Plant Representative Office, Boeing Helicopters

Non-Defense Organizations

Office of Management and Budget
U.S. General Accounting Office, National Security and International Affairs Division,
Technical Information Center

Chairman and Ranking Minority Member of the Following Congressional Committees
and Subcommittees:

Senate Committee on Appropriations
Senate Subcommittee on Defense, Committee on Appropriations
Senate Committee on Armed Services
Senate Committee on Governmental Affairs
House Committee on Appropriations
House Subcommittee on Defense, Committee on Appropriations
House Committee on Armed Services
House Committee on Government Operations
House Subcommittee on Legislation and National Security, Committee on
Government Operations

Part IV - Management Comments

Assistant Secretary of the Navy (Research, Development, and Acquisition) Comments



THE ASSISTANT SECRETARY OF THE NAVY
(Research, Development and Acquisition)
WASHINGTON, D.C. 20350-1000

02 MAY 1994

MEMORANDUM FOR THE INSPECTOR GENERAL, DEPARTMENT OF DEFENSE

Subj: REVIEW OF THE V-22 AIRCRAFT PROGRAM (PROJECT NO.
3AE-0063.01)

Ref: (a) DOD IG Memo of 18 March 1994

Encl: (1) Key Performance Chart

In the reference (a) draft report, you recommended that I postpone definitization of the V-22 Engineering and Manufacturing Development contract and limit obligation of contract funding to no more than the FY 1993 and prior appropriations until the Defense Acquisition Board Milestone II-Plus review is held and the Defense Acquisition Executive issues an acquisition decision memorandum choosing the V-22 as the alternative to meet validated requirements.

Definitizing the contract will not increase the Government's financial commitment as compared to continuing work under the letter contract. Until the contract is definitized, the contractor will continue working toward a proposed price higher than the negotiated price and the incentive to control cost will be diminished. As long as the contract remains undefinitized, there will not be an established baseline against which to measure performance under the contract. Therefore, it would not make good business sense to delay definitization or limit obligation of appropriated funding on the contract. Government liability will be limited by a negotiated termination liability schedule consistent with the budgeted funding levels.

As we discussed in our recent meeting, here are my plans:

1. I plan to definitize the contract, because we need to establish a baseline which to measure contractor performance against and to better control contract cost.
2. We will definitize the contract to the performance parameters listed on the enclosure under "EMD CONTRACT". The resulting aircraft are intended to meet the USMC draft requirements and be fully provisioned to meet USSOCOM requirements.
3. Upon DAB approval this fall, we will make any changes required to the EMD contract via contract modifications.

The Acting Under Secretary of Defense (Acquisition and Technology) concurs in my approach.

A handwritten signature in cursive script, appearing to read "Nora Slatkin".

Nora Slatkin



KEY PERFORMANCE PARAMETERS AND EMD CONTRACT COMPARISON



<u>PARAMETER</u>	<u>MLR ORD USMC 93</u>	<u>MVX SOCOM</u>	<u>EMD CONTRACT</u>
CRUISE SPEED (KTS)	<u>250(T) / 275(O)</u>	<u>230(T) / 250(O)</u>	275
MISSION RADIUS (NM)	<u>200(T)</u>	<u>500(T) / 750 (O)</u>	200 / 500*
TROOP SEATS	<u>24(T)</u>	<u>18(T) / 24(O)</u>	24
SELF DEPLOY (NM)	<u>2100 / 1 AERIAL REFUEL</u>	<u>2100 / 1 AERIAL REFUEL</u>	2100 / 1 AERIAL REFUEL*
AIR-AIR REFUEL	<u>YES</u>	<u>YES</u>	YES
NIGHT - ALL WEATHER	YES	<u>YES</u>	YES
V/STOL - SHIP COMPATIBLE	<u>YES</u>	<u>YES</u>	YES
EXTERNAL LOADS (LBS)	<u>10K(T) / 15K(O)</u>	10K (SINGLE) / 15K (DOUBLE)	10K (SINGLE) / 15K (DOUBLE)
SURVIVABILITY	<u>YES</u>	YES	YES
WEAPON SYSTEM REL (%)	N/A	<u>77(T) / 84(O)</u>	79*
PRECISION NAV	GPS	<u>INS / GPS</u>	GPS / LWINS
TERRAIN FOL / TERRAIN AVOID (FT)	N/A	<u>300(T) / 100(O)</u>	YES*

KEY PERFORMANCE PARAMETERS

* FY96 START
(T)= Threshold/ (O)= Objective

MAR4975R1

45

Audit Team Members

**Donald E. Reed
Russell A. Rau
Brian M. Flynn
Dennis E. Coldren
Haskell I. Lynn
Mary Ann Hourclé
Tammy L. O'Deay**